

CMOS Analog Multiplexers

The DG506A, DG507A, DG508A and DG509A are CMOS Monolithic 16-Channel/Dual 8-Channel and 8-Channel/Dual 4-Channel Analog Multiplexers, which can also be used as demultiplexers. An enable input is provided. When the enable input is high, a channel is selected by the address inputs, and when low, all channels are off.

A channel in the ON state conducts current equally well in both directions. In the OFF state each channel blocks voltages up to the supply rails. The address inputs and the enable input are TTL and CMOS compatible over the full specified operating temperature range.

The DG506A, DG507A, DG508A and DG509A are pinout compatible with the industry standard devices.

Features

- Low Power Consumption
- TTL and CMOS-Compatible Address and Enable Inputs
- 44V Maximum Power Supply Rating
- High Latch-Up Immunity
- Break-Before-Make Switching
- Alternate Source

Applications

- Data Acquisition Systems
- Communication Systems
- Signal Multiplexing/Demultiplexing
- Audio Signal Multiplexing

Ordering Information

PART NUMBER	TEMP. RANGE (°C)	PACKAGE	PKG. NO.
DG506AAK	-55 to 125	28 Ld CERDIP	F28.6
DG506ACJ	0 to 70	28 Ld PDIP	E28.6
DG506ACY	0 to 70	28 Ld SOIC	M28.3
DG507ABK	-25 to 85	28 Ld CERDIP	F28.6
DG507ACJ	0 to 70	28 Ld PDIP	E28.6
DG507ACY	0 to 70	28 Ld SOIC	M28.3

PART NUMBER	TEMP. RANGE (°C)	PACKAGE	PKG. NO.
DG508AAK	-55 to 125	16 Ld CERDIP	F16.3
DG508ABK	-25 to 85	16 Ld CERDIP	F16.3
DG508ACJ	0 to 70	16 Ld PDIP	E16.3
DG509ACJ	0 to 70	16 Ld PDIP	E16.3
DG509ACY	0 to 70	16 Ld SOIC	M16.3

Pinouts

DG506A (PDIP, CERDIP, SOIC)
TOP VIEW

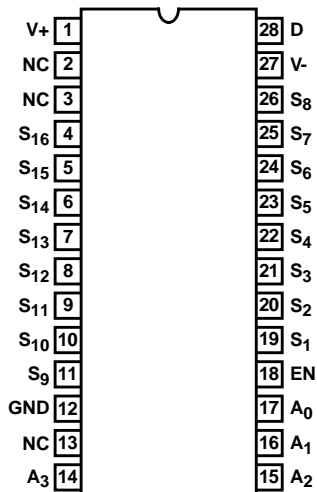

DG507A (PDIP, CERDIP, SOIC)
TOP VIEW

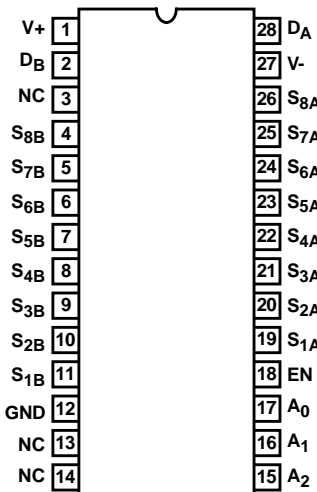

DG508A (PDIP, CERDIP)
TOP VIEW

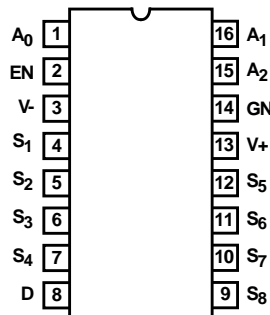

DG509A (PDIP, SOIC)
TOP VIEW

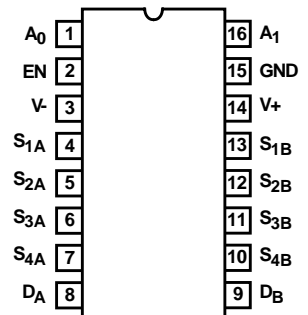

Truth Tables

DG506A

A ₃	A ₂	A ₁	A ₀	EN	ON SWITCH
X	X	X	X	0	None
0	0	0	0	1	1
0	0	0	1	1	2
0	0	1	0	1	3
0	0	1	1	1	4
0	1	0	0	1	5
0	1	0	1	1	6
0	1	1	0	1	7
0	1	1	1	1	8
1	0	0	0	1	9
1	0	0	1	1	10
1	0	1	0	1	11
1	0	1	1	1	12
1	1	0	0	1	13
1	1	0	1	1	14
1	1	1	0	1	15
1	1	1	1	1	16

Logic "0" = V_{AL}, V_{ENL} ≤ 0.8V, Logic "1" = V_{AH}, V_{ENH} ≥ 2.4V.

DG507A

A ₂	A ₁	A ₀	EN	ON SWITCH
X	X	X	0	None
0	0	0	1	1
0	0	1	1	2
0	1	0	1	3
0	1	1	1	4
1	0	0	1	5
1	0	1	1	6
1	1	0	1	7
1	1	1	1	8

Logic "0" = V_{AL}, V_{ENL} ≤ 0.8V, Logic "1" = V_{AH}, V_{ENH} ≥ 2.4V.

DG509A

A ₁	A ₀	EN	ON SWITCH
X	X	0	None
0	0	1	1A, 1B
0	1	1	2A, 2B
1	0	1	3A, 3B
1	1	1	4A, 4B

A₀, A₁, EN
Logic "1" = V_{AH} ≥ 2.4V, Logic "0" = V_{AL} ≤ 0.8V.

DG508A

A ₂	A ₁	A ₀	EN	ON SWITCH
X	X	X	0	None
0	0	0	1	1
0	0	1	1	2
0	1	0	1	3
0	1	1	1	4
1	0	0	1	5
1	0	1	1	6
1	1	0	1	7
1	1	1	1	8

A₀, A₁, A₂, EN
Logic "1" = V_{AH} ≥ 2.4V, Logic "0" = V_{AL} ≤ 0.8V

Functional Diagrams

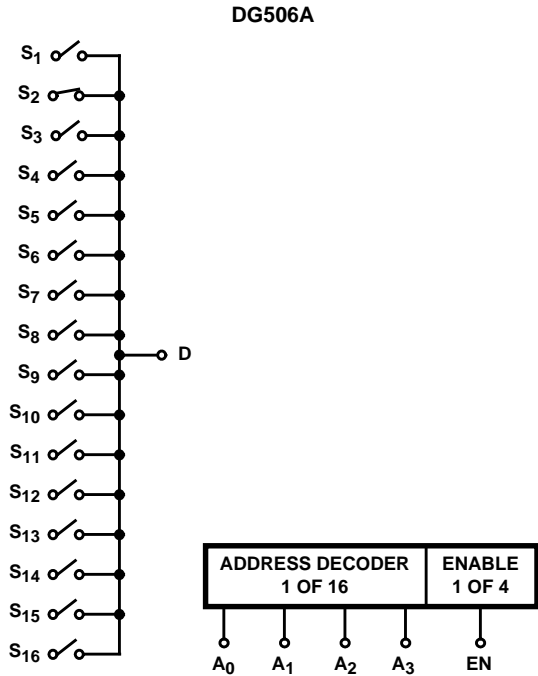

4 Line Binary Address Inputs
(0 0 0 1) and EN = 5V
Above example shows channel 2 turned ON.

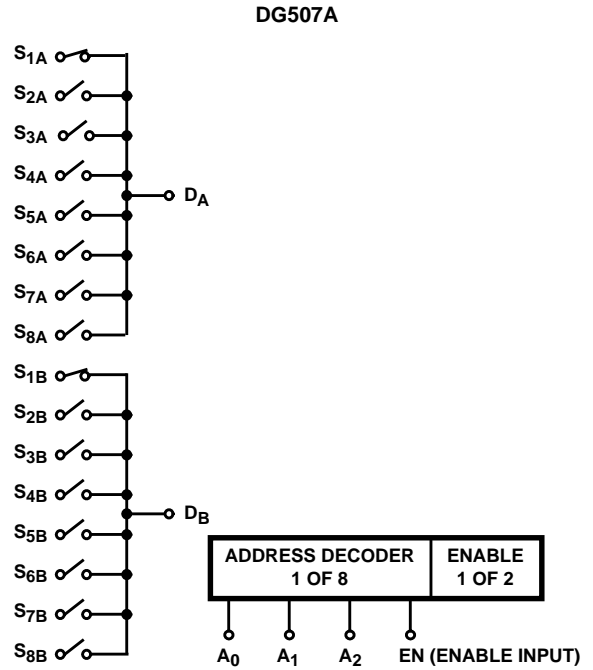

3 Line Binary Address Inputs
(0 0 0) and EN = 5V
Above example shows channels 1_A and 1_B turned ON.

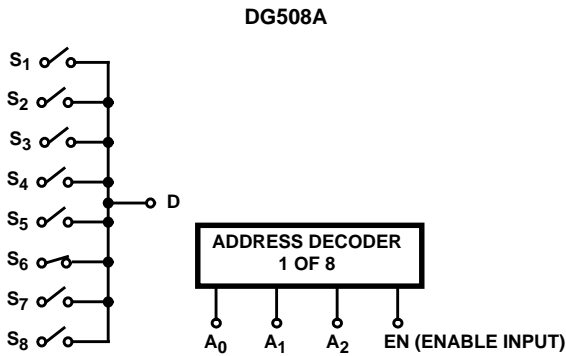

3 Line Binary Address Inputs
(1 0 1) and EN = 1
Above example shows channel 6 turned ON.

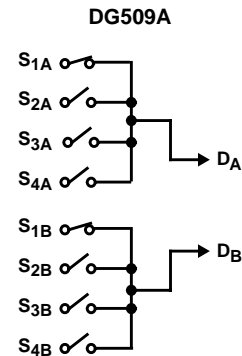

2 Line Binary Address Inputs
(0 0) and EN = 1
Above example shows channels 1_A and 1_B turned ON.

Schematic Diagram

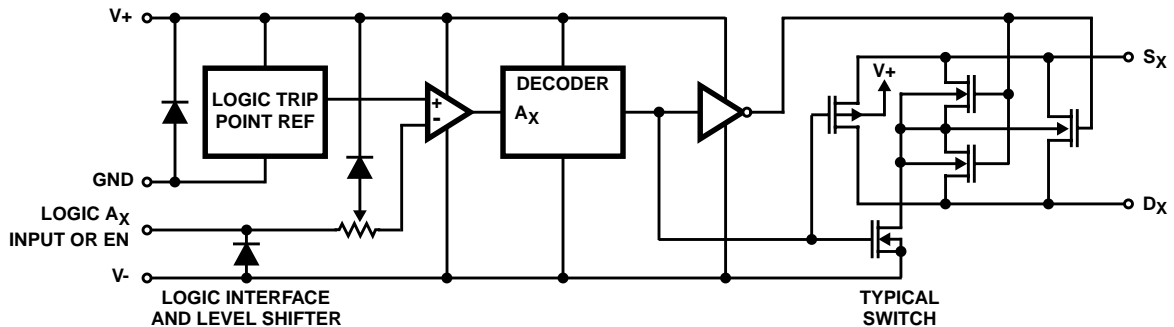

DG506A, DG507A, DG508A, DG509A

Absolute Maximum Ratings

V+ to V-	44V
V- to Ground	25V
Digital Inputs, V _S , V _D (Note 1)	(V- -2V) To (V+ +2V)
Continuous Current, (Any Terminal Except S or D)	30mA
Continuous Current, (S or D)	20mA
Peak Current, S or D (Pulsed 1ms, 10% Duty Cycle Max)	40mA

Operating Conditions

Temperature Range	
"A" Suffix	-55°C to 125°C
"B" Suffix	-25°C to 85°C
"C" Suffix	0°C to 70°C

Thermal Information

Thermal Resistance (Typical, Note 2)	θ_{JA} (°C/W)	θ_{JC} (°C/W)
16 Ld CERDIP Package	75	20
28 Ld CERDIP Package	55	18
16 Ld PDIP Package	90	N/A
28 Ld PDIP Package	55	N/A
16 Ld SOIC Package	100	N/A
28 Ld SOIC Package	70	N/A
Maximum Junction Temperature		
CERDIP Package	175°C	
PDIP Package	150°C	
Maximum Storage Temperature		
"A" and "B" Suffix	-65°C to 150°C	
"C" Suffix	-65°C to 125°C	
Maximum Lead Temperature (Soldering 10s)	300°C	
(SOIC - Lead Tips Only)		

CAUTION: Stresses above those listed in "Absolute Maximum Ratings" may cause permanent damage to the device. This is a stress only rating and operation of the device at these or any other conditions above those indicated in the operational sections of this specification is not implied.

NOTES:

1. Signals on S_X, D_X, E_N, or A_X exceeding V+ or V- are clamped by internal diodes. Limit diode current to maximum current ratings.
2. θ_{JA} is measured with the component mounted on an evaluation PC board in free air.

Electrical Specifications $T_A = 25^\circ\text{C}$, V+ = +15V, V- = -15V, GND = 0V, V_{EN} = 2.4V, Unless Otherwise Specified

PARAMETER	TEST CONDITIONS	"A" SUFFIX			"B" AND "C" SUFFIX			UNITS
		(NOTE 4) MIN	(NOTE 3) TYP	(NOTE 4) MAX	(NOTE 4) MIN	(NOTE 3) TYP	(NOTE 4) MAX	
DYNAMIC CHARACTERISTICS								
Switching Time of Multiplexer, t _{TRANSITION}	See Figure 1	-	0.6	1	-	0.6	-	μs
Break-Before-Make Interval, t _{OPEN}	See Figure 3	-	0.2	-	-	0.2	-	μs
Enable Turn-ON Time, t _{ON(EN)}	See Figure 2	-	1	1.5	-	1	-	μs
Enable Turn-OFF Time, t _{OFF(EN)}	See Figure 2	-	0.4	1.0	-	0.4	-	μs
OFF Isolation, OIRR	V _{EN} = 0V, R _L = 1kΩ, C _L = 15pF, V _S = 7V _{RMS} , f = 500kHz (Note 5)	-	68	-	-	68	-	dB
Source OFF Capacitance, C _{S(OFF)}	V _S = 0V, V _{EN} = 0V, f = 140kHz							
DG506A, DG507A		-	6	-	-	6	-	pF
DG508A, DG509A		-	5	-	-	5	-	pF
Drain OFF Capacitance, C _{D(OFF)}	V _D = 0V, V _{EN} = 0V, f = 140kHz							
DG506A		-	45	-	-	45	-	pF
DG507A		-	23	-	-	23	-	pF
DG508A		-	25	-	-	25	-	pF
DG509A		-	12	-	-	12	-	pF
Charge Injection, Q	See Figure 4							
DG506A, DG507A		-	6	-	-	6	-	pC
DG508A, DG509A		-	4	-	-	4	-	pC
DIGITAL INPUT CHARACTERISTICS								
Address Input Current, Input Voltage High, I _{AH}	V _A = 2.4V	-10	-0.002	-	-10	-0.002	-	μA
	V _A = 15V	-	0.006	10	-	0.006	10	μA
Address Input Current Input Voltage Low, I _{AL}	V _{EN} = 2.4V	-10	-0.002	-	-10	-0.002	-	μA
	V _{EN} = 0V							

DG506A, DG507A, DG508A, DG509A

Electrical Specifications $T_A = 25^{\circ}\text{C}$, $V_+ = +15\text{V}$, $V_- = -15\text{V}$, $\text{GND} = 0\text{V}$, $V_{\text{EN}} = 2.4\text{V}$, Unless Otherwise Specified **(Continued)**

PARAMETER	TEST CONDITIONS	"A" SUFFIX			"B" AND "C" SUFFIX			UNITS	
		(NOTE 4) MIN	(NOTE 3) TYP	(NOTE 4) MAX	(NOTE 4) MIN	(NOTE 3) TYP	(NOTE 4) MAX		
ANALOG SWITCH CHARACTERISTICS									
Analog Signal Range, V_{ANALOG}	(Note 7)	-15	-	+15	-15	-	+15	V	
Drain-Source ON Resistance, $r_{\text{DS(ON)}}$	Sequence Each Switch ON $V_{\text{AL}} = 0.8\text{V}$ $V_{\text{AH}} = 2.4\text{V}$	$I_{\text{S}} = -200\mu\text{A}$, $V_{\text{D}} = +10\text{V}$	-	270	400	-	270	450	Ω
		$I_{\text{S}} = -200\mu\text{A}$, $V_{\text{D}} = -10\text{V}$	-	230	400	-	230	450	Ω
$r_{\text{DS(ON)}}$ Matching Between Channels	$-10\text{V} \leq V_{\text{S}} \leq +10\text{V}$ $\Delta r_{\text{DS(ON)}} = \frac{r_{\text{DS(ON)MAX}} - r_{\text{DS(ON)MIN}}}{r_{\text{DS(ON)AVG}}}$	-	6	-	-	6	-	%	
Source OFF Leakage Current, $I_{\text{S(OFF)}}$	$V_{\text{EN}} = 0\text{V}$	$V_{\text{S}} = +10\text{V}$, $V_{\text{D}} = -10\text{V}$	-1	0.002	1	-5	0.002	5	nA
		$V_{\text{S}} = -10\text{V}$, $V_{\text{D}} = +10\text{V}$	-1	-0.005	1	-5	-0.005	5	nA
Drain OFF Leakage Current, $I_{\text{D(OFF)}}$ DG506A DG507A DG508A DG509A	$V_{\text{EN}} = 0\text{V}$	$V_{\text{S}} = -10\text{V}$, $V_{\text{D}} = +10\text{V}$	-10	0.02	10	-20	0.02	20	nA
		$V_{\text{S}} = +10\text{V}$, $V_{\text{D}} = -10\text{V}$	-10	-0.03	10	-20	-0.03	20	nA
		$V_{\text{S}} = -10\text{V}$, $V_{\text{D}} = +10\text{V}$	-5	0.007	5	-10	0.007	10	nA
		$V_{\text{S}} = +10\text{V}$, $V_{\text{D}} = -10\text{V}$	-5	-0.015	5	-10	-0.015	10	nA
		$V_{\text{S}} = -10\text{V}$, $V_{\text{D}} = +10\text{V}$	-	0.01	10	-	0.01	20	nA
		$V_{\text{S}} = +10\text{V}$, $V_{\text{D}} = -10\text{V}$	-10	-0.015	-	-20	-0.015	-	nA
		$V_{\text{S}} = -10\text{V}$, $V_{\text{D}} = +10\text{V}$	-	0.005	10	-	0.005	20	nA
		$V_{\text{S}} = +10\text{V}$, $V_{\text{D}} = -10\text{V}$	-10	-0.008	-	-20	-0.008	-	nA
Drain ON Leakage Current, $I_{\text{D(ON)}}$ DG506A DG507A DG508A DG509A	(Note 6) Sequence Each Switch ON $V_{\text{AL}} = 0.8\text{V}$ $V_{\text{AH}} = 2.4\text{V}$	$V_{\text{D}} = V_{\text{S(ALL)}} = +10\text{V}$	-10	0.03	10	-20	0.03	20	nA
		$V_{\text{D}} = V_{\text{S(ALL)}} = -10\text{V}$	-10	-0.06	10	-20	-0.06	20	nA
		$V_{\text{D}} = V_{\text{S(ALL)}} = +10\text{V}$	-5	0.015	5	-10	0.015	10	nA
		$V_{\text{D}} = V_{\text{S(ALL)}} = -10\text{V}$	-5	-0.03	5	-10	-0.03	10	nA
		$V_{\text{D}} = V_{\text{S(ALL)}} = +10\text{V}$	-	0.015	10	-	0.015	20	nA
		$V_{\text{D}} = V_{\text{S(ALL)}} = -10\text{V}$	-10	-0.03	-	-20	-0.03	-	nA
		$V_{\text{D}} = V_{\text{S(ALL)}} = +10\text{V}$	-	0.007	10	-	0.007	20	nA
		$V_{\text{D}} = V_{\text{S(ALL)}} = -10\text{V}$	-10	-0.015	-	-20	-0.015	-	nA
POWER SUPPLY CHARACTERISTICS									
Positive Supply Current, I_+	$V_{\text{EN}} = 5.0\text{V}$, $V_{\text{A}} = 0\text{V}$ (Enabled)	-	1.3	2.4	-	1.3	2.4	mA	
Negative Supply Current, I_-		-1.5	-0.7	-	-1.5	-0.7	-	mA	
Positive Supply Current, I_+ Standby	$V_{\text{EN}} = 0\text{V}$, $V_{\text{A}} = 0\text{V}$ (Standby)	-	1.3	2.4	-	1.3	2.4	mA	
Negative Supply Current, I_- Standby		-1.5	-0.7	-	-1.5	-0.7	-	mA	

DG506A, DG507A, DG508A, DG509A

Electrical Specifications T_A = Over Operating Temperature Range, $V_+ = +15V$, $V_- = -15V$, $GND = 0V$, $V_{EN} = 2.4V$, Unless Otherwise Specified

PARAMETER	TEST CONDITIONS	"A" SUFFIX			"B" AND "C" SUFFIX			UNITS
		MIN	(NOTE 3) TYP	MAX	MIN	(NOTE 3) TYP	MAX	
DIGITAL INPUT CHARACTERISTICS								
Address Input Current, Input Voltage High, I_{AH}	$V_A = 2.4V$	-30	-	-	-	-	-	μA
	$V_A = 15V$	-	-	30	-	-	-	μA
Address Input Current Input Voltage Low, I_{AL}	$V_{EN} = 2.4V$	$V_A = 0V$	-30	-	-	-	-	μA
	$V_{EN} = 0V$		-30	-	-	-	-	μA
ANALOG SWITCH CHARACTERISTICS								
Analog Signal Range, V_{ANALOG}	(Note 7)	-15	-	+15	-	-	-	V
Drain-Source ON Resistance, $r_{DS(ON)}$	Sequence Each Switch ON $V_{AL} = 0.8V$ $V_{AH} = 2.4V$	$I_S = -200\mu A$, $V_D = +10V$	-	-	500	-	-	Ω
		$I_S = -200\mu A$, $V_D = -10V$	-	-	500	-	-	Ω
Source OFF Leakage Current, $I_{S(OFF)}$	$V_{EN} = 0V$	$V_S = +10V$, $V_D = -10V$	-	-	50	-	-	nA
		$V_S = -10V$, $V_D = +10V$	-50	-	-	-	-	nA
Drain OFF Leakage Current, $I_{D(OFF)}$ DG506A DG507A DG508A DG509A	$V_{EN} = 0V$	$V_S = -10V$, $V_D = +10V$	-	-	300	-	-	nA
		$V_S = +10V$, $V_D = -10V$	-300	-	-	-	-	nA
		$V_S = -10V$, $V_D = +10V$	-	-	200	-	-	nA
		$V_S = +10V$, $V_D = -10V$	-200	-	-	-	-	nA
		$V_S = -10V$, $V_D = +10V$	-	-	200	-	-	nA
		$V_S = +10V$, $V_D = -10V$	-200	-	-	-	-	nA
		$V_S = -10V$, $V_D = +10V$	-	-	100	-	-	nA
		$V_S = +10V$, $V_D = -10V$	-100	-	-	-	-	nA
Drain ON Leakage Current, $I_{D(ON)}$ DG506A DG507A DG508A DG509A	(Note 6) Sequence Each Switch ON $V_{AL} = 0.8V$ $V_{AH} = 2.4V$	$V_D = V_{S(ALL)} = +10V$	-	-	300	-	-	nA
		$V_D = V_{S(ALL)} = -10V$	-300	-	-	-	-	nA
		$V_D = V_{S(ALL)} = +10V$	-	-	200	-	-	nA
		$V_D = V_{S(ALL)} = -10V$	-200	-	-	-	-	nA
		$V_D = V_{S(ALL)} = +10V$	-	-	200	-	-	nA
		$V_D = V_{S(ALL)} = -10V$	-200	-	-	-	-	nA
		$V_D = V_{S(ALL)} = +10V$	-	-	100	-	-	nA
		$V_D = V_{S(ALL)} = -10V$	-100	-	-	-	-	nA
POWER SUPPLY CHARACTERISTICS								
Positive Supply Current, I_+	$V_{EN} = 5.0V$, $V_A = 0V$	-3.2	-	4.5	-	-	-	mA
Negative Supply Current, I_-		-3.2	-	4.5	-	-	-	mA
Positive Standby Supply Current, I_+	$V_{EN} = 0V$, $V_A = 0V$	-3.2	-	4.5	-	-	-	mA
Negative Standby Supply Current, I_-		-3.2	-	4.5	-	-	-	mA

NOTES:

3. Typical values are for design aid only, not guaranteed and not subject to production testing.
4. The algebraic convention whereby the most negative value is a minimum, and the most positive value is a maximum, is used in this data sheet.
5. Off isolation = $20\log |V_S|/|V_D|$, where V_S = input to Off switch, and V_D = output due to V_S .
6. $I_{D(ON)}$ is leakage from driver into "ON" switch.
7. Parameter not tested. Parameter guaranteed by design or characterization.

Test Circuits and Waveforms

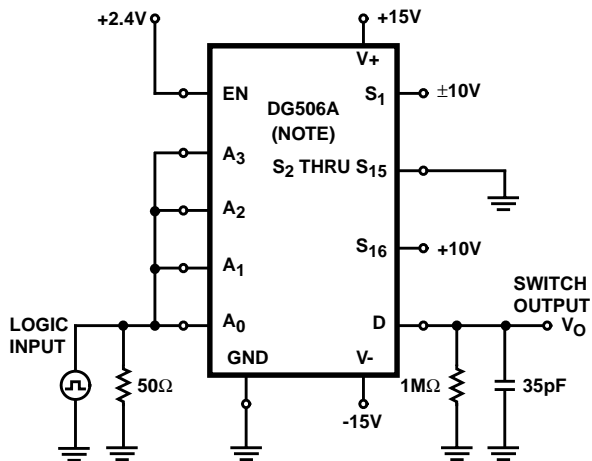

NOTE: Similar connections for DG508A.

FIGURE 1A. DG506A TEST CIRCUIT

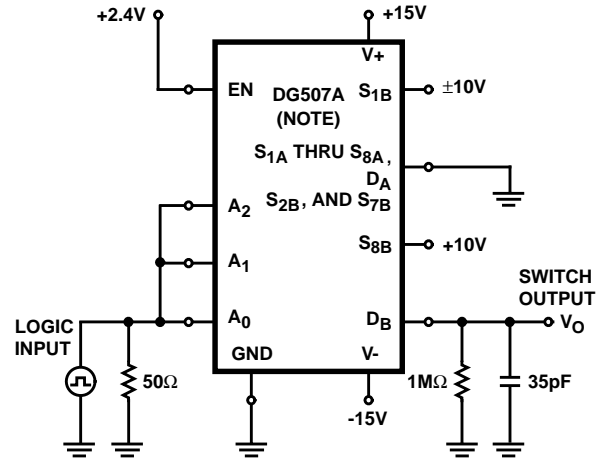

NOTE: Similar connections for DG509A.

FIGURE 1B. DG507A TEST CIRCUIT

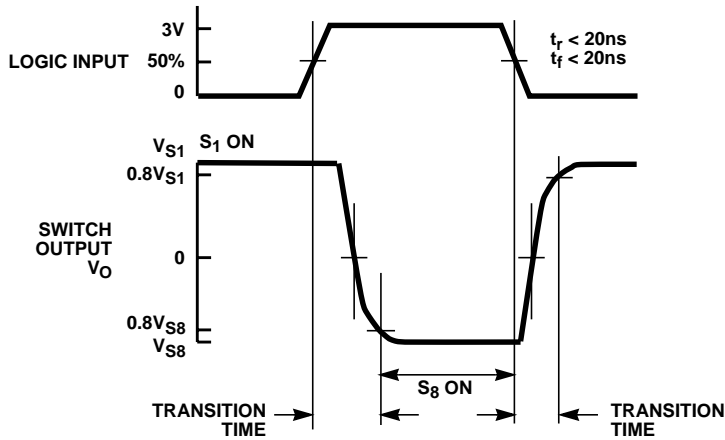
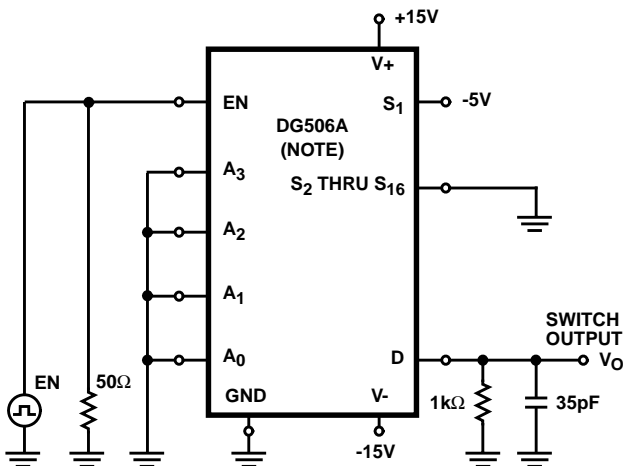
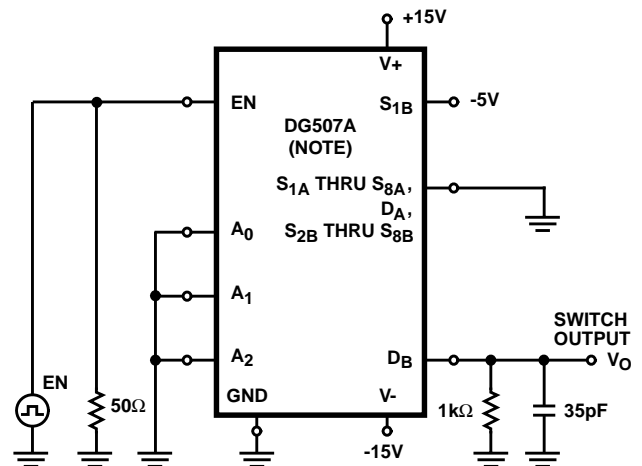

FIGURE 1C. MEASUREMENT POINTS
FIGURE 1. SWITCHING TIME



NOTE: Similar connections for DG508A.

FIGURE 2A. DG506A TEST CIRCUIT



NOTE: Similar connections for DG509A.

FIGURE 2B. DG507A TEST CIRCUIT

Test Circuits and Waveforms (Continued)

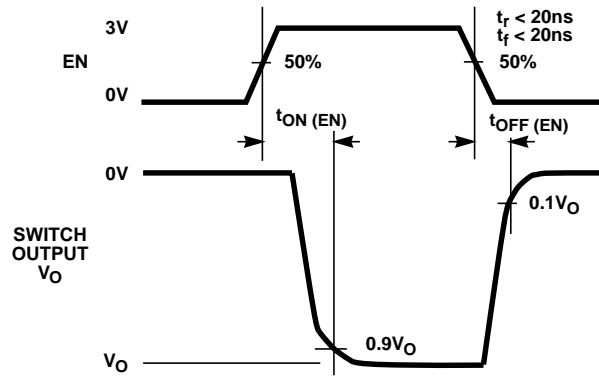
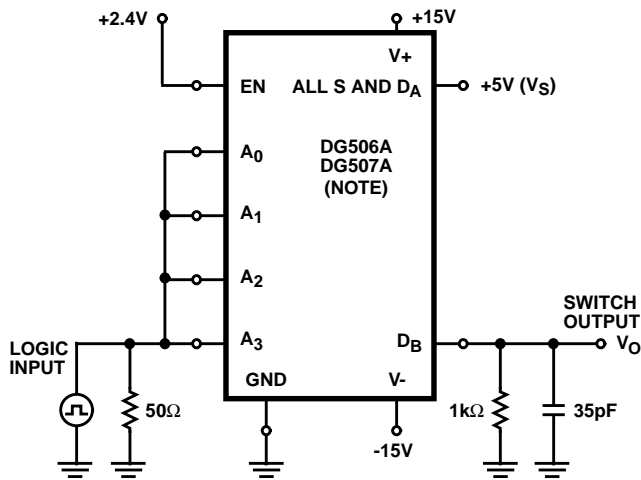

FIGURE 2C. MEASUREMENT POINTS
FIGURE 2. ENABLE TIMES



NOTE: Similar connections for DG508A, DG509A.

FIGURE 3A. TEST CIRCUIT

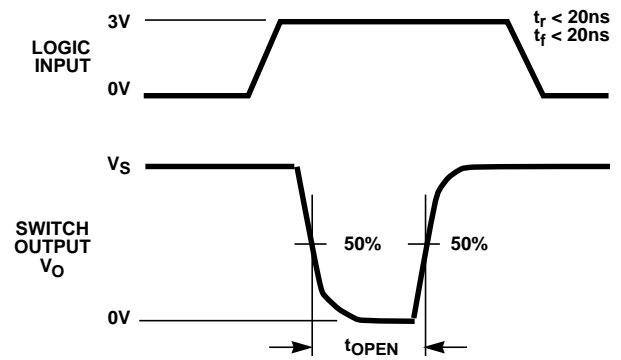
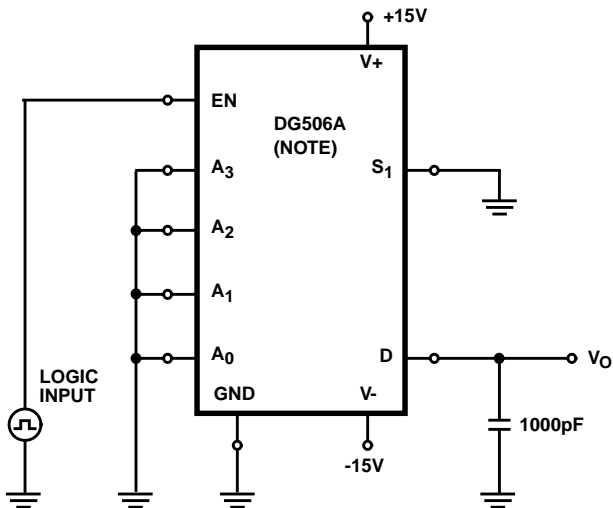

FIGURE 3B. MEASUREMENT POINTS

FIGURE 3. BREAK-BEFORE-MAKE INTERVAL



NOTE: Similar connections for DG508A.

FIGURE 4A. DG506A TEST CIRCUIT

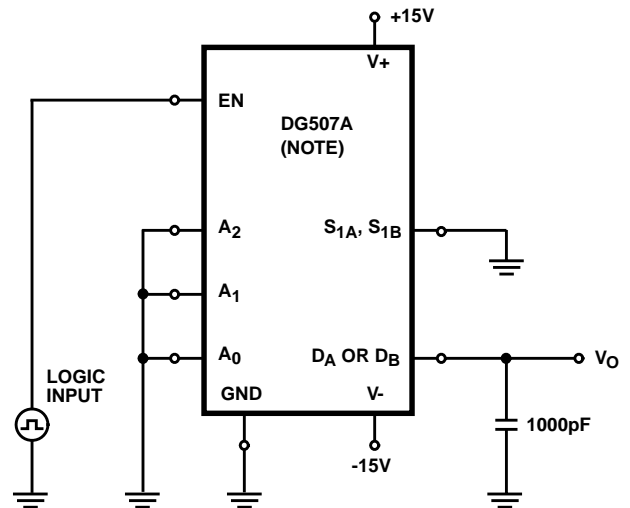

NOTE: Similar connections for DG509A.

FIGURE 4B. DG507A TEST CIRCUIT

Test Circuits and Waveforms (Continued)

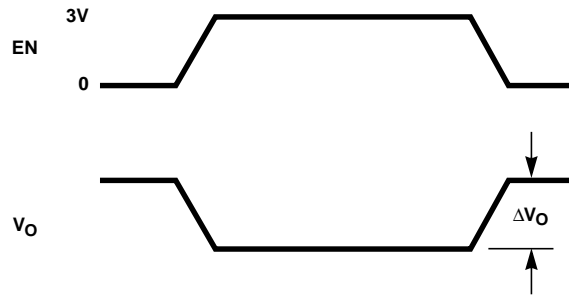

ΔV_O is the measured voltage error due to charge injection.
The charge transfer error in Coulombs is $Q = C_L \times \Delta V_O$.

FIGURE 4C. CHARGE INJECTION WAVEFORMS

FIGURE 4. CHARGE INJECTION

Typical Performance Curves

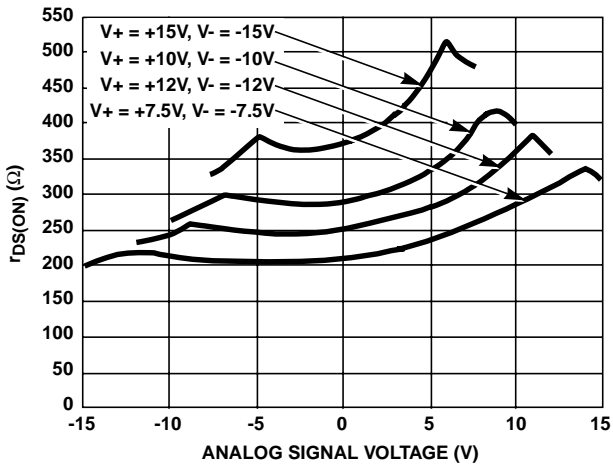

FIGURE 5. $r_{DS(ON)}$ vs ANALOG SIGNAL VOLTAGE vs SUPPLY VOLTAGE

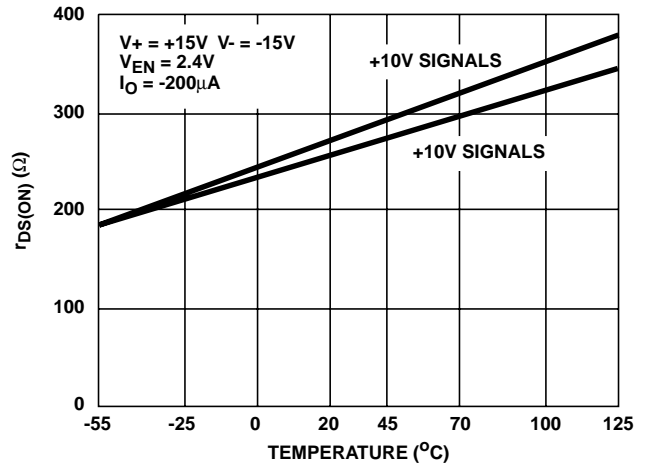

FIGURE 6. TYPICAL $r_{DS(ON)}$ VARIATION WITH TEMPERATURE

Die Characteristics

DIE DIMENSIONS:

3810μm x 2770μm

METALLIZATION:

Type: Al
 Thickness: 10kÅ ±1kÅ

PASSIVATION:

Type: PSG/Nitride
 Thickness: PSG: 7kÅ ±1.4kÅ
 Nitride: 8kÅ ±1.2kÅ

WORST CASE CURRENT DENSITY:

$9.1 \times 10^4 \text{ A/cm}^2$

Metallization Mask Layout

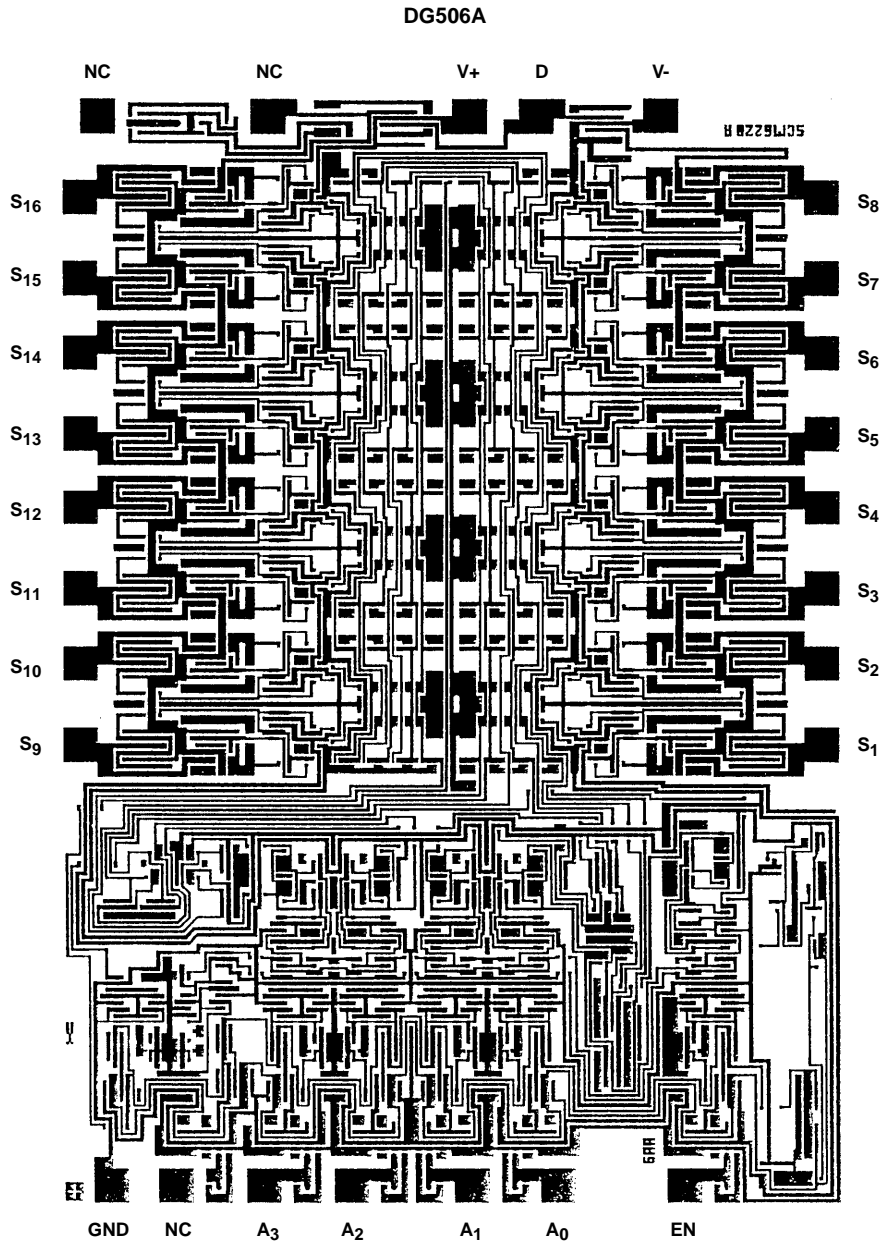

DG507A

Die Characteristics

DIE DIMENSIONS:

3810 μ m x 2770 μ m

METALLIZATION:

Type: Al

Thickness: 10k \AA \pm 1k \AA

PASSIVATION:

Type: PSG/Nitride

Thickness: PSG: 7k \AA \pm 1.4k \AA

Nitride: 8k \AA \pm 1.2k \AA

WORST CASE CURRENT DENSITY:

9.1 x 10⁴ A/cm²

Metallization Mask Layout

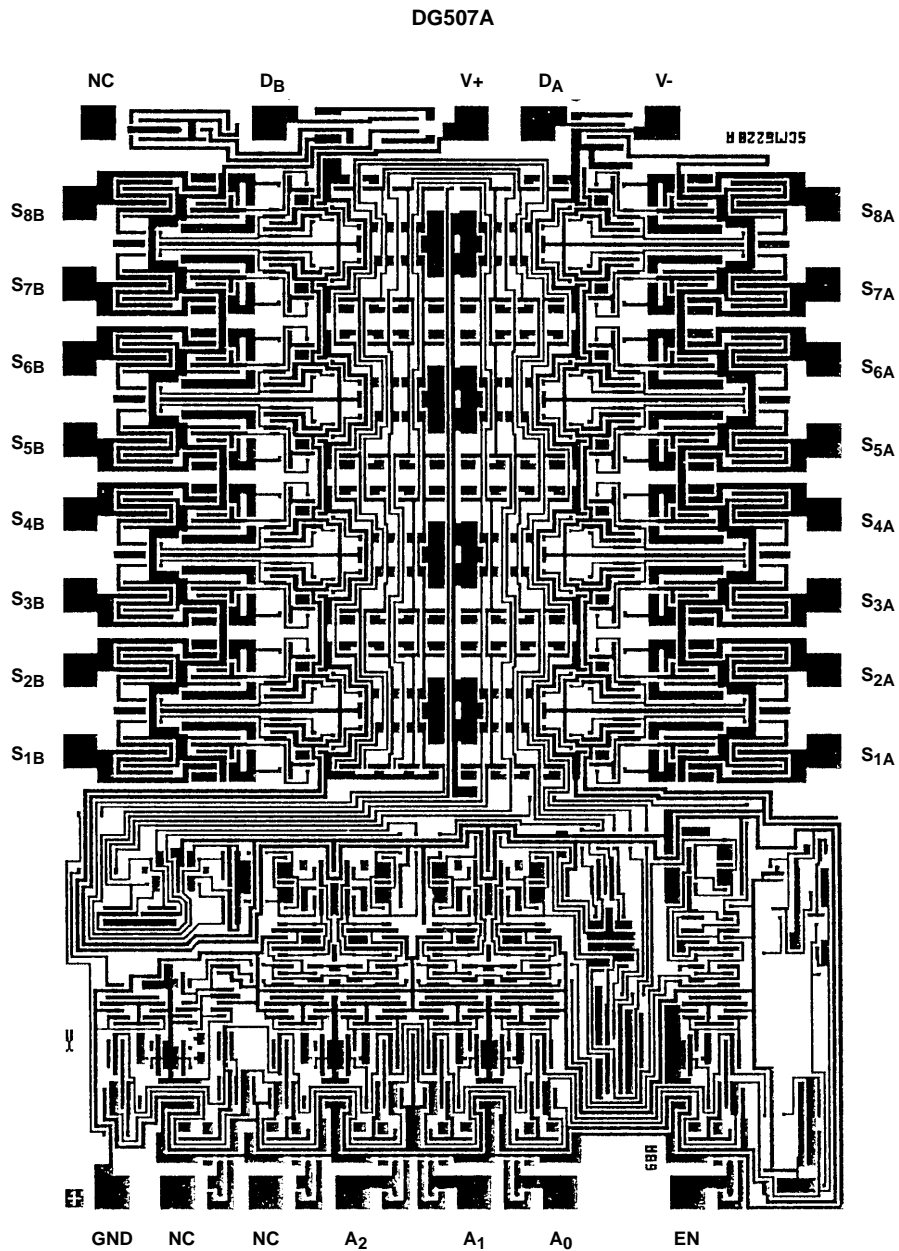

Die Characteristics

DIE DIMENSIONS:

3100 μ m x 2083 μ m

METALLIZATION:

Type: Al
Thickness: 10k \AA \pm 1k \AA

PASSIVATION:

Type: PSG/Nitride
Thickness: PSG: 7k \AA \pm 1.4k \AA ww
Nitride: 8k \AA \pm 1.2k \AA

WORST CASE CURRENT DENSITY:

9.1 x 10⁴ A/cm²

Metallization Mask Layout

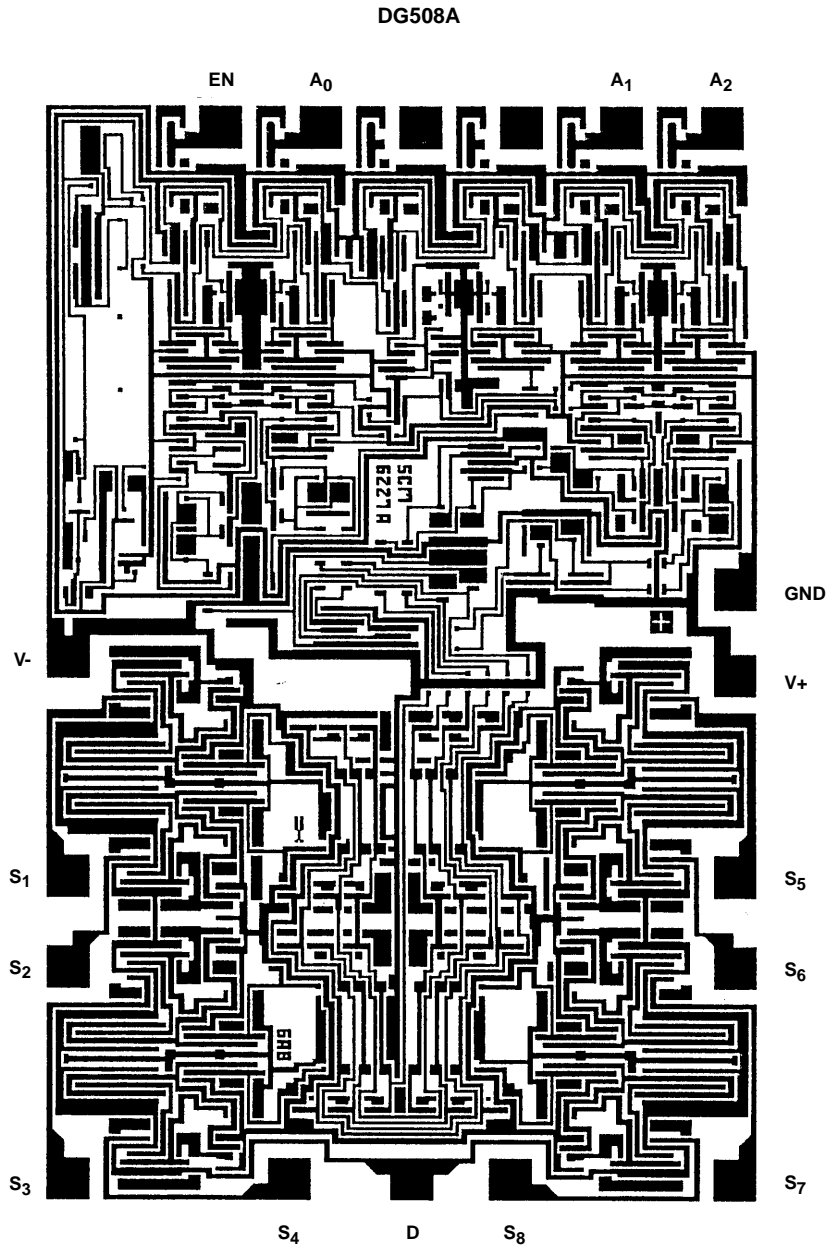

Die Characteristics

DIE DIMENSIONS:

3100μm x 2083μm

METALLIZATION:

Type: Al
 Thickness: 10kÅ ±1kÅ

PASSIVATION:

Type: PSG/Nitride
 Thickness: PSG: 7kÅ ±1.4kÅ
 Nitride: 8kÅ ±1.2kÅ

WORST CASE CURRENT DENSITY:

9.1 x 10⁴ A/cm²

Metallization Mask Layout

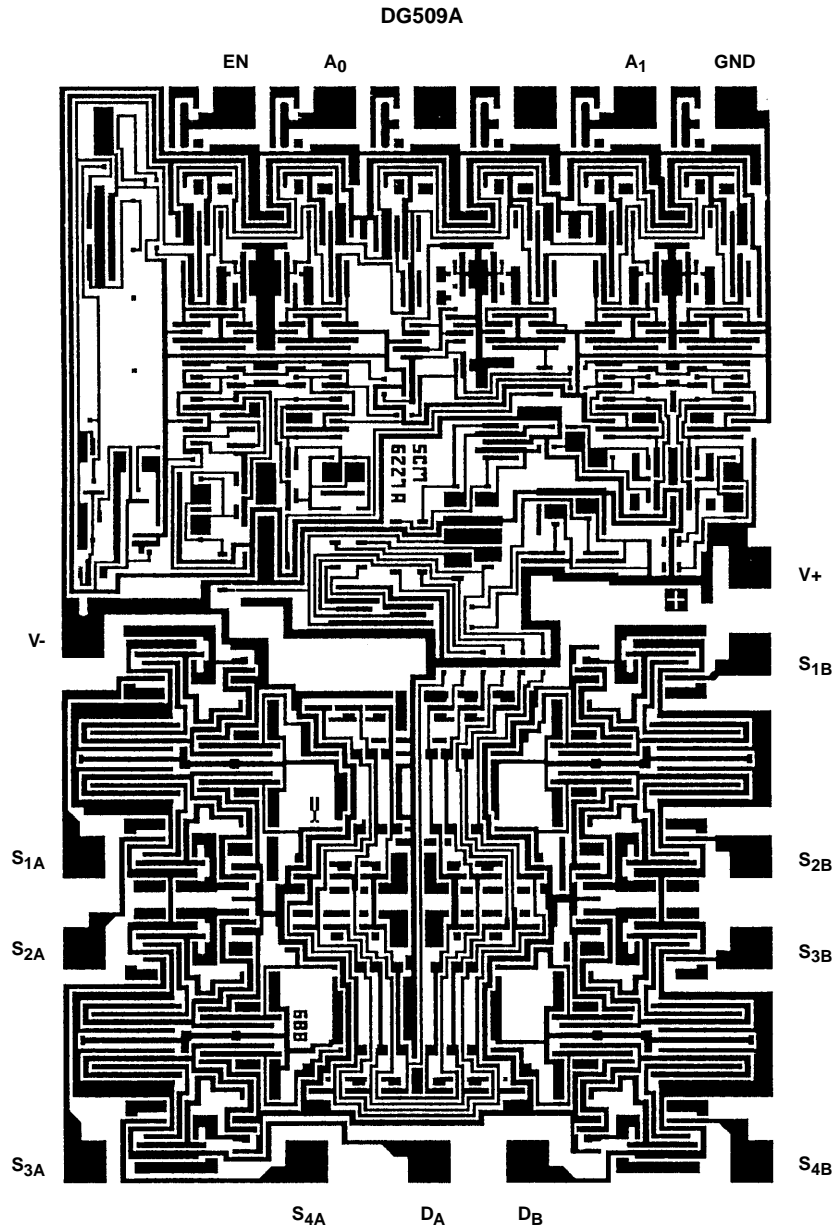

Dual-In-Line Plastic Packages (PDIP)

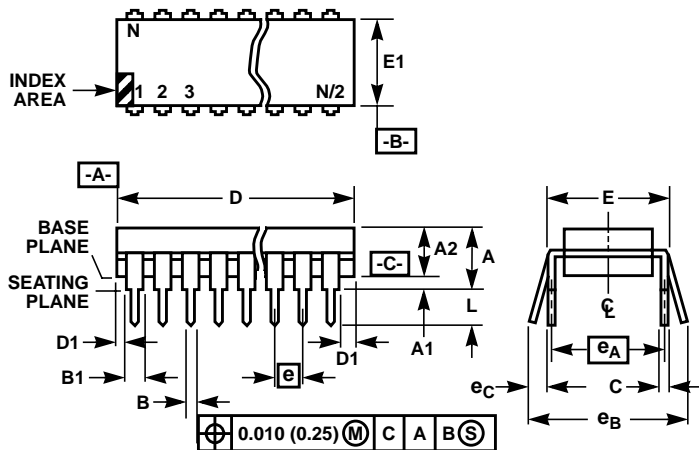

NOTES:

1. Controlling Dimensions: INCH. In case of conflict between English and Metric dimensions, the inch dimensions control.
2. Dimensioning and tolerancing per ANSI Y14.5M-1982.
3. Symbols are defined in the "MO Series Symbol List" in Section 2.2 of Publication No. 95.
4. Dimensions A, A1 and L are measured with the package seated in JEDEC seating plane gauge GS-3.
5. D, D1, and E1 dimensions do not include mold flash or protrusions. Mold flash or protrusions shall not exceed 0.010 inch (0.25mm).
6. E and e_A are measured with the leads constrained to be perpendicular to datum [-C-].
7. e_B and e_C are measured at the lead tips with the leads unconstrained. e_C must be zero or greater.
8. B1 maximum dimensions do not include dambar protrusions. Dambar protrusions shall not exceed 0.010 inch (0.25mm).
9. N is the maximum number of terminal positions.
10. Corner leads (1, N, N/2 and N/2 + 1) for E8.3, E16.3, E18.3, E28.3, E42.6 will have a B1 dimension of 0.030 - 0.045 inch (0.76 - 1.14mm).

E16.3 (JEDEC MS-001-BB ISSUE D)
16 LEAD DUAL-IN-LINE PLASTIC PACKAGE

SYMBOL	INCHES		MILLIMETERS		NOTES
	MIN	MAX	MIN	MAX	
A	-	0.210	-	5.33	4
A1	0.015	-	0.39	-	4
A2	0.115	0.195	2.93	4.95	-
B	0.014	0.022	0.356	0.558	-
B1	0.045	0.070	1.15	1.77	8, 10
C	0.008	0.014	0.204	0.355	-
D	0.735	0.775	18.66	19.68	5
D1	0.005	-	0.13	-	5
E	0.300	0.325	7.62	8.25	6
E1	0.240	0.280	6.10	7.11	5
e	0.100 BSC		2.54 BSC		-
e_A	0.300 BSC		7.62 BSC		6
e_B	-	0.430	-	10.92	7
L	0.115	0.150	2.93	3.81	4
N	16		16		9

Rev. 0 12/93

Dual-In-Line Plastic Packages (PDIP)

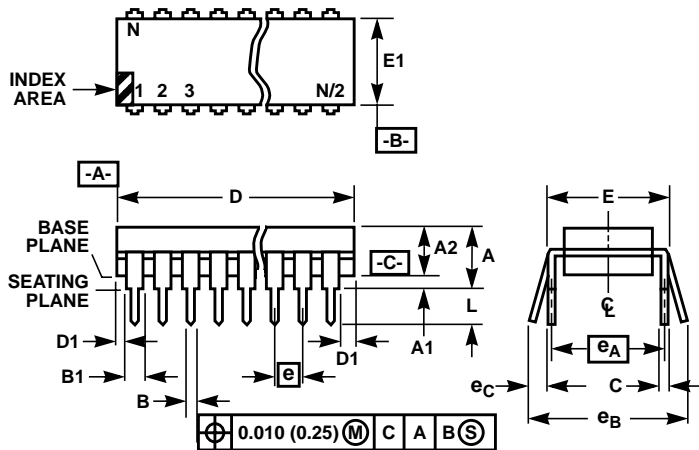

NOTES:

1. Controlling Dimensions: INCH. In case of conflict between English and Metric dimensions, the inch dimensions control.
2. Dimensioning and tolerancing per ANSI Y14.5M-1982.
3. Symbols are defined in the "MO Series Symbol List" in Section 2.2 of Publication No. 95.
4. Dimensions A, A1 and L are measured with the package seated in JEDEC seating plane gauge GS-3.
5. D, D1, and E1 dimensions do not include mold flash or protrusions. Mold flash or protrusions shall not exceed 0.010 inch (0.25mm).
6. E and e_A are measured with the leads constrained to be perpendicular to datum -C-.
7. e_B and e_C are measured at the lead tips with the leads unconstrained. e_C must be zero or greater.
8. B1 maximum dimensions do not include dambar protrusions. Dambar protrusions shall not exceed 0.010 inch (0.25mm).
9. N is the maximum number of terminal positions.
10. Corner leads (1, N, N/2 and N/2 + 1) for E8.3, E16.3, E18.3, E28.3, E42.6 will have a B1 dimension of 0.030 - 0.045 inch (0.76 - 1.14mm).

E28.6 (JEDEC MS-001-BF ISSUE D)
28 LEAD NARROW BODY DUAL-IN-LINE PLASTIC PACKAGE

SYMBOL	INCHES		MILLIMETERS		NOTES
	MIN	MAX	MIN	MAX	
A	-	0.250	-	6.35	4
A1	0.015	-	0.39	-	4
A2	0.125	0.195	3.18	4.95	-
B	0.014	0.022	0.356	0.558	-
B1	0.030	0.070	0.77	1.77	8
C	0.008	0.015	0.204	0.381	-
D	1.380	1.565	35.1	39.7	5
D1	0.005	-	0.13	-	5
E	0.600	0.625	15.24	15.87	6
E1	0.485	0.580	12.32	14.73	5
e	0.100 BSC		2.54 BSC		-
e_A	0.600 BSC		15.24 BSC		6
e_B	-	0.700	-	17.78	7
L	0.115	0.200	2.93	5.08	4
N	28		28		9

Rev. 0 12/93

Small Outline Plastic Packages (SOIC)

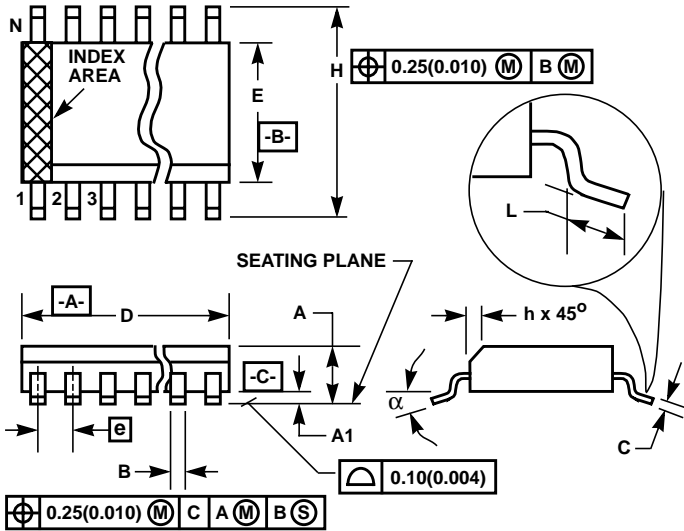

M16.3 (JEDEC MS-013-AA ISSUE C)
16 LEAD WIDE BODY SMALL OUTLINE PLASTIC PACKAGE

SYMBOL	INCHES		MILLIMETERS		NOTES
	MIN	MAX	MIN	MAX	
A	0.0926	0.1043	2.35	2.65	-
A1	0.0040	0.0118	0.10	0.30	-
B	0.013	0.0200	0.33	0.51	9
C	0.0091	0.0125	0.23	0.32	-
D	0.3977	0.4133	10.10	10.50	3
E	0.2914	0.2992	7.40	7.60	4
e	0.050 BSC		1.27 BSC		-
H	0.394	0.419	10.00	10.65	-
h	0.010	0.029	0.25	0.75	5
L	0.016	0.050	0.40	1.27	6
N	16		16		7
α	0°	8°	0°	8°	-

NOTES:

1. Symbols are defined in the "MO Series Symbol List" in Section 2.2 of Publication Number 95.
2. Dimensioning and tolerancing per ANSI Y14.5M-1982.
3. Dimension "D" does not include mold flash, protrusions or gate burrs. Mold flash, protrusion and gate burrs shall not exceed 0.15mm (0.006 inch) per side.
4. Dimension "E" does not include interlead flash or protrusions. Interlead flash and protrusions shall not exceed 0.25mm (0.010 inch) per side.
5. The chamfer on the body is optional. If it is not present, a visual index feature must be located within the crosshatched area.
6. "L" is the length of terminal for soldering to a substrate.
7. "N" is the number of terminal positions.
8. Terminal numbers are shown for reference only.
9. The lead width "B", as measured 0.36mm (0.014 inch) or greater above the seating plane, shall not exceed a maximum value of 0.61mm (0.024 inch)
10. Controlling dimension: MILLIMETER. Converted inch dimensions are not necessarily exact.

Rev. 0 12/93

Small Outline Plastic Packages (SOIC)

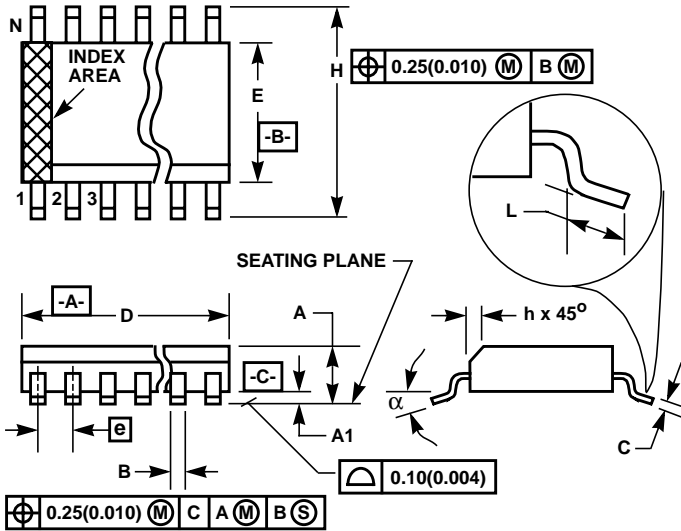

M28.3 (JEDEC MS-013-AE ISSUE C)
28 LEAD WIDE BODY SMALL OUTLINE PLASTIC PACKAGE

SYMBOL	INCHES		MILLIMETERS		NOTES
	MIN	MAX	MIN	MAX	
A	0.0926	0.1043	2.35	2.65	-
A1	0.0040	0.0118	0.10	0.30	-
B	0.013	0.0200	0.33	0.51	9
C	0.0091	0.0125	0.23	0.32	-
D	0.6969	0.7125	17.70	18.10	3
E	0.2914	0.2992	7.40	7.60	4
e	0.05 BSC		1.27 BSC		-
H	0.394	0.419	10.00	10.65	-
h	0.01	0.029	0.25	0.75	5
L	0.016	0.050	0.40	1.27	6
N	28		28		7
alpha	0°	8°	0°	8°	-

NOTES:

1. Symbols are defined in the "MO Series Symbol List" in Section 2.2 of Publication Number 95.
2. Dimensioning and tolerancing per ANSI Y14.5M-1982.
3. Dimension "D" does not include mold flash, protrusions or gate burrs. Mold flash, protrusion and gate burrs shall not exceed 0.15mm (0.006 inch) per side.
4. Dimension "E" does not include interlead flash or protrusions. Interlead flash and protrusions shall not exceed 0.25mm (0.010 inch) per side.
5. The chamfer on the body is optional. If it is not present, a visual index feature must be located within the crosshatched area.
6. "L" is the length of terminal for soldering to a substrate.
7. "N" is the number of terminal positions.
8. Terminal numbers are shown for reference only.
9. The lead width "B", as measured 0.36mm (0.014 inch) or greater above the seating plane, shall not exceed a maximum value of 0.61mm (0.024 inch)
10. Controlling dimension: MILLIMETER. Converted inch dimensions are not necessarily exact.

Rev. 0 12/93

Ceramic Dual-In-Line Frit Seal Packages (CERDIP)

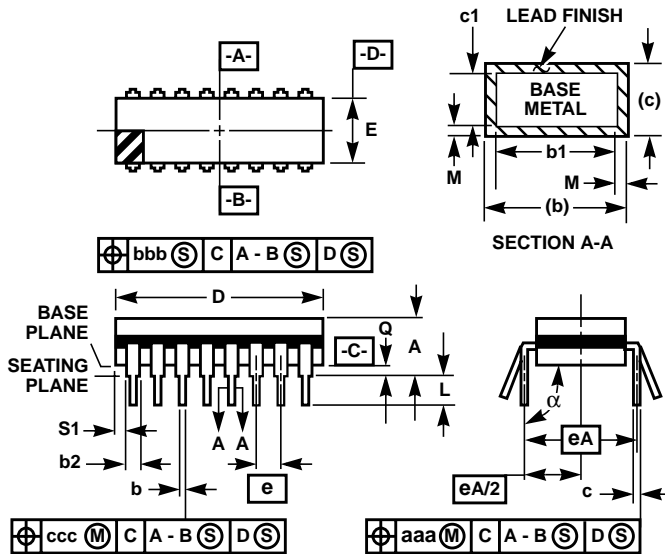

F16.3 MIL-STD-1835 GDIP1-T16 (D-2, CONFIGURATION A)
16 LEAD CERAMIC DUAL-IN-LINE FRIT SEAL PACKAGE

SYMBOL	INCHES		MILLIMETERS		NOTES
	MIN	MAX	MIN	MAX	
A	-	0.200	-	5.08	-
b	0.014	0.026	0.36	0.66	2
b1	0.014	0.023	0.36	0.58	3
b2	0.045	0.065	1.14	1.65	-
b3	0.023	0.045	0.58	1.14	4
c	0.008	0.018	0.20	0.46	2
c1	0.008	0.015	0.20	0.38	3
D	-	0.840	-	21.34	5
E	0.220	0.310	5.59	7.87	5
e	0.100 BSC		2.54 BSC		-
eA	0.300 BSC		7.62 BSC		-
eA/2	0.150 BSC		3.81 BSC		-
L	0.125	0.200	3.18	5.08	-
Q	0.015	0.060	0.38	1.52	6
S1	0.005	-	0.13	-	7
α	90°	105°	90°	105°	-
aaa	-	0.015	-	0.38	-
bbb	-	0.030	-	0.76	-
ccc	-	0.010	-	0.25	-
M	-	0.0015	-	0.038	2, 3
N	16		16		8

NOTES:

1. Index area: A notch or a pin one identification mark shall be located adjacent to pin one and shall be located within the shaded area shown. The manufacturer's identification shall not be used as a pin one identification mark.
2. The maximum limits of lead dimensions b and c or M shall be measured at the centroid of the finished lead surfaces, when solder dip or tin plate lead finish is applied.
3. Dimensions b1 and c1 apply to lead base metal only. Dimension M applies to lead plating and finish thickness.
4. Corner leads (1, N, N/2, and N/2+1) may be configured with a partial lead paddle. For this configuration dimension b3 replaces dimension b2.
5. This dimension allows for off-center lid, meniscus, and glass overrun.
6. Dimension Q shall be measured from the seating plane to the base plane.
7. Measure dimension S1 at all four corners.
8. N is the maximum number of terminal positions.
9. Dimensioning and tolerancing per ANSI Y14.5M - 1982.
10. Controlling dimension: INCH.

Rev. 0 4/94

Ceramic Dual-In-Line Frit Seal Packages (CERDIP)

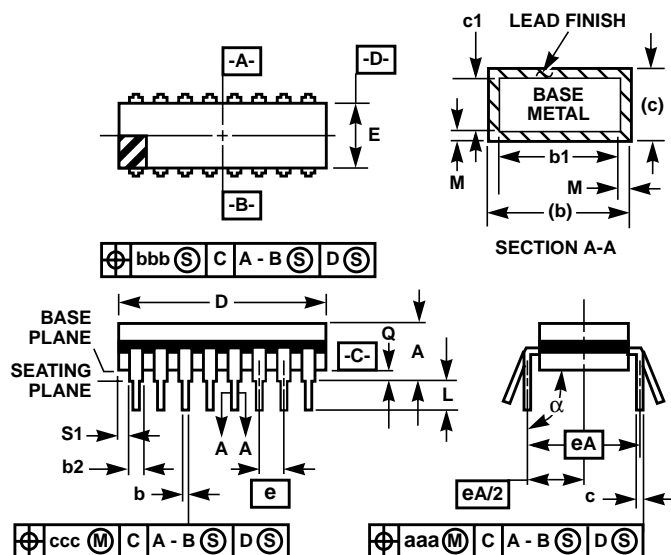

F28.6 MIL-STD-1835 GDIP1-T28 (D-10, CONFIGURATION A)
28 LEAD CERAMIC DUAL-IN-LINE FRIT SEAL PACKAGE

SYMBOL	INCHES		MILLIMETERS		NOTES
	MIN	MAX	MIN	MAX	
A	-	0.232	-	5.92	-
b	0.014	0.026	0.36	0.66	2
b1	0.014	0.023	0.36	0.58	3
b2	0.045	0.065	1.14	1.65	-
b3	0.023	0.045	0.58	1.14	4
c	0.008	0.018	0.20	0.46	2
c1	0.008	0.015	0.20	0.38	3
D	-	1.490	-	37.85	5
E	0.500	0.610	12.70	15.49	5
e	0.100 BSC		2.54 BSC		-
eA	0.600 BSC		15.24 BSC		-
eA/2	0.300 BSC		7.62 BSC		-
L	0.125	0.200	3.18	5.08	-
Q	0.015	0.060	0.38	1.52	6
S1	0.005	-	0.13	-	7
α	90°	105°	90°	105°	-
aaa	-	0.015	-	0.38	-
bbb	-	0.030	-	0.76	-
ccc	-	0.010	-	0.25	-
M	-	0.0015	-	0.038	2, 3
N	28		28		8

NOTES:

1. Index area: A notch or a pin one identification mark shall be located adjacent to pin one and shall be located within the shaded area shown. The manufacturer's identification shall not be used as a pin one identification mark.
2. The maximum limits of lead dimensions b and c or M shall be measured at the centroid of the finished lead surfaces, when solder dip or tin plate lead finish is applied.
3. Dimensions b1 and c1 apply to lead base metal only. Dimension M applies to lead plating and finish thickness.
4. Corner leads (1, N, N/2, and N/2+1) may be configured with a partial lead paddle. For this configuration dimension b3 replaces dimension b2.
5. This dimension allows for off-center lid, meniscus, and glass overrun.
6. Dimension Q shall be measured from the seating plane to the base plane.
7. Measure dimension S1 at all four corners.
8. N is the maximum number of terminal positions.
9. Dimensioning and tolerancing per ANSI Y14.5M - 1982.
10. Controlling dimension: INCH.

Rev. 0 4/94

All Intersil semiconductor products are manufactured, assembled and tested under **ISO9000** quality systems certification.

Intersil semiconductor products are sold by description only. Intersil Corporation reserves the right to make changes in circuit design and/or specifications at any time without notice. Accordingly, the reader is cautioned to verify that data sheets are current before placing orders. Information furnished by Intersil is believed to be accurate and reliable. However, no responsibility is assumed by Intersil or its subsidiaries for its use; nor for any infringements of patents or other rights of third parties which may result from its use. No license is granted by implication or otherwise under any patent or patent rights of Intersil or its subsidiaries.

For information regarding Intersil Corporation and its products, see web site www.intersil.com

Sales Office Headquarters

NORTH AMERICA
Intersil Corporation
P. O. Box 883, Mail Stop 53-204
Melbourne, FL 32902
TEL: (321) 724-7000
FAX: (321) 724-7240

EUROPE
Intersil SA
Mercure Center
100, Rue de la Fusee
1130 Brussels, Belgium
TEL: (32) 2.724.2111
FAX: (32) 2.724.22.05

ASIA
Intersil (Taiwan) Ltd.
7F-6, No. 101 Fu Hsing North Road
Taipei, Taiwan
Republic of China
TEL: (886) 2 2716 9310
FAX: (886) 2 2715 3029

This datasheet has been downloaded from:

www.DatasheetCatalog.com

Datasheets for electronic components.



LittleDiode supplies new, hard to find or obsolete electronic components and semiconductors all over the world.

With over two million different components listed you are sure to find the part you need.

Feel free to visit us today at our online store:

LittleDiode.com

Looking forward to providing you with the best possible service.