

Improved Quad CMOS Analog Switches

FEATURES

- $\pm 22\text{-V}$ Supply Voltage Rating
- CMOS Compatible Logic
- Low On-Resistance— $r_{DS(on)}$: $45\ \Omega$
- Low Leakage— $I_{D(on)}$: $20\ \text{pA}$
- Single Supply Operation Possible
- Extended Temperature Range
- Fast Switching— t_{ON} : $< 200\ \text{ns}$
- Low Glitching— Q : $1\ \text{pC}$

BENEFITS

- Wide Analog Signal Range
- Simple Logic Interface
- Higher Accuracy
- Minimum Transients
- Reduced Power Consumption
- Superior to DG308A/309
- Space Savings (TSSOP)

APPLICATIONS

- Industrial Instrumentation
- Test Equipment
- Communications Systems
- Disk Drives
- Computer Peripherals
- Portable Instruments
- Sample-and-Hold Circuits

DESCRIPTION

The DG308B/309B analog switches are highly improved versions of the industry-standard DG308A/309. These devices are fabricated in Vishay Siliconix' proprietary silicon gate CMOS process, resulting in lower on-resistance, lower leakage, higher speed, and lower power consumption.

These quad single-pole single-throw switches are designed for a wide variety of applications in telecommunications, instrumentation, process control, computer peripherals, etc. An improved charge injection compensation design minimizes

switching transients. The DG308B and DG309B can handle up to $\pm 22\text{-V}$ input signals. An epitaxial layer prevents latchup.

All devices feature true bi-directional performance in the on condition, and will block signals to the supply levels in the off condition.

The DG308B is a normally open switch and the DG309B is a normally closed switch. (See Truth Table.)

FUNCTIONAL BLOCK DIAGRAM AND PIN CONFIGURATION

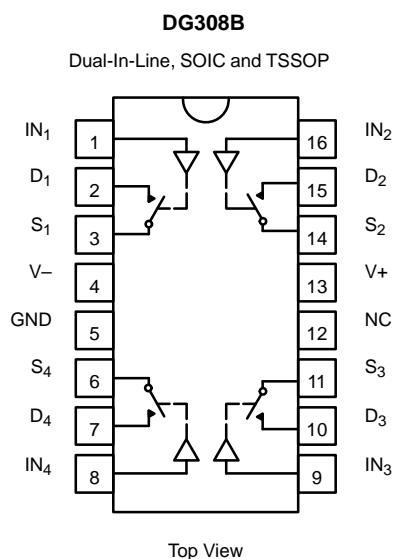

TRUTH TABLE

Logic	DG308B	DG309B
0	OFF	ON
1	ON	OFF

Logic "0" $\leq 3.5\text{V}$
Logic "1" $\geq 11\text{V}$

ORDERING INFORMATION

Temp Range	Package	Part Number
-40 to 85°C	16-Pin Plastic DIP	DG308BDJ
		DG309BDJ
	16-Pin Narrow SOIC	DG308BDY
		DG309BDY
	16-Pin TSSOP	DG308BDQ
		DG309BDQ
-55 to 125°C	16-Pin CerDIP	DG308BAK
		DG308BAK/883
		DG309BAK
		DG309BAK/883



ABSOLUTE MAXIMUM RATINGS

Voltages Referenced to V-

V+	44 V
GND	25 V
Digital Inputs ^a V _S , V _D	(V-) -2 V to (V+) +2 V or 30 mA, whichever occurs first
Current, Any Terminal	30 mA
Peak Current, S or D (Pulsed at 1 ms, 10% duty cycle max)	100 mA
Storage Temperature (AK, Suffix)	-65 to 150°C
(DJ, DY, DQ Suffix)	-65 to 125°C

Power Dissipation (Package)^b

16-Pin Plastic DIP ^c	470 mW
16-Pin Narrow SOIC and TSSOP ^d	640 mW
16-Pin CerDIP ^e	900 mW

Notes:

- Signals on S_X, D_X, or I_{NX} exceeding V+ or V- will be clamped by internal diodes. Limit forward diode current to maximum current ratings.
- All leads welded or soldered to PC Board.
- Derate 6.5 mW/°C above 75°C
- Derate 7.6 mW/°C above 75°C
- Derate 12 mW/°C above 75°C

SPECIFICATIONS ^a									
Parameter	Symbol	Test Conditions Unless Specified V+ = 15 V, V- = -15 V V _{IN} = 11 V, 3.5 V ^f	Temp ^b	Typ ^c	A Suffix -55 to 125°C		D Suffix -40 to 85°C		Unit
					Min ^d	Max ^d	Min ^d	Max ^d	
Analog Switch									
Analog Signal Range ^e	V _{ANALOG}		Full		-15	15	-15	15	V
Drain-Source On-Resistance	r _{DS(on)}	V _D = ±10 V, I _S = 1 mA	Room	45		85		85	Ω
			Full			100		100	
r _{DS(on)} Match	Δr _{DS(on)}		Room	2					%
Source Off Leakage Current	I _{S(off)}	V _S = ±14 V, V _D = ∓14 V	Room	±0.01	-0.5	0.5	-0.5	0.5	nA
			Full		-20	20	-5	5	
Drain Off Leakage Current	I _{D(off)}	V _D = ±14 V, V _S = ∓14 V	Room	±0.01	-0.5	0.5	-0.5	0.5	
			Full		-20	20	-5	5	
Drain On Leakage Current	I _{D(on)}	V _S = V _D = ±14 V	Room	±0.02	-0.5	0.5	-0.5	0.5	nA
			Full		-40	40	-10	10	
Digital Control									
Input Voltage High	V _{INH}		Full		11		11		V
Input Voltage Low	V _{INL}		Full			3.5		3.5	
Input Current	I _{INH} or I _{INL}	V _{INH} or V _{INL}	Full		-1	1	-1	1	μA
Input Capacitance	C _{IN}		Room	5					pF
Dynamic Characteristics									
Turn-On Time	t _{ON}	V _S = 3 V, See Figure 2	Room			200		200	ns
Turn-Off Time	t _{OFF}		Room			150		150	
Charge Injection	Q	C _L = 1000 pF, V _g = 0 V, R _g = 0 Ω	Room	1					pC
Source-Off Capacitance	C _{S(off)}	V _S = 0 V, f = 1 MHz	Room	5					pF
Drain-Off Capacitance	C _{D(off)}		Room	5					
Channel On Capacitance	C _{D(on)}	V _D = V _S = 0 V, f = 1 MHz	Room	16					
Off Isolation	OIRR	C _L = 15 pF, R _L = 50 Ω V _S = 1 V _{RMS} , f = 100 kHz	Room	90					dB
Channel-to-Channel Crosstalk	X _{TALK}		Room	95					



SPECIFICATIONS ^a									
Parameter	Symbol	Test Conditions Unless Specified $V_+ = 15\text{ V}, V_- = -15\text{ V}$ $V_{IN} = 11\text{ V}, 3.5\text{ V}^f$	Temp ^b	Typ ^c	A Suffix -55 to 125°C		D Suffix -40 to 85°C		Unit
					Min ^d	Max ^d	Min ^d	Max ^d	
Power Supply									
Positive Supply Current	I+	$V_{IN} = 0\text{ or }15\text{ V}$	Room Full			1 5		1 5	μA
Negative Supply Current	I-		Room Full		-1 -5		-1 -5		
Power Supply Range for Continuous Operation	V _{OP}		Full		±4	±22	±4	±22	V

SPECIFICATIONS ^a FOR SINGLE SUPPLY									
Parameter	Symbol	Test Conditions Unless Specified $V_+ = 12\text{ V}, V_- = 0\text{ V}$ $V_{IN} = 11\text{ V}, 3.5\text{ V}^f$	Temp ^b	Typ ^c	A Suffix -55 to 125°C		D Suffix -40 to 85°C		Unit
					Min ^d	Max ^d	Min ^d	Max ^d	
Analog Switch									
Analog Signal Range ^e	V _{ANALOG}		Full		0	12	0	12	V
Drain-Source On-Resistance	r _{DS(on)}	$V_D = 3\text{ V}, 8\text{ V}, I_S = 1\text{ mA}$	Room Full	90		160 200		160 200	Ω
Dynamic Characteristics									
Turn-On Time	t _{ON}	$V_S = 8\text{ V}, \text{ See Figure 2}$	Room			300		300	ns
Turn-Off Time	t _{OFF}		Room			200		200	
Charge Injection	Q	$C_L = 1\text{ nF}, V_{\text{gen}} = 6\text{ V}, R_{\text{gen}} = 0\ \Omega$	Room	4					pC
Power Supply									
Positive Supply Current	I+	$V_{IN} = 0\text{ or }12\text{ V}$	Room Full			1 5		1 5	μA
Negative Supply Current	I-		Room Full		-1 -5		-1 -5		
Power Supply Range for Continuous Operation	V _{OP}		Full		4	44	4	44	V

Notes:

- a. Refer to PROCESS OPTION FLOWCHART.
- b. Room = 25°C, Full = as determined by the operating temperature suffix.
- c. Typical values are for DESIGN AID ONLY, not guaranteed nor subject to production testing.
- d. The algebraic convention whereby the most negative value is a minimum and the most positive a maximum, is used in this data sheet.
- e. Guaranteed by design, not subject to production test.
- f. V_{IN} = input voltage to perform proper function.



TYPICAL CHARACTERISTICS (25°C UNLESS NOTED)

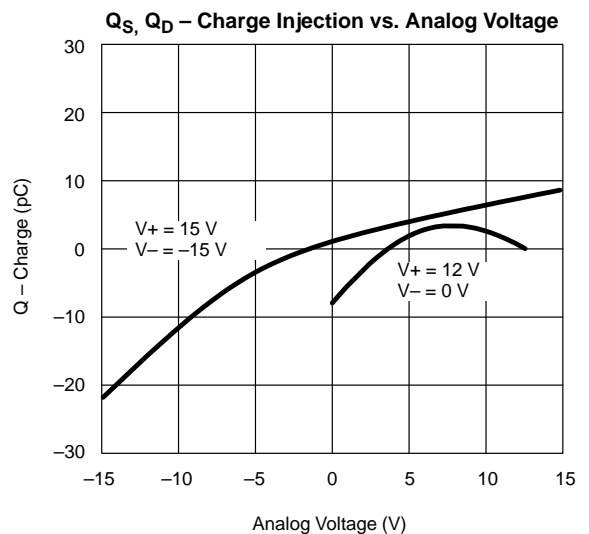
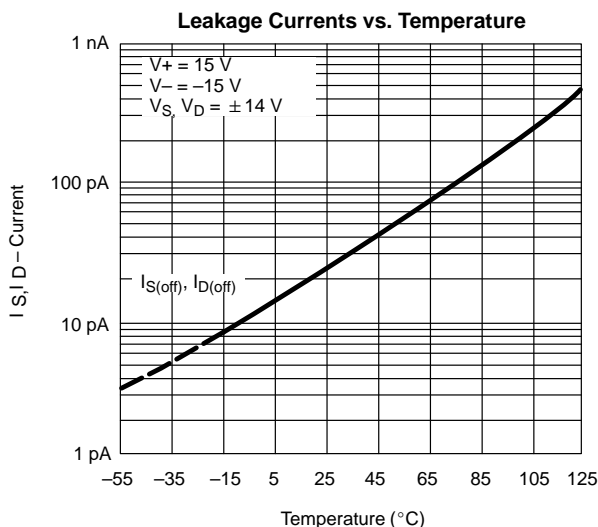
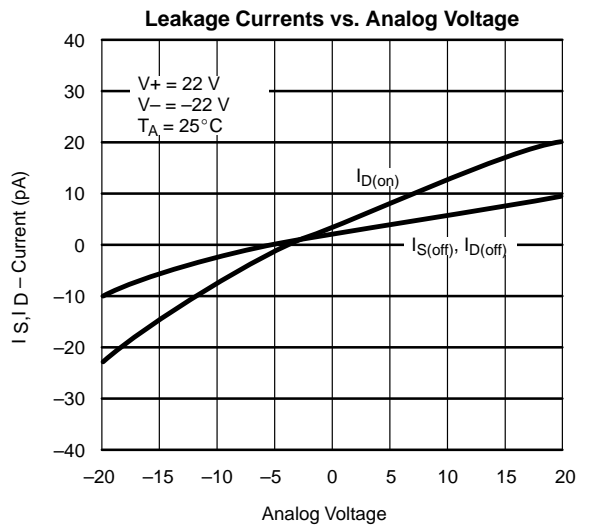
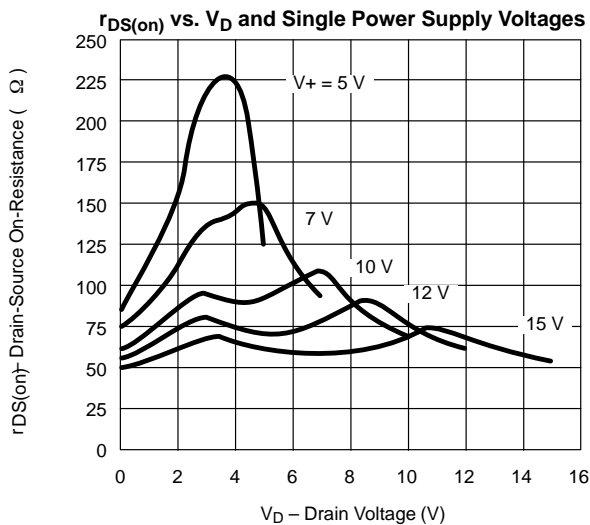
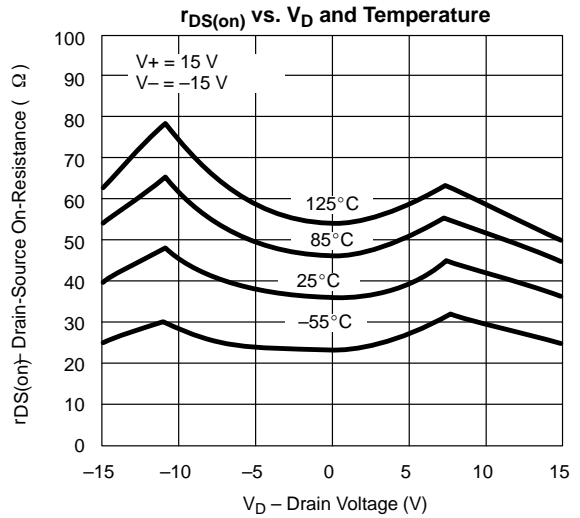
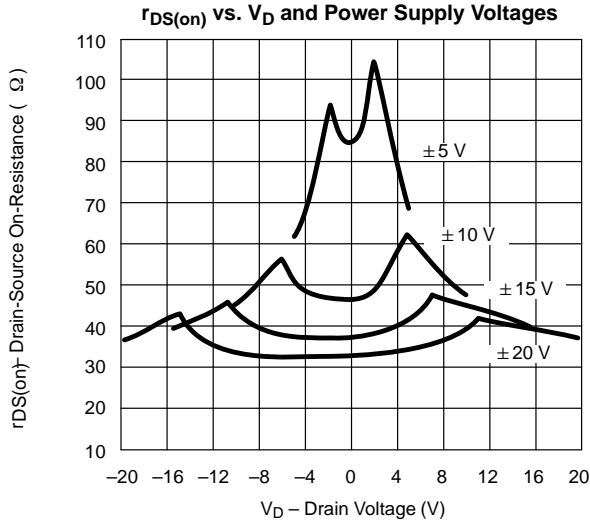

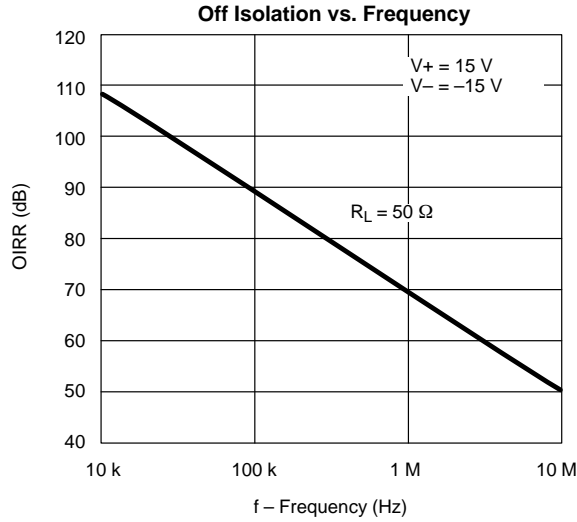
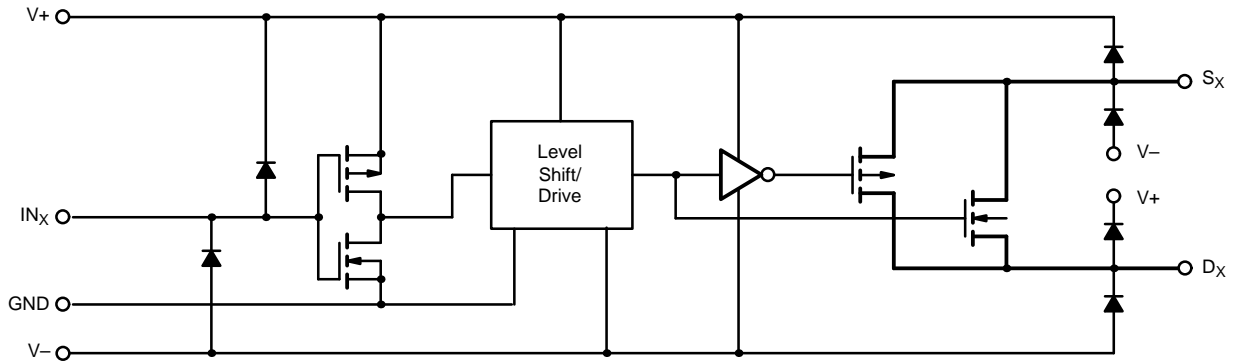
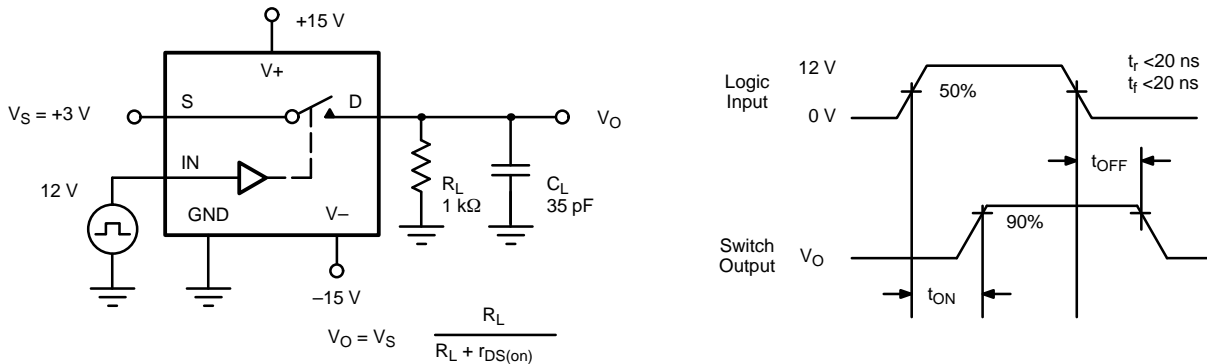
TYPICAL CHARACTERISTICS (25°C UNLESS NOTED)

SCHEMATIC DIAGRAM (TYPICAL CHANNEL)

FIGURE 1.
TEST CIRCUITS

FIGURE 2. Switching Time

TEST CIRCUITS

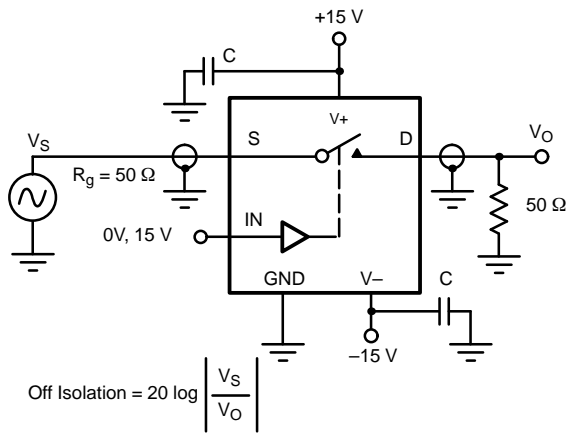

FIGURE 3. Off Isolation

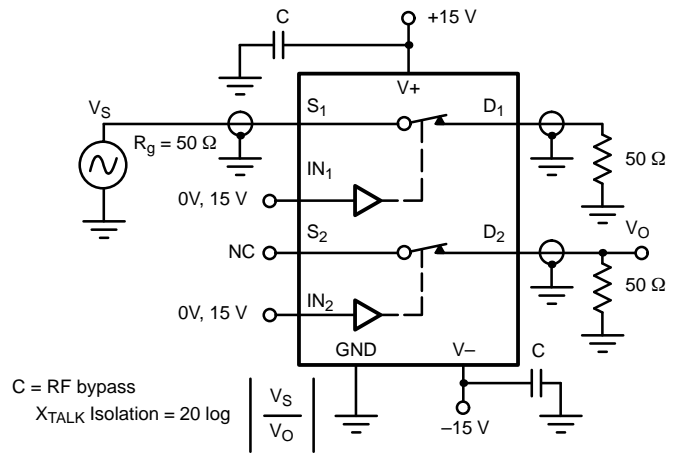
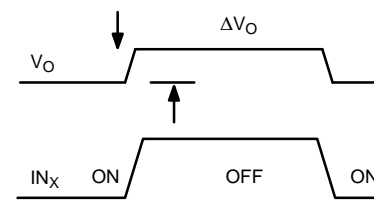
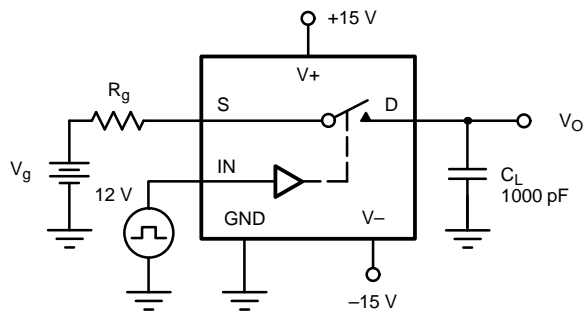

FIGURE 4. Channel-to-Channel Crosstalk



ΔV_O = measured voltage error due to charge injection
The charge injection in coulombs is $Q = C_L \times \Delta V_O$

FIGURE 5. Charge Injection

APPLICATIONS

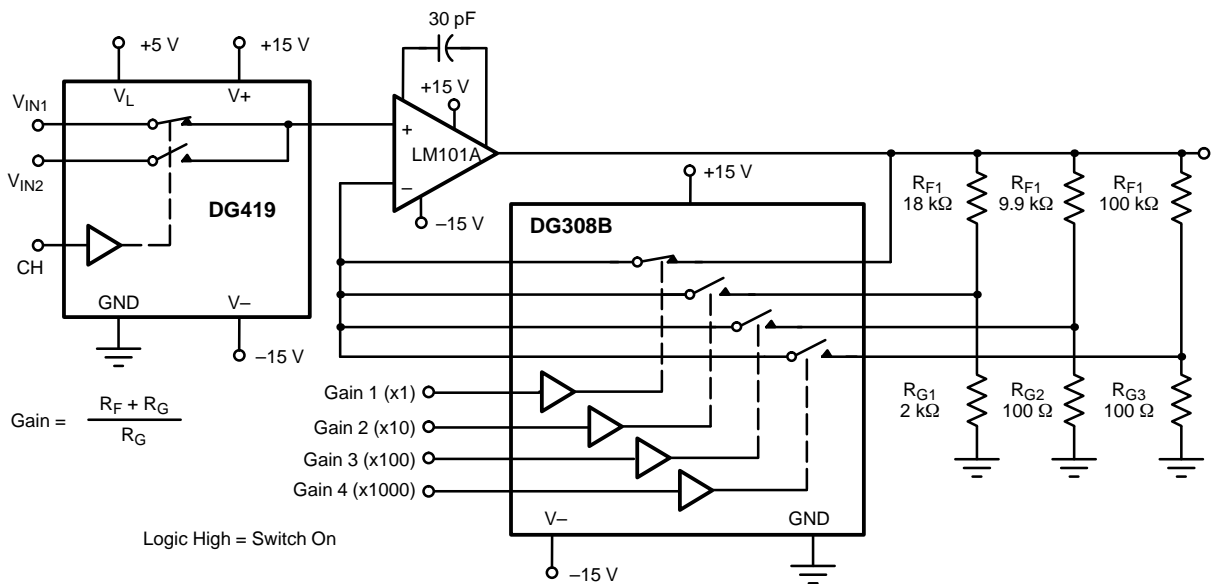
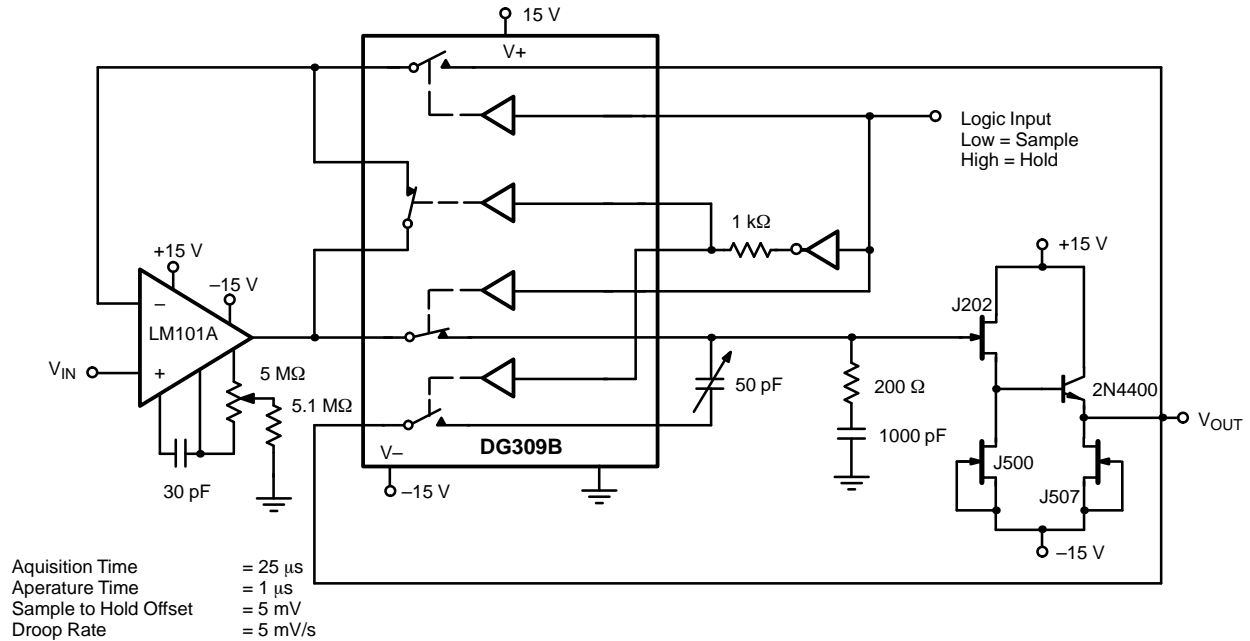
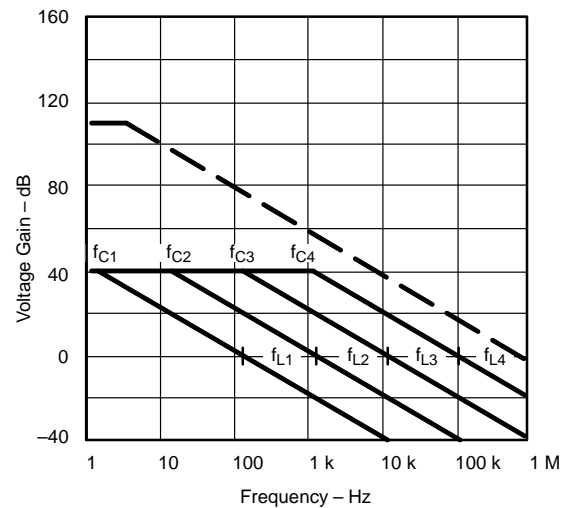
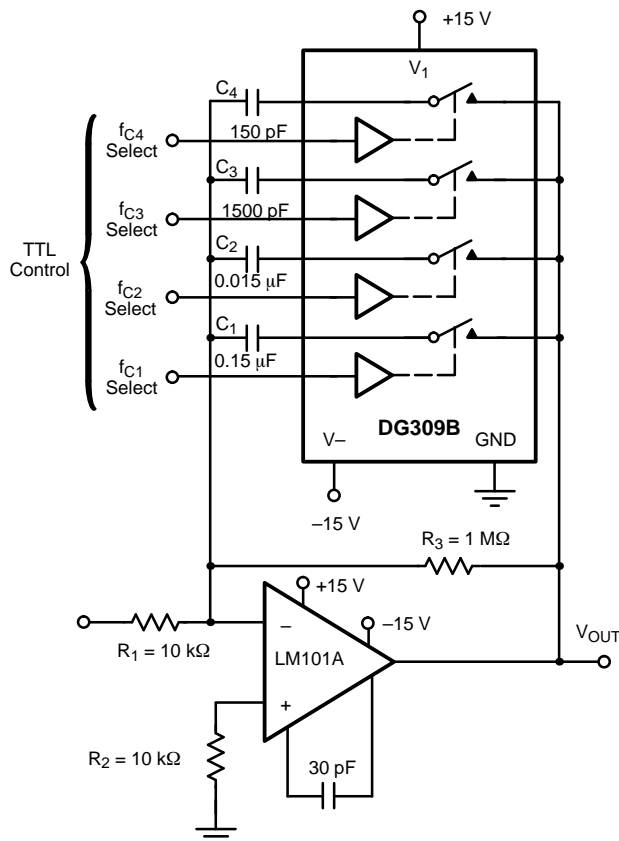

FIGURE 6. A Precision Amplifier with Digitally Programmable Inputs and Gains

APPLICATIONS

FIGURE 7. Sample-and-Hold

$$A_L \text{ (Voltage Gain Below Break Frequency)} = \frac{R_3}{R_1} = 100 \text{ (40 dB)}$$

$$f_C \text{ (Break Frequency)} = \frac{1}{2\pi R_3 C_X}$$

$$f_L \text{ (Unity Gain Frequency)} = \frac{1}{2\pi R_1 C_X}$$

$$\text{Max Attenuation} = \frac{r_{DS(on)}}{10 \text{ k}\Omega} \approx -40 \text{ dB}$$

FIGURE 8. Active Low Pass Filter with Digitally Selected Break Frequency



LittleDiode supplies new, hard to find or obsolete electronic components and semiconductors all over the world.

With over two million different components listed you are sure to find the part you need.

Feel free to visit us today at our online store:

LittleDiode.com

Looking forward to providing you with the best possible service.