

DATA SHEET

DAC-08 SERIES

8-bit high-speed multiplying D/A converter

Product data
Supersedes data of 1994 Aug 31
File under Integrated Circuits, Handbook IC11

2001 Aug 03

8-bit high-speed multiplying D/A converter

DAC-08 Series

DESCRIPTION

The DAC-08 series of 8-bit monolithic multiplying Digital-to-Analog Converters provide very high-speed performance coupled with low cost and outstanding applications flexibility.

Advanced circuit design achieves 70 ns settling times with very low glitch and at low power consumption. Monotonic multiplying performance is attained over a wide 20-to-1 reference current range. Matching to within 1 LSB between reference and full-scale currents eliminates the need for full-scale trimming in most applications. Direct interface to all popular logic families with full noise immunity is provided by the high swing, adjustable threshold logic inputs.

Dual complementary outputs are provided, increasing versatility and enabling differential operation to effectively double the peak-to-peak output swing. True high voltage compliance outputs allow direct output voltage conversion and eliminate output op amps in many applications.

All DAC-08 series models guarantee full 8-bit monotonicity and linearities as tight as 0.1% over the entire operating temperature range. Device performance is essentially unchanged over the ± 4.5 V to ± 18 V power supply range, with 37 mW power consumption attainable at ± 5 V supplies.

The compact size and low power consumption make the DAC-08 attractive for portable and military aerospace applications.

FEATURES

- Fast settling output current—70 ns
- Full-scale current prematched to ± 1 LSB
- Direct interface to TTL, CMOS, ECL, HTL, PMOS
- Relative accuracy to 0.1% maximum over temperature range
- High output compliance -10 V to $+18$ V
- True and complemented outputs
- Wide range multiplying capability
- Low FS current drift — ± 10 ppm/ $^{\circ}$ C
- Wide power supply range— ± 4.5 V to ± 18 V
- Low power consumption—37 mW at ± 5 V

APPLICATIONS

- 8-bit, 1 μ s A-to-D converters
- Servo-motor and pen drivers
- Waveform generators
- Audio encoders and attenuators
- Analog meter drivers
- Programmable power supplies
- CRT display drivers
- High-speed modems
- Other applications where low cost, high speed and complete input/output versatility are required
- Programmable gain and attenuation
- Analog-Digital multiplication

PIN CONFIGURATIONS

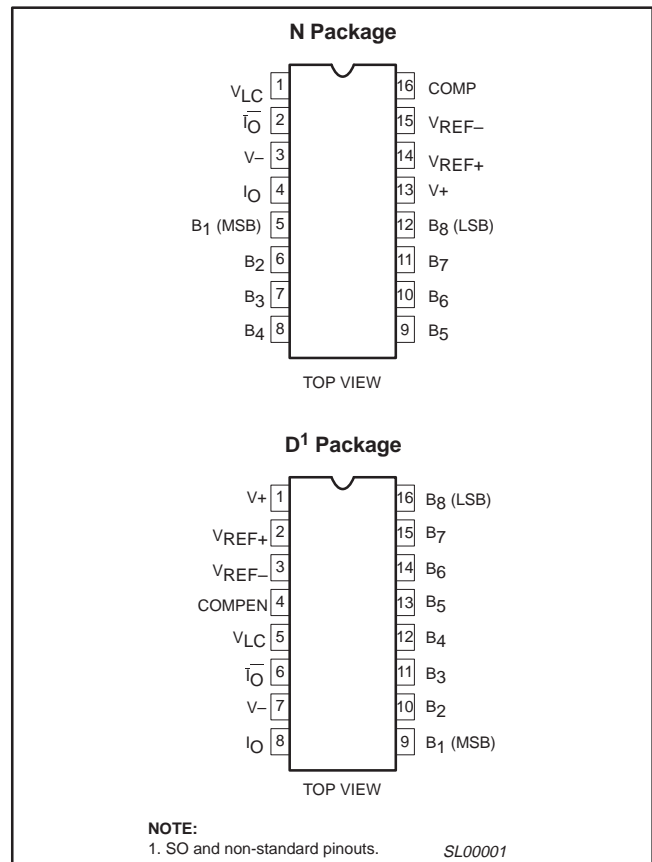

Figure 1. Pin Configuration

8-bit high-speed multiplying D/A converter

DAC-08 Series

ORDERING INFORMATION

DESCRIPTION	TEMPERATURE RANGE	ORDER CODE	DWG #
16-Pin Plastic Dual In-Line Package (DIP)	0 to +70°C	DAC-08CN	SOT38-4
16-Pin Plastic Dual In-Line Package (DIP)	0 to +70°C	DAC-08EN	SOT38-4
16-Pin Plastic Small Outline (SO) Package	0 to +70°C	DAC-08ED	SOT109-1
16-Pin Plastic Dual In-Line Package (DIP)	0 to +70°C	DAC-08HN	SOT38-4

BLOCK DIAGRAM

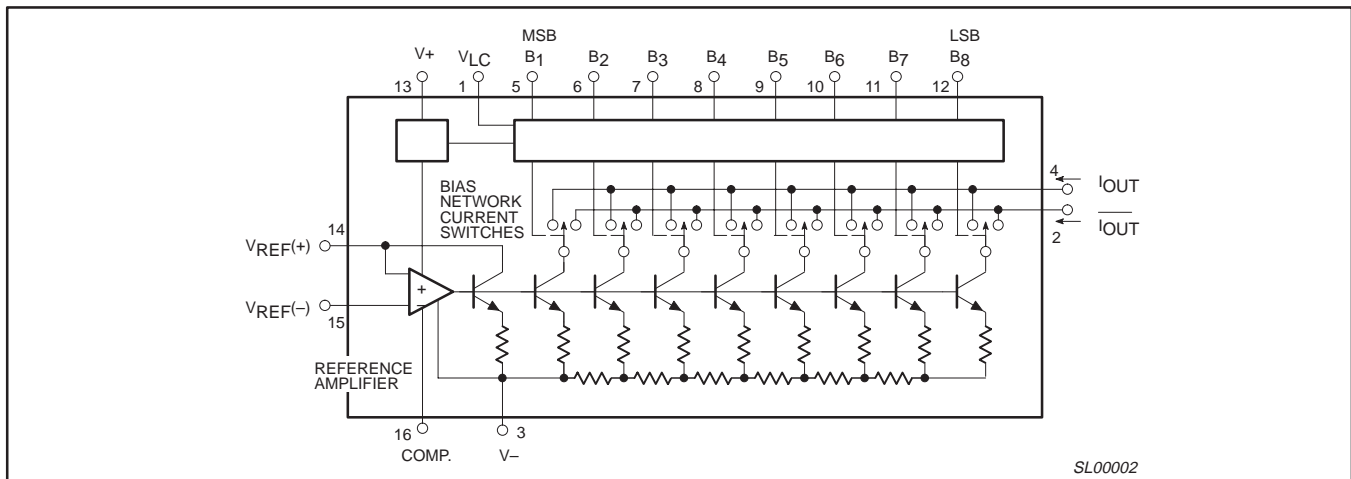

Figure 2. Block Diagram

ABSOLUTE MAXIMUM RATINGS

SYMBOL	PARAMETER	RATING	UNIT
V+ to V-	Power supply voltage	36	V
V ₅ -V ₁₂	Digital input voltage	V- to V- plus 36 V	
V _{LC}	Logic threshold control	V- to V+	
V ₀	Applied output voltage	V- to +18	V
I ₁₄	Reference current	5.0	mA
V ₁₄ , V ₁₅	Reference amplifier inputs	V _{EE} to V _{CC}	
P _D	Maximum power dissipation T _{amb} = 25 °C (still-air) ¹		
	N package	1450	mW
	D package	1090	mW
T _{SOLD}	Lead soldering temperature (10 sec max)	230	°C
T _{amb}	Operating temperature range	0 to +70	°C
T _{stg}	Storage temperature range	-65 to +150	°C

NOTE:

- Derate above 25 °C, at the following rates:
 N package at 11.6mW/°C
 D package at 8.7mW/°C

8-bit high-speed multiplying D/A converter

DAC-08 Series

DC ELECTRICAL CHARACTERISTICS

Pin 3 must be at least 3 V more negative than the potential to which R₁₅ is returned. V_{CC} = ±15V, I_{REF} = 2.0 mA.
Output characteristics refer to both I_{OUT} and I_{OUT} unless otherwise noted. T_{amb} = 0 °C to 70 °C.

SYMBOL	PARAMETER	TEST CONDITIONS	DAC-08C			DAC-08E			UNIT
			Min	Typ	Max	Min	Typ	Max	
	Resolution		8	8	8	8	8	8	Bits
	Monotonicity		8	8	8	8	8	8	Bits
	Relative accuracy	Over temperature range			±0.39			±0.19	%FS
	Differential non-linearity				±0.78			±0.39	%FS
TCI _{FS}	Full-scale tempco			±10			±10		ppm/°C
V _{OC}	Output voltage compliance	Full-scale current change < 1/2LSB	-10		+18	-10		+18	V
I _{FS4}	Full-scale current	V _{REF} = 10.000V; R ₁₄ , R ₁₅ = 5.000 kΩ	1.94	1.99	2.04	1.94	1.99	2.04	mA
I _{FSS}	Full-scale symmetry	I _{FS4} - I _{FS2}		±2.0	±16		±1.0	±8.0	μA
I _{ZS}	Zero-scale current			0.2	4.0		0.2	2.0	μA
I _{FSR}	Full-scale output current range	R ₁₄ , R ₁₅ = 5.000 kΩ V _{REF} = +15.0 V, V ₋ = -10 V V _{REF} = +25.0 V, V ₋ = -12 V	2.1 4.2			2.1 4.2			mA mA
V _{IL} V _{IH}	Logic input levels Low High	V _{LC} = 0 V			0.8			0.8	V V
I _{IL} I _{IH}	Logic input current Low High	V _{LC} = 0 V V _{IN} = -10 V to +0.8 V V _{IN} = 2.0 V to 18 V		-2.0 0.002	-10 10		-2.0 0.002	-10 10	μA μA
V _{IS}	Logic input swing	V ₋ = -15 V	-10		+18	-10		+18	V
V _{THR}	Logic threshold range	V _S = ±15 V	-10		+13.5	-10		+13.5	V
I ₁₅	Reference bias current			-1.0	-3.0		-1.0	-3.0	μA
dl/dt	Reference input slew rate		4.0	8.0		4.0	8.0		mA/μs
PSSI _{FS+} PSI _{FS-}	Power supply sensitivity Positive Negative	I _{REF} = 1 mA V ₊ = 4.5 to 5.5 V, V ₋ = -15 V; V ₊ = 13.5 to 16.5 V, V ₋ = -15 V V ₋ = -4.5 to -5.5 V, V ₊ = +15 V; V ₋ = -13.5 to -16.5 V, V ₊ = +15 V		0.0003 0.002	0.01 0.01		0.0003 0.002	0.01 0.01	%FS/%V _S %FS/%V _S
I ₊ I ₋	Power supply current Positive Negative	V _S = ±5 V, I _{REF} = 1.0 mA		3.1 -4.3	3.8 -5.8		3.1 -4.3	3.8 -5.8	mA mA
I ₊ I ₋	Positive Negative	V _S = +5 V, -15 V, I _{REF} = 2.0 mA		3.1 -7.1	3.8 -7.8		3.1 -7.1	3.8 -7.8	mA mA
I ₊ I ₋	Positive Negative	V _S = ±15 V, I _{REF} = 2.0 mA		3.2 -7.2	3.8 -7.8		3.2 -7.2	3.8 -7.8	mA mA
P _D	Power dissipation	±5 V, I _{REF} = 1.0 mA +5 V, -15 V, I _{REF} = 2.0 mA ±15 V, I _{REF} = 2.0 mA		37 122 156	48 136 174		37 122 156	48 136 174	mW mW mW

8-bit high-speed multiplying D/A converter

DAC-08 Series

DC ELECTRICAL CHARACTERISTICS (Continued)

Pin 3 must be at least 3 V more negative than the potential to which R₁₅ is returned. V_{CC} = +15 V, I_{REF} = 2.0 mA.

Output characteristics refer to both I_{OUT} and $\overline{I_{OUT}}$, unless otherwise noted. T_{amb} = 0 °C to 70 °C.

SYMBOL	PARAMETER	TEST CONDITIONS	DAC-08H			UNIT
			Min	Typ	Max	
	Resolution		8	8	8	Bits
	Monotonicity		8	8	8	Bits
	Relative accuracy	Over temperature range			±0.1	%FS
	Differential non-linearity				±0.19	%FS
TCI _{FS}	Full-scale tempco			±10	±50	ppm/°C
V _{OC}	Output voltage compliance	Full-scale current change 1/2LSB	-10		+18	V
I _{FS4}	Full-scale current	V _{REF} = 10.000 V, R ₁₄ , R ₁₅ = 5.000 kΩ	1.984	1.992	2.000	mA
I _{FSS}	Full-scale symmetry	I _{FS4} - I _{FS2}		±1.0	±4.0	μA
I _{ZS}	Zero-scale current			0.2	1.0	μA
I _{FSR}	Full-scale output current range	R ₁₄ , R ₁₅ = 5.000 kΩ V _{REF} = +15.0 V, V ₋ = -10 V V _{REF} = +25.0 V, V ₋ = -12 V	2.1 4.2			mA mA
V _{IL}	Logic input levels	V _{LC} = 0 V			0.8	V
V _{IH}	Low High		2.0			V V
I _{IL}	Logic input current	V _{LC} = 0 V				
I _{IH}	Low High	V _{IN} = -10 V to +0.8 V V _{IN} = 2.0 V to 18 V		-2.0 0.002	-10 10	μA μA
V _{IS}	Logic input swing	V ₋ = -15 V	-10		+18	V
V _{THR}	Logic threshold range	V _S = ±15 V	-10		+13.5	V
I ₁₅	Reference bias current			-1.0	-3.0	μA
dl/dt	Reference input slew rate		4.0	8.0		mA/μs
PSSI _{FS+}	Power supply sensitivity	I _{REF} = 1 mA				
	Positive	V ₊ = 4.5 to 5.5 V, V ₋ = -15 V; V ₊ = 13.5 to 16.5 V, V ₋ = -15 V		0.0003	0.01	%FS/%VS
PSI _{FS-}	Negative	V ₋ = -4.5 to -5.5 V, V ₊ = +15 V; V ₋ = -13.5 to -16.5 V, V ₊ = +15 V		0.002	0.01	%FS/%VS
I ₊	Power supply current					
I ₋	Positive Negative	V _S = ±5 V, I _{REF} = 1.0 mA		3.1 -4.3	3.8 -5.8	mA mA
I ₊	Positive	V _S = +5 V, -15 V, I _{REF} = 2.0 mA		3.1	3.8	mA
I ₋	Negative			-7.1	-7.8	mA
I ₊	Positive	V _S = ±15 V, I _{REF} = 2.0 mA		3.2	3.8	mA
I ₋	Negative			-7.2	-7.8	mA
P _D	Power dissipation	±5 V, I _{REF} = 1.0 mA +5 V, -15 V, I _{REF} = 2.0 mA ±15 V, I _{REF} = 2.0 mA		37 122 156	48 136 174	mW mW mW

8-bit high-speed multiplying D/A converter

DAC-08 Series

AC ELECTRICAL CHARACTERISTICS

SYMBOL	PARAMETER	TEST CONDITIONS	DAC-08C			DAC-08E			DAC-08H			UNIT
			Min	Typ	Max	Min	Typ	Max	Min	Typ	Max	
t_s	Settling time	To $\pm 1/2$ LSB, all bits switched on or off, $T_{amb} = 25\text{ }^\circ\text{C}$		70	135		70	135		70	135	ns
t_{PLH}	Low-to-High	$T_{amb} = 25\text{ }^\circ\text{C}$, each bit.										ns
t_{PHL}	High-to-Low		All bits switched	35	60	35	60	35	60			

TEST CIRCUITS

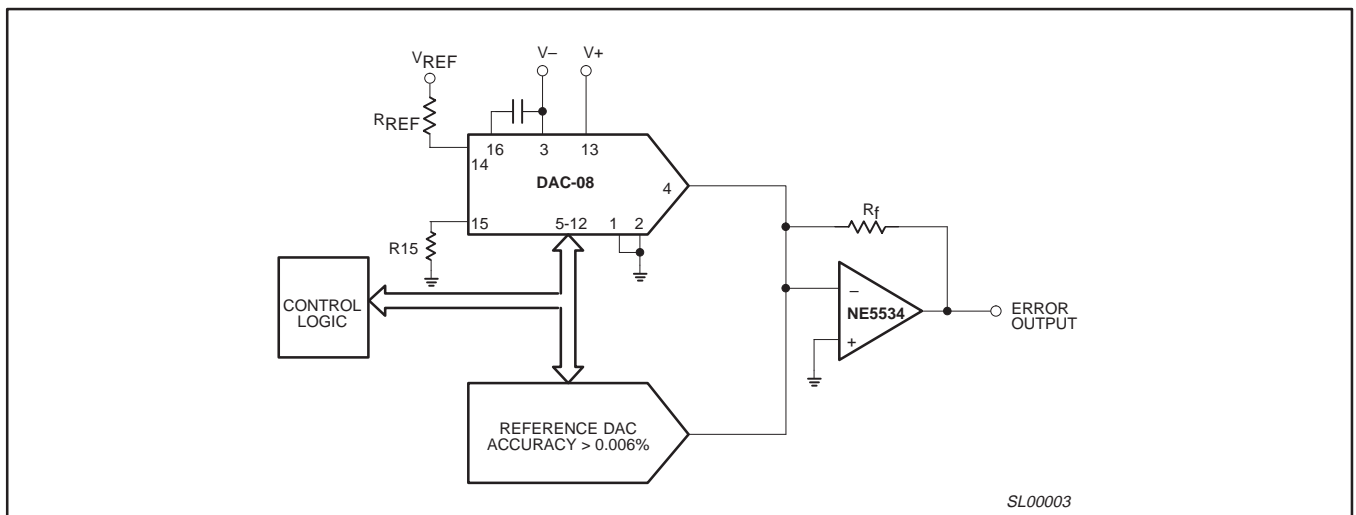

Figure 3. Relative Accuracy Test Circuit

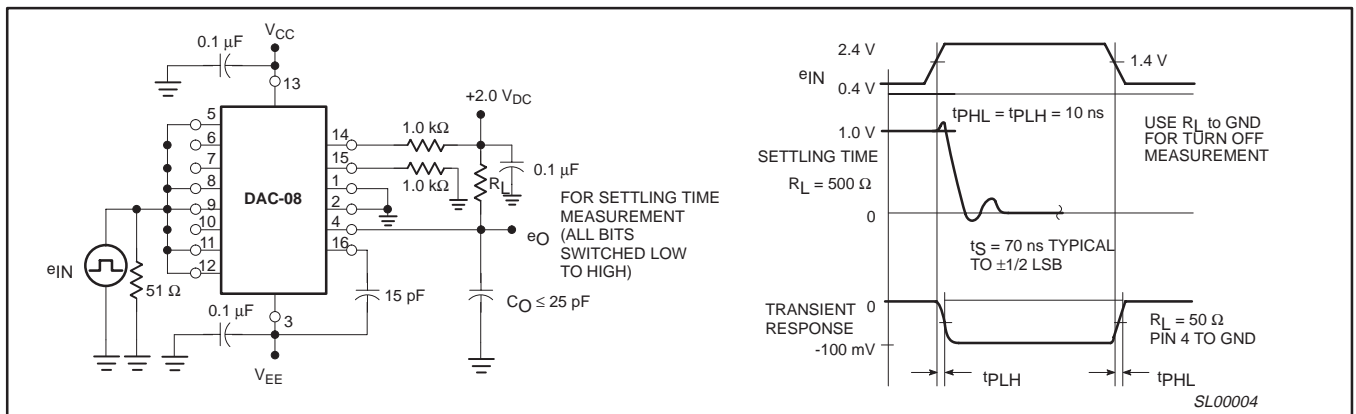

Figure 4. Transient Response and Settling Time

8-bit high-speed multiplying D/A converter

DAC-08 Series

TEST CIRCUITS (Continued)

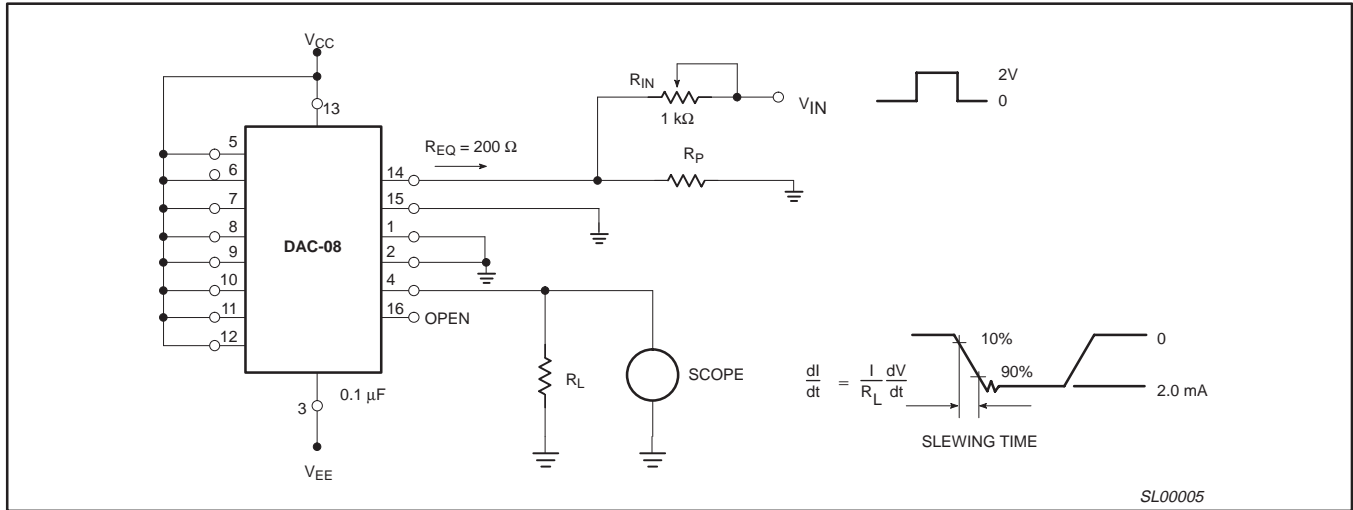

Figure 5. Reference Current Slew Rate Measurement

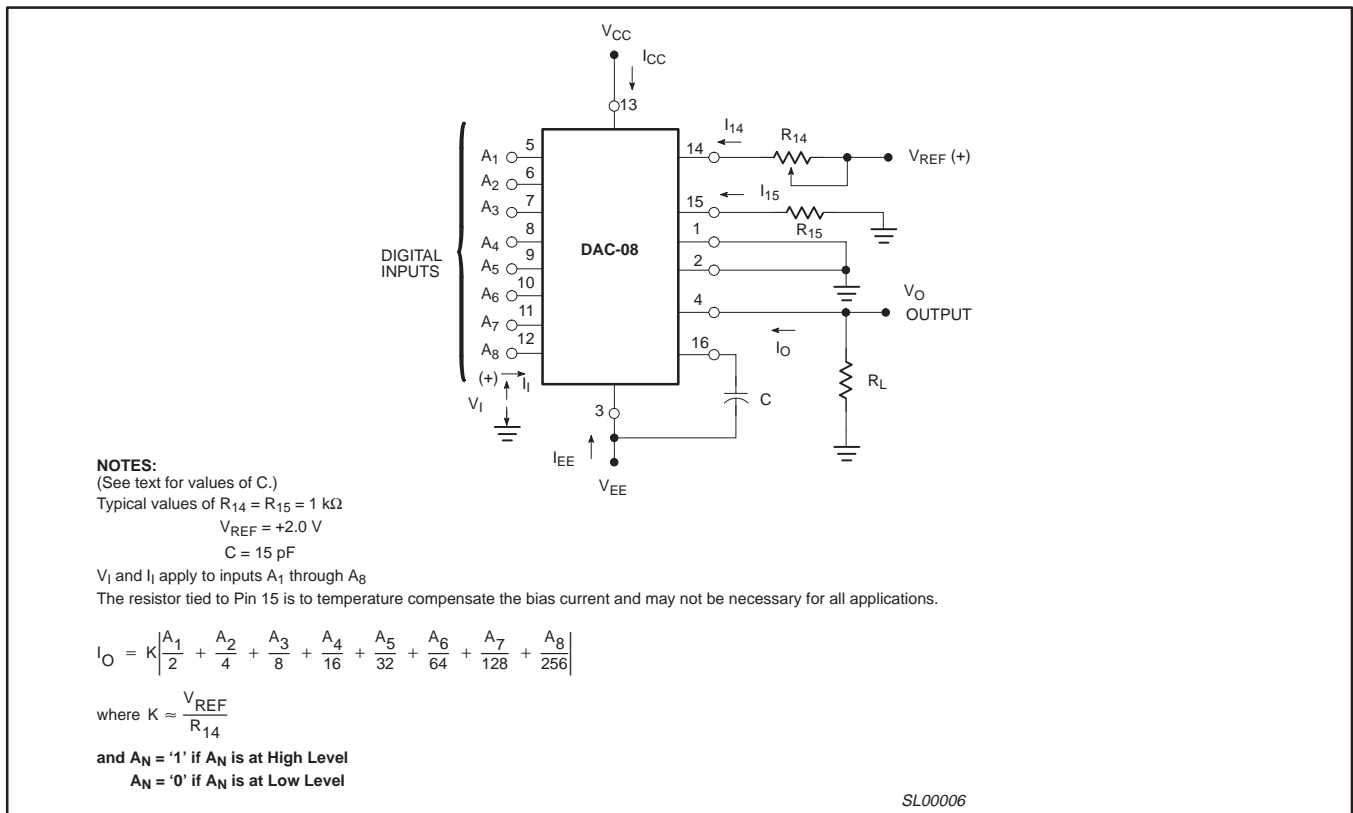

Figure 6. Notation Definitions

8-bit high-speed multiplying D/A converter

DAC-08 Series

TYPICAL PERFORMANCE CHARACTERISTICS

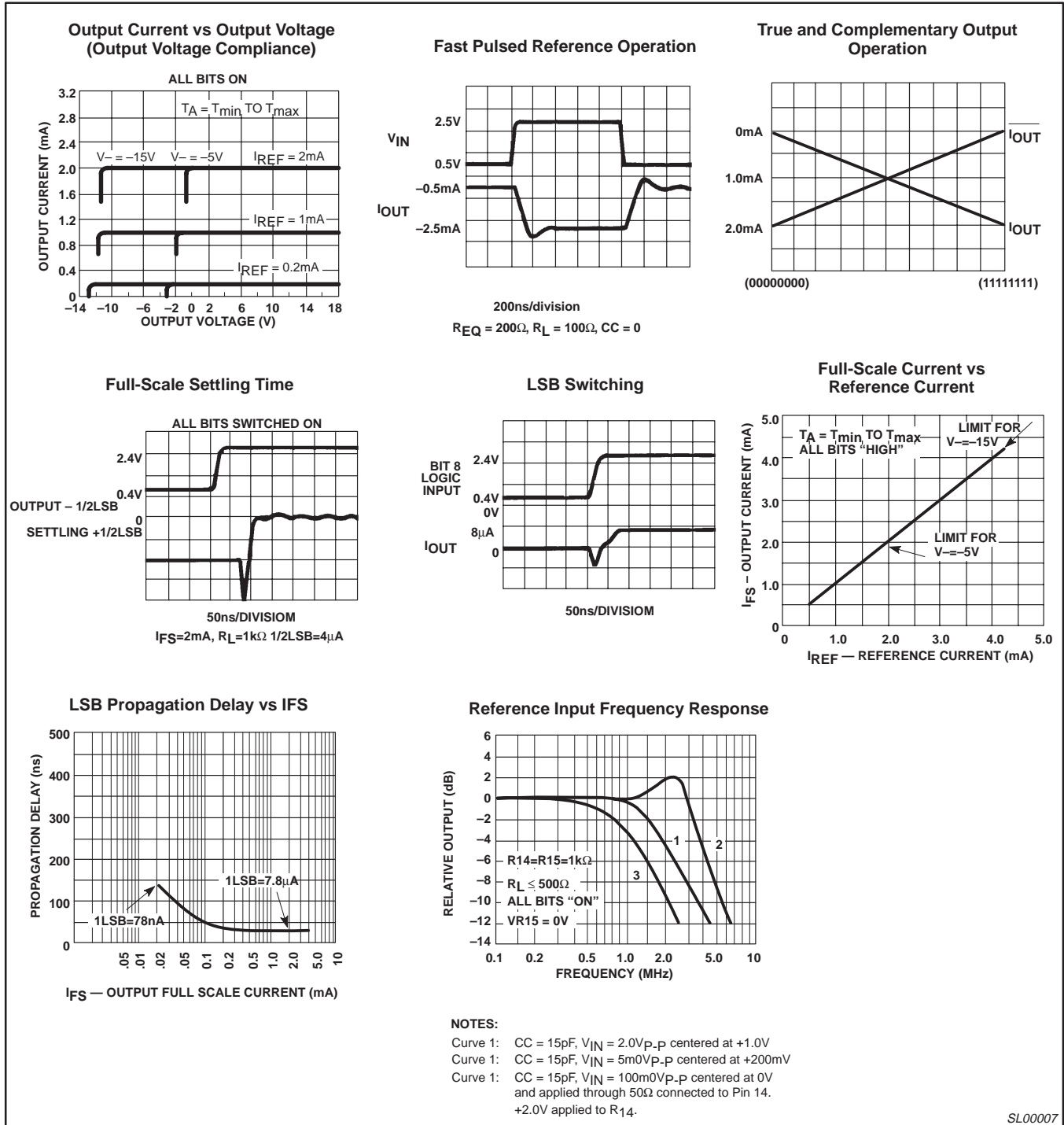

Figure 7. Typical Performance Characteristics

8-bit high-speed multiplying D/A converter

DAC-08 Series

TYPICAL PERFORMANCE CHARACTERISTICS (Continued)

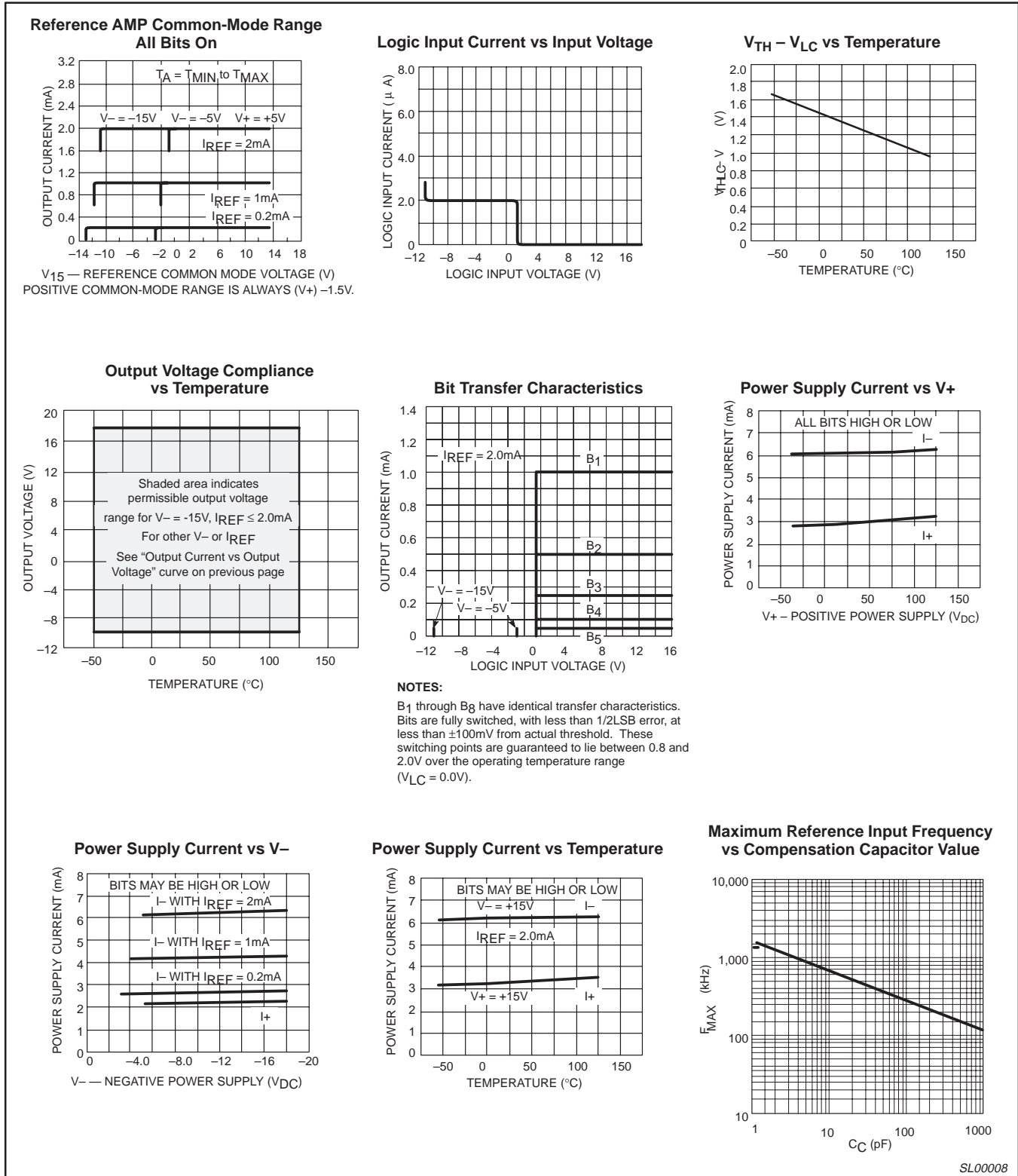

Figure 8. Typical Performance Characteristics (cont.)

SL00008

8-bit high-speed multiplying D/A converter

DAC-08 Series

TYPICAL APPLICATION

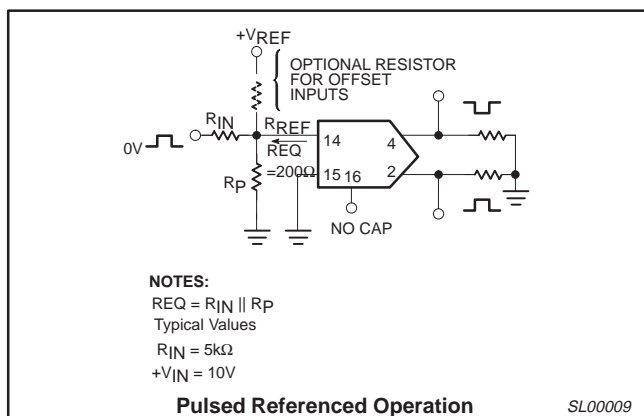

Figure 9. Typical Application

FUNCTIONAL DESCRIPTION

Reference Amplifier Drive and Compensation

The reference amplifier input current must always flow into Pin 14 regardless of the setup method or reference supply voltage polarity.

Connections for a positive reference voltage are shown in Figure 3. The reference voltage source supplies the full reference current. For bipolar reference signals, as in the multiplying mode, R_{15} can be tied to a negative voltage corresponding to the minimum input level. R_{15} may be eliminated with only a small sacrifice in accuracy and temperature drift.

The compensation capacitor value must be increased as R_{14} value is increased. This is in order to maintain proper phase margin. For R_{14} values of 1.0, 2.5, and 5.0 k Ω , minimum capacitor values are 15, 37, and 75 pF, respectively. The capacitor may be tied to either V_{EE} or ground, but using V_{EE} increases negative supply rejection. (Fluctuations in the negative supply have more effect on accuracy than do any changes in the positive supply.)

A negative reference voltage may be used if R_{14} is grounded and the reference voltage is applied to R_{15} as shown. A high input impedance is the main advantage of this method. The negative reference voltage must be at least 3.0 V above the V_{EE} supply. Bipolar input signals may be handled by connecting R_{14} to a positive reference voltage equal to the peak positive input level at Pin 15.

When using a DC reference voltage, capacitive bypass to ground is recommended. The 5.0 V logic supply is not recommended as a reference voltage, but if a well regulated 5.0V supply which drives logic is to be used as the reference, R_{14} should be formed of two series resistors with the junction of the two resistors bypassed with 0.1 μ F to ground. For reference voltages greater than 5.0 V, a clamp diode is recommended between Pin 14 and ground.

If Pin 14 is driven by a high impedance such as a transistor current source, none of the above compensation methods applies and the amplifier must be heavily compensated, decreasing the overall bandwidth.

Output Voltage Range

The voltage at Pin 4 must always be at least 4.5 V more positive than the voltage of the negative supply (Pin 3) when the reference current is 2 mA or less, and at least 8 V more positive than the negative supply when the reference current is between 2 mA and 4 mA. This is necessary to avoid saturation of the output transistors, which would cause serious accuracy degradation.

Output Current Range

Any time the full-scale current exceeds 2 mA, the negative supply must be at least 8 V more negative than the output voltage. This is due to the increased internal voltage drops between the negative supply and the outputs with higher reference currents.

Accuracy

Absolute accuracy is the measure of each output current level with respect to its intended value, and is dependent upon relative accuracy, full-scale accuracy and full-scale current drift. Relative accuracy is the measure of each output current level as a fraction of the full-scale current after zero-scale current has been nulled out. The relative accuracy of the DAC-08 series is essentially constant over the operating temperature range due to the excellent temperature tracking of the monolithic resistor ladder. The reference current may drift with temperature, causing a change in the absolute accuracy of output current. However, the DAC-08 series has a very low full-scale current drift over the operating temperature range.

The DAC-08 series is guaranteed accurate to within \pm LSB at +25 $^{\circ}$ C at a full-scale output current of 1.992 mA. The relative accuracy test circuit is shown in Figure 3. The 12-bit converter is calibrated to a full-scale output current of 1.99219 mA, then the DAC-08 full-scale current is trimmed to the same value with R_{14} so that a zero value appears at the error amplifier output. The counter is activated and the error band may be displayed on the oscilloscope, detected by comparators, or stored in a peak detector.

Two 8-bit D-to-A converters may not be used to construct a 16-bit accurate D-to-A converter. 16-bit accuracy implies a total of \pm part in 65,536, or $\pm 0.00076\%$, which is much more accurate than the $\pm 0.19\%$ specification of the DAC-08 series.

Monotonicity

A monotonic converter is one which always provides analog output greater than or equal to the preceding value for a corresponding increment in the digital input code. The DAC-08 series is monotonic for all values of reference current above 0.5 mA. The recommended range for operation is a DC reference current between 0.5 mA and 4.0 mA.

Settling Time

The worst-case switching condition occurs when all bits are switched on, which corresponds to a low-to-high transition for all input bits. This time is typically 70 ns for settling to within LSB for 8-bit accuracy. This time applies when $R_L < 500 \Omega$ and $C_O < 25$ pF. The slowest single switch is the least significant bit, which typically turns on and settles in 65 ns. In applications where the DAC functions in a positive-going ramp mode, the worst-case condition does not occur and settling times less than 70 ns may be realized.

Extra care must be taken in board layout since this usually is the dominant factor in satisfactory test results when measuring settling time. Short leads, 100 μ F supply bypassing for low frequencies, minimum scope lead length, and avoidance of ground loops are all mandatory.

8-bit high-speed multiplying D/A converter

DAC-08 Series

SETTLING TIME AND PROPAGATION DELAY

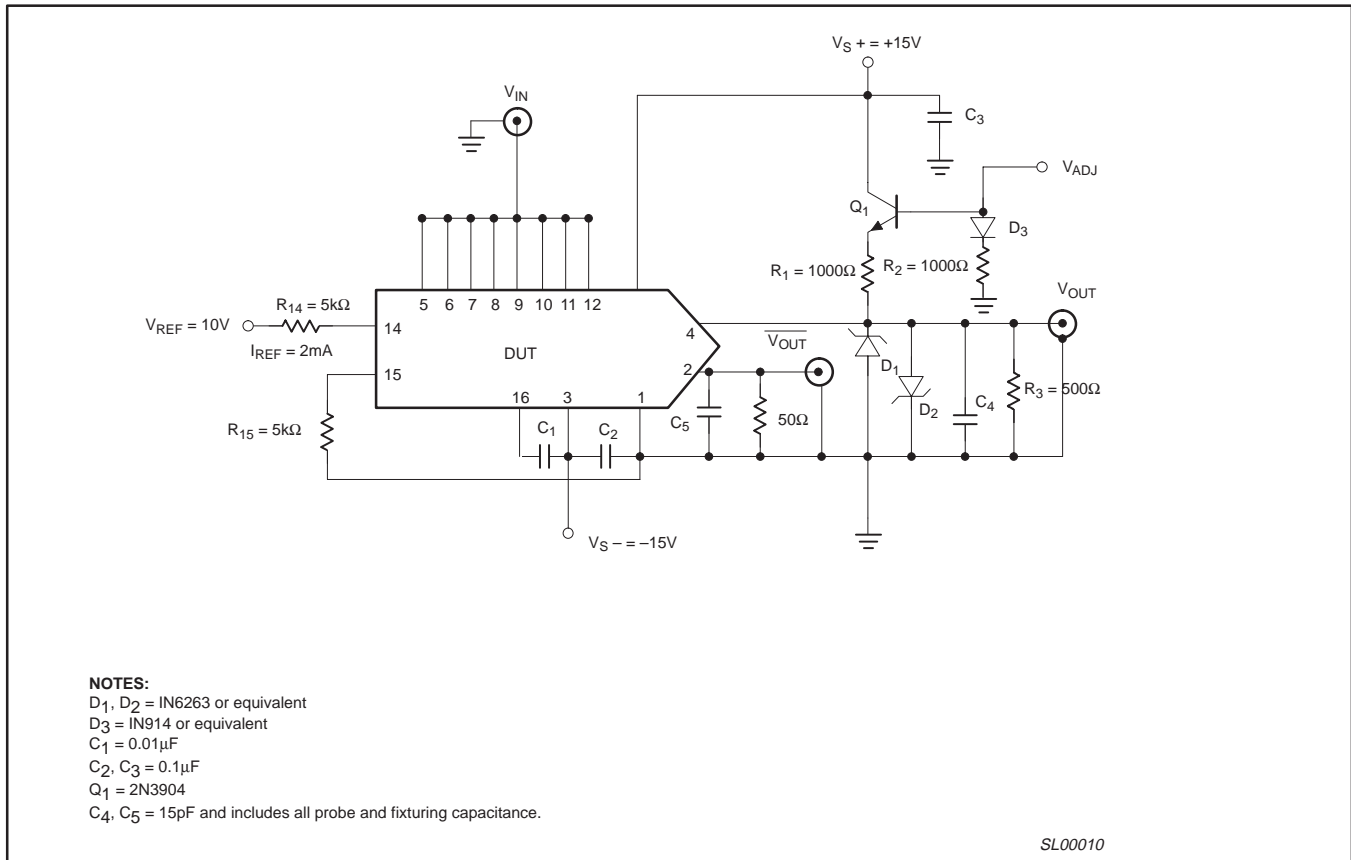

Figure 10. Settling Time and Propagation Delay

BASIC DAC-08 CONFIGURATION

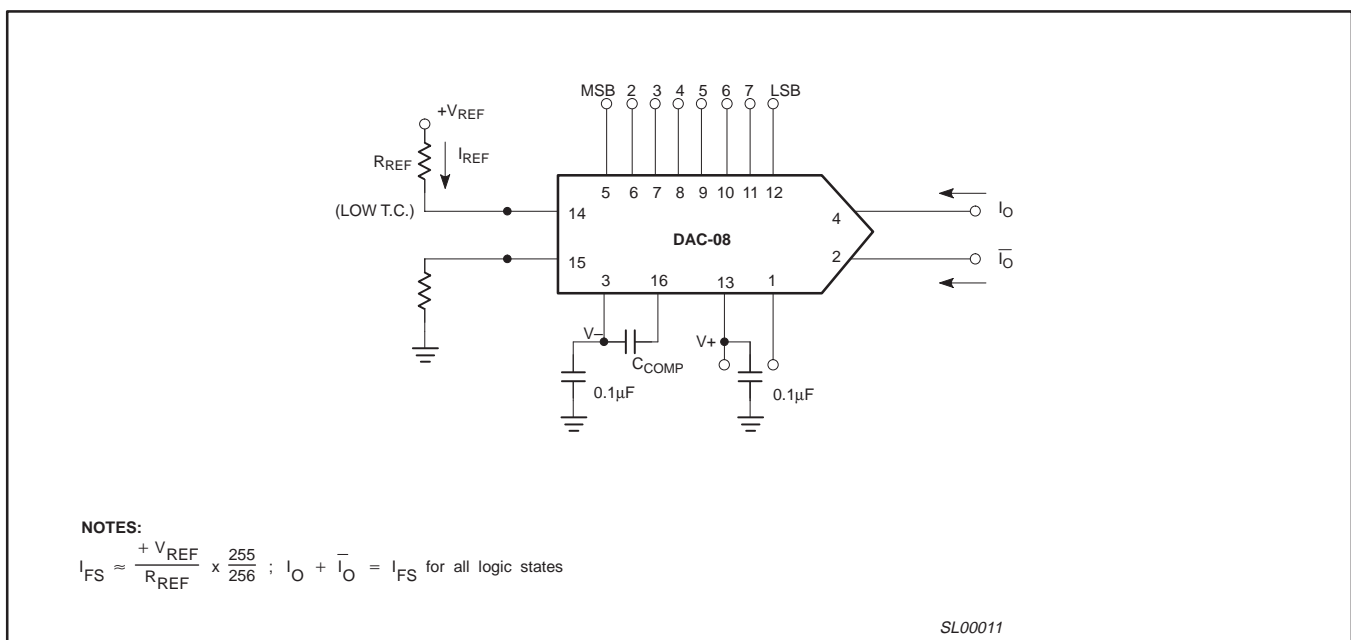

Figure 11. Basic DAC-08 Configuration

8-bit high-speed multiplying D/A converter

DAC-08 Series

RECOMMENDED FULL-SCALE AND ZERO-SCALE ADJUST

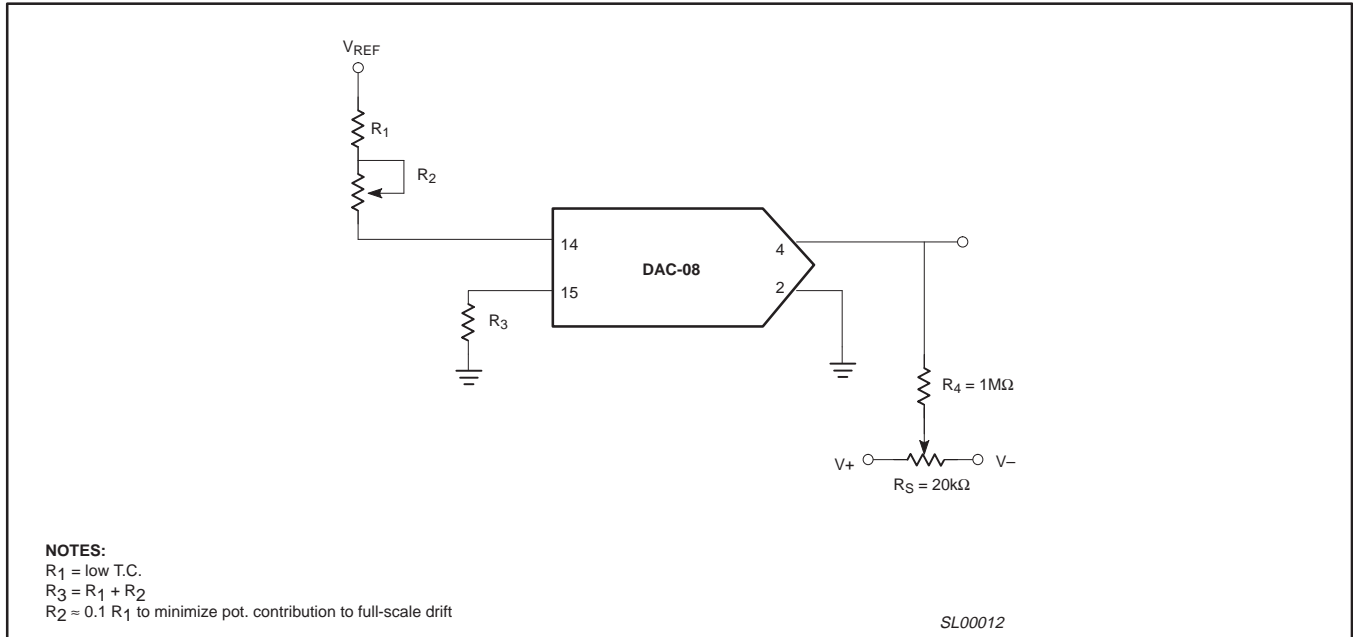

Figure 12. Recommended Full-Scale and Zero-Scale Adjust

UNIPOLAR VOLTAGE OUTPUT FOR LOW IMPEDANCE OUTPUT

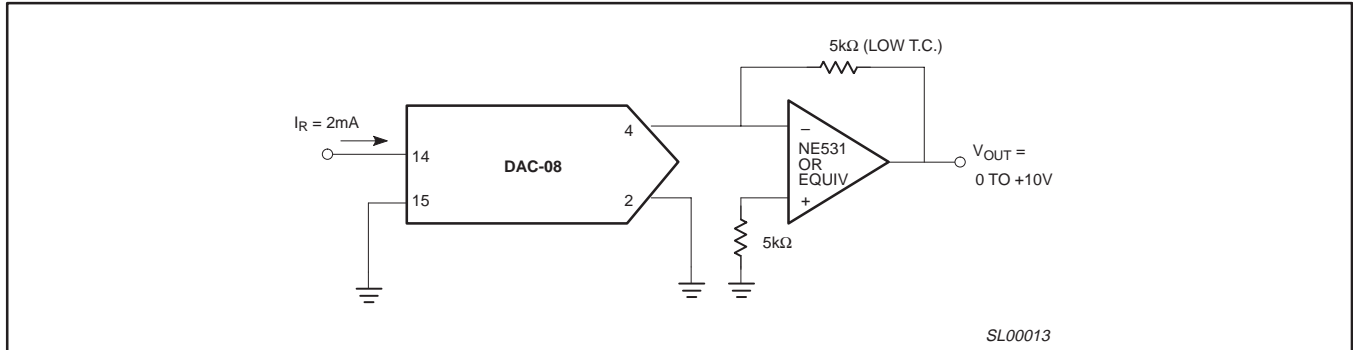

Figure 13. Unipolar Voltage Output for Low Impedance Output

8-bit high-speed multiplying D/A converter

DAC-08 Series

UNIPOLAR VOLTAGE OUTPUT FOR HIGH IMPEDANCE OUTPUT

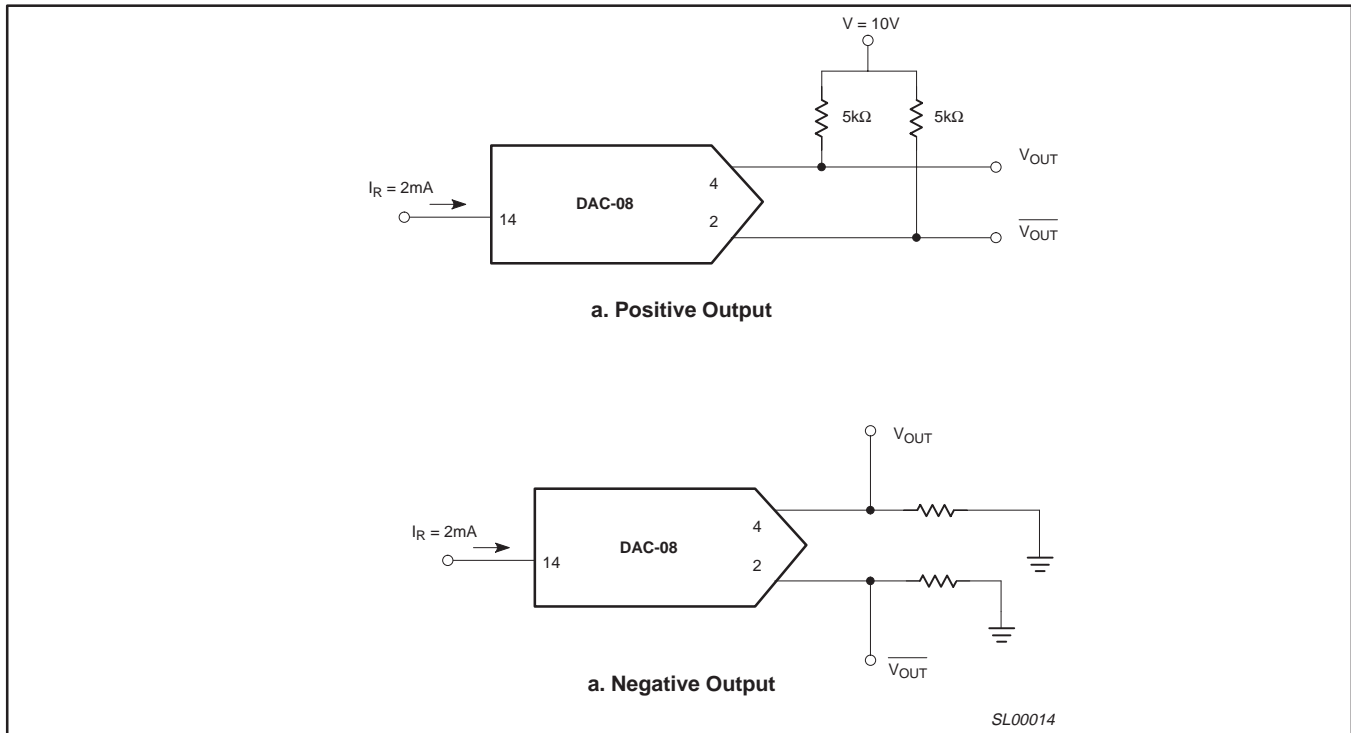

Figure 14. Unipolar Voltage Output for High Impedance Output

BASIC BIPOLAR OUTPUT OPERATION (OFFSET BINARY)

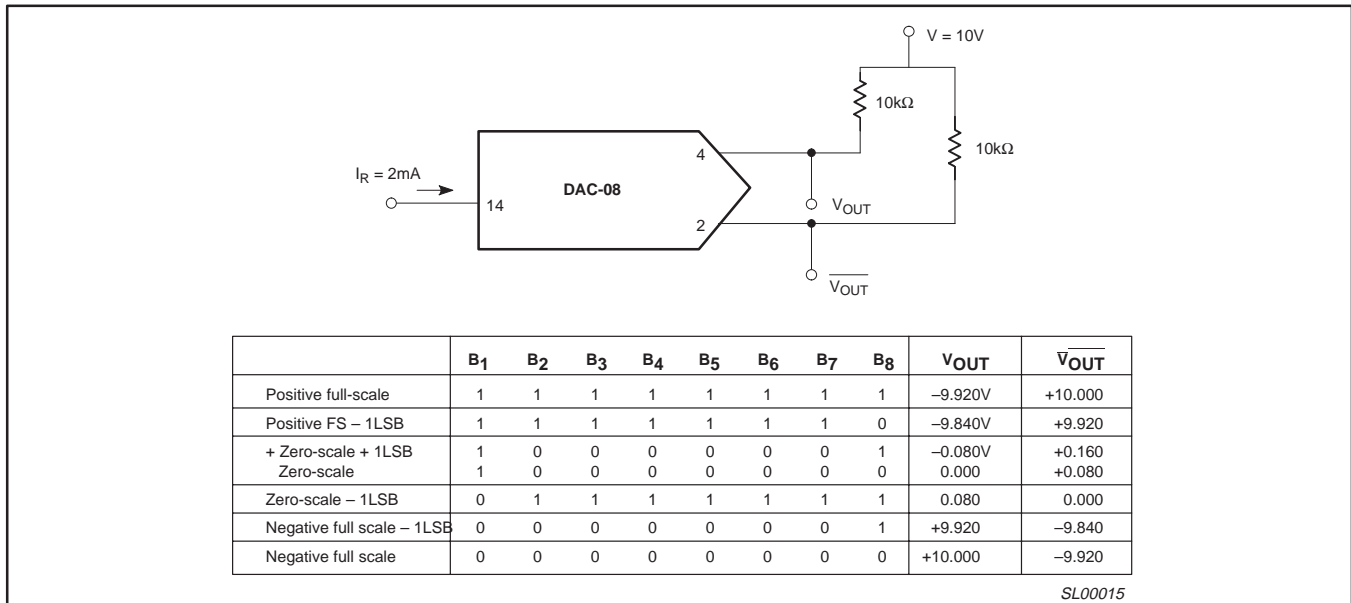

Figure 15. Basic Bipolar Output Operation (Offset Binary)

8-bit high-speed multiplying D/A converter

DAC-08 Series

DIP16: plastic dual in-line package; 16 leads (300 mil)

SOT38-4

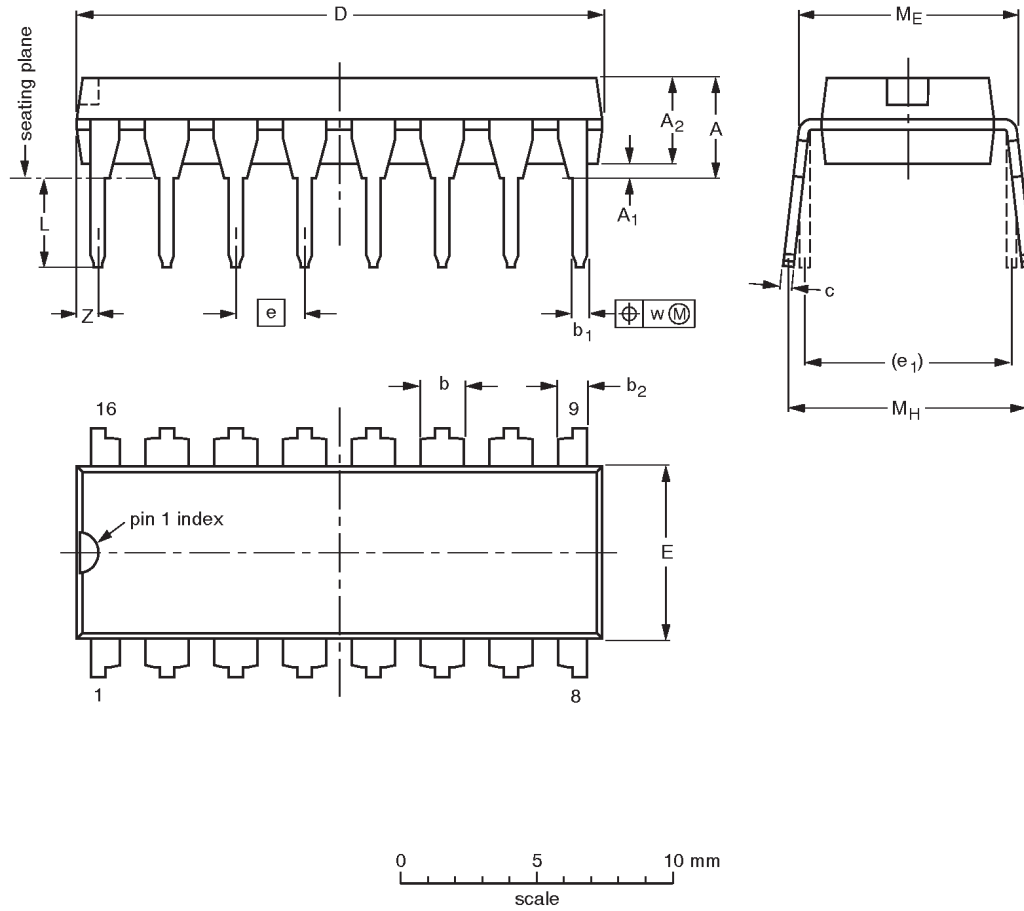

DIMENSIONS (inch dimensions are derived from the original mm dimensions)

UNIT	A max.	A ₁ min.	A ₂ max.	b	b ₁	b ₂	c	D ⁽¹⁾	E ⁽¹⁾	e	e ₁	L	M _E	M _H	w	z ⁽¹⁾ max.
mm	4.2	0.51	3.2	1.73 1.30	0.53 0.38	1.25 0.85	0.36 0.23	19.50 18.55	6.48 6.20	2.54	7.62	3.60 3.05	8.25 7.80	10.0 8.3	0.254	0.76
inches	0.17	0.020	0.13	0.068 0.051	0.021 0.015	0.049 0.033	0.014 0.009	0.77 0.73	0.26 0.24	0.10	0.30	0.14 0.12	0.32 0.31	0.39 0.33	0.01	0.030

Note

1. Plastic or metal protrusions of 0.25 mm maximum per side are not included.

OUTLINE VERSION	REFERENCES				EUROPEAN PROJECTION	ISSUE DATE
	IEC	JEDEC	EIAJ			
SOT38-4						92-11-17 95-01-14

8-bit high-speed multiplying D/A converter

DAC-08 Series

SO16: plastic small outline package; 16 leads; body width 3.9 mm

SOT109-1

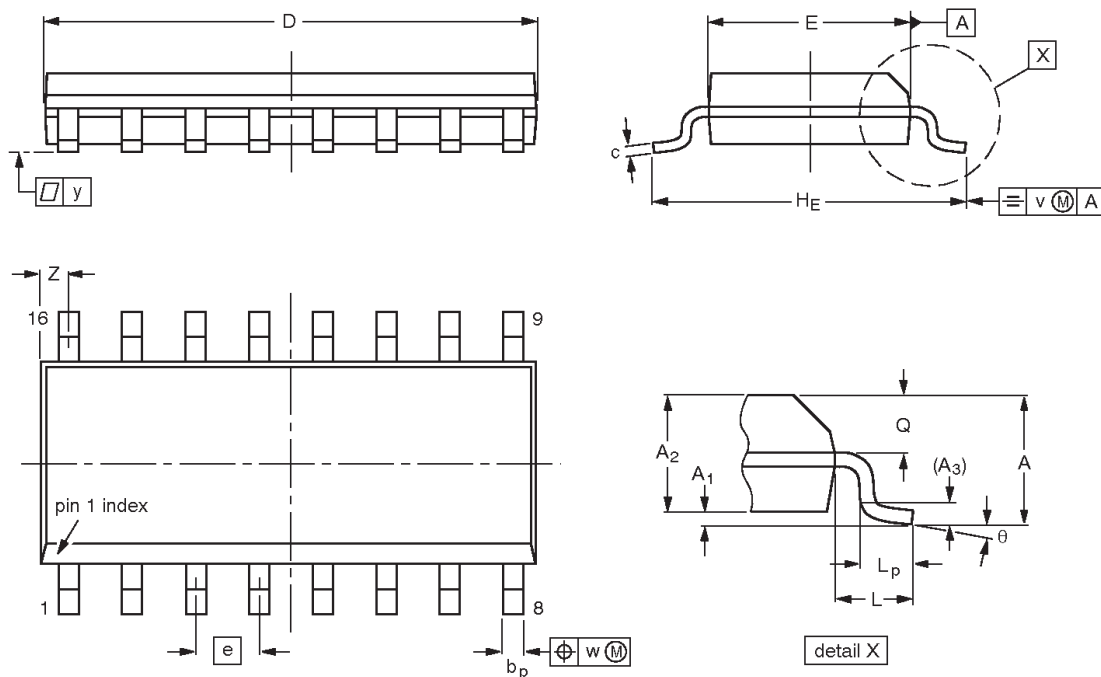

DIMENSIONS (inch dimensions are derived from the original mm dimensions)

UNIT	A max.	A ₁	A ₂	A ₃	b _p	c	D ⁽¹⁾	E ⁽¹⁾	e	H _E	L	L _p	Q	v	w	y	Z ⁽¹⁾	θ
mm	1.75	0.25 0.10	1.45 1.25	0.25	0.49 0.36	0.25 0.19	10.0 9.8	4.0 3.8	1.27	6.2 5.8	1.05	1.0 0.4	0.7 0.6	0.25	0.25	0.1	0.7 0.3	8° 0°
inches	0.069	0.010 0.004	0.057 0.049	0.01	0.019 0.014	0.0100 0.0075	0.39 0.38	0.16 0.15	0.050	0.244 0.228	0.041	0.039 0.016	0.028 0.020	0.01	0.01	0.004	0.028 0.012	

Note

1. Plastic or metal protrusions of 0.15 mm maximum per side are not included.

OUTLINE VERSION	REFERENCES				EUROPEAN PROJECTION	ISSUE DATE
	IEC	JEDEC	EIAJ			
SOT109-1	076E07	MS-012				97-05-22- 99-12-27

8-bit high-speed multiplying D/A converter

DAC-08 Series

Data sheet status

Data sheet status ^[1]	Product status ^[2]	Definitions
Objective data	Development	This data sheet contains data from the objective specification for product development. Philips Semiconductors reserves the right to change the specification in any manner without notice.
Preliminary data	Qualification	This data sheet contains data from the preliminary specification. Supplementary data will be published at a later date. Philips Semiconductors reserves the right to change the specification without notice, in order to improve the design and supply the best possible product.
Product data	Production	This data sheet contains data from the product specification. Philips Semiconductors reserves the right to make changes at any time in order to improve the design, manufacturing and supply. Changes will be communicated according to the Customer Product/Process Change Notification (CPCN) procedure SNW-SQ-650A.

[1] Please consult the most recently issued data sheet before initiating or completing a design.

[2] The product status of the device(s) described in this data sheet may have changed since this data sheet was published. The latest information is available on the Internet at URL <http://www.semiconductors.philips.com>.

Definitions

Short-form specification — The data in a short-form specification is extracted from a full data sheet with the same type number and title. For detailed information see the relevant data sheet or data handbook.

Limiting values definition — Limiting values given are in accordance with the Absolute Maximum Rating System (IEC 60134). Stress above one or more of the limiting values may cause permanent damage to the device. These are stress ratings only and operation of the device at these or at any other conditions above those given in the Characteristics sections of the specification is not implied. Exposure to limiting values for extended periods may affect device reliability.

Application information — Applications that are described herein for any of these products are for illustrative purposes only. Philips Semiconductors make no representation or warranty that such applications will be suitable for the specified use without further testing or modification.

Disclaimers

Life support — These products are not designed for use in life support appliances, devices or systems where malfunction of these products can reasonably be expected to result in personal injury. Philips Semiconductors customers using or selling these products for use in such applications do so at their own risk and agree to fully indemnify Philips Semiconductors for any damages resulting from such application.

Right to make changes — Philips Semiconductors reserves the right to make changes, without notice, in the products, including circuits, standard cells, and/or software, described or contained herein in order to improve design and/or performance. Philips Semiconductors assumes no responsibility or liability for the use of any of these products, conveys no license or title under any patent, copyright, or mask work right to these products, and makes no representations or warranties that these products are free from patent, copyright, or mask work right infringement, unless otherwise specified.

Contact information

For additional information please visit
<http://www.semiconductors.philips.com>. Fax: +31 40 27 24825

© Koninklijke Philips Electronics N.V. 2001
 All rights reserved. Printed in U.S.A.

Date of release: 10-01

For sales offices addresses send e-mail to:
sales.addresses@www.semiconductors.philips.com

Document order number:

9397 750 08922

Let's make things better.



LittleDiode supplies new, hard to find or obsolete electronic components and semiconductors all over the world.

With over two million different components listed you are sure to find the part you need.

Feel free to visit us today at our online store:

LittleDiode.com

Looking forward to providing you with the best possible service.