

Features

- **High speed**
— 20 ns
- **Low active power**
— 605 mW
- **Low standby power**
— 110 mW
- **CMOS for optimum speed/power**
- **Easy memory expansion with \overline{CE}_1 , CE_2 , and \overline{OE} features**
- **TTL-compatible inputs and outputs**
- **Automatic power-down when deselected**

Functional Description

The CY7C186 is a high-performance CMOS static RAM organized as 8192 words by 8 bits. Easy memory expansion is

provided by an active LOW chip enable (\overline{CE}_1), an active HIGH chip enable (CE_2), and active LOW output enable (\overline{OE}) and three-state drivers. The device has an automatic power-down feature (\overline{CE}_1), reducing the power consumption by over 80% when deselected. The CY7C186 is in a 600-mil-wide PDIP package and a 32-pin TSOP (std. pinout).

An active LOW write enable signal (\overline{WE}) controls the writing/reading operation of the memory. When \overline{CE}_1 and \overline{WE} inputs are both LOW and CE_2 is HIGH, data on the eight data input/output pins (I/O_0 through I/O_7) is written into the memory location addressed by the address present on the address pins (A_0 through A_{12}). Reading the device is accomplished by selecting the device and enabling the outputs, \overline{CE}_1 and \overline{OE} active LOW, CE_2 active HIGH, while \overline{WE} remains inactive or HIGH. Under these conditions, the contents of the location addressed by the information on address pins are present on the eight data input/output pins.

The input/output pins remain in a high-impedance state unless the chip is selected, outputs are enabled, and write enable (\overline{WE}) is HIGH. A die coat is used to insure alpha immunity.

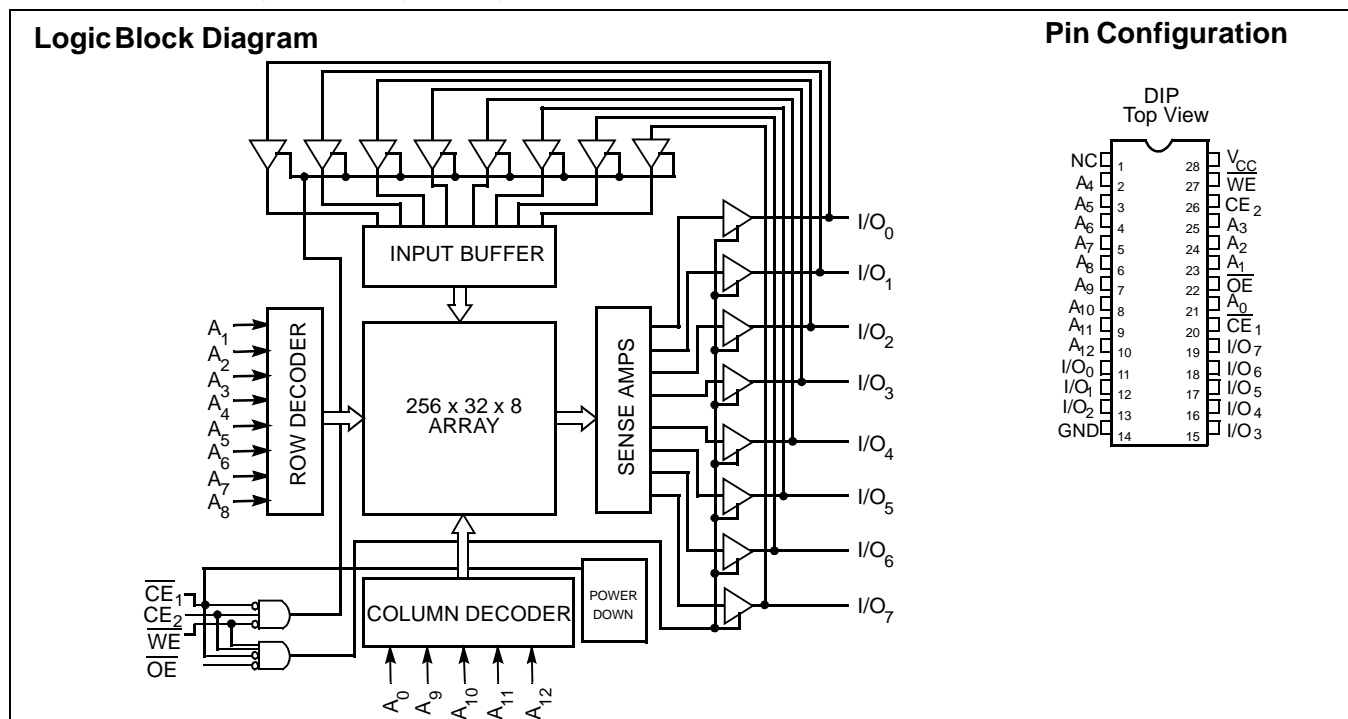
Selection Guide^[1]

	7C186-20	7C186-25	7C186-35
Maximum Access Time (ns)	20	25	35
Maximum Operating Current (mA)	110	100	100
Maximum Standby Current (mA)	20/15	20/15	20/15

Notes:

1. For military specifications, see the CY7C186A datasheet.

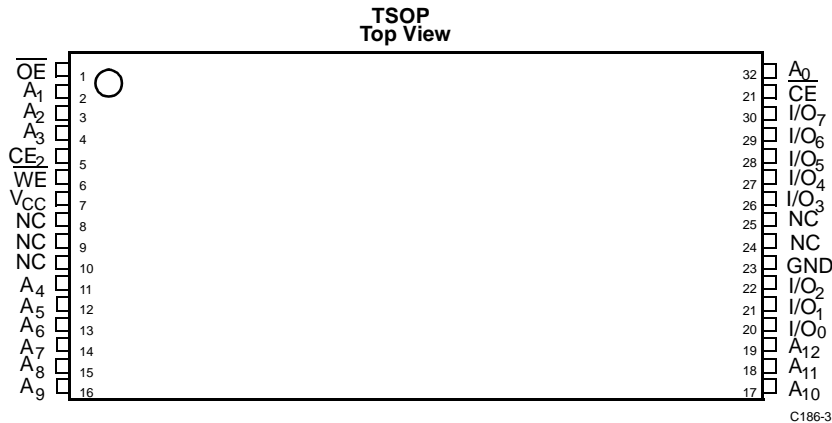
Pin Configurations (continued)

Maximum Ratings

(Above which the useful life may be impaired. For user guidelines, not tested.)

Storage Temperature -65°C to +150°C

Ambient Temperature with Power Applied..... -55°C to +125°C

Supply Voltage to Ground Potential..... -0.5V to +7.0V

DC Voltage Applied to Outputs in High Z State^[2]..... -0.5V to +7.0V

DC Input Voltage^[2] -0.5V to +7.0V

Output Current into Outputs (LOW)..... 20 mA

Static Discharge Voltage >2001V (per MIL-STD-883, Method 3015)

Latch-Up Current..... >200 mA

Operating Range

Range	Ambient Temperature	V _{CC}
Commercial	0°C to +70°C	5V ± 10%

Electrical Characteristics Over the Operating Range

Parameter	Description	Test Conditions	7C186-20		7C186-25,35		Unit
			Min.	Max.	Min.	Max.	
V _{OH}	Output HIGH Voltage	V _{CC} = Min., I _{OH} = -4.0 mA	2.4		2.4		V
V _{OL}	Output LOW Voltage	V _{CC} = Min., I _{OL} = 8.0 mA		0.4		0.4	V
V _{IH}	Input HIGH Voltage		2.2	V _{CC}	2.2	V _{CC}	V
V _{IL}	Input LOW Voltage ^[2]		-0.5	0.8	-0.5	0.8	V
I _{Ix}	Input Load Current	GND ≤ V _I ≤ V _{CC}	-5	+5	-5	+5	μA
I _{OZ}	Output Leakage Current	GND ≤ V _I ≤ V _{CC} , Output Disabled	-5	+5	-5	+5	μA
I _{OS}	Output Short Circuit Current ^[3]	V _{CC} = Max., V _{OUT} = GND		-300		-300	mA
I _{CC}	V _{CC} Operating Supply Current	V _{CC} = Max., I _{OUT} = 0 mA		110		100	mA
I _{SB1}	Automatic \overline{CE}_1 Power-Down Current	Max. V _{CC} , $\overline{CE}_1 \geq V_{IH}$, Min. Duty Cycle=100%		20		20	mA
I _{SB2}	Automatic \overline{CE}_1 Power-Down Current	Max. V _{CC} , $\overline{CE}_1 \geq V_{CC} - 0.3V$, V _{IN} ≥ V _{CC} - 0.3V or V _{IN} ≤ 0.3V		15		15	mA

Capacitance^[4]

Parameter	Description	Test Conditions	Max.	Unit
C _{IN}	Input Capacitance	T _A = 25°C, f = 1 MHz, V _{CC} = 5.0V	7	pF
C _{OUT}	Output Capacitance		7	pF

Notes:

2. Minimum voltage is equal to -3.0V for pulse durations less than 30 ns.
3. Not more than 1 output should be shorted at one time. Duration of the short circuit should not exceed 30 seconds.
4. Tested initially and after any design or process changes that may affect these parameters.

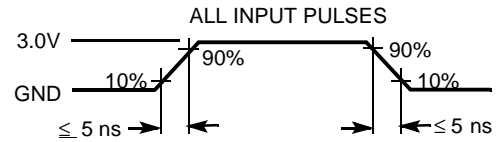
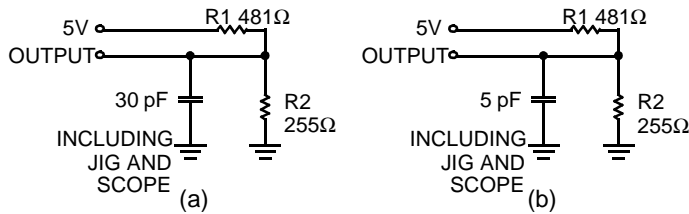
AC Test Loads and Waveforms

Equivalent to: THEVENIN EQUIVALENT

Switching Characteristics Over the Operating Range^[5]

Parameter	Description	7C186-20		7C186-25		7C186-35		Unit
		Min.	Max.	Min.	Max.	Min.	Max.	
READ CYCLE								
t_{RC}	Read Cycle Time	20		25		35		ns
t_{AA}	Address to Data Valid		20		25		35	ns
t_{OHA}	Data Hold from Address Change	5		5		5		ns
t_{ACE1}	\overline{CE}_1 LOW to Data Valid		20		25		35	ns
t_{ACE2}	CE_2 HIGH to Data Valid		20		25		35	ns
t_{DOE}	\overline{OE} LOW to Data Valid		9		12		15	ns
t_{LZOE}	\overline{OE} LOW to Low Z	3		3		3		ns
t_{HZOE}	\overline{OE} HIGH to High Z ^[6]		8		10		10	ns
t_{LZCE1}	\overline{CE}_1 LOW to Low Z ^[7]	5		5		5		ns
t_{LZCE2}	CE_2 HIGH to Low Z	3		3		3		ns
t_{HZCE}	\overline{CE}_1 HIGH to High Z ^[6, 7] CE_2 LOW to High Z		8		10		10	ns
t_{PU}	\overline{CE}_1 LOW to Power-Up	0		0		0		ns
t_{PD}	\overline{CE}_1 HIGH to Power-Down		20		20		20	ns
WRITE CYCLE ^[8]								
t_{WC}	Write Cycle Time	20		25		35		ns
t_{SCE1}	\overline{CE}_1 LOW to Write End	15		20		20		ns
t_{SCE2}	CE_2 HIGH to Write End	15		20		20		ns
t_{AW}	Address Set-Up to Write End	15		20		25		ns
t_{HA}	Address Hold from Write End	0		0		0		ns
t_{SA}	Address Set-Up to Write Start	0		0		0		ns
t_{PWE}	\overline{WE} Pulse Width	15		15		20		ns
t_{SD}	Data Set-Up to Write End	10		10		12		ns
t_{HD}	Data Hold from Write End	0		0		0		ns
t_{HZWE}	\overline{WE} LOW to High Z ^[6]		7		7		8	ns
t_{LZWE}	\overline{WE} HIGH to Low Z	5		5		5		ns

Notes:

- Test conditions assume signal transition time of 5 ns or less, timing reference levels of 1.5V, input pulse levels of 0 to 3.0V, and output loading of the specified I_{OL}/I_{OH} and 30-pF load capacitance.
- t_{HZOE} , t_{HZCE} , and t_{HZWE} are specified with $C_L = 5$ pF as in part (b) of AC Test Loads. Transition is measured ± 500 mV from steady-state voltage.
- At any given temperature and voltage condition, t_{HZCE} is less than t_{LZCE} for any given device.
- The internal write time of the memory is defined by the overlap of \overline{CE}_1 LOW, CE_2 HIGH, and \overline{WE} LOW. All signals must be active to initiate a write, and any signal can terminate a write by going inactive. The data input set-up and hold timing should be referenced to the trailing edge of the signal that terminates the write.

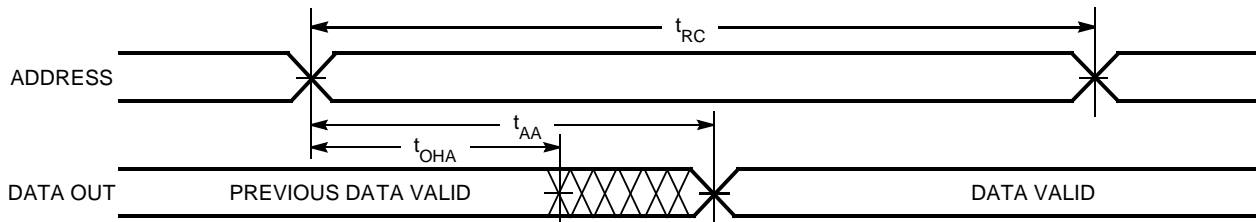
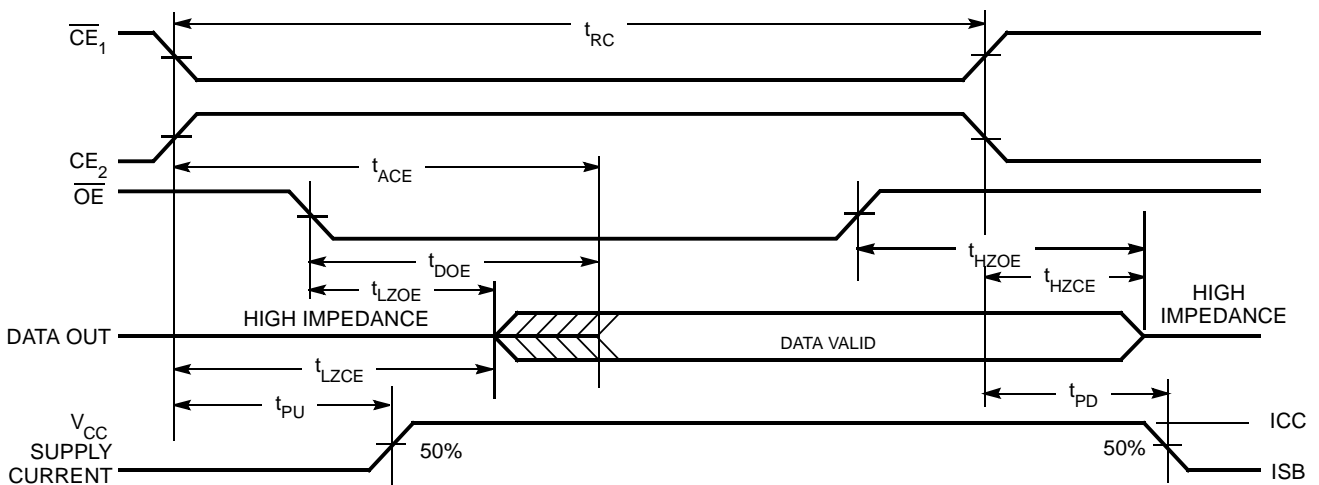
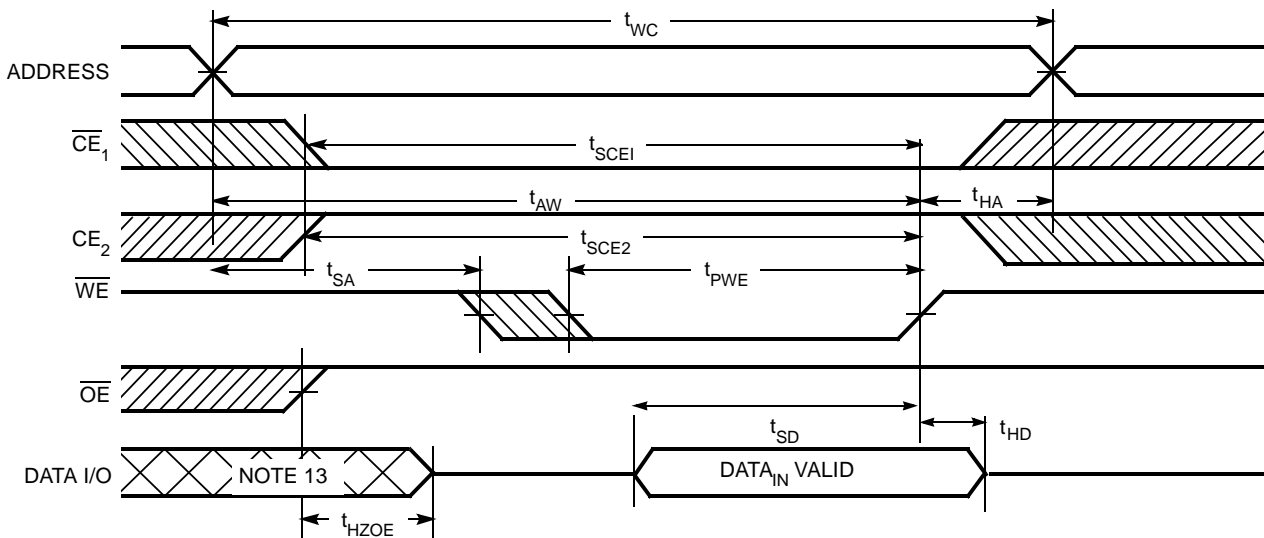
Switching Waveforms
Read Cycle No. 1^[9]

Read Cycle No. 2^[10, 11]

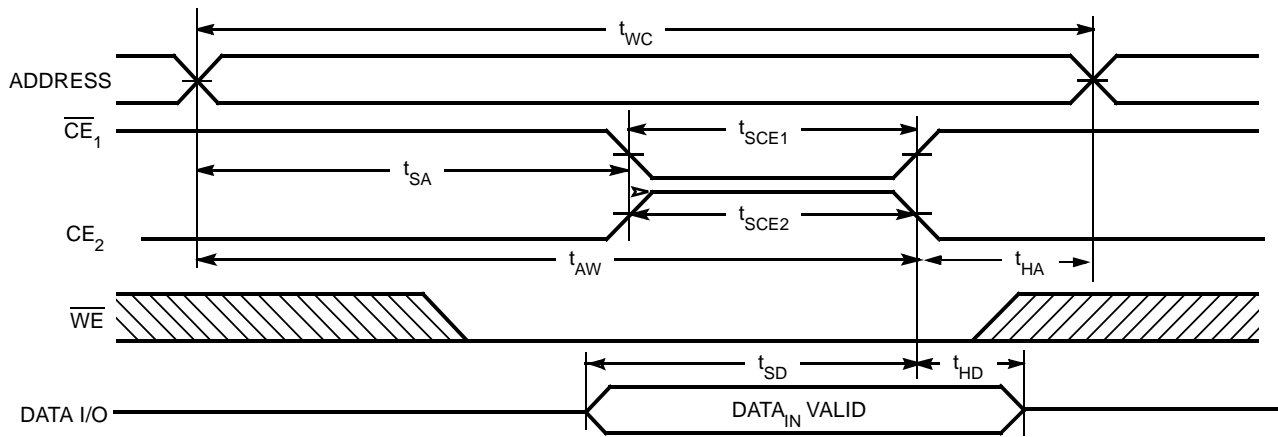
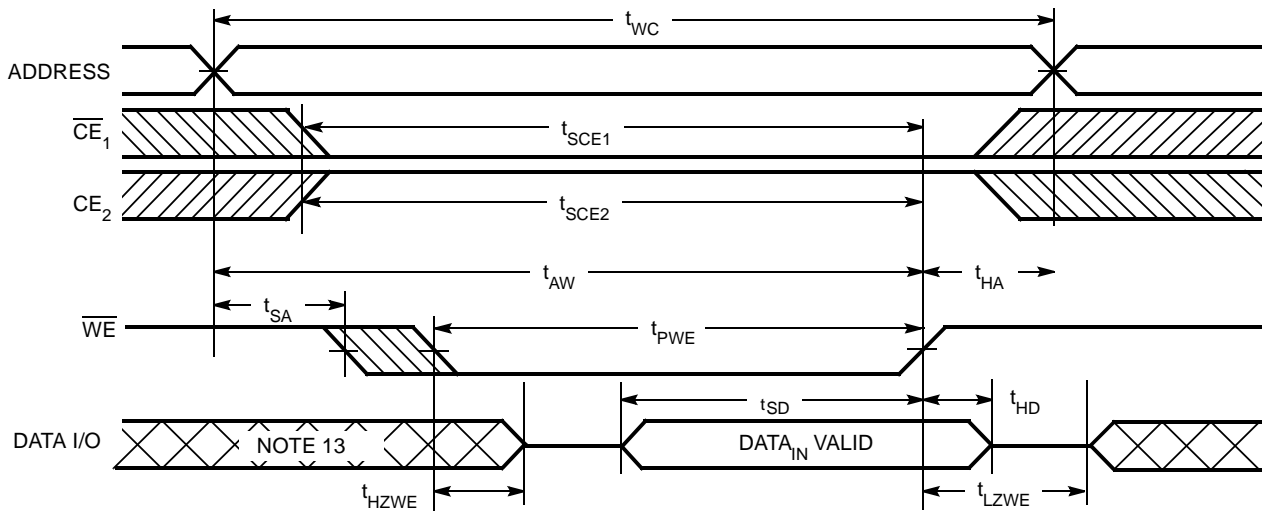
Write Cycle No. 1 (WE Controlled)^[11, 12]

Notes:

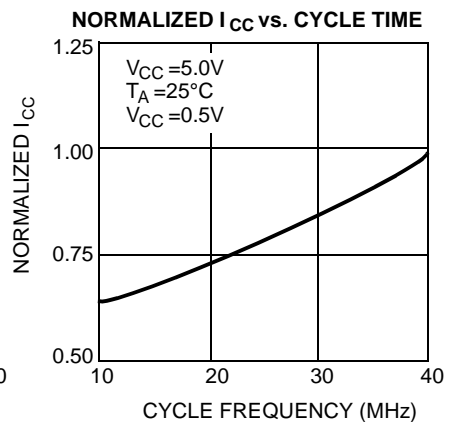
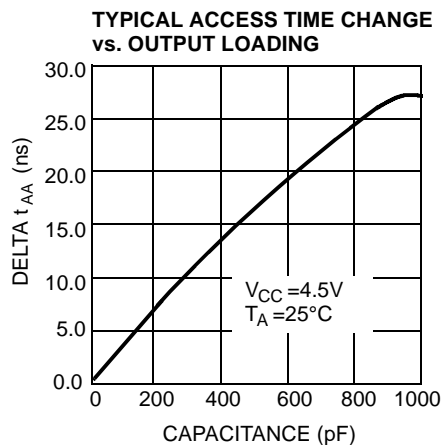
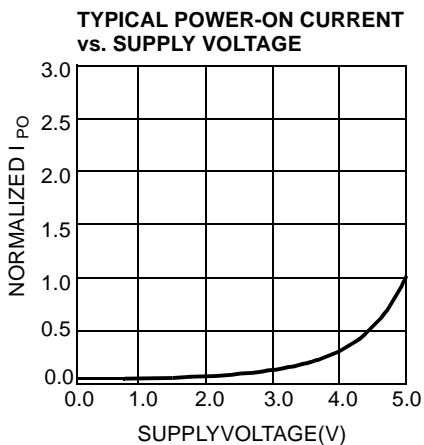
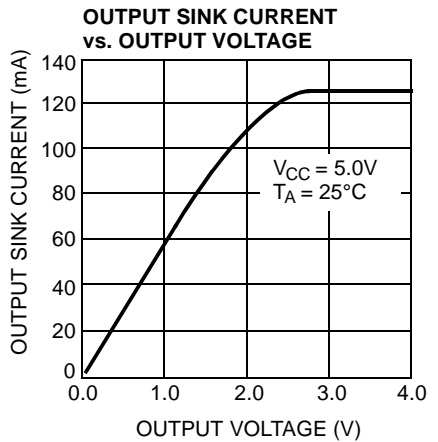
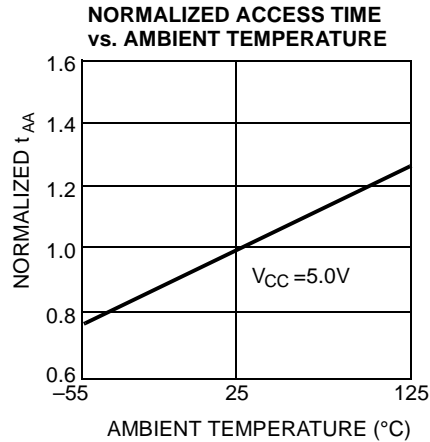
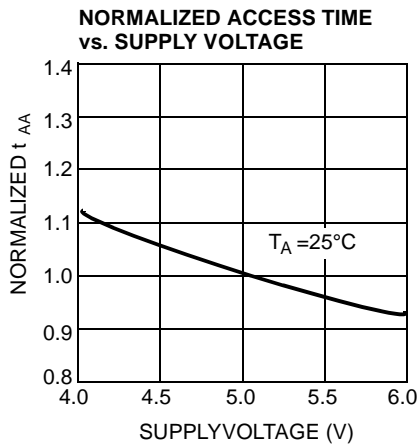
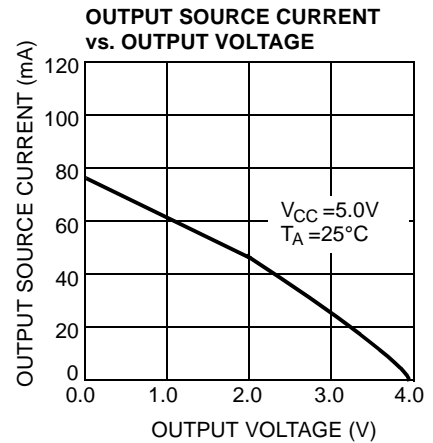
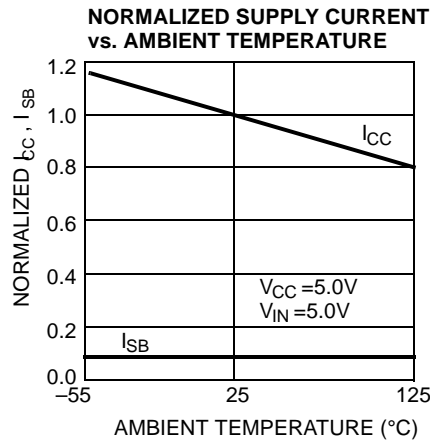
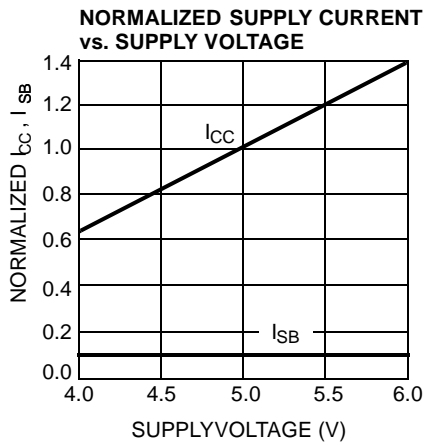
9. Device is continuously selected. \overline{OE} , $\overline{CE}_1 = V_{IL}$. $CE_2 = V_{IH}$.
10. \overline{WE} is HIGH for read cycle.
11. Data I/O is High Z if $\overline{OE} = V_{IH}$, $\overline{CE}_1 = V_{IH}$, or $\overline{WE} = V_{IL}$.
12. Address valid prior to or coincident with \overline{CE}_1 transition LOW and CE_2 transition HIGH.
13. During this period, the I/Os are in the output state and input signals should not be applied.

Switching Waveforms (continued)
Write Cycle No. 2 (\overline{CE} Controlled)^[11,12,14]

Write Cycle No. 3 (\overline{WE} Controlled, \overline{OE} LOW)^[11, 14]

Notes:

14. If \overline{CE}_1 goes HIGH simultaneously with \overline{WE} HIGH, the output remains in a high-impedance state.

Typical DC and AC Characteristics

Truth Table

\overline{CE}_1	\overline{CE}_2	WE	OE	Input/Output	Mode
H	X	X	X	High Z	Deselect/Power-Down
X	L	X	X	High Z	Deselect
L	H	H	L	Data Out	Read
L	H	L	X	Data In	Write
L	H	H	H	High Z	Deselect

Address Designators

Address Name	Address Function	DIP Pin Number	TSOP Pin Number
A4	X3	2	11
A5	X4	3	12
A6	X5	4	13
A7	X6	5	14
A8	X7	6	15
A9	Y1	7	16
A10	Y4	8	17
A11	Y3	9	18
A12	Y0	10	19
A0	Y2	21	32
A1	X0	23	2
A2	X1	24	3
A3	X2	25	4

Ordering Information

Speed (ns)	Ordering Code	Package Name	Package Type	Operating Range
20	CY7C186-20PC	P15	28-Lead (600-Mil) Molded DIP	Commercial
	CY7C186-20ZC	Z32	32-Lead Thin Small Outline Package	
25	CY7C186-25PC	P15	28-Lead (600-Mil) Molded DIP	Commercial
35	CY7C186-35PC	P15	28-Lead (600-Mil) Molded DIP	Commercial

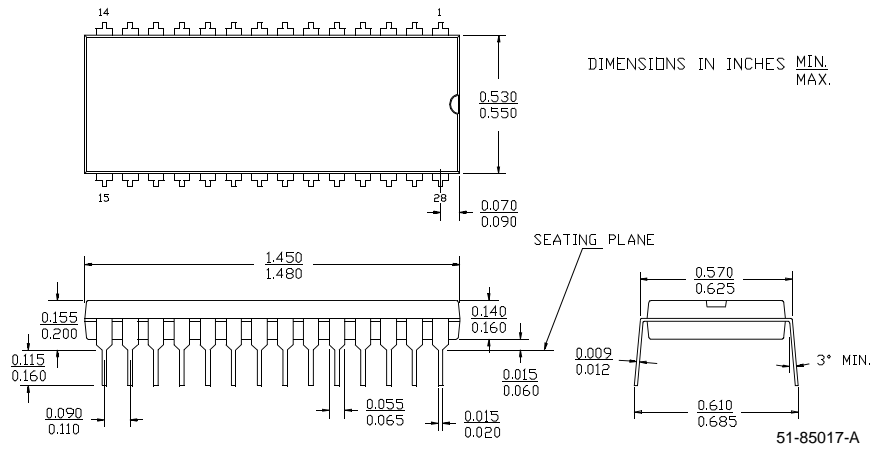
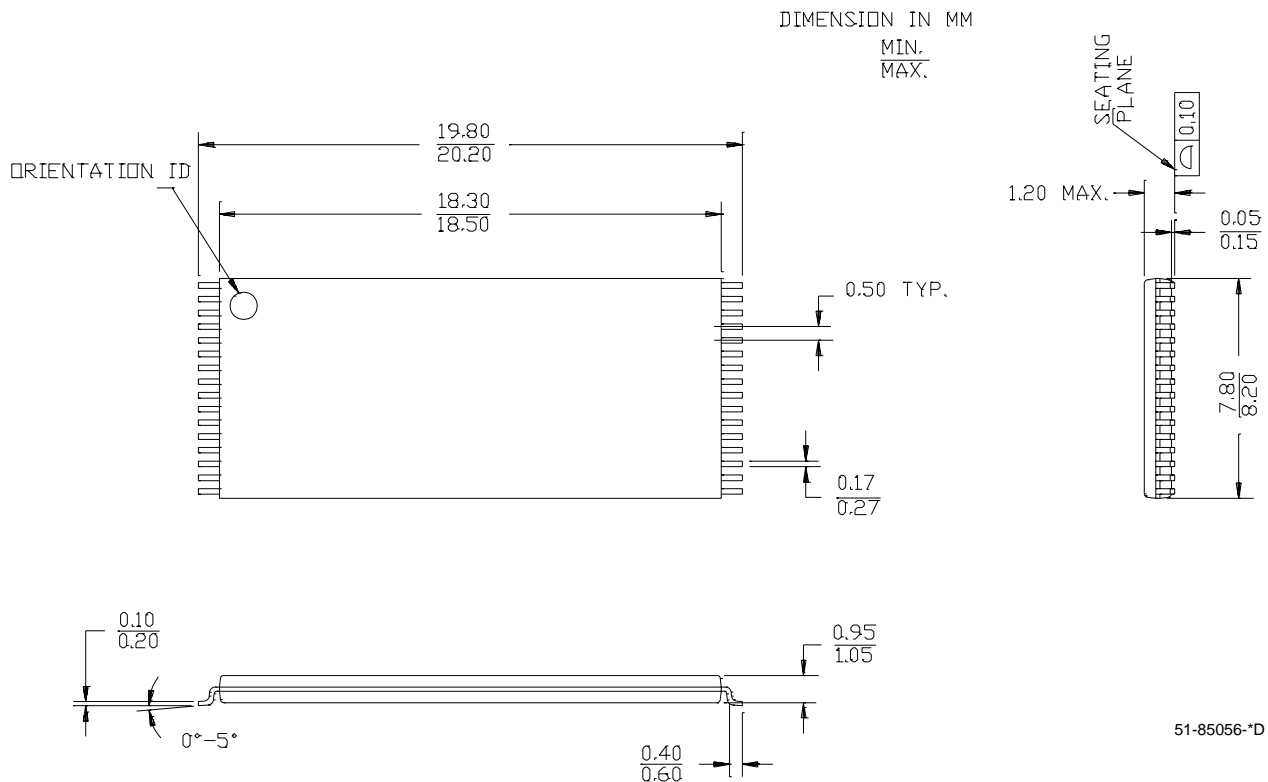
Package Diagrams
28-Lead (600-Mil) Molded DIP P15

32-Lead Thin Small Outline Package Type I (8x20 mm) Z32

Document Title: CY7C186 8Kx8 Static RAM Document Number: 38-05280				
REV.	ECN NO.	Issue Date	Orig. of Change	Description of Change
**	114447	3/26/02	DSG	Change from Spec number: 38-00240 to 38-05280

This datasheet has been downloaded from:

www.DatasheetCatalog.com

Datasheets for electronic components.



LittleDiode supplies new, hard to find or obsolete electronic components and semiconductors all over the world.

With over two million different components listed you are sure to find the part you need.

Feel free to visit us today at our online store:

LittleDiode.com

Looking forward to providing you with the best possible service.