

**CMOS 16-bit Single Chip Microcomputer**

**Piggy/  
evaluation type**

**Description**

The CXP921000A is a CMOS 16-bit single chip microcomputer of piggyback/evaluator combined type, which is developed for evaluating the function of the CXP921064A.

**Features**

- An efficient instruction set as a controller
  - Direct addressing, numerous abbreviated forms, multiplication and division instructions
- Instruction sets for C language and RTOS
  - Highly quadratic instruction system, general-purpose register of eight 16-bit × 16-bank configuration
- Minimum instruction cycle time    100ns at 20MHz operation (2.7 to 3.3V)  
     61µs at 32kHz operation (2.2 to 3.3V)
- Incorporated EPROM                    CXP27V1000K
- Incorporated RAM capacity          10K bytes
- Peripheral functions
  - A/D converter                            8-bit 12 analog input, 2 channels successive approximation system, automatic scanning function, (Conversion time: 3.4µs at 20MHz)
  - Serial interface                        128 -byte buffer RAM, 3 channels
  - I<sup>2</sup>C bus interface                      8-stage FIFO, 1 channel (supports special mode master/slave)
  - 64-byte buffer RAM , 2 channels (supports master/slave and automatic transfer mode)
  - Timers                                    8-bit timer/counter, 2 channels (with timing output)
  - 16-bit timer, 3 channels
  - Real-time pulse generator          5-bit output, 1 channel (2-stage FIFO)
  - Clock prescaler
  - Remote control receive circuit    8-bit pulse measurement counter, 8-stage FIFO
- Interruption                            30 factors, 30 vectors, multi-interruption and priority selection possible
- Standby mode                            Sleep/stop
- Package                                    100-pin Ceramic PQFP
- Mask ROM                                CXP921064A
- FLASH EEPROM incorporated type   CXP921F064A

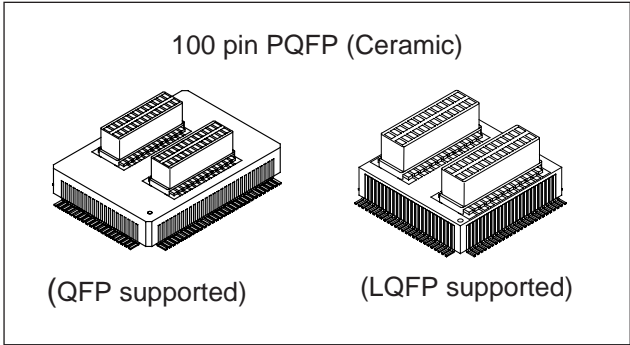

**Structure**

Silicon gate CMOS IC

Sony reserves the right to change products and specifications without prior notice. This information does not convey any license by any implication or otherwise under any patents or other right. Application circuits shown, if any, are typical examples illustrating the operation of the devices. Sony cannot assume responsibility for any problems arising out of the use of these circuits.

Pin Assignment in Piggyback Mode (Top View) 100-pin QFP package

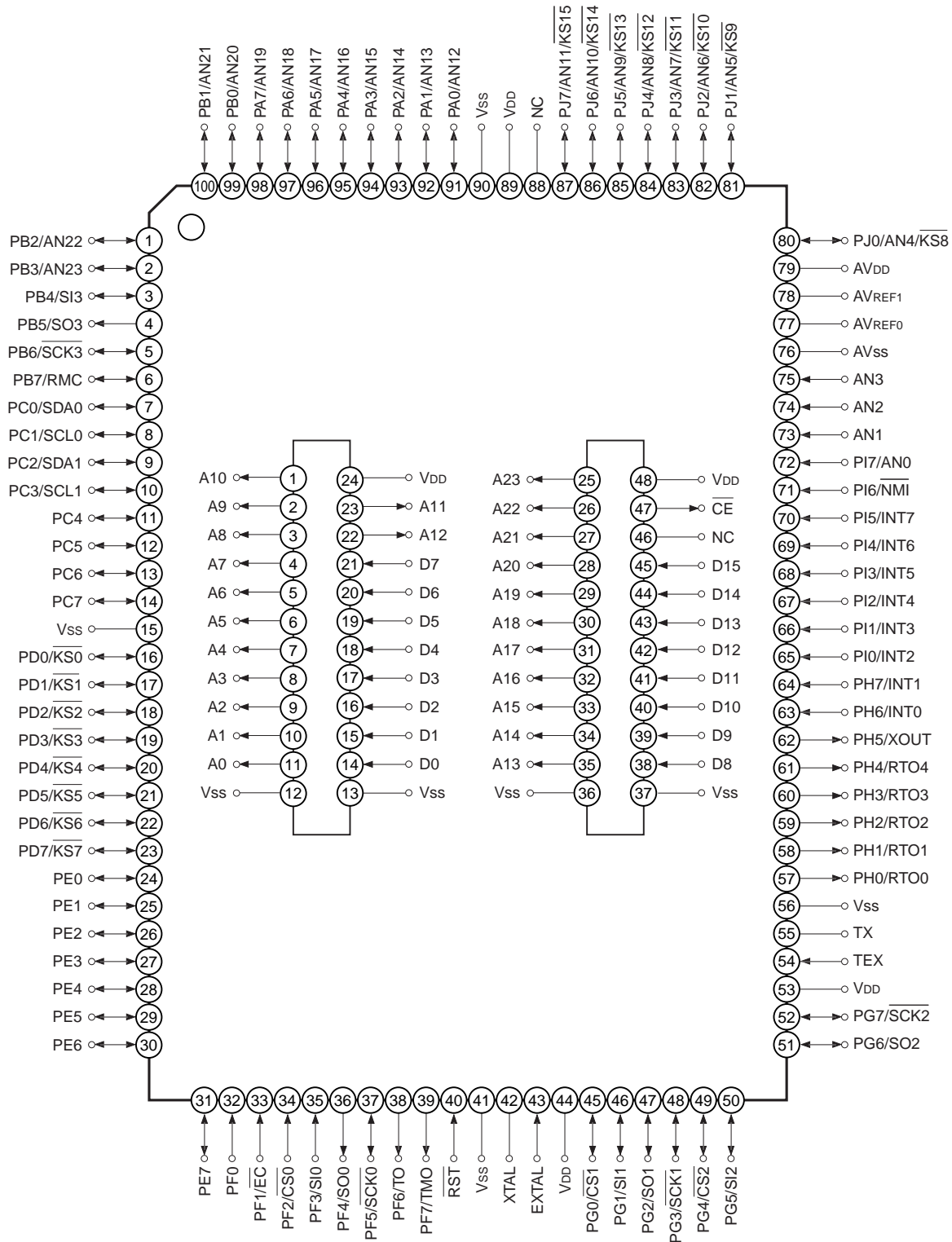

- Note)**
1. NC (Pin 88) must be left open. However, use this pin for FLASH EEPROM incorporated version.
  2. Vss (Pins 15, 41, 56 and 90) must be connected to GND.
  3. VDD (Pins 44, 53 and 89) must be connected to VDD.
  4. A20 to A23 are always high level output.

Pin Assignment in Evaluator Mode (Top View) 100-pin QFP package

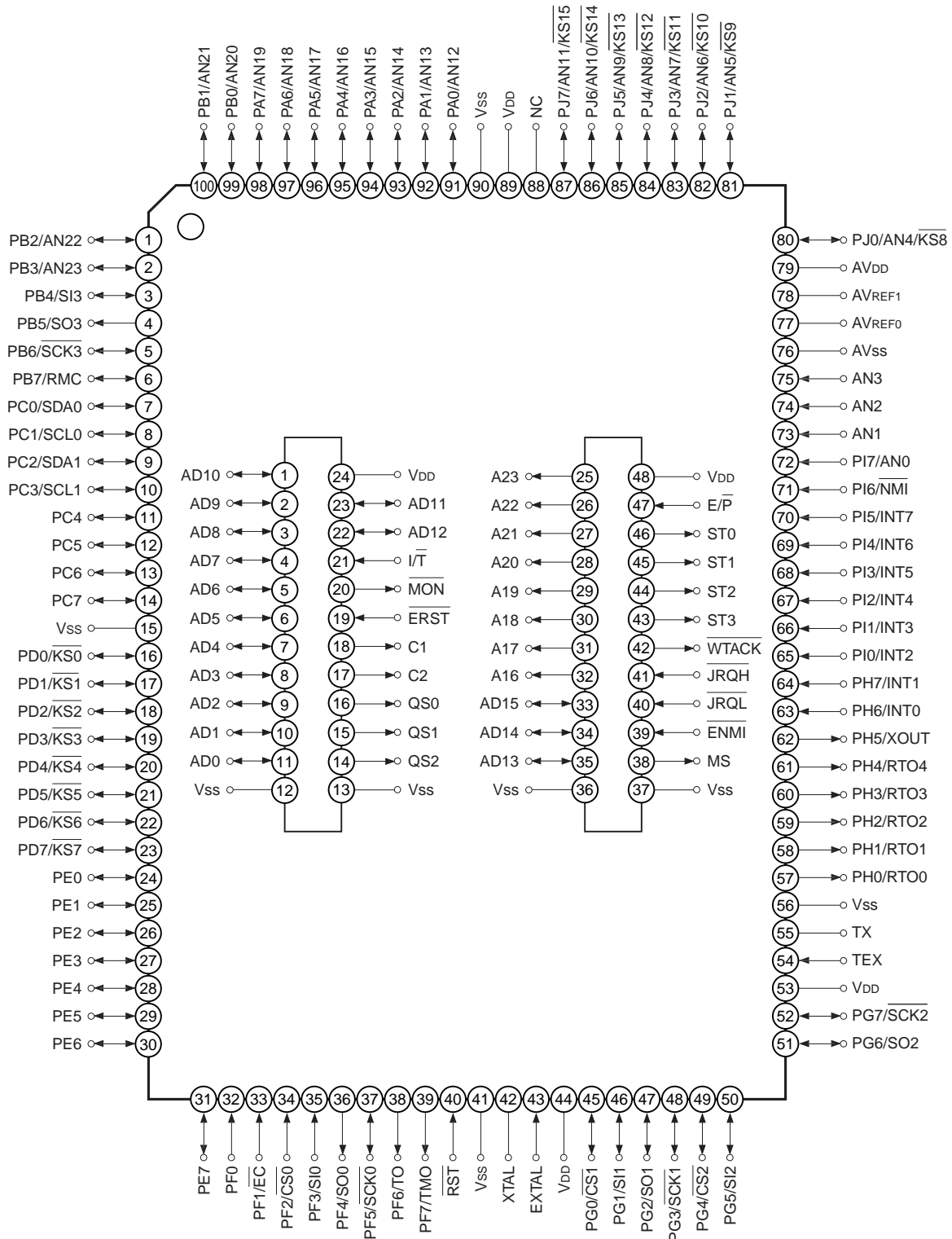

- Note)**
1. NC (Pin 88) must be left open. However, use this pin for FLASH EEPROM incorporated version.
  2. Vss (Pins 15, 41, 56 and 90) must be connected to GND.
  3. VDD (Pins 44, 53 and 89) must be connected to VDD.

Pin Assignment in Piggyback Mode (Top View) 100-pin LQFP package

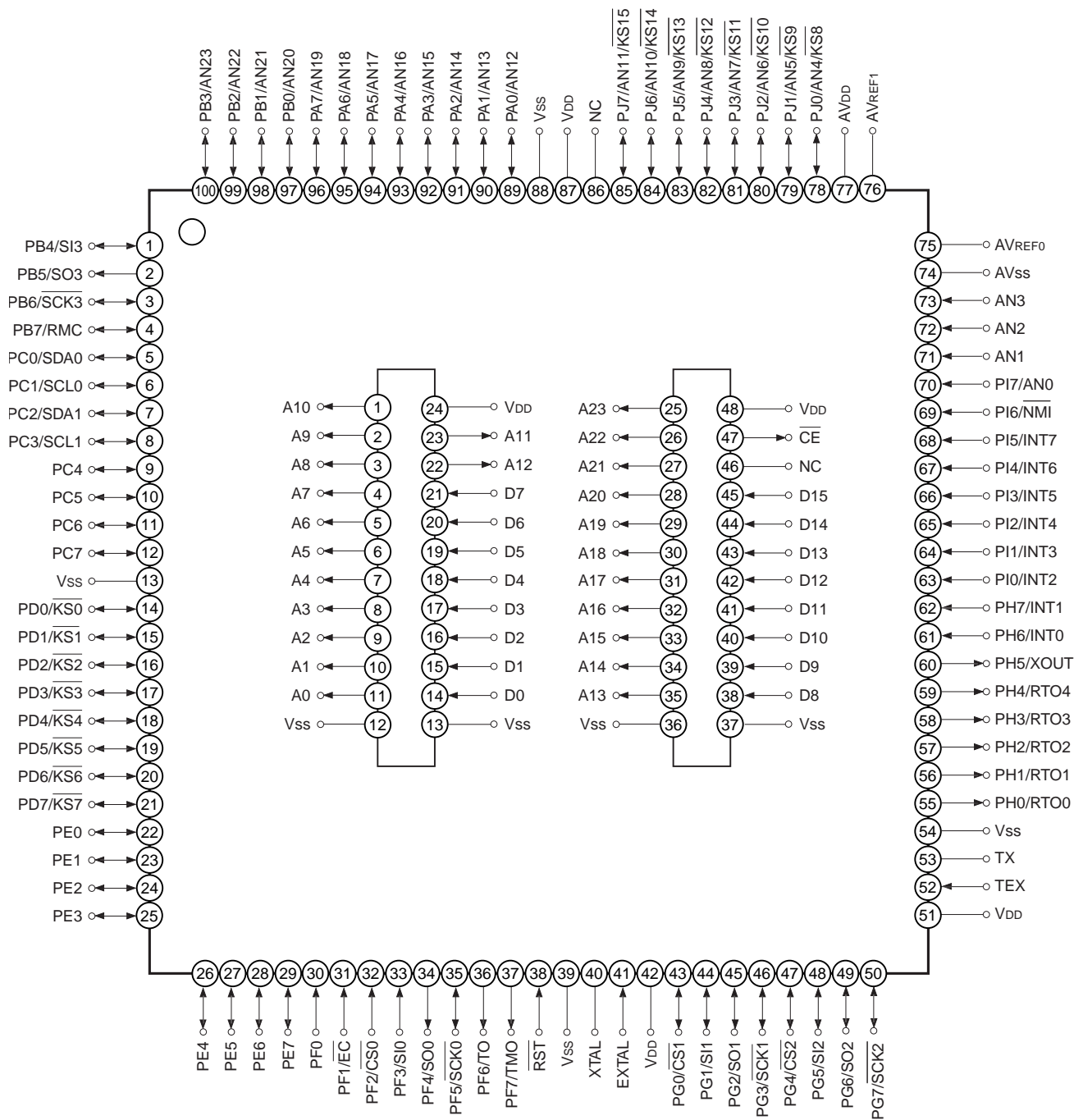

- Note)**
1. NC (Pin 86) must be left open. However, use this pin for FLASH EEPROM incorporated version.
  2. Vss (Pins 13, 39, 54 and 88) must be connected to GND.
  3. VDD (Pins 42, 51 and 87) must be connected to VDD.
  4. A20 to A23 are always high level output.

Pin Assignment in Evaluator Mode (Top View) 100-pin LQFP package

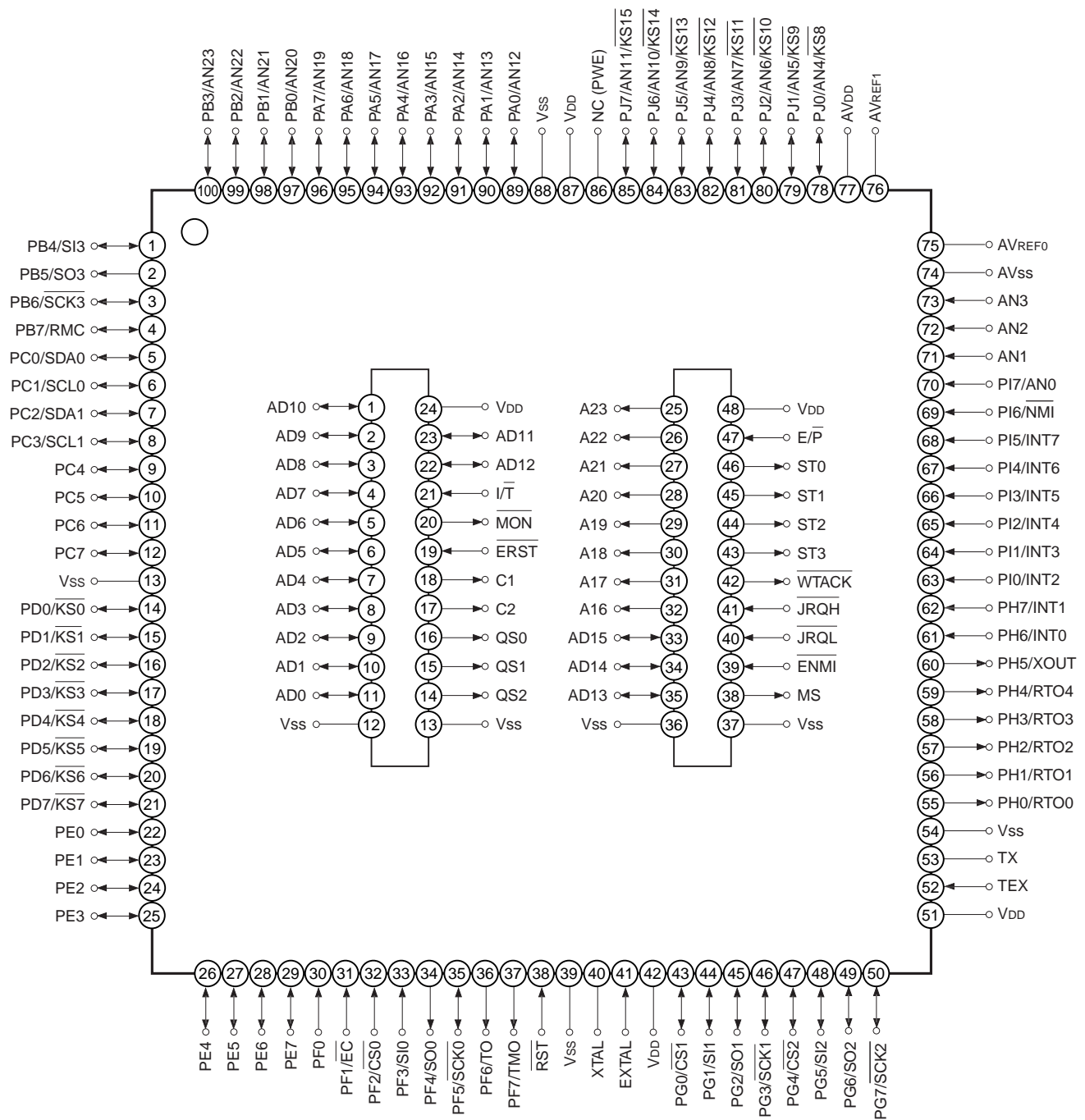

- Note)**
1. NC (Pin 86) must be left open. However, use this pin for FLASH EEPROM incorporated version.
  2. Vss (Pins 13, 39, 54 and 88) must be connected to GND.
  3. VDD (Pins 42, 51 and 87) must be connected to VDD.

**EPROM Read Timing**

( $T_a = -20$  to  $+75^\circ\text{C}$ ,  $V_{DD} = 2.7$  to  $3.3\text{V}$ ,  $V_{SS} = 0\text{V}$ )

Item	Symbol	Pins	Min.	Max.	Unit
Address → data Input delay time	$t_{ACC}$	A0 to A23 D0 to D15		50	ns
Address → data hold time	$t_{IH}$	A0 to A23 D0 to D15	0		ns

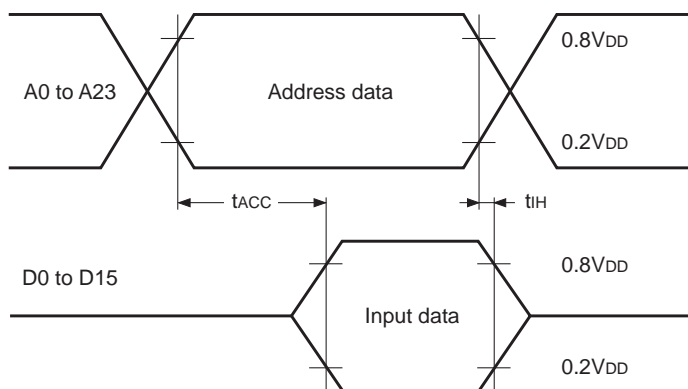

**Product List**

Optional item	Products		
	Mask ROM	Piggy/evaluation chip	
	CXP921064A	CXP921000A-U01Q	CXP921000A-U01R
Package	100-pin plastic QFP/LQFP 104-pin plastic LFLGA	100-pin ceramic PQFP (QFP supported)	100-pin ceramic PQFP (LQFPsupported)
ROM capacity	256K bytes	EPROM 256K bytes	
Reset pin pull-up resistor	Existent/Non-existent	Existent	

**Switching of Piggyback Mode and Evaluator Mode**

Piggyback mode can be used by setting two LCC-type EPROM (for upper bytes, for lower byte) and connecting to the connector of top of the chip.

Evaluator mode can be used by connecting in-circuit emulator CPU probe to the connector of top of the chip.

**Piggyback mode**

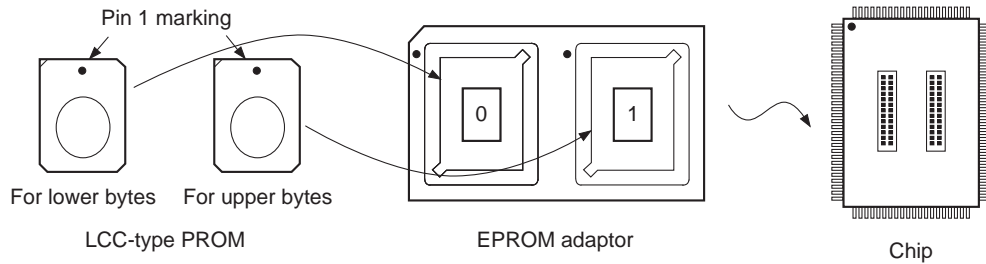

**Evaluator mode**

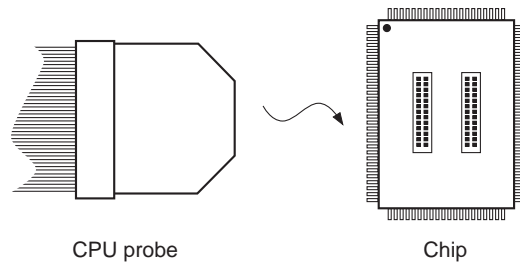

**Notes on PF7 Usage**

FLASH EEPROM incorporated PF7 is also used as flash mode setting function. Note the followings:

1. "H" is output to PF7 during a reset. That is driven at comparatively high impedance (approximately 150kΩ), and take care that  $V_{OH}$  should not fall under  $0.7V_{DD}$  by the partial pressure with external circuit load impedance.
2. When using software reset functions, PF7 may not rise enough during a reset. Switching PF7 to "H" output prior to software reset execution or connecting pull-up resistor is recommended.

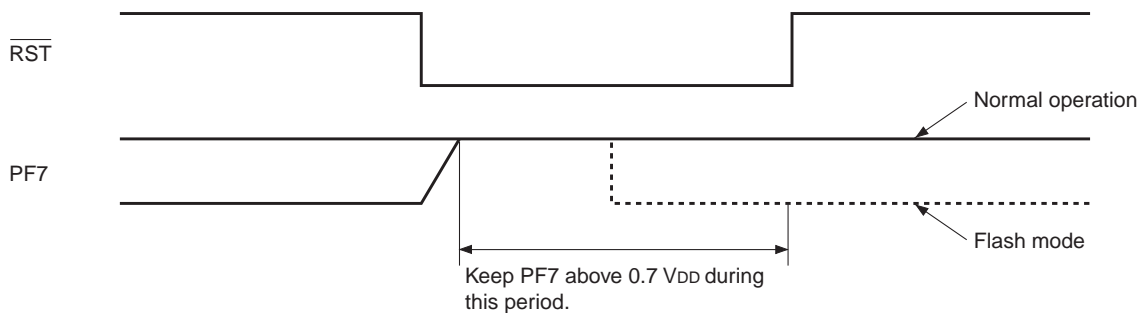

Mask ROM and piggy/evaluation chip do not have flash mode setting function. Considering that EEPROM incorporated type is used, above countermeasure should be performed.



100PIN PQFP(CERAMIC)

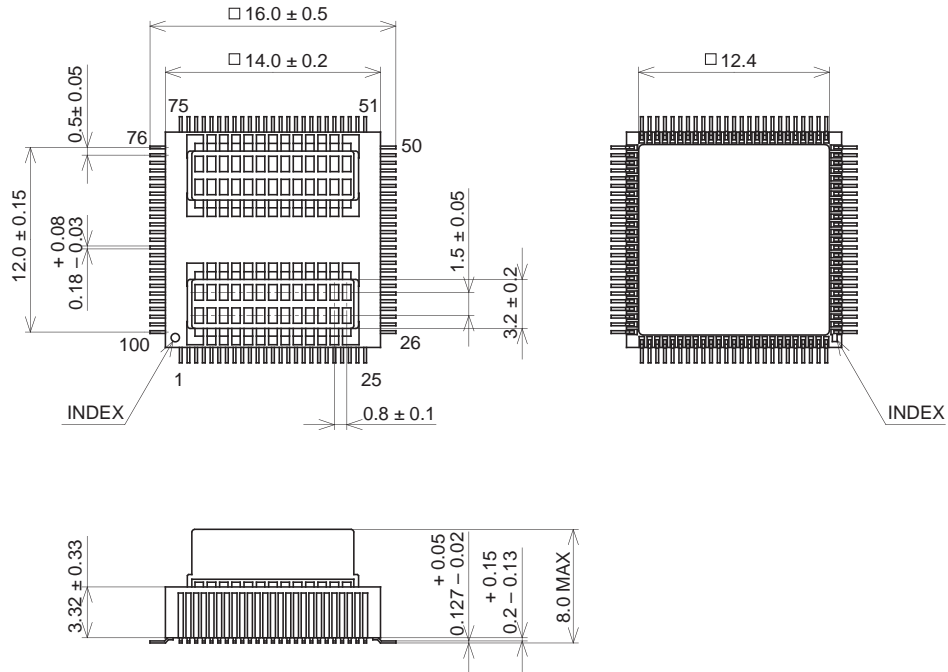

PACKAGE STRUCTURE

SONY CODE	PQFP-100C-L03
EIAJ CODE	AQFP100-C-0000
JEDEC CODE	_____

PACKAGE MATERIAL	CERAMIC
LEAD TREATMENT	GOLD PLATING
LEAD MATERIAL	42 ALLOY
PACKAGE MASS	2.7g



LittleDiode supplies new, hard to find or obsolete electronic components and semiconductors all over the world.

With over two million different components listed you are sure to find the part you need.

Feel free to visit us today at our online store:

[LittleDiode.com](http://LittleDiode.com)

Looking forward to providing you with the best possible service.