

CMOS 8-bit Single Chip Microcomputer

Description

The CXP875P40 is a CMOS 8-bit micro-computer which consists of arithmetic coprocessor, A/D converter, serial interface, timer/counter, time base timer, vector interruption, high precision timing pattern generation circuit, PWM generator and the measuring circuit which measure signals of capstan FG, drum FG/PG, reel FG and other servo systems, as well as basic configurations like 8-bit CPU, PROM, RAM and I/O port. They are integrated into a single chip.

Also this IC provides power on reset function, sleep/stop function which enables to lower power consumption.

The CXP875P40 is the one-chip PROM version of the CXP87532/87540 with mask ROM, providing the function of being able to write directly into the program. It is suitable for evaluation use during system development and for small quantity production.

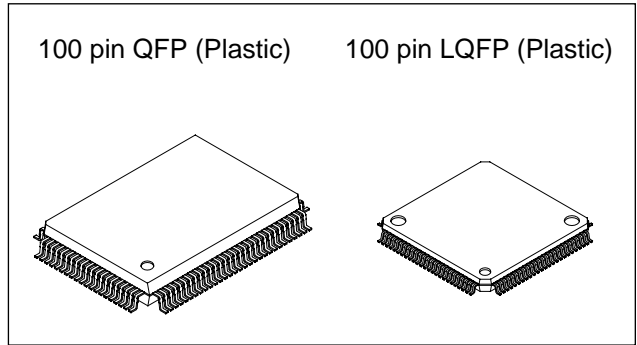

Structure

Silicon gate CMOS IC

Features

- A wide instruction set (213 instructions) which cover various types of data
 - 16-bit operation code/multiplying instruction/boolean bit operation instruction
- Minimum instruction cycle During operation 326ns/12.288MHz
- Incorporated PROM capacity 40K bytes
- Incorporated RAM capacity 1344 bytes
- Peripheral functions
 - Arithmetic coprocessor Multiplying with code, sum of products with code, high speed execution of many bits shift rotation operation
 - A/D converter 8-bit, 8-channel, successive approximation system (Conversion time 13µs/12.288MHz)
Incorporated 3-stage FIFO for A/D conversion data
 - Serial interface Incorporated buffer RAM for data (1 to 128 bytes auto transfer) 2-channel
 - Timer 8-bit timer, 8-bit timer/counter, 19-bit time base timer
 - High precision timing pattern generator PPG (11 pins) 32-stage programmable
 - PWM output 12-bit, 2-channel (Repeated frequency 48kHz)
8-bit, 3-channel (Repeated frequency 48kHz)
 - Servo input control Capstan FG, Drum FG/PG, Reel FG input
 - FRC capture unit Incorporated 28-bit and 8-stage FIFO
- Interruption 12 factors, 12 vectors, multi-interruption possible
- Standby mode SLEEP/STOP
- Package 100-pin plastic QFP/LQFP

Sony reserves the right to change products and specifications without prior notice. This information does not convey any license by any implication or otherwise under any patents or other right. Application circuits shown, if any, are typical examples illustrating the operation of the devices. Sony cannot assume responsibility for any problems arising out of the use of these circuits.

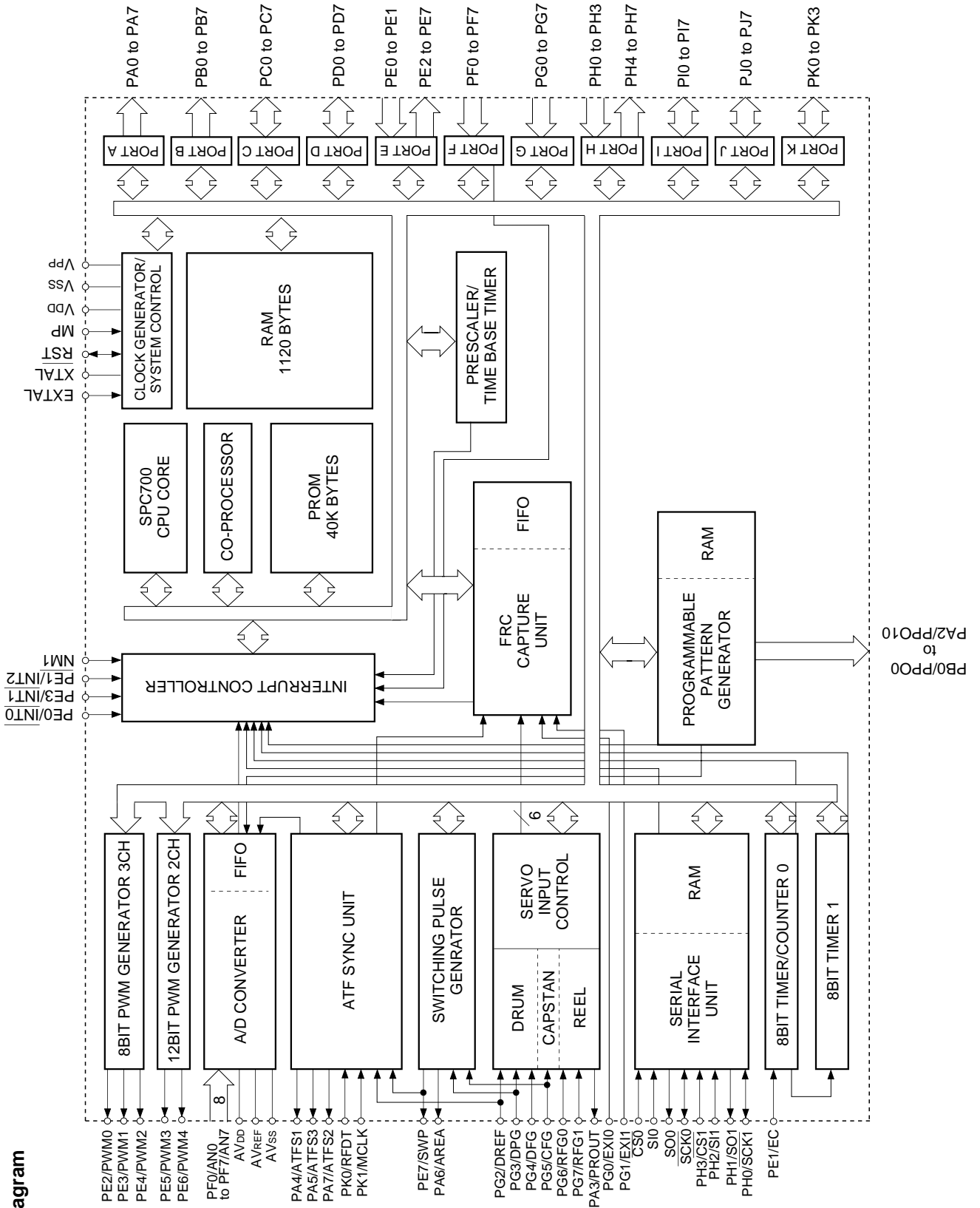

Pin Configuration 1 (Top View) 100pin QFP

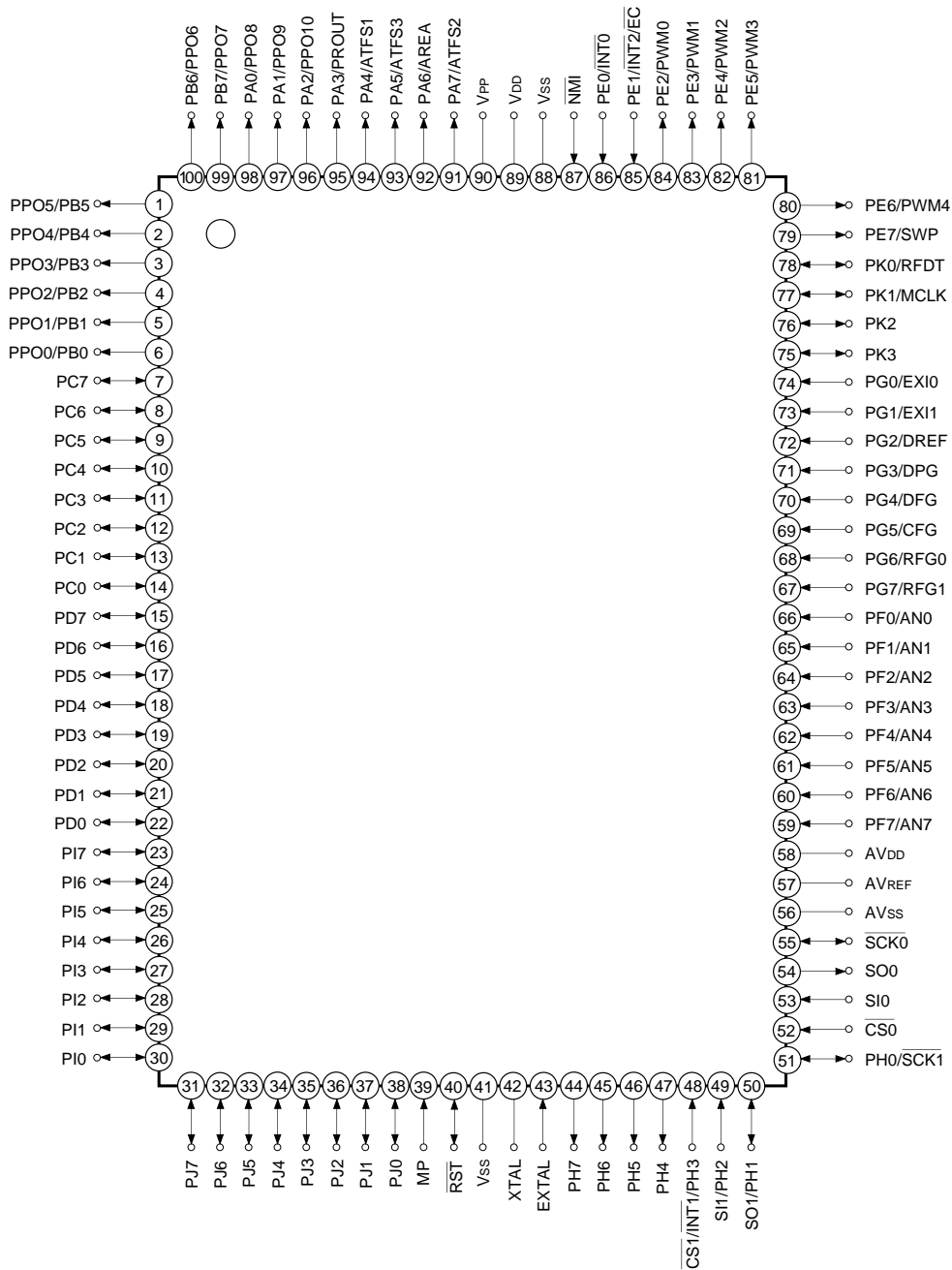

- Note)**
1. VPP (Pin 90) is always connected to VDD.
 2. VSS (Pins 41 and 88) are both connected to GND.
 3. MP (Pin 39) is always connected to VSS.

Pin Configuration 2 (Top View) 100pin LQFP

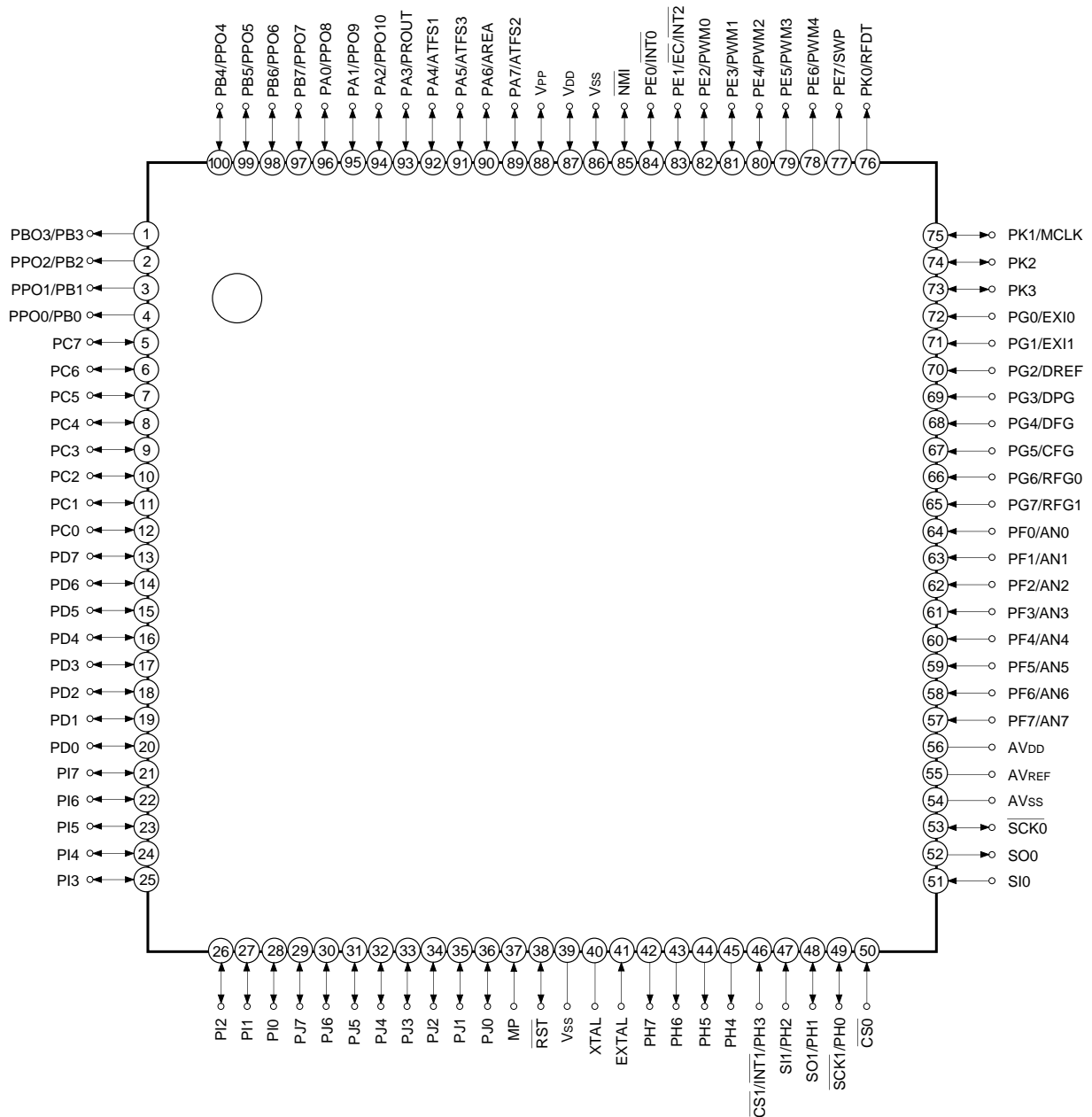

- Note)**
1. VPP (Pin 88) is always connected to VDD.
 2. Vss (Pins 39 and 86) are both connected to GND.
 3. MP (Pin 37) is always connected to Vss.

Pin Description

Symbol	I/O	Description		
PA0/PPO8 PA1/PPO9 PA2/PPO10 PA3/PROUT	Output/ Real time output	(Port A) 8-bit output port. Data is gated with PPO (3 pins), monitor signal (4 pins) in relation to ATF,	Programmable pattern generator (PPG) Output (3 pins) and capstan servo control signal (1 pin).	
PA4/ATFS1 PA5/ATFS3 PA6/AREA PA7/ATFS2	Output/ Monitor output	control signal (1 pin) for capstan servo by OR-gate and they are output. (8 pins)	Monitor output in relation to ATF. (4 pins)	
PB0/PPO0 to PB7/PPO7	Output/ Real time output	(Port B) 8-bit output port. Data is gated with PPO by OR-gate and they are output. (8 pins)	Programmable pattern generator (PPG) output. (8 pins)	
PC0 to PC7	I/O	(Port C) 8-bit input/output port, enables to specify input/output by 4-bit unit. (8 pins)		
PD0 to PD7	I/O	(Port D) 8-bit input/output port. Lower 4 bits can be specified as input/output by bit unit and upper 4 bits can be specified as input/output by 4-bit unit. (8 pins)		
PE0/ $\overline{\text{INT0}}$	Input/Input	(Port E) 8-bit port. Lower 2 bits are input pins and upper 6 bits are output pins. (8 pins)	Input pin to request external interruption. Active when falling edge.	
PE1/ $\overline{\text{EC}}/\overline{\text{INT2}}$	Input/Input/ Input		External event input pin for timer/counter.	Input pin to request external interruption. Active when falling edge.
PE2/PWM0 to PE6/PWM4	Output/Output		PWM output pins (5 pins)	
PE7/SWP	Output/Output		SWP output pin.	
PF0/AN0 to PF7/AN7	Input/Input	(Port F) 8-bit input port. (8 pins) Upper 4 bits serve as standby release input pin.	Analog input pins to A/D converter. (8 pins)	
PG0/EXI0	Input/Input	(Port G) 8-bit input port. (8 pins)	External input pin 0.	
PG1/EXI1	Input/Input		External input pin 1.	
PG2/DREF	Input/Input		Drum reference signal input pin.	
PG3/DPG	Input/Input		Drum PG input pin.	
PG4/DFG	Input/Input		Drum FG input pin.	
PG5/CFG	Input/Input		Capstan FG input pin.	
PG6/RFG0	Input/Input		Reel FG input pin.	
PG7/RFG1	Input/Input			

Symbol	I/O	Description	
PH0/ $\overline{\text{SCK1}}$	Input/I/O	(Port H) 4-bit input port. (4 pins)	Serial clock input/output pin.
PH1/SO1	Input/Output		Serial data output pin.
PH2/SI1	Input/Input		Serial data input pin.
$\overline{\text{PH3/INT1/CS1}}$	Input/Input/Input	Input pin to request external interruption. Active when falling edge.	Chip select input pin to serial interface.
PH7 to PH4	Output	(Port H) 4-bit output port. N-ch open drain output of middle tension proof (12V) and high current (12mA). (4 pins)	
PI0 to PI7	I/O	(Port I) 8-bit input/output port, enables to specify input/output by 4-bit unit. (8 pins)	
PJ0 to PJ7	I/O	(Port J) 8-bit input/output port, enables to specify input/output by 4-bit unit. (8 pins)	
PK0/RFD $\overline{\text{T}}$	I/O/Input	(Port K) 4-bit input/output port, enables to specify input/output by bit unit. (4 pins)	Playback data input pin.
PK1/MCLK	I/O/Input		Channel clock input pin.
PK2 to PK3	I/O		
$\overline{\text{SCK0}}$	I/O	Serial clock input/output pin.	
SO0	Output	Serial data output pin.	
SI0	Input	Serial data input pin.	
$\overline{\text{CS0}}$	Input	Chip select input pin to serial interface.	
$\overline{\text{NMI}}$	Input	Non-maskable interrupt request pin. Active during falling edge.	
EXTAL	Input	Connecting pin of crystal oscillator for system clock. When supplying the external clock, input the external clock to EXTAL pin and set XTAL pin to open.	
XTAL	Output		
$\overline{\text{RST}}$	I/O	System reset pin of active "L" level. $\overline{\text{RST}}$ pin is input/output pin, which output "L" level by incorporated power on reset function when power ON. (Mask option)	
MP	Input	Test mode pin. This pin is always connected to GND.	
AV _{DD}		Positive power supply pin of A/D converter. Set the same voltage as V _{DD} .	
AV _{REF}	Input	Reference voltage input pin of A/D converter.	
AV _{SS}		GND pin of A/D converter.	
V _{DD}		Positive power supply pin.	
V _{PP}		Positive power supply pin for incorporated PROM writing. In normal operation, connect to V _{DD} .	
V _{SS}		GND pin. Connect both V _{SS} pins to GND.	

I/O Circuit Formats for Pins

Pin	Circuit format	When reset
PA0/PPO8 to PA2/PPO10 PA3/PROUT PA4/ATFS1 PA5/ATFS3 PA6/AREA PA7/ATFS2 PB0/PPO0 to PB7/PPO7 16 pins	<p>Port A Port B</p> <p>PPO, PROUT, ATFS1 to ATFS3, AREA, data</p> <p>Port A or Port B</p> <p>Data bus</p> <p>RD</p> <p>Output becomes active from high impedance by data writing to port register.</p>	Hi-Z
PC0 to PC7 8 pins	<p>Port C</p> <p>Port C data</p> <p>Port C direction</p> <p>Data bus</p> <p>RD (Port C)</p> <p>(Every 4 bits)</p> <p>IP Input protection circuit</p> <p>Buffer</p>	Hi-Z
PD0 to PD7 8 pins	<p>Port D</p> <p>Port D data</p> <p>Port D direction</p> <p>Data bus</p> <p>RD (Port D)</p> <p>(Lower 4 bits are by bit unit and upper 4 bits are by 4-bit unit)</p> <p>IP</p> <p>Large current 12mA</p>	Hi-Z
PE0/ $\overline{\text{INT0}}$ PE1/ $\overline{\text{EC}}$ / INT2 2 pins	<p>Port E</p> <p>Schmitt input</p> <p>IP</p> <p>Data bus</p> <p>RD (Port E)</p>	Hi-Z

Pin	Circuit format	When reset
PE2/PWM0 PE3/PWM1 PE4/PWM2 PE5/PWM3 4 pins	<p>Port E</p> <p>PWM output</p> <p>Hi-Z control</p> <p>Port E data</p> <p>Port/PWM output select</p> <p>Data bus</p> <p>RD (Port E)</p> <p>MPX</p> <p>Hi-Z</p>	Hi-Z
PE6/PWM4 PE7/SWP 2 pins	<p>Port E</p> <p>PWM, SWP output</p> <p>Port E data</p> <p>Port/PWM, SWP output select</p> <p>Data bus</p> <p>RD (Port E)</p> <p>MPX</p> <p>H level</p>	H level
PF0/AN0 to PF7/AN7 8 pins	<p>Port F</p> <p>Input multiplexer</p> <p>IP</p> <p>A/D converter</p> <p>Analog/Digital input select</p> <p>Data bus</p> <p>RD (Port F)</p> <p>Hi-Z</p>	Hi-Z
PG0/EXI0 PG1/EXI1 PG2/DREF PG3/DPG PG4/DFG PG5/CFG PG6/RFG0 PG7/RFG1 8 pins	<p>Port G</p> <p>Schmitt input</p> <p>IP</p> <p>Servo input</p> <p>Data bus</p> <p>RD (Port G)</p> <p>For PG0/EXI0 to PG7/RFG1, TTL schmitt input can be selected with the mask option.</p> <p>Hi-Z</p>	Hi-Z

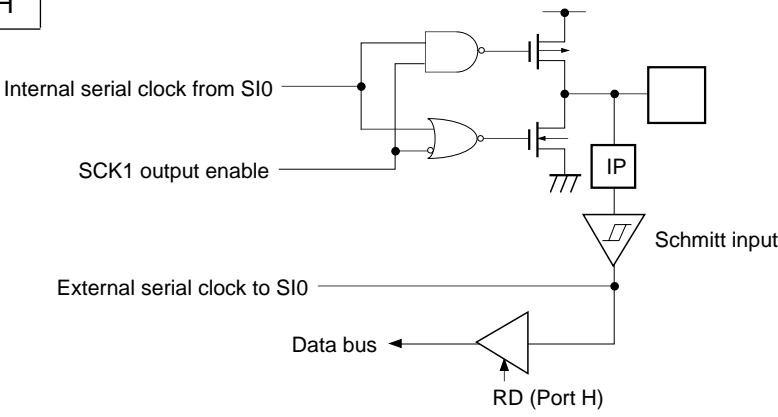
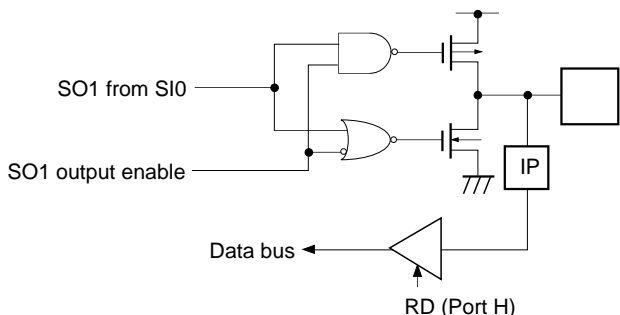
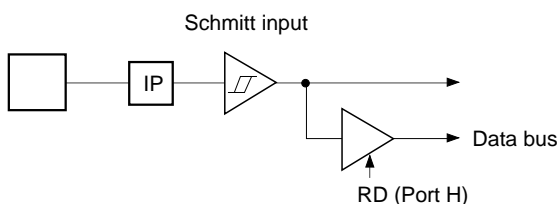
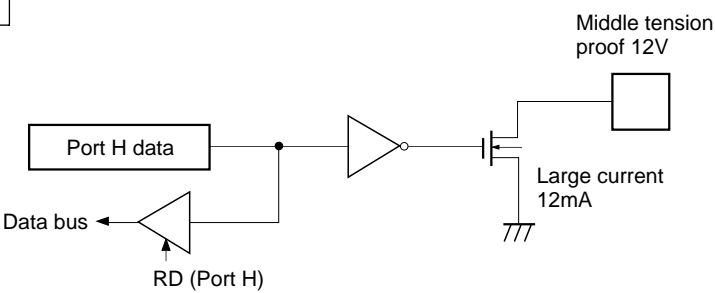
Pin	Circuit format	When reset
<p>PH0/SCK1</p> <p>1 pin</p>	<p>Port H</p> 	<p>Hi-Z</p>
<p>PH1/SO1</p> <p>1 pin</p>	<p>Port H</p> 	<p>Hi-Z</p>
<p>PH2/SI1 PH3/CS1/ INT1</p> <p>2 pins</p>	<p>Port H</p> 	<p>Hi-Z</p>
<p>PH4 to PH7</p> <p>4 pins</p>	<p>Port H</p> 	<p>Open</p>

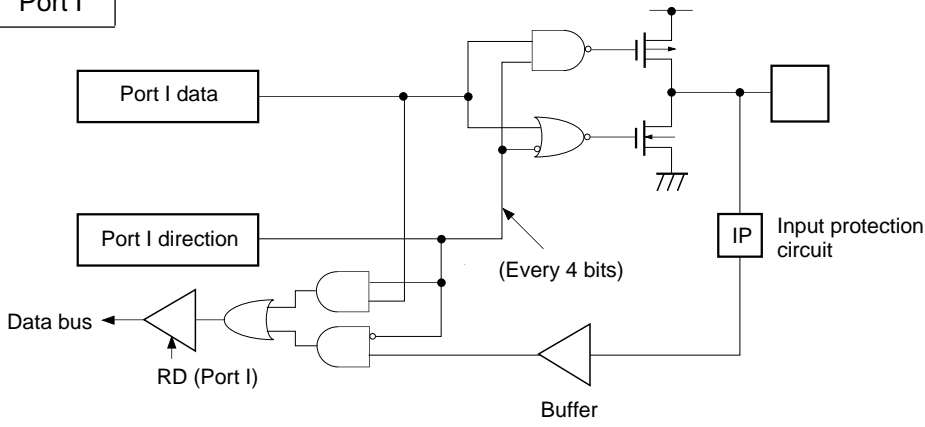
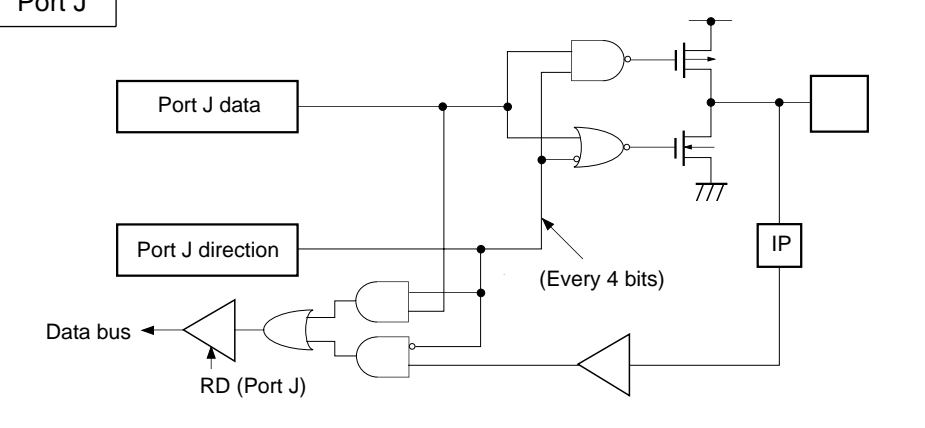
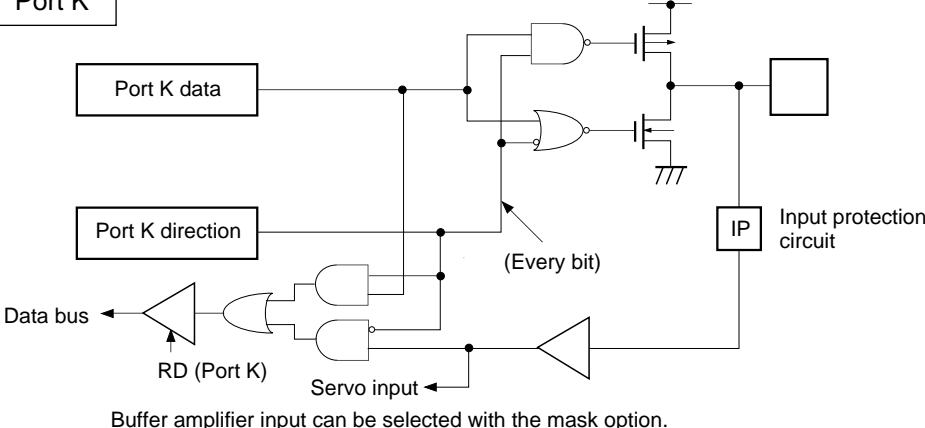
Pin	Circuit format	When reset
<p>PI0 to PI7</p> <p>8 pins</p>	<p>Port I</p>  <p>(Every 4 bits)</p> <p>IP Input protection circuit</p> <p>Buffer</p>	<p>Hi-Z</p>
<p>PJ0 to PJ7</p> <p>8 pins</p>	<p>Port J</p>  <p>(Every 4 bits)</p> <p>IP</p>	<p>Hi-Z</p>
<p>PK0/RFDT</p> <p>1 pin</p>	<p>Port K</p>  <p>(Every bit)</p> <p>IP Input protection circuit</p> <p>Servo input</p> <p>Buffer amplifier input can be selected with the mask option.</p>	<p>Hi-Z</p> <p>When buffer amplifier input is selected, pulled up internally during standby.</p>

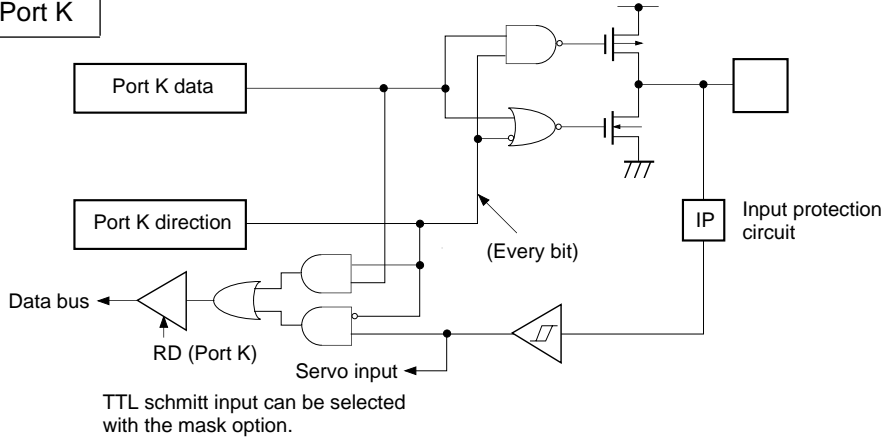
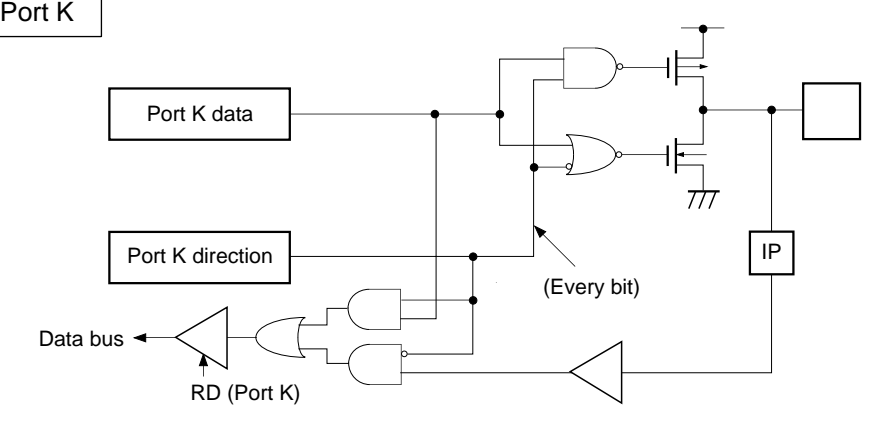
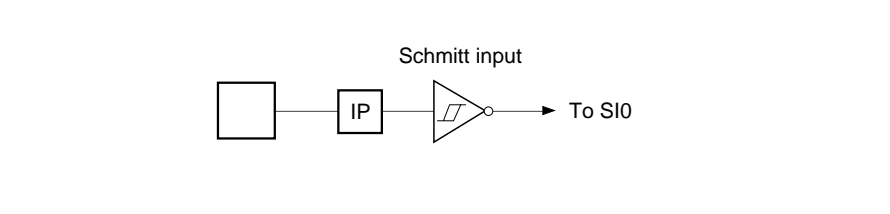
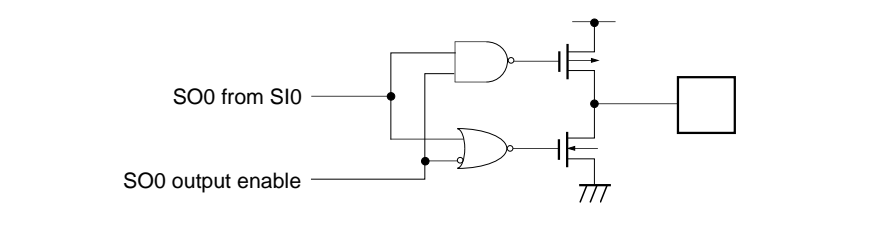
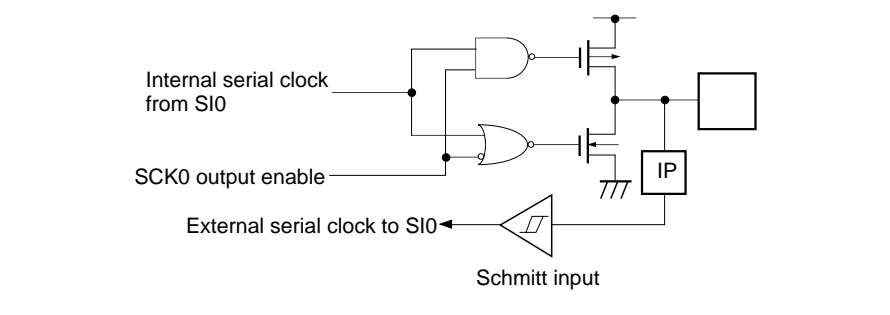
Pin	Circuit format	When reset
<p>PK1/MCLK</p> <p>1 pin</p>	<p>Port K</p>  <p>(Every bit)</p> <p>IP Input protection circuit</p> <p>Data bus</p> <p>RD (Port K)</p> <p>Servo input</p> <p>TTL schmitt input can be selected with the mask option.</p>	<p>Hi-Z</p>
<p>PK2 to PK3</p> <p>2 pins</p>	<p>Port K</p>  <p>(Every bit)</p> <p>IP</p> <p>Data bus</p> <p>RD (Port K)</p>	<p>Hi-Z</p>
<p>$\overline{\text{CS0}}$ SI0</p> <p>2 pins</p>	<p>Schmitt input</p>  <p>IP</p> <p>To SI0</p>	<p>Hi-Z</p>
<p>SO0</p> <p>1 pin</p>	 <p>SO0 from SI0</p> <p>SO0 output enable</p>	<p>Hi-Z</p>
<p>$\overline{\text{SCK0}}$</p> <p>1 pin</p>	 <p>Internal serial clock from SI0</p> <p>SCK0 output enable</p> <p>External serial clock to SI0</p> <p>Schmitt input</p> <p>IP</p>	<p>Hi-Z</p>

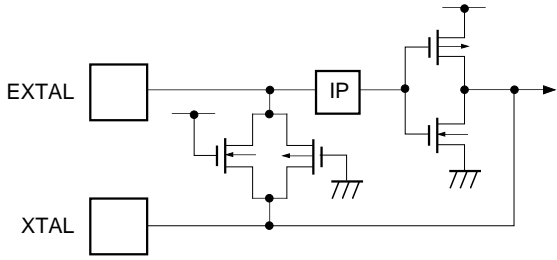
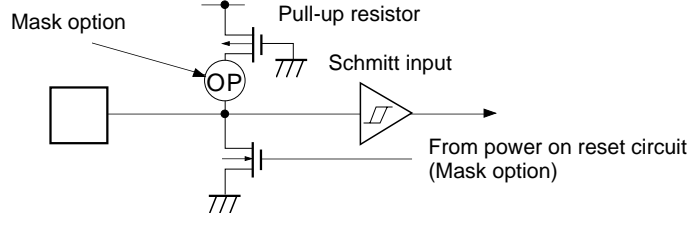
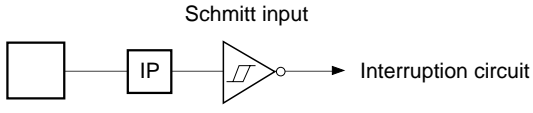
Pin	Circuit format	When reset
<p>EXTAL XTAL</p> <p>2 pins</p>	 <ul style="list-style-type: none"> • Shows the circuit composition during oscillation. • Feedback resistor is removed during stop. 	<p>Oscillation</p>
<p>$\overline{\text{RST}}$</p> <p>1 pin</p>	 <p>Mask option</p> <p>Pull-up resistor</p> <p>Schmitt input</p> <p>From power on reset circuit (Mask option)</p>	<p>L level</p>
<p>$\overline{\text{NMI}}$</p> <p>1 pin</p>	 <p>Schmitt input</p> <p>Interruption circuit</p>	<p>Hi-Z</p>

Absolute Maximum Ratings

(V_{SS} = 0V)

Item	Symbol	Ratings	Unit	Remarks
Power supply voltage	V _{DD}	-0.3 to +7.0	V	
	V _{PP}	-0.3 to +13.0	V	
	AV _{DD}	AV _{SS} to +7.0* ¹	V	PROM version only
	AV _{SS}	-0.3 to +0.3	V	
Input voltage	V _{IN}	-0.3 to +7.0* ²	V	
Output voltage	V _{OUT}	-0.3 to +7.0* ²	V	
Middle tension proof output voltage	V _{OUTP}	-0.3 to +15.0	mA	PH pin
High level output current	I _{OH}	-5	mA	
High level total output current	∑I _{OH}	-50	mA	Total of entire output pins
Low level output current	I _{OL}	15	mA	Other than large current output pins : per pin
	I _{OLC}	20	mA	Large current port pin * ³ : per pin
Low level total output current	∑I _{OL}	130	°C	Total of entire output pins
Operating temperature	T _{opr}	-10 to +75	°C	
Storage temperature	T _{stg}	-55 to +150		
Allowable power dissipation	P _D	600	mW	QFP package
		380		LQFP package

*¹ AV_{DD} and V_{DD} should be set to the same voltage.

*² V_{IN} and V_{OUT} should not exceed V_{DD} + 0.3V

*³ The large current operation transistors are the N-ch transistors of the PD and PH4 to PH7.

Note) Usage exceeding absolute maximum ratings may permanently impair the LSI. Normal operation should better take place under the recommended operating conditions. Exceeding those conditions may adversely affect the reliability of the LSI.

Recommended Operating Conditions

(V_{SS} = 0V)

Item	Symbol	Min.	Max.	Unit	Remarks
Power supply voltage	V _{DD}	4.5	5.5	V	Guaranteed range during operation
		2.5	5.5		Guaranteed data hold operation range during STOP
	V _{PP}	V _{PP} = V _{DD}		V	*6
Analog power supply	AV _{DD}	4.5	5.5	V	*1
High level input voltage	V _{IH}	0.7V _{DD}	V _{DD}	V	*2
	V _{IHS}	0.8V _{DD}	V _{DD}	V	CMOS schmitt input *3
	V _{IHTS}	2.2	V _{DD}	V	TTL schmitt input *4
	V _{IHEX}	V _{DD} - 0.4	V _{DD} + 0.3	V	EXTAL pin *5
Low level input voltage	V _{IL}	0	0.3V _{DD}	V	*2
	V _{ILS}	0	0.2V _{DD}	V	CMOS schmitt input *3
	V _{ILTS}	0	0.8	V	TTL schmitt input *4
	V _{ILEX}	-0.3	0.4	V	EXTAL pin *5
Operating temperature	T _{opr}	-10	+75	°C	

*1 AV_{DD} and V_{DD} should be set to the same voltage.

*2 Normal input port (Each pin of PC, PD, PF and PH1).

*3 Each pin of $\overline{\text{NMI}}$, $\overline{\text{CS0}}$, $\overline{\text{SI0}}$, $\overline{\text{SCK0}}$, $\overline{\text{RST}}$, $\overline{\text{PE0/INT0}}$, $\overline{\text{PE1/EC/INT2}}$, $\overline{\text{PH0/SCK1}}$, $\overline{\text{PH2/SI1}}$, $\overline{\text{PH3/INT1/CS1}}$, $\overline{\text{PG}}$ and $\overline{\text{PK1/MCLK}}$ (when CMOS schmitt input is selected with mask option for PG, PK1/MCLK).

*4 Each pin of PG and PK1/MCLK (when TTL schmitt input is selected with mask option).

*5 Specified only during external clock input.

*6 V_{PP} and V_{DD} should be set to same voltage.

DC Characteristics

(Ta = -10 to +75°C, Vss = 0V)

Item	Symbol	Pin	Condition	Min.	Typ.	Max.	Unit
High level output voltage	V _{OH}	PA to PD, PE2 to PE7, PH0, PH1, SO0, <u>SCK0</u> PH4 to PH7	V _{DD} = 4.5V, I _{OH} = -0.5mA	4.0			V
			V _{DD} = 4.5V, I _{OH} = -1.2mA	3.5			V
Low level output voltage	V _{OL}	(V _{OL} only) RST* ¹ (V _{OL} only) PI to PK	V _{DD} = 4.5V, I _{OL} = 1.8mA			0.4	V
			V _{DD} = 4.5V, I _{OL} = 3.6mA			0.6	V
		PD, PH4 to PH7	V _{DD} = 4.5V, I _{OL} = 12.0mA			1.5	V
Input current	I _{IHE}	EXTAL	V _{DD} = 5.5V, V _{IH} = 5.5V	0.5		40	μA
	I _{IIE}		V _{DD} = 5.5V, V _{IL} = 0.4V	-0.5		-40	μA
	I _{ILR}	<u>RST</u> * ²	V _{DD} = 5.5V, V _{IL} = 0.4V	-1.5		-400	μA
I/O leakage current	I _{Iz}	PA to PG PH0 to PH3, <u>CS0</u> , <u>SI0</u> , <u>SO0</u> , <u>SCK0</u> , <u>NMI</u> , <u>RST</u> * ² PI to PK* ³	V _{DD} = 5.5V V _I = 0, 5.5V			±10	μA
Open drain output leakage current (N-ch Tr OFF in state)	I _{LOH}	PH4 to PH7	V _{DD} = 5.5V V _{OH} = 12V			50	μA
Current power supply	I _{DD}	V _{DD}	Operating mode (1/2 dividing clock) 12.288MHz crystal oscillation (C ₁ = C ₂ = 12pF) Entire output pins open		20	45	mA
	I _{DDSL}				5	17	mA
	I _{DDST}					30	μA
Input capacity	C _{IN}	Other than V _{DD} , V _{SS} , AV _{DD} , and AV _{SS} pins	Clock 1MHz 0V other than the measured pins		10	20	pF

*¹ RST pin specifies only when the power on reset circuit is selected with mask option.

*² RST pin specifies the input current when the pull-up resistance is selected, and specifies leakage current when non-resistance is selected.

*³ PK0 pin specifies only when the normal input circuit is selected with mask option.

AC Characteristics

(1) Clock timing

($T_a = -10$ to $+75^\circ\text{C}$, $V_{DD} = 4.5$ to 5.5V , $V_{SS} = 0\text{V}$)

Item	Symbol	Pin	Condition	Min.	Max.	Unit
System clock frequency	f_c	XTAL EXTAL	Fig. 1, Fig. 2	1	12.288	MHz
System clock input pulse width	t_{XL} , t_{XH}	EXTAL	Fig. 1, Fig. 2 External clock drive	36		ns
System clock input rising and falling times	t_{CR} , t_{CF}	EXTAL	Fig. 1, Fig. 2 External clock drive		200	ns
Event count input clock pulse width	t_{EH} , t_{EL}	$\overline{\text{EC}}$	Fig. 3	$t_{\text{sys}} + 50^*$		ns
Event count input clock rising and falling times	t_{ER} , t_{EF}	$\overline{\text{EC}}$	Fig. 3		20	ms

* t_{sys} indicates three values according to the contents of the clock control register (address : 00FEH) upper 2 bits (CPU clock selection).

$t_{\text{sys}} \text{ (ns)} = 2000/f_c$ (Upper 2 bits = "00"), $4000/f_c$ (Upper 2 bits = "01"), $16000/f_c$ (Upper 2 bits = "11")

Fig. 1. Clock timing

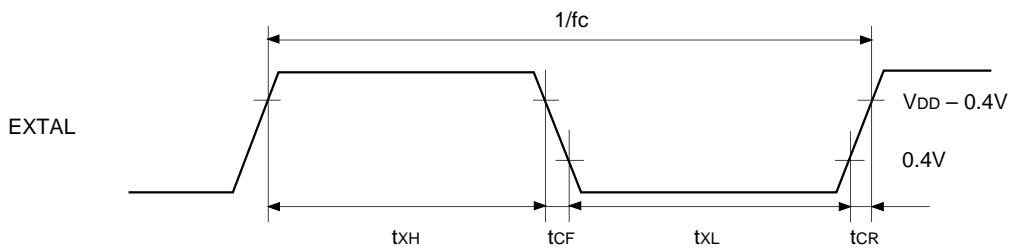

Fig. 2. Clock applying condition

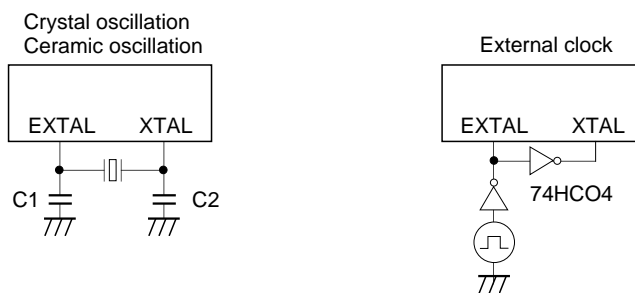
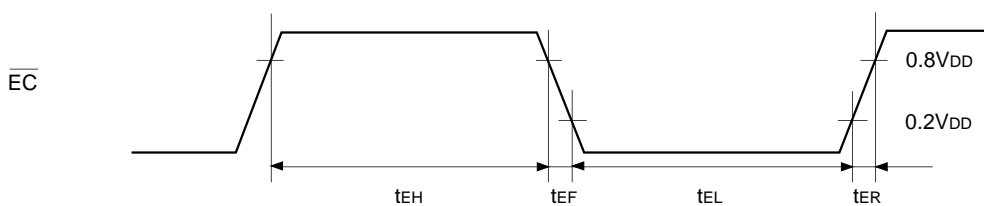

Fig. 3. Event count clock timing



(2) Serial transfer

(Ta = -10 to +75°C, VDD = 4.5 to 5.5V, VSS = 0V)

Item	Symbol	Pin	Condition	Min.	Max.	Unit
$\overline{CS} \downarrow \rightarrow \overline{SCK}$ delay time	t _{DCSK}	$\overline{SCK0}$, $\overline{SCK1}$	Chip select transfer mode (\overline{SCK} = Output mode)		t _{sys} + 200	ns
$\overline{CS} \uparrow \rightarrow \overline{SCK}$ floating delay time	t _{DCSKF}	$\overline{SCK0}$, $\overline{SCK1}$	Chip select transfer mode (\overline{SCK} = Output mode)		t _{sys} + 200	ns
$\overline{CS} \downarrow \rightarrow SO$ delay time	t _{DCSO}	SO0, SO1	Chip select transfer mode		t _{sys} + 200	ns
$\overline{CS} \uparrow \rightarrow SO$ floating delay time	t _{DCSOF}	SO0, SO1	Chip select transfer mode		t _{sys} + 200	ns
\overline{CS} high level width	t _{WHCS}	CS0, CS1	Chip select transfer mode	t _{sys} + 200		ns
\overline{SCK} cycle time	t _{KCY}	$\overline{SCK0}$, $\overline{SCK1}$	Input mode	2t _{sys} + 200		ns
			Output mode	8000/fc		ns
\overline{SCK} high and low level widths	t _{KH} t _{KL}	$\overline{SCK0}$, $\overline{SCK1}$	Input mode	t _{sys} + 100		ns
			Output mode	4000/fc - 50		ns
SI input setup time (against $\overline{SCK} \uparrow$)	t _{SIK}	SI0, SI1	\overline{SCK} input mode	-t _{sys} + 100		ns
			\overline{SCK} output mode	200		ns
SI input hold time (against $\overline{SCK} \uparrow$)	t _{KSI}	SI0, SI1	\overline{SCK} input mode	2t _{sys} + 100		ns
			\overline{SCK} output mode	100		ns
$\overline{SCK} \downarrow \rightarrow SO$ delay time	t _{KSO}	SO0, SO1	\overline{SCK} input mode		2t _{sys} + 200	ns
			\overline{SCK} output mode		100	ns

Note 1) t_{sys} indicates three values according to the contents of the clock control register (address : 00FEH) upper 2 bits (CPU clock selection).

t_{sys} (ns) = 2000/fc (Upper 2 bits = "00"), 4000/fc (Upper 2 bits = "01"), 16000/fc (Upper 2 bits = "11")

Note 2) The marks CS, SCK, SI and SO respectively mean pins of CS → CS0, CS1, SCK → SCK0, SCK1, SI → SI0, SI1 and SO → SO0, SO1.

Note 3) The load of \overline{SCK} output mode and SO output delay time is 50pF + 1TTL.

Fig. 4. Serial transfer timing

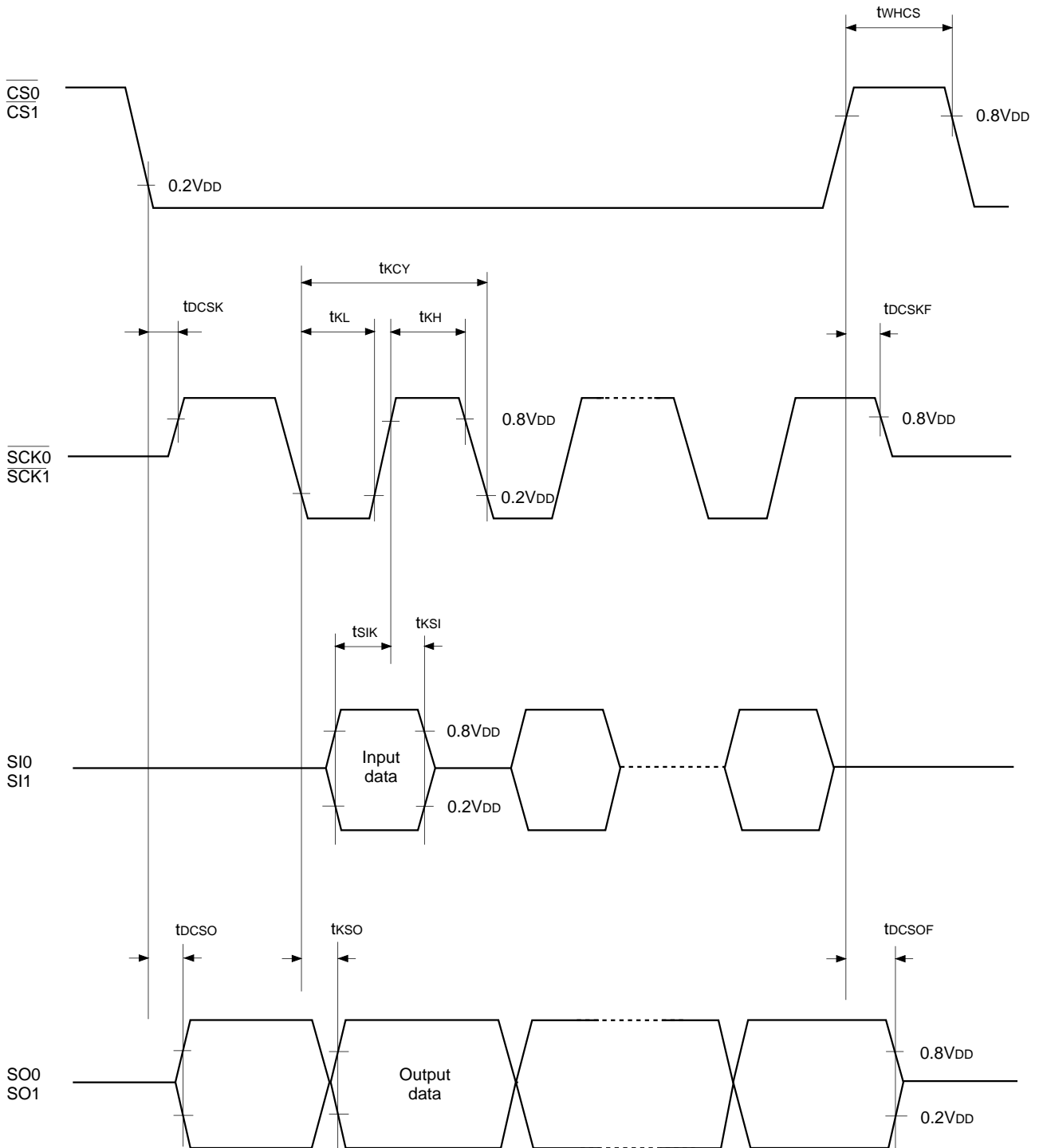

(3) A/D converter characteristics

($T_a = -10$ to $+75^\circ\text{C}$, $V_{DD} = AV_{DD} = 4.5$ to 5.5V , $AV_{REF} = 4.0$ to AV_{DD} , $V_{SS} = AV_{SS} = 0\text{V}$)

Item	Symbol	Pin	Condition	Min.	Typ.	Max.	Unit
Resolution						8	bits
Linearity error			$T_a = 25^\circ\text{C}$ $V_{DD} = AV_{DD} = 5.0\text{V}$ $V_{SS} = AV_{SS} = 0\text{V}$			± 1	LSB
Zero transition voltage	V_{ZT}^{*1}			-10	30	70	mV
Full scale transition voltage	V_{FT}^{*2}			4930	4970	5010	mV
Conversion time	t_{CONV}			$160/f_c$			μs
Sampling time	t_{SAMP}			$12/f_c$			μs
Reference input voltage	V_{REF}	AV_{REF}		$AV_{DD} - 0.5$		AV_{DD}	V
Analog input voltage	V_{IAN}	AN0 to AN7		0		AV_{REF}	V
AV_{REF} current	I_{REF}	AV_{REF}	Operating mode		0.6	1.0	mA
	I_{REFS}		SLEEP mode STOP mode			10	μA

Fig. 5. Definitions of A/D converter terms

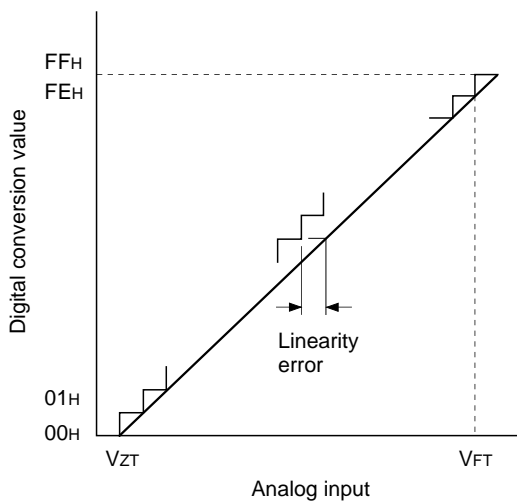

*1 V_{ZT} : Indicates the value that digital conversion value changes from 00H to 01H and vice versa.

*2 V_{FT} : Indicates the value that digital conversion value changes from FEH to FFH and vice versa.

(4) Interruption, reset input (Ta = -10 to +75°C, VDD = 4.5 to 5.5V, VSS = 0V)

Item	Symbol	Pin	Condition	Min.	Max.	Unit
External interruption high and low level widths	t _{IH} t _{IL}	$\overline{\text{INT0}}$ $\overline{\text{INT1}}$ $\overline{\text{INT2}}$ NMI		1		μs
Reset input low level width	t _{RSL}	$\overline{\text{RST}}$		8/fc		μs

Fig. 6. Interruption input timing

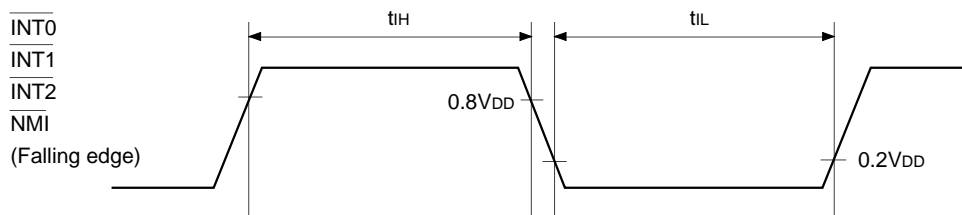
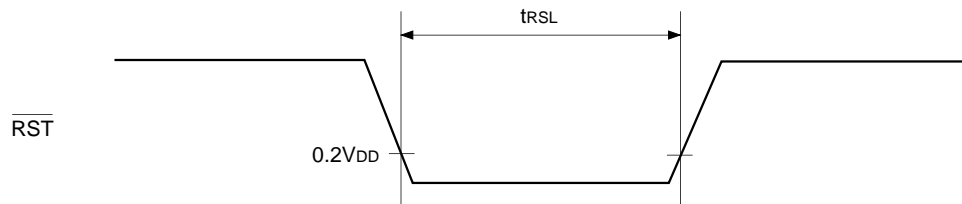

Fig. 7. $\overline{\text{RST}}$ input timing



(5) Power on reset

Power on reset* (Ta = -10 to +75°C, VDD = 4.5 to 5.5V, VSS = 0V)

Item	Symbol	Pin	Condition	Min.	Max.	Unit
Power supply rising time	t _R	V _{DD}	Power on reset	0.05	50	ms
Power supply cut-off time	t _{OFF}		Repetitive power on reset	1		ms

* Specifies only when power on reset function is selected.

Fig. 8. Power on reset

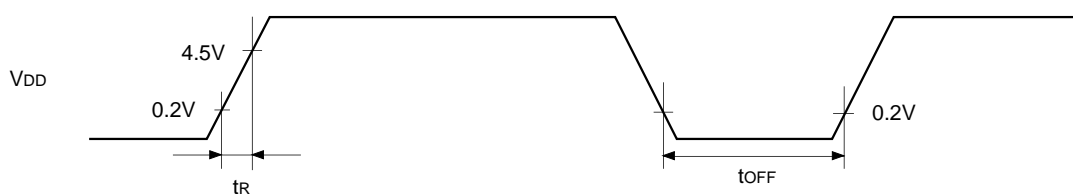

The power supply should rise smoothly.

(6) Others

(Ta = -10 to +75°C, VDD = 4.5 to 5.5V, VSS = 0V)

Item	Symbol	Pin	Condition	Min.	Max.	Unit
RFDT input high and low level widths	t_{RDH} t_{RDL}	RFDT		$2.5t_{MCK}^*$		ns
MCLK input high and low level widths	t_{MCH} t_{MCL}	MCLK		$326/f_c$		ns
DREF input high and low level widths	t_{DRH} t_{DRL}	DREF		$t_{sys} + 200$		ns
DPG input high and low level widths	t_{DPH} t_{DPL}	DPG		$t_{sys} + 200$		ns
DFG input high and low level widths	t_{DFH} t_{DFL}	DFG		$t_{sys} + 200$		ns
CFG input high and low level widths	t_{CFH} t_{CFL}	CFG		$t_{sys} + 200$		ns
RFG input high and low level widths	t_{RFH} t_{RFL}	RFG0 RFG1		$t_{sys} + 200$		ns
EXI input high and low level widths	t_{EIH} t_{EIL}	EXI0 EXI1	$t_{sys} = 2000/f_c$	$t_{sys} + 200$		ns

* t_{MCK} indicates three values according to the contents of the ATF control register (address : 01EEH) bits 5 and 4 (MCLK input control).

t_{MCK} (ns) = t_{MCH} or t_{MCL} (bits 5 and 4 = "00"), $2t_{MCH}$ or $2t_{MCL}$ (bits 5 and 4 = "01"), $4t_{MCH}$ or $4t_{MCL}$ (bits 5 and 4 = "10").

Fig. 9. Other timing

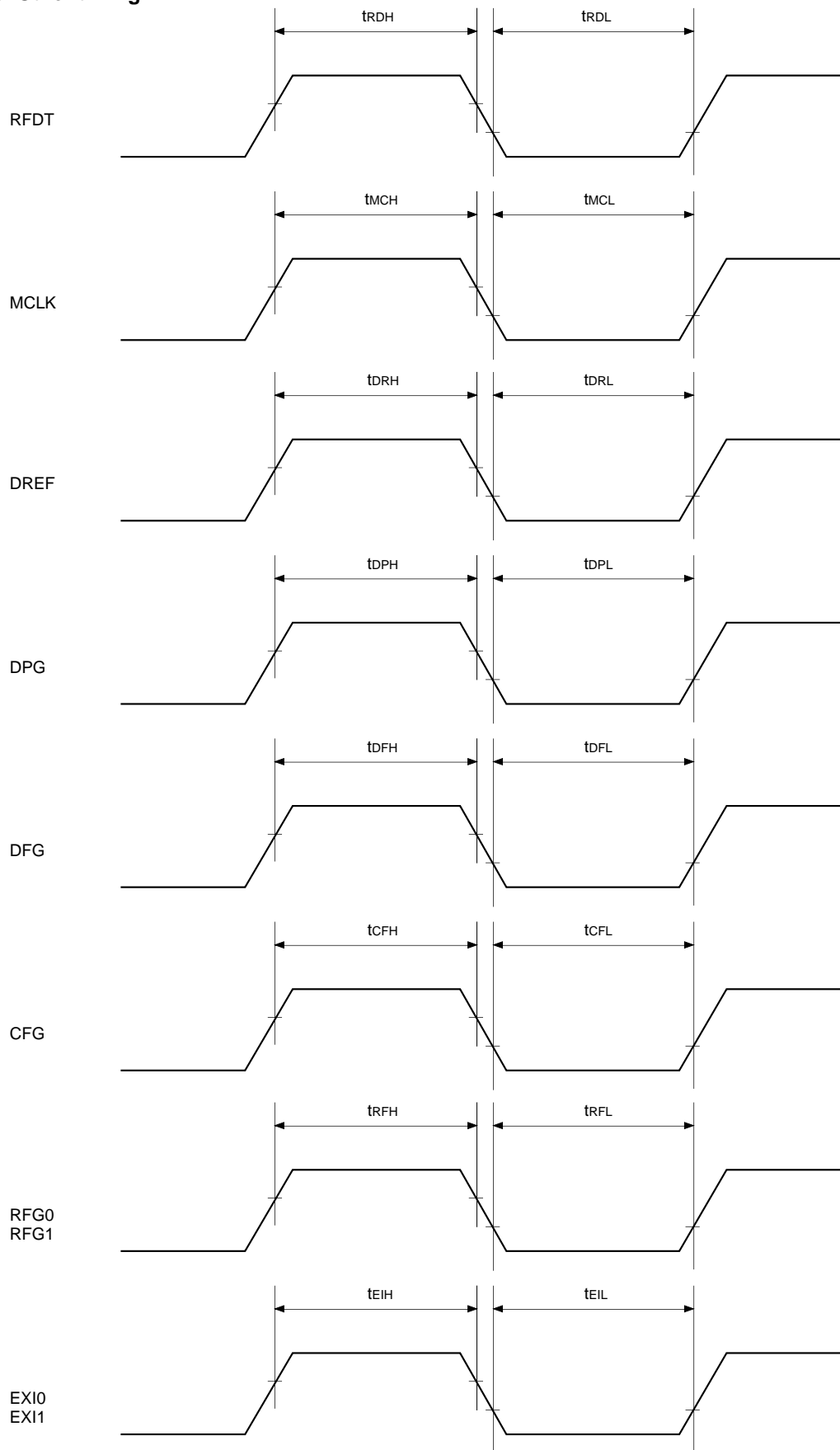

(7) Buffer amplifier function

($T_a = -10$ to $+75^\circ\text{C}$, $V_{DD} = 4.5$ to 5.5V , $V_{SS} = 0\text{V}$)

Item	Symbol	Pin	Condition	Min.	Max.	Unit
Buffer amplifier input voltage* (Peak to peak value)	V_{APP}	RFDT	When inputting 400kHz sine wave on Fig. 10 circuit.	2.0	$V_{DD} + 0.3$	V

* When buffer amplifier input circuit format of RFDT pin is selected with option.

Fig. 10.

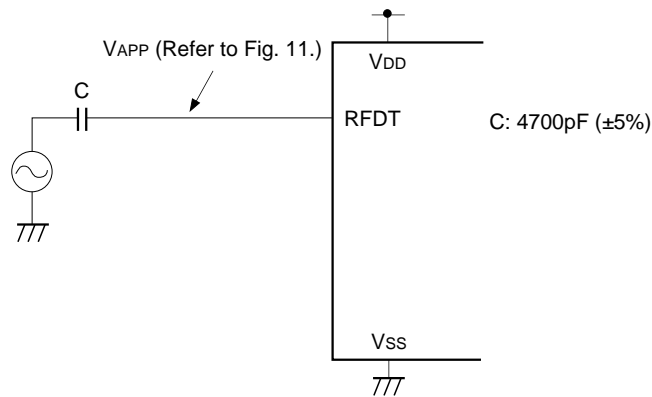

Note) V_{APP} waveform indicates the range like Fig. 11. When composed by circuits other than Fig. 10. (when DC bias does not become $V_{DD}/2$), it should not exceed $V_{DD} + 0.3$ (V) and -0.3 (V) ($V_{SS} = 0\text{V}$).

Fig. 11.

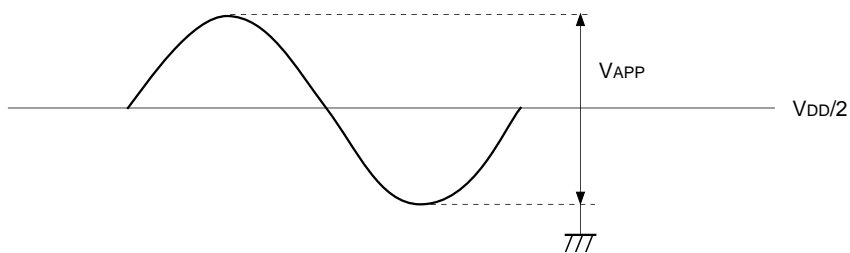

SUPPLEMENT

Fig. 12. SPC700 series recommended oscillation circuit

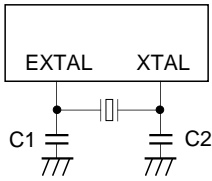

Manufacturer	Model	Frequency f (MHz)	C1, C2 (pF)
RIVER ELETEC CO., LTD.	HC-49/U-03	6.00	12
		8.00	12
		12.000	10

Mask option table

Item	Contents	
	Reset pin pull-up resistor	Non-existent
Power on reset circuit	Non-existent	Existent
Input circuit format*	CMOS Schmitt	TTL Schmitt
	Buffer amplifier	Normal input

* On PG0/EXI0 pin to PG7/RFG1 pin and PK1/MCLK pin, the input circuit format of CMOS schmitt or TTL schmitt can be selected to every pin.

On PK0/RFDI pin, buffer amplifier or normal input circuit format can be selected.

Package Outline

Unit: mm

100PIN LQFP (PLASTIC)

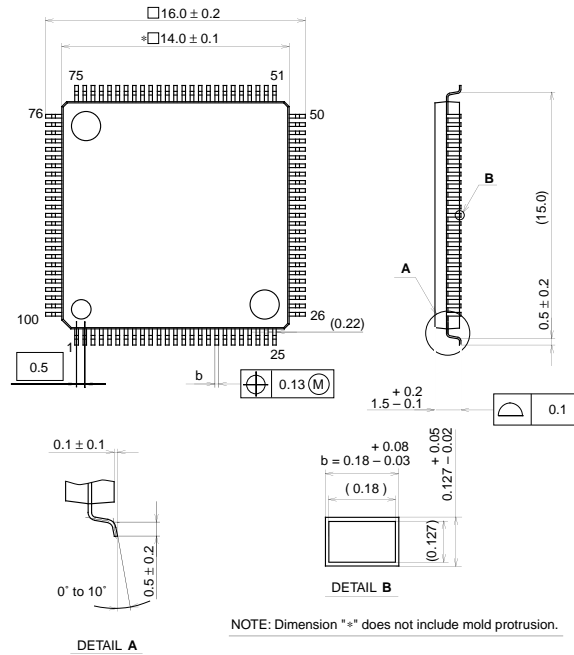

SONY CODE	LQFP-100P-L01
EIAJ CODE	P-LQFP100-14x14-0.5
JEDEC CODE	

PACKAGE STRUCTURE

PACKAGE MATERIAL	EPOXY RESIN
LEAD TREATMENT	SOLDER PLATING
LEAD MATERIAL	42 / COPPER ALLOY
PACKAGE MASS	0.7g

100PIN LQFP (PLASTIC)

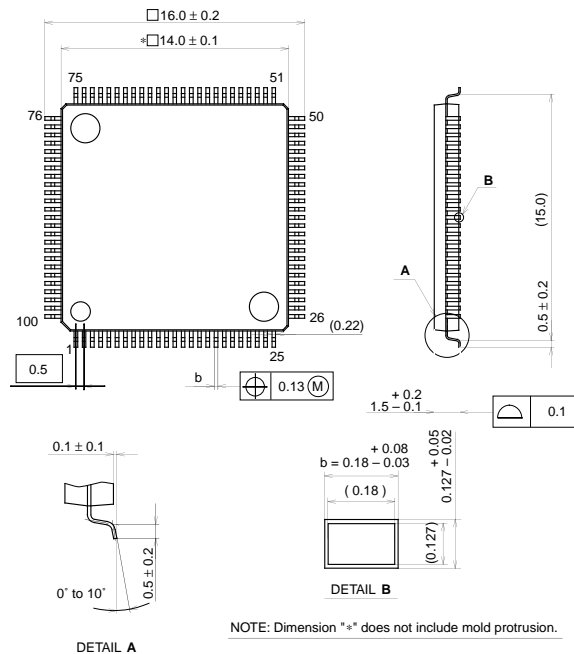

SONY CODE	LQFP-100P-L01
EIAJ CODE	P-LQFP100-14x14-0.5
JEDEC CODE	

PACKAGE STRUCTURE

PACKAGE MATERIAL	EPOXY RESIN
LEAD TREATMENT	SOLDER PLATING
LEAD MATERIAL	42 / COPPER ALLOY
PACKAGE MASS	0.7g

LEAD SPECIFICATIONS

ITEM	SPEC.
LEAD MATERIAL	ALLOY 42
LEAD TREATMENT	Sn-Bi 2.5%
LEAD TREATMENT THICKNESS	5-18 μ m



LittleDiode supplies new, hard to find or obsolete electronic components and semiconductors all over the world.

With over two million different components listed you are sure to find the part you need.

Feel free to visit us today at our online store:

LittleDiode.com

Looking forward to providing you with the best possible service.