

CMOS 8-bit Single Chip Microcomputer

Description

The CXP874P60 is a CMOS 8-bit microcomputer which consists of A/D converter, serial interface (2ch independently), timer/counter, time base timer, vector interruption, high precision timing pattern generation circuit (PPG 2ch independently, RTG 2ch independently), PWM generator, general purpose prescaler, PWM for tuner, VCR vertical sync separation circuit and the measuring circuit which measure signals of capstan FG and drum FG/PG and other servo systems, as well as basic configurations like 8-bit CPU, PROM, RAM and I/O port. They are integrated into a single chip.

Also CXP874P60 provides power on reset function, sleep/stop function which enables to lower power consumption .

CXP874P60 is the PROM-incorporated version of the CXP87452/87460 with built-in mask ROM. This provides the additional feature of being able to write directly into the program. Thus, it is most suitable for evaluation use during system development and for small-quantity production.

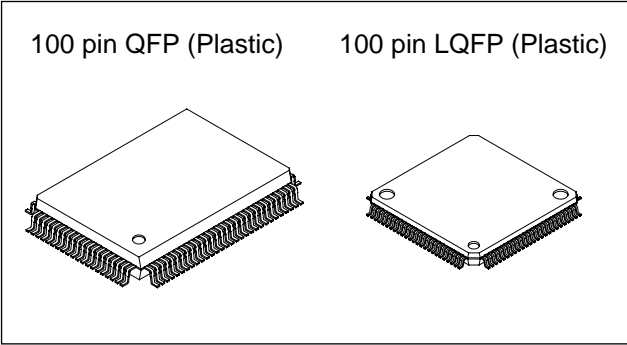

Structure

Silicon gate CMOS IC

Features

- A wide instruction set (213 instructions) which cover various types of data
 - 16-bit arithmetic instruction/multiplication and division instructions/boolean bit operation instruction
- Minimum instruction cycle
 - During operation 333ns/12MHz (3.0 to 5.5V)
 - During operation 250ns/16MHz (4.5 to 5.5V)
- Incorporated PROM capacity 60K bytes
- Incorporated RAM capacity 1568 bytes
- Peripheral functions
 - A/D converter 8-bit, 12-channel, successive approximation system (Conversion time: 20μs/16MHz)
 - Serial interface Incorporated buffer RAM (1 to 32 bytes auto transfer) 1-channel
Incorporated 8-bit and 8-stage FIFO (1 to 8 bytes auto transfer) 1-channel
 - Timer 8-bit timer, 8-bit timer/counter, 19-bit time base timer
 - High precision timing pattern generator PPG 19 pins 32-stage programmable
PPG 10 pins 21-stage programmable
RTG 5 pins 2-channel
 - PWM/DA gate output PWM 12-bit, 2-channel (Repetitive frequency 62.5kHz/16MHz)
DA gate pulse 12-bit, 4-channel
Capstan FG, Drum FG/PG, CTL input
 - Servo input control
 - VSYNC separator
 - FRC capture unit
 - PWM output Incorporated 26-bit and 8-stage FIFO
14-bit, 1-channel
 - General purpose prescaler 10-bit (System clock asynchronous)
 - Pulse cycle measurement circuit
- Interruption 18 factors, 14 vectors, multi-interruption possible
- Standby mode SLEEP/STOP
- Package 100-pin plastic QFP/LQFP

Sony reserves the right to change products and specifications without prior notice. This information does not convey any license by any implication or otherwise under any patents or other right. Application circuits shown, if any, are typical examples illustrating the operation of the devices. Sony cannot assume responsibility for any problems arising out of the use of these circuits.

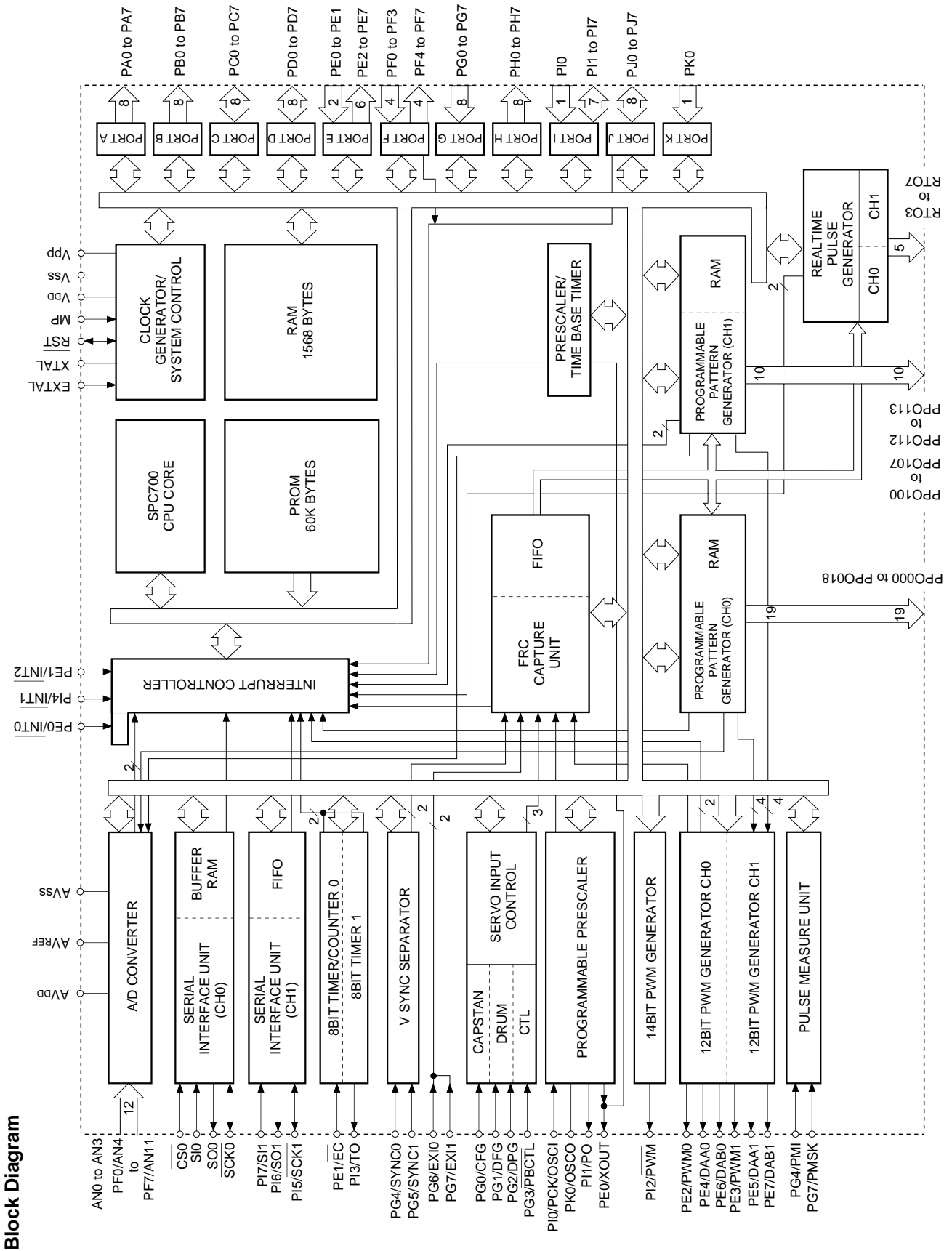

Block Diagram

Pin Configuration 1 (Top View) 100-pin QFP Package

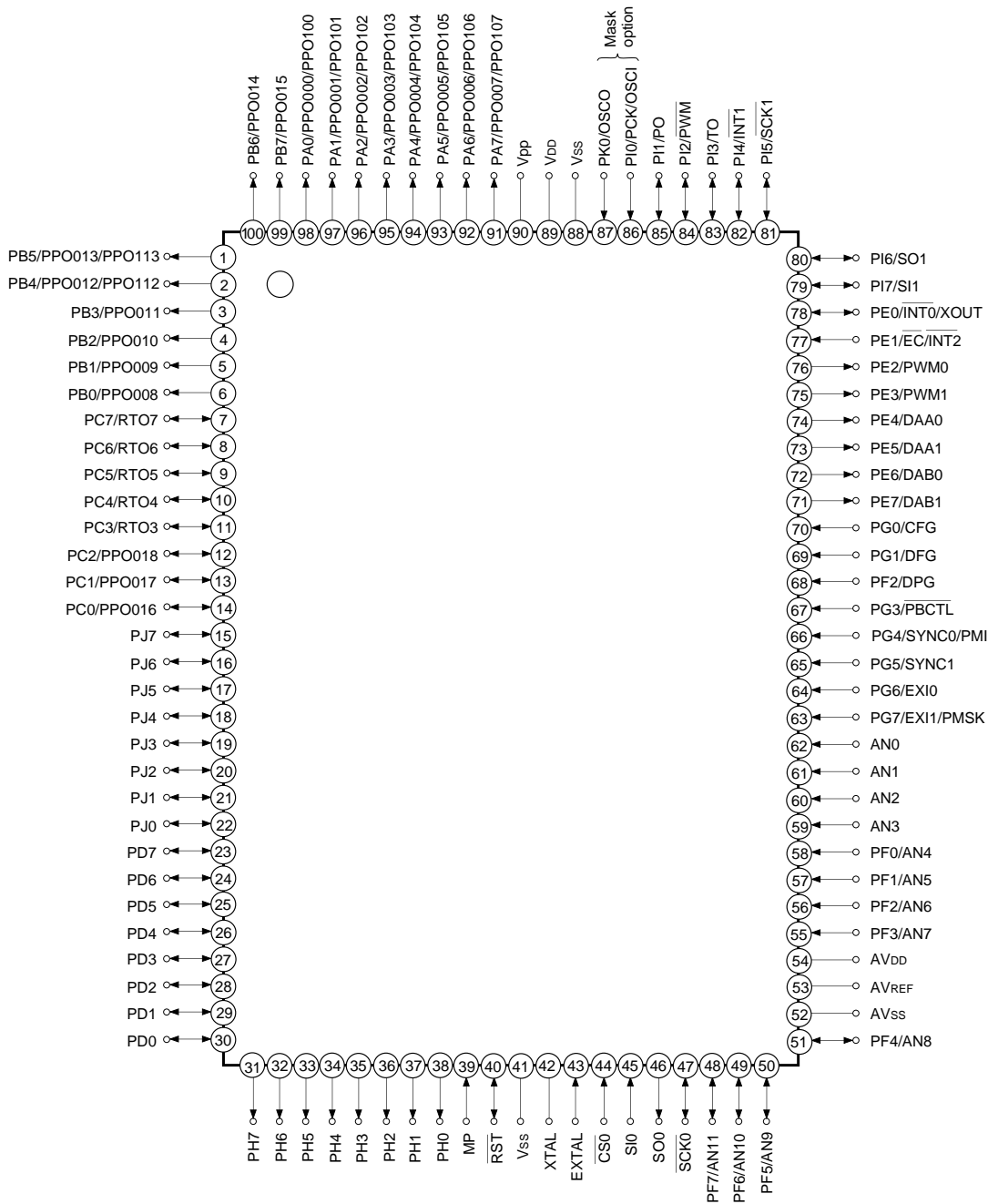

- Note)** 1. Vpp (Pin 90) is always connected to VDD.
 2. Vss (Pins 41 and 88) are both connected to GND.

Pin Configuration 2 (Top View) 100-pin LQFP Package

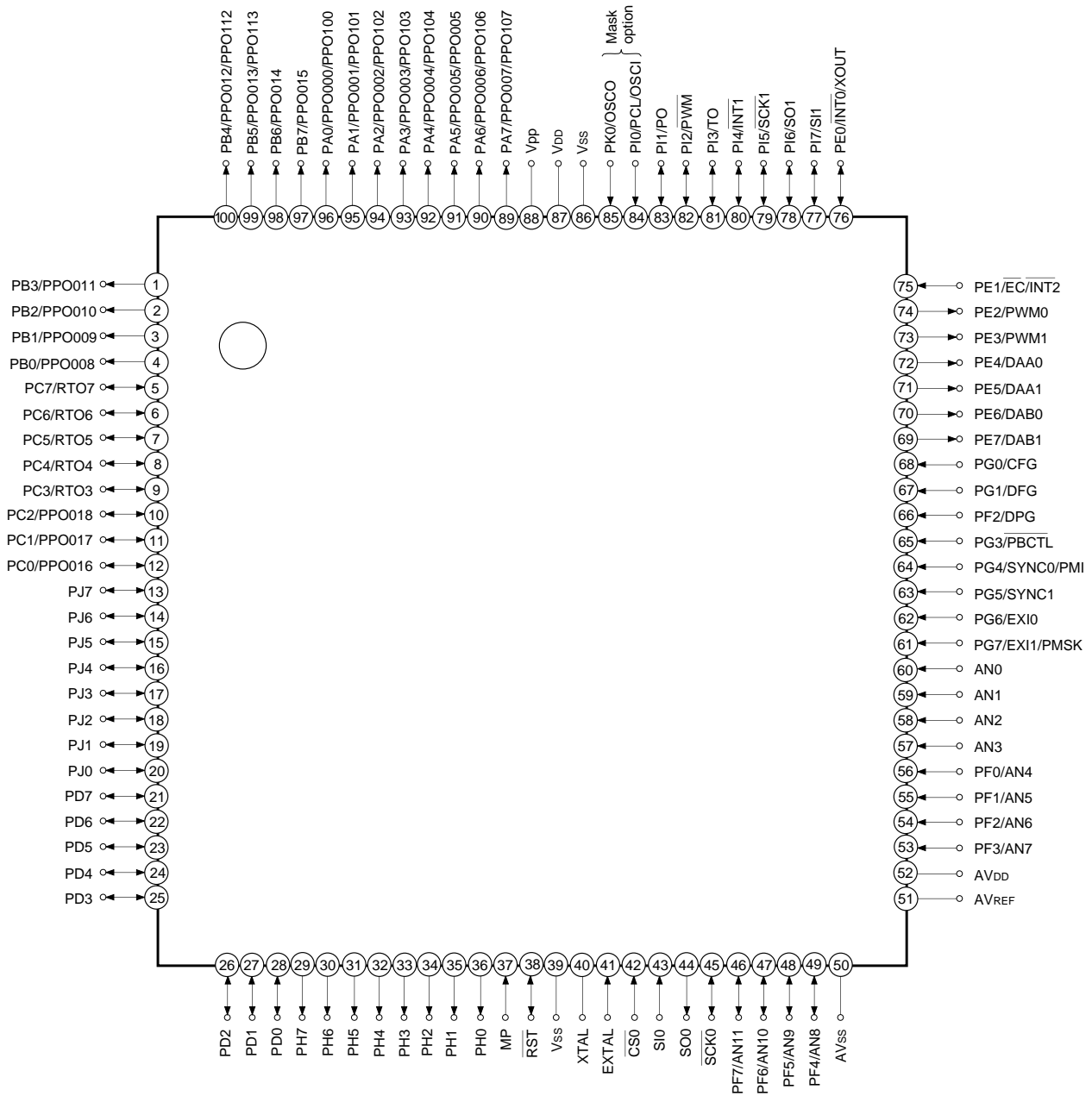

- Note)**
1. Vpp (Pin 88) is always connected to VDD.
 2. Vss (Pins 39 and 86) are both connected to GND.

Pin Description

Symbol	I/O	Description		
PA0/PPO000 /PPO100 to PA7/PPO007 /PPO107	Output/ Real time output	(Port A) 8-bit output port. Data is gated with PPO0 and PPO1 contents by OR-gate and they are output. (8 pins)	Programmable pattern generator (PPG0, PPG1) output. Functions as high precision real time pulse output port. (PPG0 19 pins) (PPG1 10 pins)	
PB0/PPO008 to PB7/PPO015	Output/ Real time output	(Port B) 8-bit output port. Data is gated with PPO0 and PPO1 contents by OR-gate and they are output. (8 pins)		
PC0/PPO016 to PC2/PPO018	I/O/ Real time output	(Port C) 8-bit I/O port. Enables to specify I/O by bit unit. Data is gated with PPO or RTO contents by OR-gate and they are output. (8 pins)		
PC3/RTO3 to PC7/RTO7	I/O/ Real time output		Real time pulse generator (RTG) output. Functions as high precision real time pulse output port. (5 pins)	
PD0 to PD7	I/O	(Port D) 8-bit I/O port. Enable to specify I/O by 4-bit unit. Enables to drive 12mA sink current. (During 5V±0.5V operation) (8 pins)		
PE0/ $\overline{\text{INT0}}$ /XOUT	Input/Input/Output	(Port E) 8-bit port. Lower 2 bits are input port and upper 6 bits are output port. (8 pins)	Input pin to request external interruption. Active when falling edge.	1/2 dividing clock output of XTAL or OSCO.
PE1/ $\overline{\text{EC}}$ / $\overline{\text{INT2}}$	Input/Input/Input		External event input pin for timer/counter.	Input pin to request external interruption. Active when falling edge.
PE2/PWM0	Output/Output		PWM output pins. (2 pins)	
PE3/PWM1	Output/Output			
PE4/DAA0	Output/Output			
PE5/DAA1	Output/Output			
PE6/DAB0	Output/Output		DA gate pulse output pins. (4 pins)	
PE7/DAB1	Output/Output			
AN0 to AN3	Input	Analog input pins to A/D converter. (12 pins)		
PF0/AN4 to PF3/AN7	Input/Input	(Port F) Lower 4 bits are input port and upper 4 bits are output port. Lower 4 bits also serve as standby release input pin. (8 pins)		
PF4/AN8 to PF7/AN11	Output/Input			
$\overline{\text{SCK0}}$	I/O	Serial clock (CH0) I/O pin.		
SO0	Output	Serial data (CH0) output pin.		
SI0	Input	Serial data (CH0) input pin.		
$\overline{\text{CS0}}$	Input	Serial chip select (CH0) input pin.		

Symbol	I/O	Description		
PG0/CFG	Input/Input	(Port G) 8-bit input port. (8 pins)	Capstan FG input pin.	
PG1/DFG	Input/Input		Drum FG input pin.	
PG2/DPG	Input/Input		Drum PG input pin.	
PG3/PBCTL	Input/Input		Playback CTL pulse input pin.	
PG4/SYNC0 /PMI	Input/Input/Input		Composite sync signal input pin.	Measuring pulse signal input pin of pulse cycle measuring unit.
PG5/SYNC1	Input/Input			
PG6/EXI0	Input/Input		External input pin to FRC capture unit.	
PG7/EXI1/ PMSK	Input/Input/Input			Measuring enable signal input pin of pulse cycle measuring unit.
PH0 to PH7	Output	(Port H) 8-bit output port; large current, N-ch open drain output. (8 pins)		
PI0/PCK /OSCI	Input/Input/Input	(Port I) Lower 1 bit is input port (mask option) and upper 7 bits are I/O port. I/O port can be specified by bit unit. (8 pins)	External clock input pin of general purpose prescaler.	Connecting pin of crystal oscillation circuit for general purpose prescaler. (Mask option)
PI1/PO	I/O/Output		General purpose prescaler output pin.	
PI2/PWM	I/O/Output		14-bit PWM output pin.	
PI3/TO	I/O/Output		Timer/counter, output pin. (duty=50%)	
PI4/INT1	I/O/Input		Input pin to request external interruption. Active when falling edge.	
PI5/SCK1	I/O/I/O		Serial clock (CH1) I/O pin.	
PI6/SO1	I/O/Output		Serial data (CH1) output pin.	
PI7/SI1	I/O/Input		Serial data (CH1) input pin.	
PJ0 to PJ7	I/O	(Port J) 8-bit I/O port. Function as standby release input can be specified by bit unit. I/O can be specified by bit unit.		

Symbol	I/O	Description	
PK0/OSCO	Input/Output	Input port. (Mask option)	Connecting pin of crystal oscillation circuit for general purpose prescaler. (Mask option)
EXTAL	Input	Connecting pin of crystal oscillator for system clock. When supplying the external clock, input the external clock to EXTAL pin and input opposite phase clock to XTAL pin.	
XTAL	Output		
$\overline{\text{RST}}$	I/O	System reset pin of active "L" level. $\overline{\text{RST}}$ pin is I/O pin, which output "L" level by incorporated power on reset function when power on. (Mask option)	
MP	Input	Microprocessor mode input pin. Always connect to GND.	
AV _{DD}		Positive power supply pin of A/D converter.	
AV _{REF}	Input	Reference voltage input pin of A/D converter.	
AV _{SS}		GND pin of A/D converter.	
V _{DD}		Positive power supply pin.	
V _{pp}		Positive power supply pin for built-in PROM writing. Connect to V _{DD} for normal operation.	
V _{SS}		GND pin. Connect two V _{SS} pins to GND.	

Input/Output Circuit Format for Pins

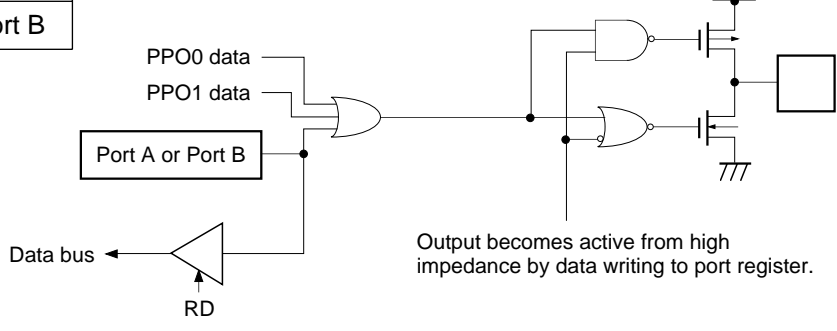
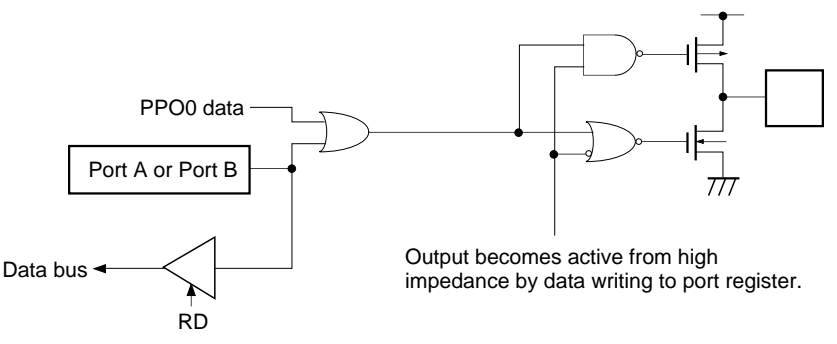
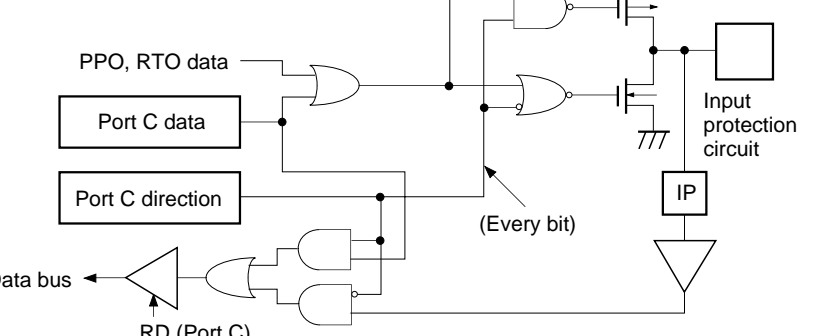
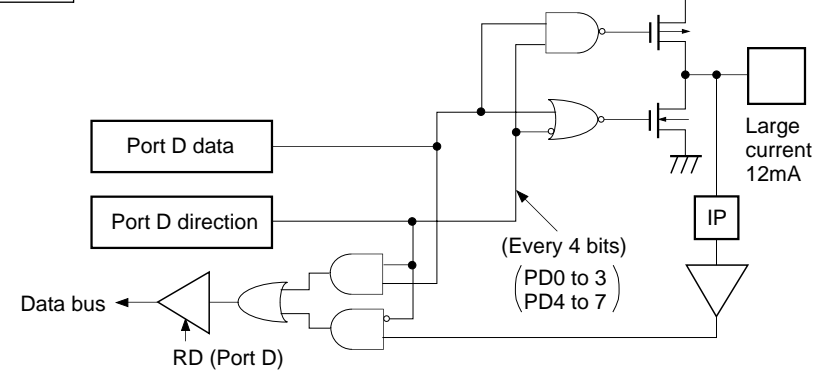
Pin	Circuit format	When reset
PA0/PPO000 /PPO100 to PA7/PPO007 /PPO107 PB4/PPO012 /PPO112 to PB5/PPO013 /PPO113 10 pins	<p>Port A</p> <p>Port B</p>  <p>PPO0 data PPO1 data</p> <p>Port A or Port B</p> <p>Data bus ← RD</p> <p>Output becomes active from high impedance by data writing to port register.</p>	Hi-Z
PB0/PPO008 to PB3/PPO011 PB6/PPO014 to PB7/PPO015 6 pins	<p>Port B</p>  <p>PPO0 data</p> <p>Port A or Port B</p> <p>Data bus ← RD</p> <p>Output becomes active from high impedance by data writing to port register.</p>	Hi-Z
PC0/PPO016 to PC2/PPO018 PC3/RTO3 to PC7/RTO7 8 pins	<p>Port C</p>  <p>PPO, RTO data</p> <p>Port C data</p> <p>Port C direction</p> <p>Data bus ← RD (Port C)</p> <p>(Every bit)</p> <p>Input protection circuit IP</p>	Hi-Z
PD0 to PD7 8 pins	<p>Port D</p>  <p>Port D data</p> <p>Port D direction</p> <p>Data bus ← RD (Port D)</p> <p>(Every 4 bits) (PD0 to 3) (PD4 to 7)</p> <p>Large current 12mA IP</p>	Hi-Z

Pin	Circuit format	When reset
<p>PE1/$\overline{\text{EC}}/\overline{\text{INT2}}$</p> <p>1 pin</p>	<p>Port E</p> <p>Schmitt input</p> <p>IP</p> <p>RD (Port E)</p> <p>Data bus</p>	Hi-Z
<p>PE0/$\overline{\text{INT0}}/\overline{\text{XOUT}}$</p> <p>1 pin</p>	<p>Port E</p> <p>PS1</p> <p>OSCO</p> <p>1/2</p> <p>Port E function select register</p> <p>MPX</p> <p>Data bus</p> <p>RD (Port E)</p> <p>To interruption circuit</p> <p>IP</p>	Hi-Z
<p>PE2/PWM0 PE3/PWM1 PE4/DAA0 PE5/DAA1</p> <p>4 pins</p>	<p>Port E</p> <p>DA gate output or PWM output</p> <p>Hi-Z control</p> <p>Port E data</p> <p>Port E function select register</p> <p>MPX</p> <p>Data bus</p> <p>RD (Port E)</p>	Hi-Z
<p>PE6/DAB0 PE7/DAB1</p> <p>2 pins</p>	<p>Port E</p> <p>DA gate output</p> <p>Hi-Z control</p> <p>Port E data</p> <p>Port E function select register</p> <p>MPX</p> <p>Data bus</p> <p>RD (Port E)</p>	H level

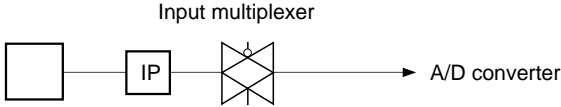
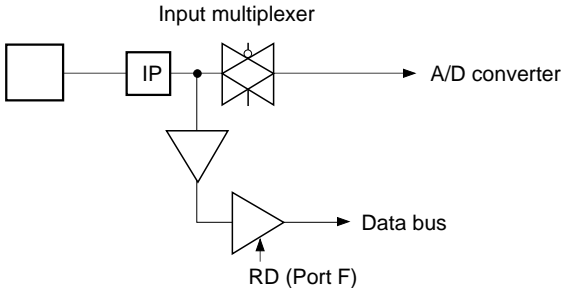
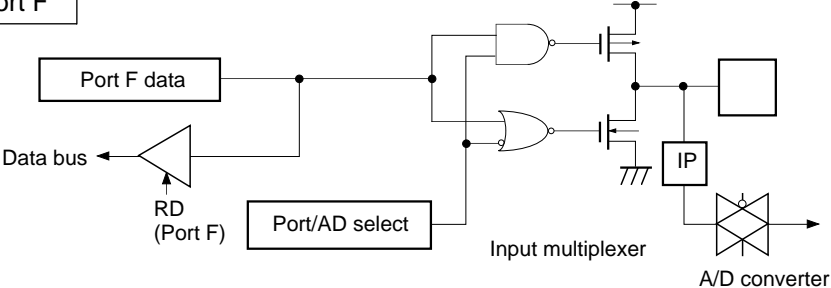
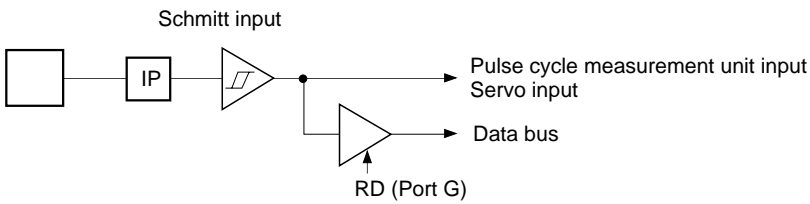
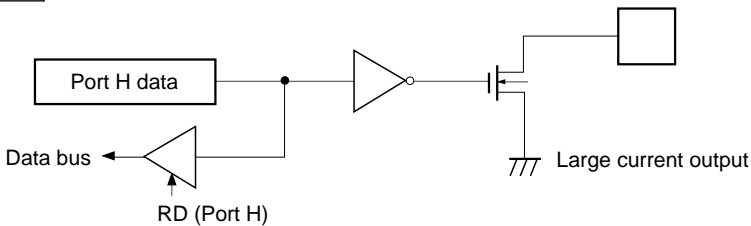
Pin	Circuit format	When reset
AN0 to AN3 4 pins		Hi-Z
PF0/AN4 to PF3/AN7 4 pins	<p>Port F</p> 	Hi-Z
PF4/AN8 to PF7/AN11 4 pins	<p>Port F</p> 	Hi-Z
PG0/CFG PG1/DFG PG2/DPG PG3/PBCTL PG4/SYNC0/PMI PG5/SYNC1 PG6/EXI0 PG7/EXI1/PMSK 8 pins	<p>Port G</p>  <p>Note) For PG4 and PG5 input format, there are CMOS schmitt input and TTL schmitt input with product.</p>	Hi-Z
PH0 to PH7 8 pins	<p>Port H</p> 	Hi-Z

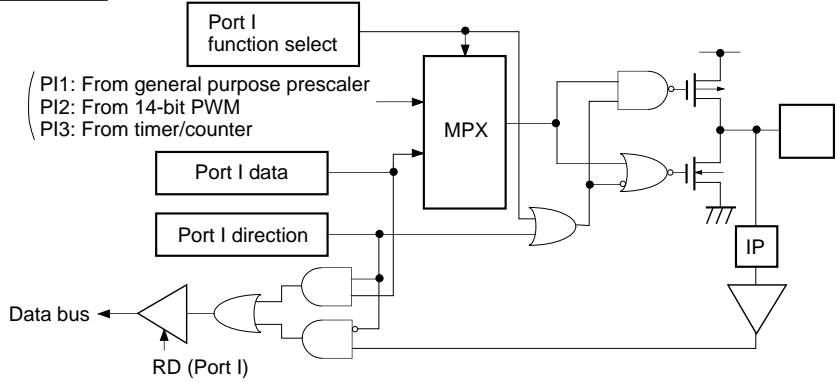
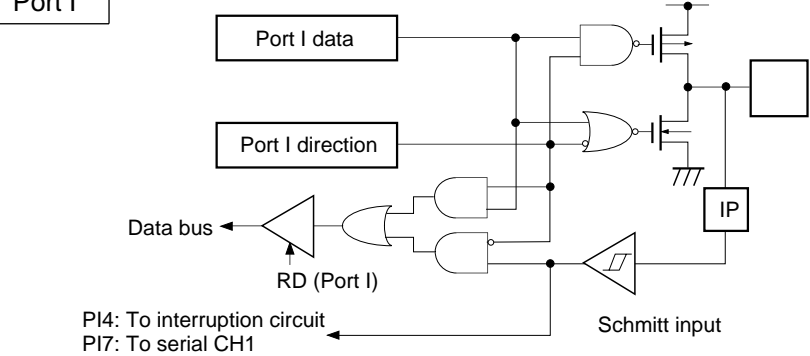
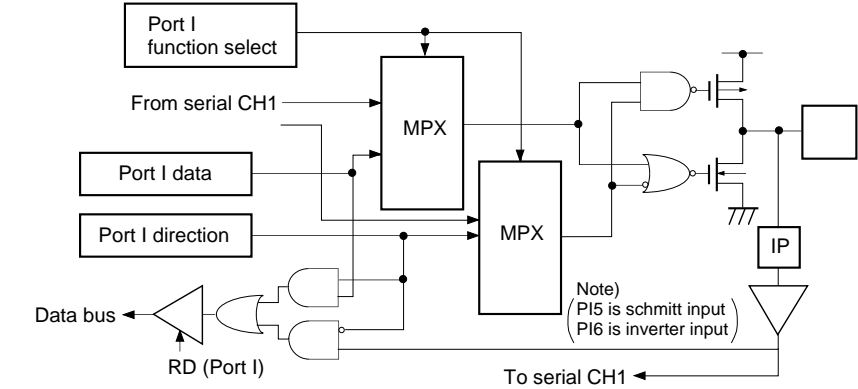
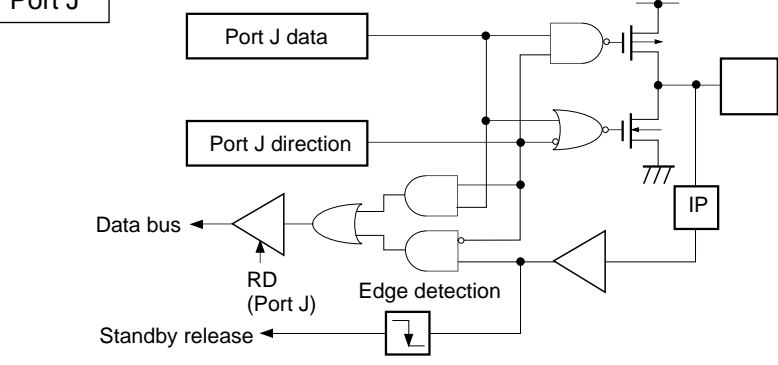
Pin	Circuit format	When reset
<p>P11/PO P12/PWM P13/TO</p> <p>3 pins</p>	<p>Port I</p>  <p>Port I function select</p> <p>(P11: From general purpose prescaler P12: From 14-bit PWM P13: From timer/counter)</p> <p>Port I data</p> <p>Port I direction</p> <p>Data bus</p> <p>RD (Port I)</p> <p>IP</p>	<p>Hi-Z</p>
<p>P14/$\overline{\text{INT1}}$ P17/S11</p> <p>2 pins</p>	<p>Port I</p>  <p>Port I data</p> <p>Port I direction</p> <p>Data bus</p> <p>RD (Port I)</p> <p>IP</p> <p>Schmitt input</p> <p>P14: To interruption circuit P17: To serial CH1</p>	<p>Hi-Z</p>
<p>P15/$\overline{\text{SCK1}}$ P16/SO1</p> <p>2 pins</p>	<p>Port I</p>  <p>Port I function select</p> <p>From serial CH1</p> <p>Port I data</p> <p>Port I direction</p> <p>Data bus</p> <p>RD (Port I)</p> <p>IP</p> <p>Note) P15 is schmitt input P16 is inverter input</p> <p>To serial CH1</p>	<p>Hi-Z</p>
<p>PJ0 to PJ7</p> <p>8 pins</p>	<p>Port J</p>  <p>Port J data</p> <p>Port J direction</p> <p>Data bus</p> <p>RD (Port J)</p> <p>IP</p> <p>Edge detection</p> <p>Standby release</p>	<p>Hi-Z</p>

Pin	Circuit format	When reset
CS0 SIO 2 pins	<p>Schmitt input</p>	Hi-Z
SO0 1 pin		Hi-Z
SCK0 1 pin		Hi-Z
EXTAL XTAL 2 pins	<ul style="list-style-type: none"> • Shows the circuit composition during oscillation. • Feedback resistor is removed during stop. 	Oscillation
RST 1 pin		L level
MP 1 pin		Hi-Z
PI0/PCK/OSCI PK0/OSCO 2 pins	<div style="display: flex; flex-direction: column;"> <div style="margin-bottom: 10px;"> <p>Port I Port K</p> <p style="text-align: center;">Fig. 1</p> </div> <div> <p style="text-align: center;">Fig. 2</p> </div> </div> <p>Note) Circuit format of Fig. 1 or Fig. 2 can be selected with mask option.</p>	<p>Oscillation</p> <p>Hi-Z</p>

Absolute Maximum Ratings

(V_{SS}=0V)

Item	Symbol	Rating	Unit	Remarks
Power supply voltage	V _{DD}	-0.3 to +7.0	V	
	V _{pp}	-0.3 to +13.0	V	Incorporated PROM
	AV _{DD}	AV _{SS} to +7.0* ¹	V	
	AV _{SS}	-0.3 to +0.3	V	
Input voltage	V _{IN}	-0.3 to +7.0* ²	V	
Output voltage	V _{OUT}	-0.3 to +7.0* ²	V	
High level output current	I _{OH}	-5	mA	
High level total output current	∑I _{OH}	-50	mA	Total of output pins
Low level output current	I _{OL}	15	mA	Other than large current output pins: per pin
	I _{OLC}	20	mA	Large current output pin* ³ : per pin
Low level total output current	∑I _{OL}	130	mA	Total of output pins
Operating temperature	T _{opr}	-10 to +75	°C	
Storage temperature	T _{stg}	-55 to +150	°C	
Allowable power dissipation	P _D	600	mW	QFP
		380		LQFP

*¹ AV_{DD} and V_{DD} should be set to a same voltage.

*² V_{IN} and V_{OUT} should not exceed V_{DD} + 0.3V. ($\overline{CS0}$, $\overline{SI0}$, PG and PH excluded.)

*³ The large current operation transistors are the N-CH transistors of the PD and PH ports.

Note) Usage exceeding absolute maximum ratings may permanently impair the LSI. Normal operation should better take place under the recommended operating conditions. Exceeding those conditions may adversely affect the reliability of the LSI.

Recommended Operating Conditions

(V_{SS} = 0V)

Item	Symbol	Min.	Max.	Unit	Remarks
Power supply voltage	V _{DD}	3.0	5.5	V	Guaranteed range during high speed mode (1/2 dividing clock) operation
		2.7	5.5	V	Guaranteed range during low speed mode (1/16 dividing clock) operation
		2.5	5.5	V	Guaranteed data hold operation range during STOP
	V _{pp}	V _{pp} = V _{DD}		V	*9
Analog power supply	AV _{DD}	3.0	5.5	V	*1
High level input voltage	V _{IH}	0.7V _{DD}	V _{DD}	V	*2
	V _{IHS}	0.8V _{DD}	V _{DD}	V	CMOS schmitt input*3 and PE0/ $\overline{\text{INT0}}$ pins
			5.5	V	CMOS schmitt input*4
	V _{IHTS}	2.2	5.5	V	TTL schmitt input*5, *8
	V _{IHEX}	V _{DD} - 0.4	V _{DD} + 0.3	V	EXTAL pin*6, *8
V _{DD} - 0.2			V _{DD} + 0.2	V	EXTAL pin*6, *7
Low level input voltage	V _{IL}	0	0.3V _{DD}	V	*2, *8
			0.2V _{DD}	V	*2, *7
	V _{ILS}	0	0.2V _{DD}	V	CMOS schmitt input*3, *4 and PE0/ $\overline{\text{INT0}}$ pins
	V _{ILTS}	0	0.8	V	TTL schmitt input*5, *8
	V _{ILEX}	-0.3	0.4	V	EXTAL pin*6, *8
0.2			V	EXTAL pin*6, *7	
Operating temperature	Topr	-10	+75	°C	

*1 AV_{DD} and V_{DD} should be set to a same voltage.

*2 Normal input port (each pin of $\overline{\text{PC}}$, $\overline{\text{PD}}$, $\overline{\text{PF0}}$ to $\overline{\text{PF3}}$, $\overline{\text{PI}}$ $\overline{\text{PJ}}$, and $\overline{\text{PK}}$), MP pin.

*3 Each pin of $\overline{\text{SCK0}}$, $\overline{\text{RST}}$, $\overline{\text{PE1/EC/INT2}}$, $\overline{\text{PI1/PO}}$, $\overline{\text{PI4/INT1}}$, $\overline{\text{PI5/SCK1}}$ and $\overline{\text{PI7/SI1}}$.

*4 Each pin of $\overline{\text{CS0}}$, $\overline{\text{SI0}}$, and $\overline{\text{PG}}$ (for $\overline{\text{PG4}}$ and $\overline{\text{PG5}}$, when CMOS schmitt input is selected for the product.)

*5 Each pin of $\overline{\text{PG4}}$ and $\overline{\text{PG5}}$ (When TTL schmitt input is selected for the product)

*6 It specifies only when the external clock is input.

*7 In case of 3.0 to 3.6V supply voltage (V_{DD}).

*8 In case of 4.5 to 5.5V supply voltage (V_{DD}).

*9 V_{pp} and V_{DD} should be set to a same voltage.

Electrical Characteristics

DC Characteristics

Supply voltage (V_{DD}) 4.5 to 5.5V

(T_a = -10 to +75°C, V_{SS} = 0V)

Item	Symbol	Pin	Condition	Min.	Typ.	Max.	Unit
High level output voltage	V _{OH}	PA to PE, PF4 to PF7, PH (V _{OL} only)	V _{DD} = 4.5V, I _{OH} = -0.5mA	4.0			V
			V _{DD} = 4.5V, I _{OH} = -1.2mA	3.5			V
Low level output voltage	V _{OL}	PI1 to PI7, PJ, SO, SCK, RST (V _{OL} only)	V _{DD} = 4.5V, I _{OL} = 1.8mA			0.4	V
			V _{DD} = 4.5V, I _{OL} = 3.6mA			0.6	V
			PD, PH	V _{DD} = 4.5V, I _{OL} = 12.0mA			1.5
Input current	I _{IHE}	EXTAL	V _{DD} = 5.5V, V _{IH} = 5.5V	0.5		40	μA
	I _{ILE}		V _{DD} = 5.5V, V _{IL} = 0.4V	-0.5		-40	μA
	I _{ILR}		RST	V _{DD} = 5.5V, V _{IL} = 0.4V	-1.5		-400
I/O leakage current	I _{Iz}	PA to PK, MP, AN0 to AN3, CS, SI, SO, SCK	V _{DD} = 5.5V, V _I = 0, 5.5V			±10	μA
Supply current*1	I _{DD1}	V _{DD}	Crystal oscillation (C ₁ = C ₂ = 15pF) of 16MHz		28	50	mA
	I _{DDS1}		V _{DD} = 5V ± 0.5V*2		1.7	8.0	mA
			SLEEP mode	V _{DD} = 5V ± 0.5V			
I _{DDS3}	STOP mode	V _{DD} = 5.5V			30	μA	
Input capacity	C _{IN}	Other than V _{DD} , V _{SS} , AV _{DD} , and AV _{SS} pins	Clock 1MHz 0V other than the measured pins		10	20	pF

*1 When entire output pins are open.

*2 When setting upper 2 bits (CPU clock selection) of clock control register CLC (address: 00FEH) to "00" and operating in high speed mode (1/2 dividing clock).

Supply voltage (V_{DD}) 3.0 to 3.6V

(T_a = -10 to +75°C, V_{SS} = 0V)

Item	Symbol	Pin	Condition	Min.	Typ.	Max.	Unit
High level output voltage	V _{OH}	PA to PE, PF4 to PF7, PH (V _{OL} only)	V _{DD} = 3.0V, I _{OH} = -0.15mA	2.7			V
			V _{DD} = 3.0V, I _{OH} = -0.5mA	2.3			V
Low level output voltage	V _{OL}	PI1 to PI7, PJ, SO, SCK, RST (V _{OL} only)	V _{DD} = 3.0V, I _{OL} = 1.2mA			0.3	V
			V _{DD} = 3.0V, I _{OL} = 1.6mA			0.5	V
		PD, PH	V _{DD} = 3.0V, I _{OL} = 5.0mA			1.0	V
Input current	I _{IHE}	EXTAL	V _{DD} = 3.6V, V _{IH} = 3.6V	0.3		20	μA
	I _{IIE}		V _{DD} = 3.6V, V _{IL} = 0.3V	-0.3		-20	μA
	I _{ILR}	RST	V _{DD} = 3.6V, V _{IL} = 0.3V	-0.9		-200	μA
I/O leakage current	I _{Iz}	PA to PK, MP, AN0 to AN3, CS, SI, SO, SCK	V _{DD} = 5.5V, V _I = 0, 5.5V			±10	μA
Supply current*1	I _{DD2}	V _{DD}	Crystal oscillation (C ₁ = C ₂ = 15pF) of 12MHz		12	30	mA
	I _{DDS2}		V _{DD} = 3.3V ± 0.3V*2		0.8	2.5	mA
			SLEEP mode	V _{DD} = 3.3V ± 0.3V			
I _{DDS3}	STOP mode	V _{DD} = 5.5V			30	μA	
Input capacity	C _{IN}	Other than V _{DD} , V _{SS} , AV _{DD} , and AV _{SS} pins	Clock 1MHz 0V other than the measured pins		10	20	pF

*1 When entire output pins are open.

*2 When setting upper 2 bits (CPU clock selection) of clock control register CLC (address: 00FEH) to "00" and operating in high speed mode (1/2 dividing clock).

AC Characteristics

(1) Clock timing

(Ta = -10 to +75°C, VDD = 3.0 to 5.5V, VSS = 0V)

Item	Symbol	Pin	Condition	Min.	Max.	Unit	
System clock frequency	fc	XTAL EXTAL	Fig. 1, Fig. 2	VDD = 4.5 to 5.5V	1	16	MHz
					1	12	
System clock input pulse width	tXL, tXH	XTAL EXTAL	Fig. 1, Fig. 2 (External clock drive)	VDD = 4.5 to 5.5V	28		ns
					37.5		
System clock input rising and falling times	tCR, tCF	XTAL EXTAL	Fig. 1, Fig. 2 (External clock drive)		200	ns	
Event count clock input pulse width	tEL, tEH	PE1/EC	Fig. 3	tsys × 4*		ns	
Event count clock input rising and falling times	tER, tEF	PE1/EC	Fig. 3		20	ms	

* tsys indicates three values according to the contents of the clock control register (address; 00FEH) upper 2 bits (CPU clock selection).

tsys [ns] = 2000/fc (Upper 2 bits = "00"), 4000/fc (Upper 2 bits = "01"), 16000/fc (Upper 2 bits = "11")

Fig. 1. Clock timing

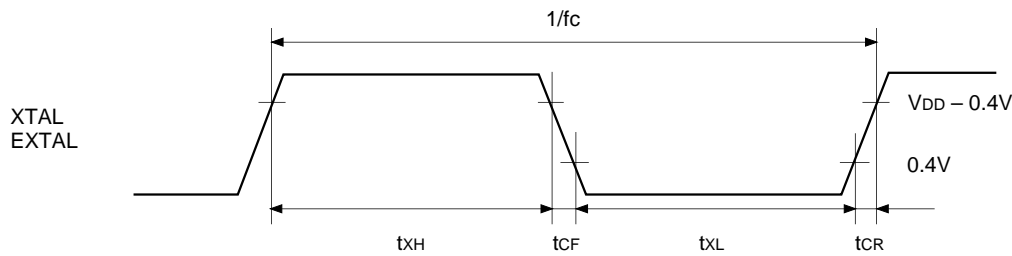

Fig. 2. Clock applied condition

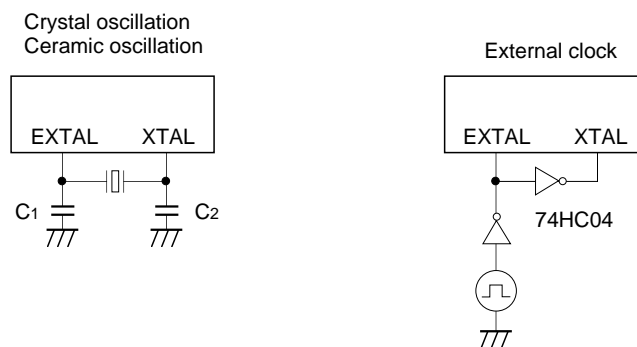
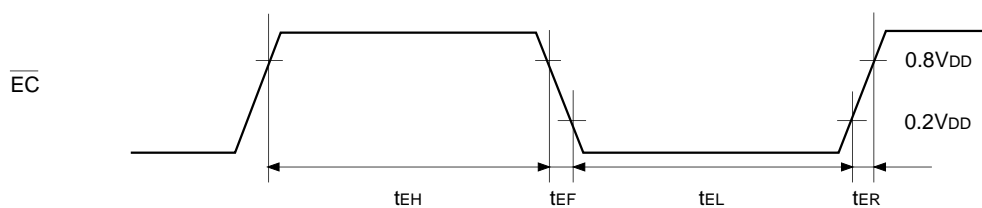

Fig. 3. Event count clock timing



(2) Serial transfer (CH0)

(Ta = -10 to +75°C, VDD = 4.5 to 5.5V, VSS = 0V)

Item	Symbol	Pin	Condition	Min.	Max.	Unit
$\overline{CS} \downarrow \rightarrow \overline{SCK}$ delay time	t _{DCSK}	$\overline{SCK0}$	Chip select transfer mode (SCK = output mode)		t _{sys} + 200	ns
$\overline{CS} \uparrow \rightarrow \overline{SCK}$ floating delay time	t _{DCSKF}	$\overline{SCK0}$	Chip select transfer mode (SCK = output mode)		t _{sys} + 200	ns
$\overline{CS} \downarrow \rightarrow SO$ delay time	t _{DCSO}	SO0	Chip select transfer mode		t _{sys} + 200	ns
$\overline{CS} \downarrow \rightarrow SO$ floating delay time	t _{DCSOF}	SO0	Chip select transfer mode		t _{sys} + 200	ns
\overline{CS} high level width	t _{WHCS}	$\overline{CS0}$	Chip select transfer mode	t _{sys} + 200		ns
\overline{SCK} cycle time	t _{KCY}	$\overline{SCK0}$	Input mode	2t _{sys} + 200		ns
			Output mode	8000/fc		ns
\overline{SCK} high and low level widths	t _{KH} t _{KL}	$\overline{SCK0}$	Input mode	t _{sys} + 100		ns
			Output mode	8000/fc - 100		ns
SI input setup time (against $\overline{SCK} \uparrow$)	t _{SIK}	SI0	\overline{SCK} input mode	-t _{sys} + 100		ns
			\overline{SCK} output mode	200		ns
SI input hold time (against $\overline{SCK} \uparrow$)	t _{KSI}	SI0	\overline{SCK} input mode	2t _{sys} + 100		ns
			\overline{SCK} output mode	100		ns
$\overline{SCK} \downarrow \rightarrow SO$ delay time	t _{KSO}	SO0	\overline{SCK} input mode		2t _{sys} + 200	ns
			\overline{SCK} output mode		100	ns

Note 1) t_{sys} indicates three values according to the contents of the clock control register (address; 00FEH) upper 2 bits (CPU clock selection).

t_{sys} [ns] = 2000/fc (Upper 2 bits = "00"), 4000/fc (Upper 2 bits = "01"), 16000/fc (Upper 2 bits = "11")

Note 2) \overline{CS} , \overline{SCK} , SI and SO means each pin of $\overline{CS} \rightarrow \overline{CS0}$, $\overline{SCK} \rightarrow \overline{SCK0}$, SI \rightarrow SI0, and SO \rightarrow SO0 respectively.

Note 3) The load of \overline{SCK} output mode and SO output delay time is 50pF + 1TTL.

Serial transfer (CH0)

(Ta = -10 to +75°C, V_{DD} = 3.0 to 3.6V, V_{SS} = 0V)

Item	Symbol	Pin	Condition	Min.	Max.	Unit
$\overline{\text{CS}} \downarrow \rightarrow \overline{\text{SCK}}$ delay time	t _{DCSK}	$\overline{\text{SCK0}}$	Chip select transfer mode (SCK = output mode)		t _{sys} + 250	ns
$\overline{\text{CS}} \uparrow \rightarrow \overline{\text{SCK}}$ floating delay time	t _{DCSKF}	$\overline{\text{SCK0}}$	Chip select transfer mode (SCK = output mode)		t _{sys} + 200	ns
$\overline{\text{CS}} \downarrow \rightarrow \text{SO}$ delay time	t _{DCSO}	SO0	Chip select transfer mode		t _{sys} + 250	ns
$\overline{\text{CS}} \downarrow \rightarrow \text{SO}$ floating delay time	t _{DCSOF}	SO0	Chip select transfer mode		t _{sys} + 200	ns
$\overline{\text{CS}}$ high level width	t _{WHCS}	$\overline{\text{CS0}}$	Chip select transfer mode	t _{sys} + 200		ns
$\overline{\text{SCK}}$ cycle time	t _{KCY}	$\overline{\text{SCK0}}$	Input mode	2t _{sys} + 200		ns
			Output mode	8000/fc		ns
$\overline{\text{SCK}}$ high and low level widths	t _{KH} t _{KL}	$\overline{\text{SCK0}}$	Input mode	t _{sys} + 100		ns
			Output mode	8000/fc - 150		ns
SI input setup time (against $\overline{\text{SCK}} \uparrow$)	t _{SIK}	SI0	$\overline{\text{SCK}}$ input mode	-t _{sys} + 100		ns
			$\overline{\text{SCK}}$ output mode	200		ns
SI input hold time (against $\overline{\text{SCK}} \uparrow$)	t _{KSI}	SI0	$\overline{\text{SCK}}$ input mode	2t _{sys} + 100		ns
			$\overline{\text{SCK}}$ output mode	100		ns
$\overline{\text{SCK}} \downarrow \rightarrow \text{SO}$ delay time	t _{KSO}	SO0	$\overline{\text{SCK}}$ input mode		2t _{sys} + 250	ns
			$\overline{\text{SCK}}$ output mode		125	ns

Note 1) t_{sys} indicates three values according to the contents of the clock control register (address; 00FEH) upper 2 bits (CPU clock selection).

t_{sys} [ns] = 2000/fc (Upper 2 bits = "00"), 4000/fc (Upper 2 bits = "01"), 16000/fc (Upper 2 bits = "11")

Note 2) $\overline{\text{CS}}$, $\overline{\text{SCK}}$, SI and SO means each pin of $\overline{\text{CS}} \rightarrow \overline{\text{CS0}}$, $\overline{\text{SCK}} \rightarrow \overline{\text{SCK0}}$, SI \rightarrow SI0, and SO \rightarrow SO0 respectively.

Note 3) The load of $\overline{\text{SCK}}$ output mode and SO output delay time is 50pF.

Fig. 4. Serial transfer timing (CH0)

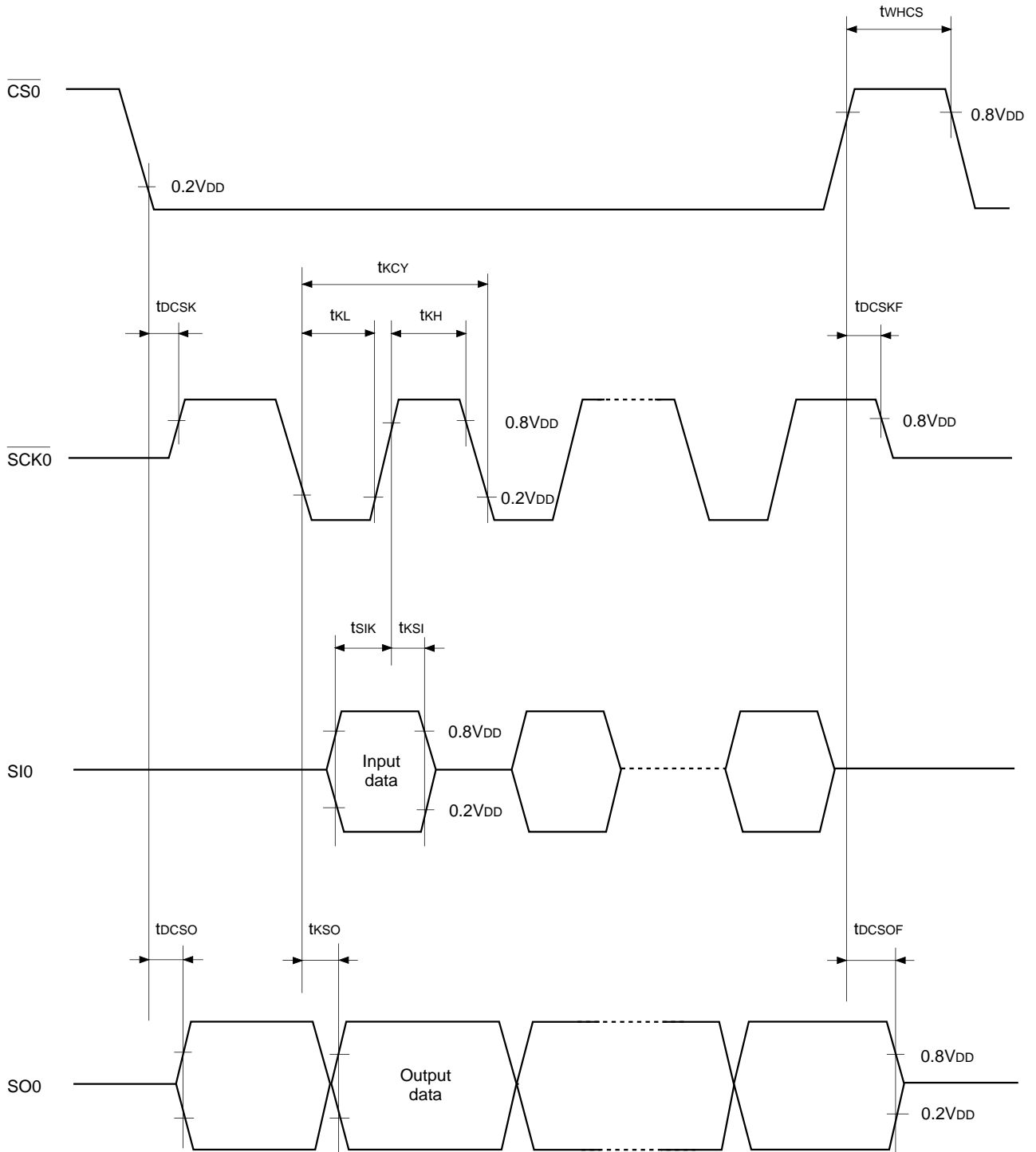

Serial transfer (CH1) (SIO mode)

(Ta = -10 to +75°C, V_{DD} = 4.5 to 5.5V, V_{SS} = 0V)

Item	Symbol	Pin	Condition	Min.	Max.	Unit
$\overline{\text{SCK1}}$ cycle time	t_{KCY}	SCK1	Input mode	$2t_{\text{sys}} + 200$		ns
			Output mode	$16000/f_c$		ns
$\overline{\text{SCK1}}$ high and low level widths	t_{KH} t_{KL}	SCK1	Input mode	$t_{\text{sys}} + 100$		ns
			Output mode	$8000/f_c - 100$		ns
SI1 input setup time (against $\overline{\text{SCK1}}$ ↑)	t_{SIK}	SI1	$\overline{\text{SCK1}}$ input mode	100		ns
			$\overline{\text{SCK1}}$ output mode	200		ns
SI1 input hold time (against $\overline{\text{SCK1}}$ ↑)	t_{KSI}	SI1	$\overline{\text{SCK1}}$ input mode	$t_{\text{sys}} + 200$		ns
			$\overline{\text{SCK1}}$ output mode	100		ns
SCK1 ↓ → SO1 delay time	t_{KSO}	SO1	$\overline{\text{SCK1}}$ input mode		$t_{\text{sys}} + 200$	ns
			$\overline{\text{SCK1}}$ output mode		100	ns

Note 1) t_{sys} indicates three values according to the contents of the clock control register (address; 00FE_H) upper 2 bits (CPU clock selection).

t_{sys} [ns] = 2000/ f_c (Upper 2 bits = "00"), 4000/ f_c (Upper 2 bits = "01"), 16000/ f_c (Upper 2 bits = "11")

Note 2) The load of $\overline{\text{SCK1}}$ output mode and SO1 output delay time is 50pF + 1TTL.

Serial transfer (CH1) (SIO mode)

(Ta = -10 to +75°C, V_{DD} = 3.0 to 3.6V, V_{SS} = 0V)

Item	Symbol	Pin	Condition	Min.	Max.	Unit
$\overline{\text{SCK1}}$ cycle time	t_{KCY}	SCK1	Input mode	$2t_{\text{sys}} + 200$		ns
			Output mode	$16000/f_c$		ns
$\overline{\text{SCK1}}$ high and low level widths	t_{KH} t_{KL}	SCK1	Input mode	$t_{\text{sys}} + 100$		ns
			Output mode	$8000/f_c - 150$		ns
SI1 input setup time (against $\overline{\text{SCK1}}$ ↑)	t_{SIK}	SI1	$\overline{\text{SCK1}}$ input mode	100		ns
			$\overline{\text{SCK1}}$ output mode	200		ns
SI1 input hold time (against $\overline{\text{SCK1}}$ ↑)	t_{KSI}	SI1	$\overline{\text{SCK1}}$ input mode	$t_{\text{sys}} + 200$		ns
			$\overline{\text{SCK1}}$ output mode	100		ns
SCK1 ↓ → SO1 delay time	t_{KSO}	SO1	$\overline{\text{SCK1}}$ input mode		$t_{\text{sys}} + 250$	ns
			$\overline{\text{SCK1}}$ output mode		125	ns

Note 1) t_{sys} indicates three values according to the contents of the clock control register (address; 00FE_H) upper 2 bits (CPU clock selection).

t_{sys} [ns] = 2000/ f_c (Upper 2 bits = "00"), 4000/ f_c (Upper 2 bits = "01"), 16000/ f_c (Upper 2 bits = "11")

Note 2) The load of $\overline{\text{SCK1}}$ output mode and SO1 output delay time is 50pF.

Fig. 5. Serial transfer CH1 timing (SIO mode)

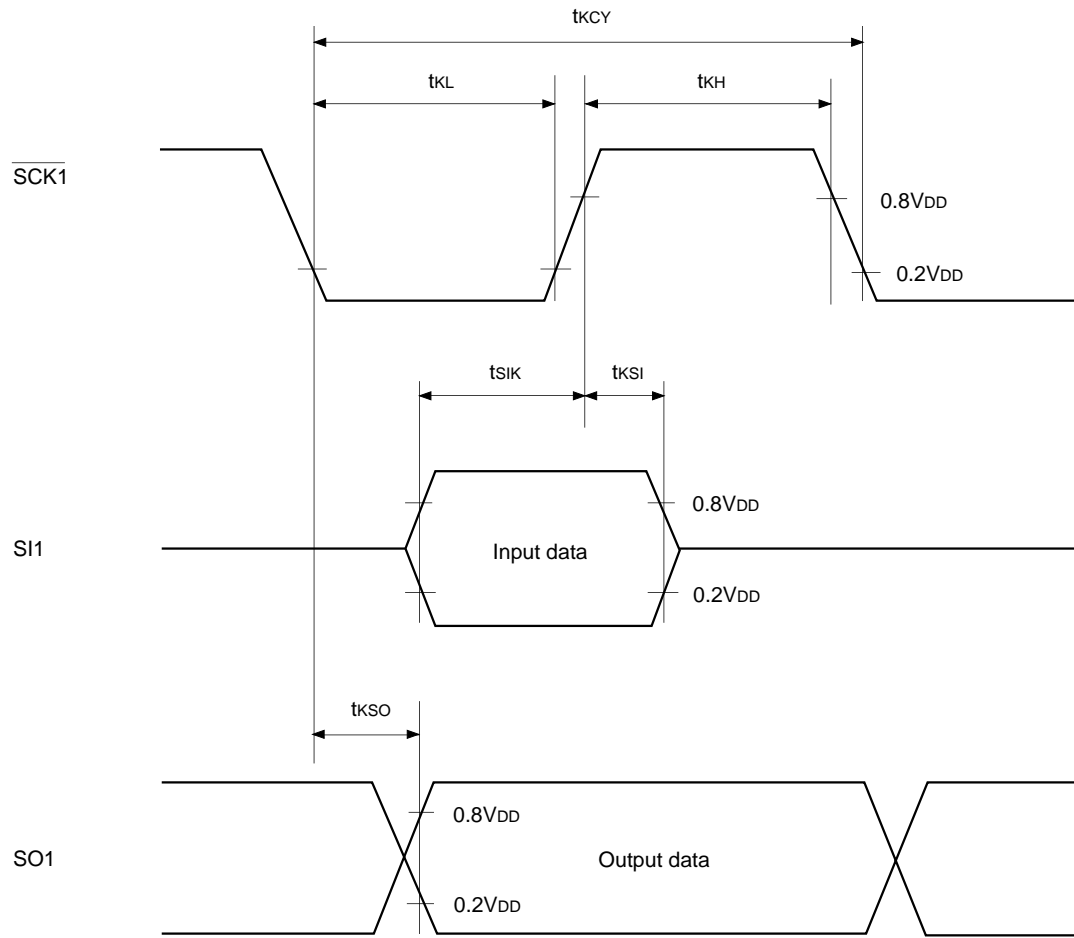

Serial transfer (CH1) (Special mode) (Ta = -10 to +75°C, VDD = 4.5 to 5.5V, VSS = 0V)

Item	Symbol	Pin	Condition	Min.	Typ.	Max.	Unit
SO1 cycle time	t _{LCY}	SO1 SI1	Note 1)		104		μs
SI1 data setup time	t _{LSU}	SI1		2			μs
SI1 data hold time	t _{LHD}	SI1		2			μs

Note 1) t_{LCY} specifies only serial mode register (CH1) (SIOM1: Address 01FAH) lower 2 bits (SO1 clock selection) has been set at 104μs.

Note 2) The load of SO1 pin is 50pF + 1TTL.

Serial transfer (CH1) (Special mode) (Ta = -10 to +75°C, VDD = 3.0 to 3.6V, VSS = 0V)

Item	Symbol	Pin	Condition	Min.	Typ.	Max.	Unit
SO1 cycle time	t _{LCY}	SO1 SI1	Note 1)		104		μs
SI1 data setup time	t _{LSU}	SI1		2			μs
SI1 data hold time	t _{LHD}	SI1		2			μs

Note 1) t_{LCY} specifies only serial mode register (CH1) (SIOM1: Address 01FAH) lower 2 bits (SO1 clock selection) has been set at 104μs.

Note 2) The load of SO1 pin is 50pF.

Fig. 6. Serial transfer CH1 timing (Special mode)

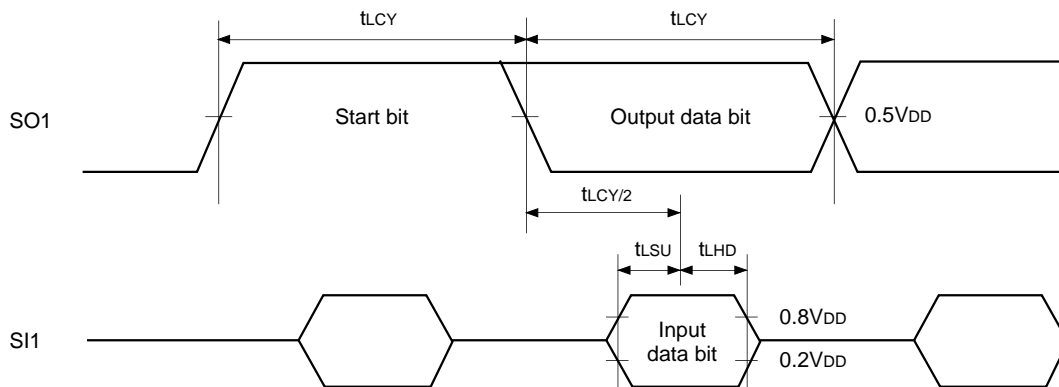

(3) A/D converter characteristics (Ta = -10 to +75°C, VDD = AVDD = 4.5 to 5.5V, AVREF = 4.0 to AVDD, VSS = AVSS = 0V)

Item	Symbol	Pin	Condition	Min.	Typ.	Max.	Unit
Resolution						8	Bits
Linearity error			Only for A/D converter operation Ta = 25°C VDD = AVDD = AVREF = 5.0V VSS = AVSS = 0V			±1	LSB
Absolute error						±2	LSB
Conversion time	tCONV			160/fADC			µs
Sampling time	tSAMP			12/fADC			µs
Reference input voltage	VREF	AVREF	VDD = AVDD = 4.5 to 5.5V	AVDD - 0.5		AVDD	V
Analog input voltage	VIAN	AN0 to AN11		0		AVREF	V
AVREF current	IREF	AVREF	Operating mode AVREF = 4.0 to 5.5V		0.6	1.0	mA
			SLEEP mode STOP mode			10	µA

A/D converter characteristics (Ta = -10 to +75°C, VDD = AVDD = 3.0 to 3.6V, AVREF = 2.7 to AVDD, VSS = AVSS = 0V)

Item	Symbol	Pin	Condition	Min.	Typ.	Max.	Unit
Resolution						8	Bits
Linearity error			Only for A/D converter operation Ta = 25°C VDD = AVDD = AVREF = 3.3V VSS = AVSS = 0V			±1	LSB
Absolute error						±2	LSB
Conversion time	tCONV			160/fADC			µs
Sampling time	tSAMP			12/fADC			µs
Reference input voltage	VREF	AVREF	VDD = AVDD = 3.0 to 3.6V	AVDD - 0.3		AVDD	V
Analog input voltage	VIAN	AN0 to AN11		0		AVREF	V
AVREF current	IREF	AVREF	Operating mode AVREF = 2.7 to 3.6V		0.4	0.7	mA
			SLEEP mode STOP mode			10	µA

Fig. 7. Definitions of A/D converter terms

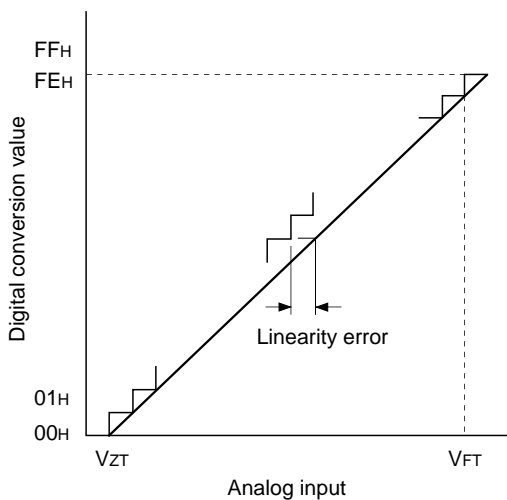

* The value of fADC is as follows by selecting ADC operation clock (MSC: Address 01FFH bit 0).
 When PS2 is selected, fADC = fc/2
 When PS1 is selected, fADC = fc

(4) Interruption, reset input

($T_a = -10$ to $+75^\circ\text{C}$, $V_{DD} = 3.0$ to 5.5V , $V_{SS} = 0\text{V}$)

Item	Symbol	Pin	Condition	Min.	Max.	Unit
External interruption high and low level widths	t_{IH} t_{IL}	$\overline{\text{INT0}}$ $\overline{\text{INT1}}$ $\overline{\text{INT2}}$ PJ0 to PJ7		1		μs
Reset input low level width	t_{RSL}	$\overline{\text{RST}}$		$32/f_c$		μs

Fig. 8. Interruption input timing

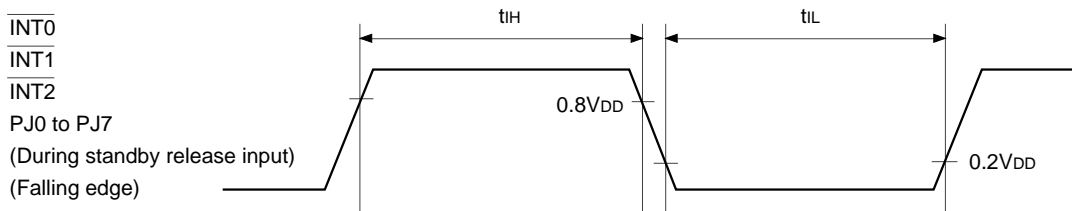
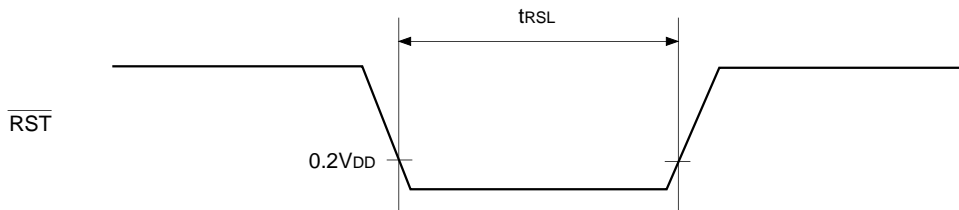

Fig. 9. Reset input timing



(5) Power on reset

Power on reset*

($T_a = -10$ to $+75^\circ\text{C}$, $V_{DD} = 3.0$ to 5.5V , $V_{SS} = 0\text{V}$)

Item	Symbol	Pin	Condition	Min.	Max.	Unit
Power supply rising edge	t_R	V_{DD}	Power on reset	0.05	30	ms
Power supply cut-off time	t_{OFF}		Repetitive power on reset	1		ms

* Specifies only when power on reset function is selected.

Fig. 10. Power on reset

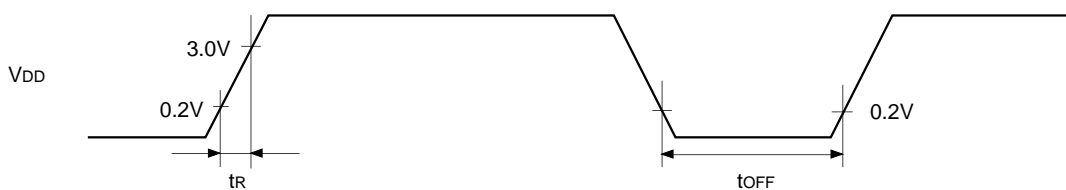

The power supply should rise smoothly.

(6) General purpose prescaler

($T_a = -10$ to $+75^\circ\text{C}$, $V_{DD} = 4.5$ to 5.5V , $V_{SS} = 0\text{V}$)

Item	Symbol	Pin	Condition	Min.	Typ.	Max.	Unit
External clock input frequency	f_{PCK}	PCK				12	MHz
External clock input pulse width	t_{WH}, t_{WL}	PCK		33			ns
External clock input rising and falling times	t_R, t_F	PCK				200	ns
Prescaler output delay time (against PCK \uparrow)	t_{PLH}	PO	External clock input PCK $t_R = t_F = 6\text{ns}$		80	130	ns
	t_{PHL}				60	100	ns
Prescaler output rising and falling times	t_{TLH}	PO	External clock input PCK $t_R = t_F = 6\text{ns}$		50	100	ns
	t_{THL}				20	40	ns

Note) The load of PO pin is 50pF.

General purpose prescaler

($T_a = -10$ to $+75^\circ\text{C}$, $V_{DD} = 3.0$ to 3.6V , $V_{SS} = 0\text{V}$)

Item	Symbol	Pin	Condition	Min.	Typ.	Max.	Unit
External clock input frequency	f_{PCK}	PCK				12	MHz
External clock input pulse width	t_{WH}, t_{WL}	PCK		33			ns
External clock input rising and falling times	t_R, t_F	PCK				200	ns
Prescaler output delay time (against PCK \uparrow)	t_{PLH}	PO	External clock input PCK $t_R = t_F = 6\text{ns}$		130	220	ns
	t_{PHL}				90	150	ns
Prescaler output rising and falling times	t_{TLH}	PO	External clock input PCK $t_R = t_F = 6\text{ns}$		100	280	ns
	t_{THL}				30	70	ns

Note) The load of PO pin is 50pF.

Fig. 11. General purpose prescaler timing

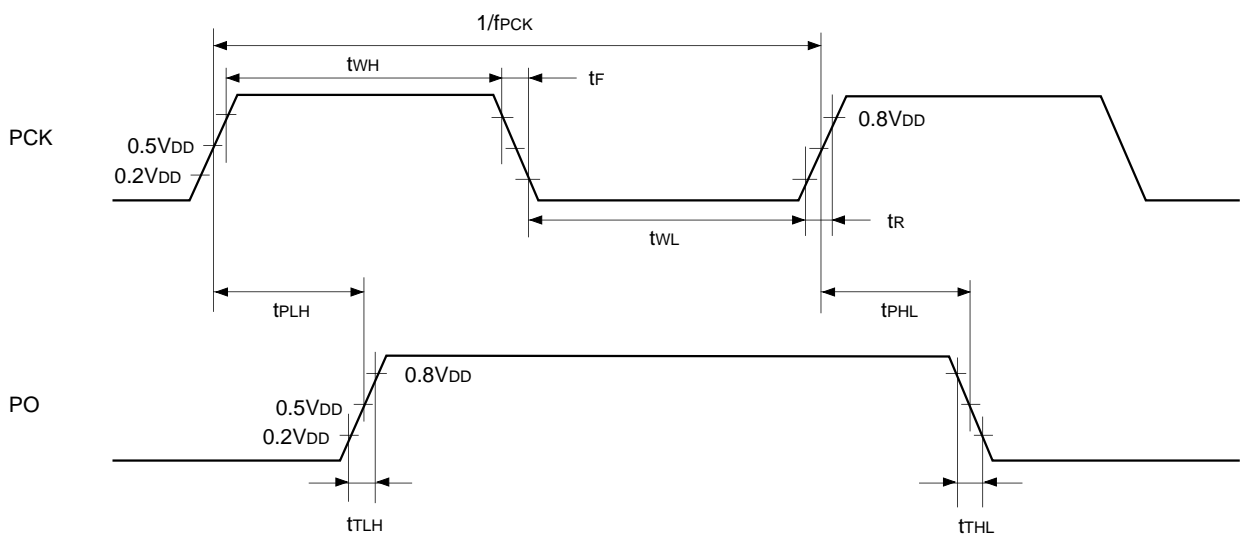

(7) Others

(Ta = -10 to +75°C, VDD = 3.0 to 5.5V, VSS = 0V)

Item	Symbol	Pin	Condition	Min.	Max.	Unit
CFG input high and low level widths	t _{CFH} t _{CFL}	CFG		t _{FRC} × 24 + 200		ns
DFG input high and low level widths	t _{DFH} t _{DFL}	DFG		t _{FRC} × 8 + 200		ns
DPG minimum pulse width	t _{DPW}	DPG		50		ns
DPG minimum removal time	t _{rem}	DPG		50		ns
$\overline{\text{PBCTL}}$ input high and low level widths	t _{CTH} t _{CTL}	$\overline{\text{PBCTL}}$	t _{sys} = 2000/fc	t _{FRC} × 8 + t _{sys} + 200		ns
EXI input high and low level widths	t _{EIH} t _{EIL}	EXI0 EXI1	t _{sys} = 2000/fc	t _{FRC} × 8 + t _{sys} + 200		ns
PMI input high and low level widths	t _{PIH} t _{PIL}	PMI		t _{sys} + 200		ns
PMSK input high and low level widths	t _{PSH} t _{PSL}	PMSK		t _{sys} + 200		ns

Note 1) t_{sys} indicates three values according to the contents of the clock control register (address; 00FEH) upper 2 bits (CPU clock selection).

t_{sys} [ns] = 2000/fc (Upper 2 bits = "00"), 4000/fc (Upper 2 bits = "01"), 16000/fc (Upper 2 bits = "11")

Note 2) The value of t_{FRC} is as follows by selecting FRC clock (FRCS: 01EEH bit 7)

When PS0 is selected, t_{FRC} = 1000/fc [ns]

When PS1 is selected, t_{FRC} = 2000/fc [ns]

Fig. 12. Other timings

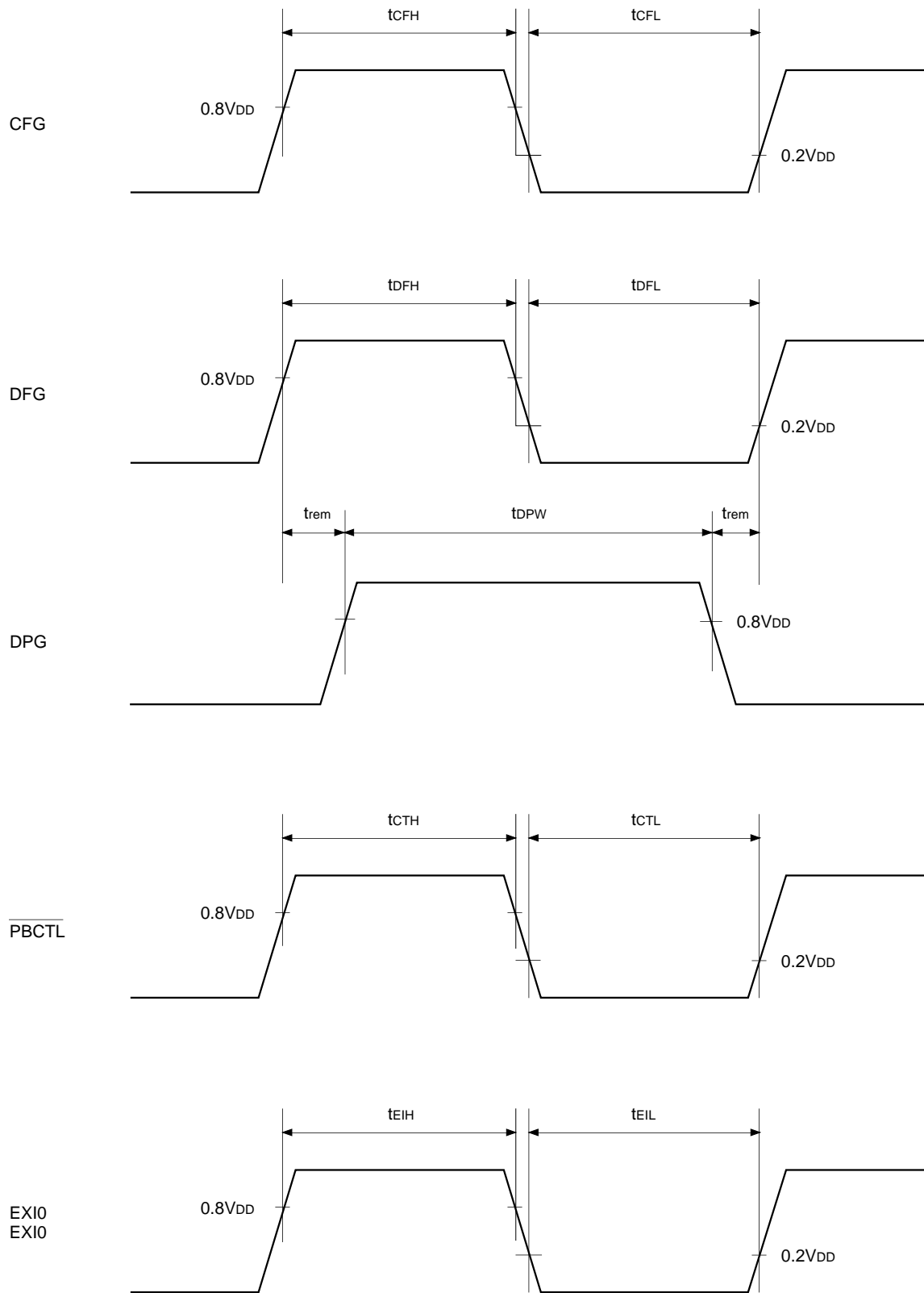

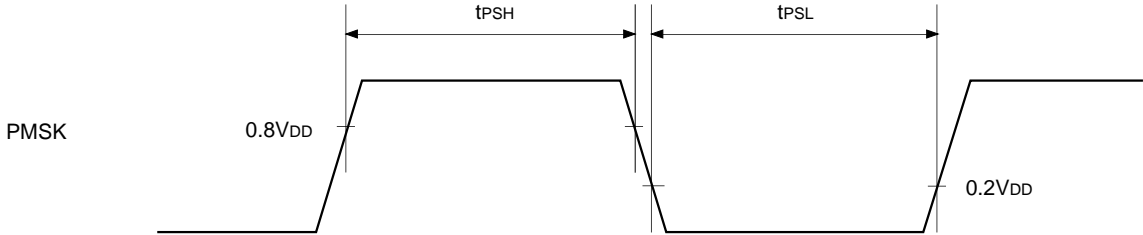
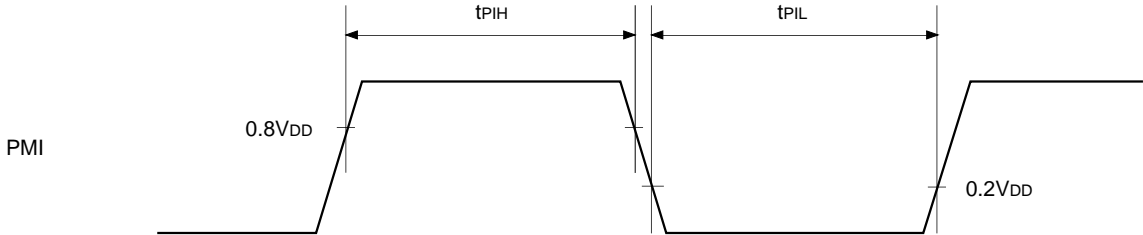

Supplement

Fig. 13. Recommended oscillation circuit

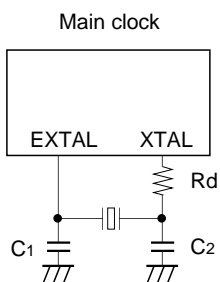

Manufacturer	Model	fc (MHz)	C1 (pF)	C2 (pF)	Rd (Ω)	Circuit example
RIVER ELETEC CO., LTD.	HC-49/U03	8.00	10	10	0	(i)
		10.00				
		12.00	5	5		
		16.00				
KINSEKI LTD.	HC-49/U (-S)	8.00	22 (15)	22 (15)	0	(i)
		10.00				
		12.00	15	15		
		16.00				

Mask Option Table

Item	Mask product	CXP874P60Q-1- <input type="checkbox"/> <input type="checkbox"/> <input type="checkbox"/>	CXP874P60Q-2- <input type="checkbox"/> <input type="checkbox"/> <input type="checkbox"/>
Reset pin pull-up resistor	Non-existent/existent	Existent	Existent
Power on reset circuit	Non-existent/existent	Existent	Existent
General purpose prescaler oscillation circuit	Non-existent/existent	Non-existent	Existent
Input circuit format*	CMOS schmitt /TTL schmitt	CMOS schmitt	TTL schmitt

* In PG4/SYNC0/PMI pin and PG5/SYNC1 pin.

Characteristics Curve

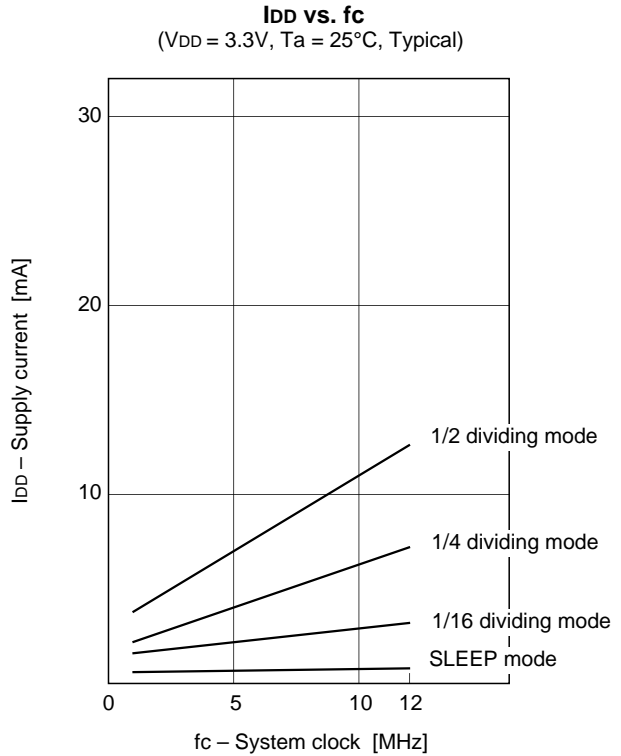
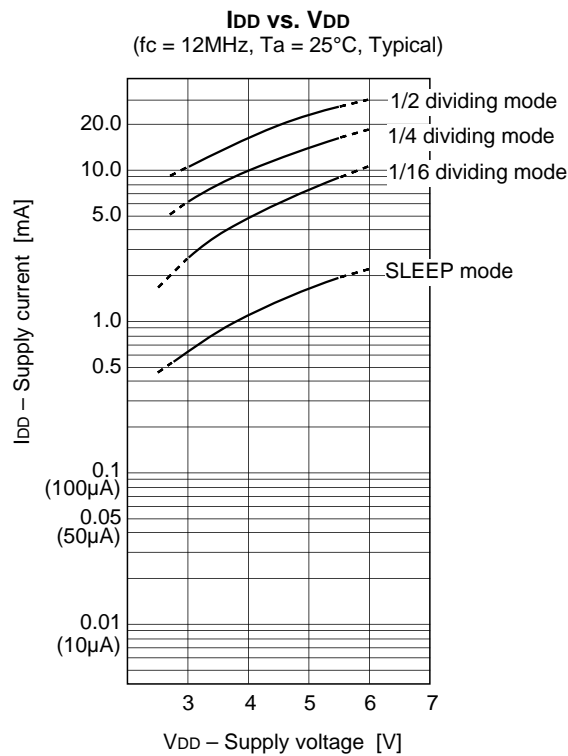
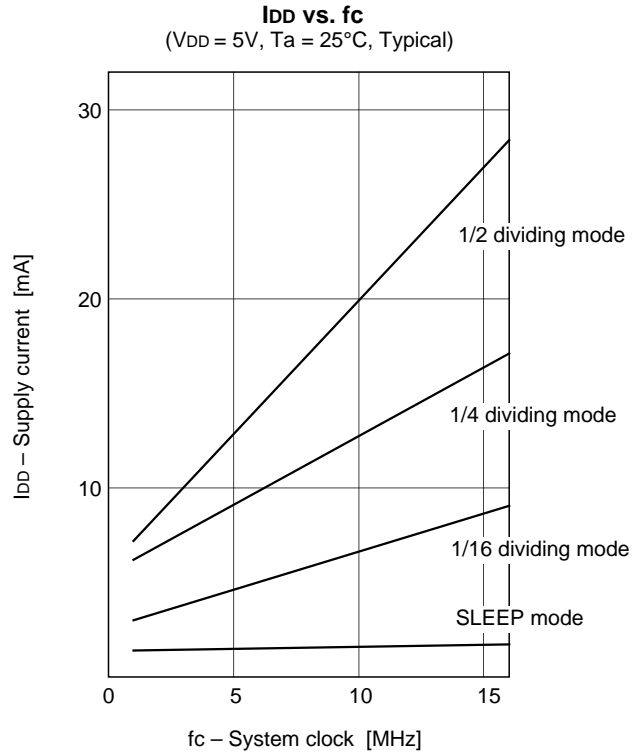
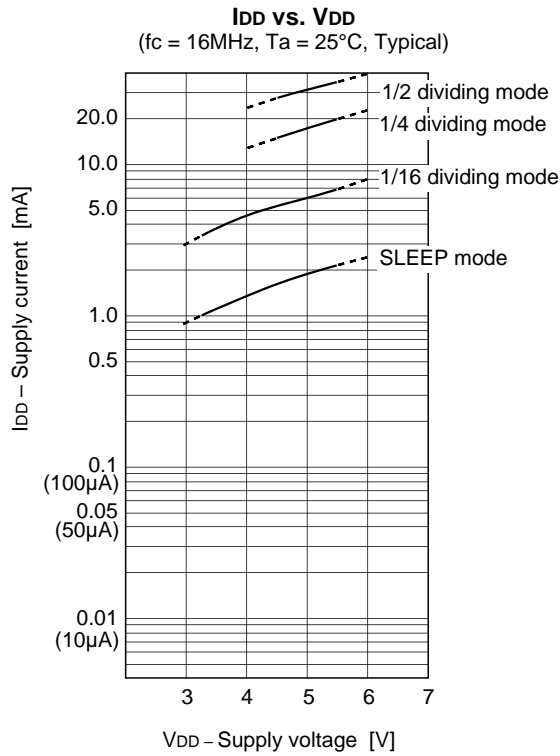

Package Outline

Unit: mm

100PIN QFP (PLASTIC)

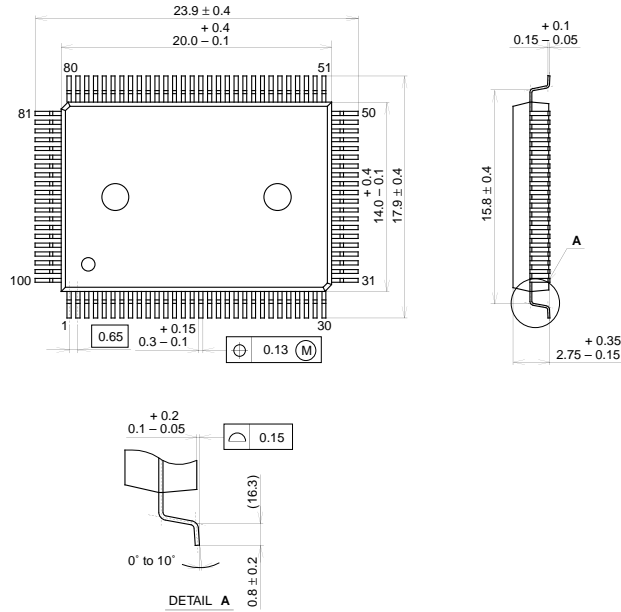

SONY CODE	QFP-100P-L01
EIAJ CODE	QFP100-P-1420
JEDEC CODE	

PACKAGE STRUCTURE	
PACKAGE MATERIAL	EPOXY RESIN
LEAD TREATMENT	SOLDER PLATING
LEAD MATERIAL	42/COPPER ALLOY
PACKAGE MASS	1.7g

100PIN QFP (PLASTIC)

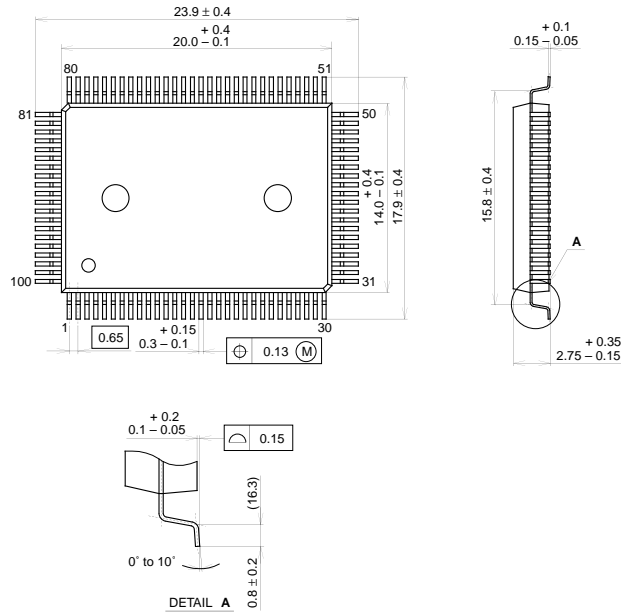

SONY CODE	QFP-100P-L01
EIAJ CODE	QFP100-P-1420
JEDEC CODE	

PACKAGE STRUCTURE	
PACKAGE MATERIAL	EPOXY RESIN
LEAD TREATMENT	SOLDER PLATING
LEAD MATERIAL	42/COPPER ALLOY
PACKAGE MASS	1.7g

LEAD PLATING SPECIFICATIONS

ITEM	SPEC.
LEAD MATERIAL	42 ALLOY
SOLDER COMPOSITION	Sn-Bi Bi:1-4wt%
PLATING THICKNESS	5-18μm



LittleDiode supplies new, hard to find or obsolete electronic components and semiconductors all over the world.

With over two million different components listed you are sure to find the part you need.

Feel free to visit us today at our online store:

LittleDiode.com

Looking forward to providing you with the best possible service.