

**CMOS 8-bit Single Chip Microcomputer****Description**

The CXP86609/86613/86617 are the CMOS 8-bit single chip microcomputer integrating on a single chip an A/D converter, serial interface, timer/counter, time-base timer, I<sup>2</sup>C bus interface, PWM output, remote control reception circuit, watchdog timer, 32kHz timer/counter besides the basic configurations of 8-bit CPU, ROM, RAM, I/O ports.

The CXP86609/86613/86617 also provide a sleep function that enables to lower the power consumption.

**Features**

- A wide instruction set (213 instructions) which covers various types of data
  - 16-bit operation/multiplication and division/Boolean bit operation instructions
- Minimum instruction cycle      250ns at 16MHz operation  
    122µs at 32kHz operation
- Incorporated ROM                    8K bytes (CXP86609)  
    12K bytes (CXP86613)  
    16K bytes (CXP86617)
- Incorporated RAM                    352 bytes
- Peripheral functions
  - A/D converter                        8 bits, 6 channels, successive approximation method  
    (Conversion time of 3.25µs at 16MHz)
  - Serial interface                      8-bit clock sync type, 1 channel
  - Timer                                    8-bit timer  
    8-bit timer/counter  
    19-bit time-base timer  
    32kHz timer/counter
  - I<sup>2</sup>C bus interface
  - PWM output                            8 bits, 4 channels
  - Remote control reception circuit   8-bit pulse measurement counter, 6-stage FIFO
  - Watchdog timer
- Interruption                            11 factors, 11 vectors, multi-interruption possible
- Standby mode                         Sleep
- Package                                 52-pin plastic SDIP
- Piggyback/evaluator                 CXP86490 64-pin ceramic PSDIP

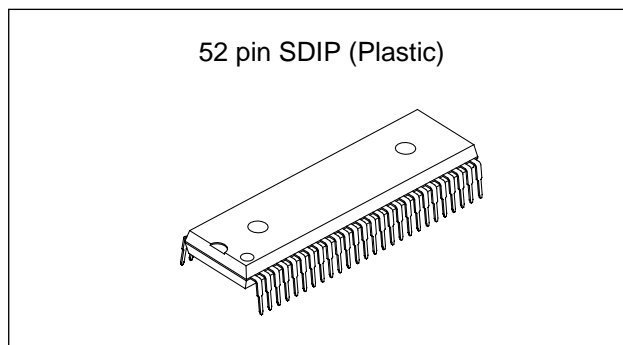
**Structure**

Silicon gate CMOS IC

Purchase of Sony's I<sup>2</sup>C components conveys a licence under the Philips I<sup>2</sup>C Patent Rights to use these components in an I<sup>2</sup>C system, provided that the system conforms to the I<sup>2</sup>C Standard Specifications as defined by Philips.

Sony reserves the right to change products and specifications without prior notice. This information does not convey any license by any implication or otherwise under any patents or other right. Application circuits shown, if any, are typical examples illustrating the operation of the devices. Sony cannot assume responsibility for any problems arising out of the use of these circuits.

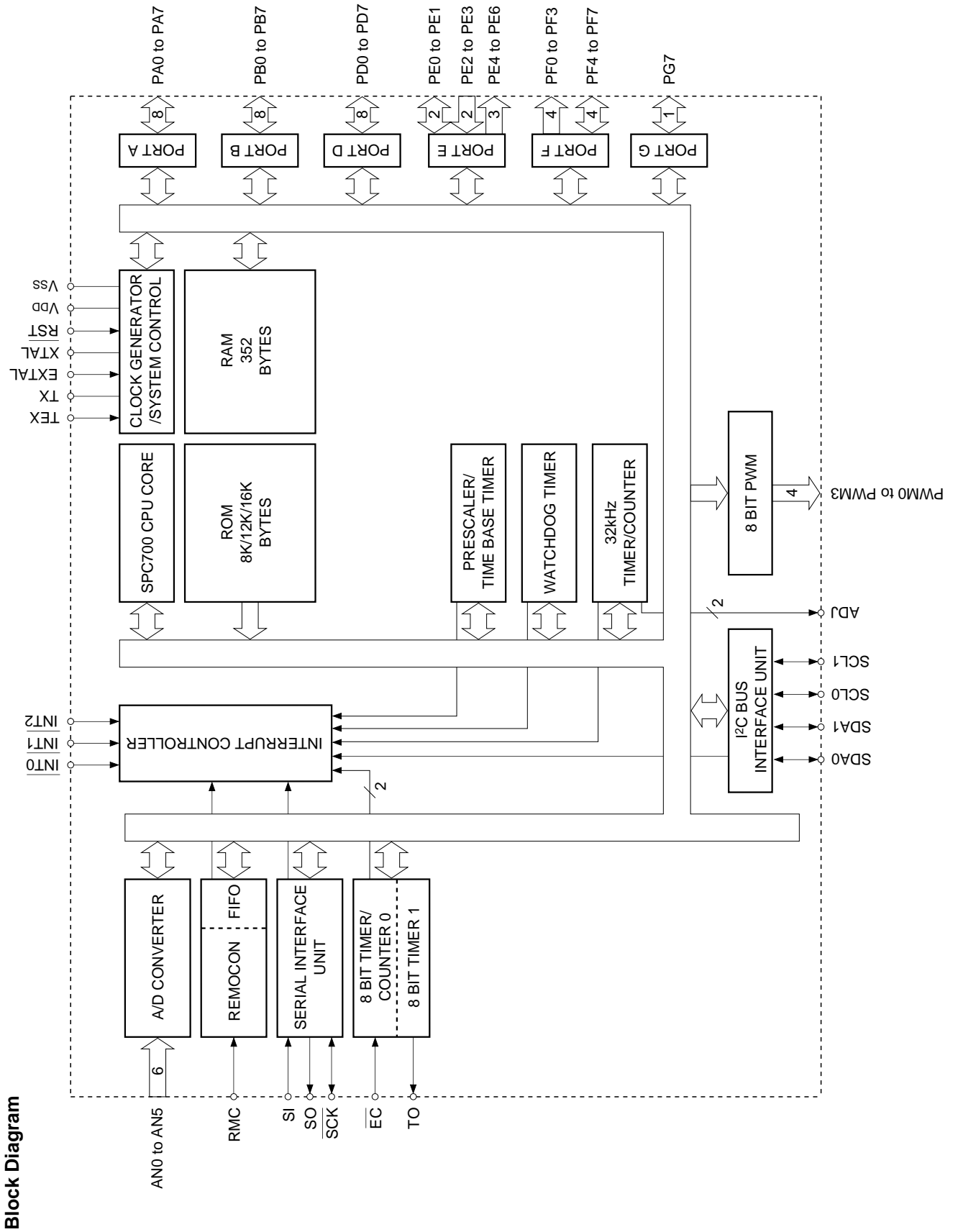

Pin Assignment (Top View)

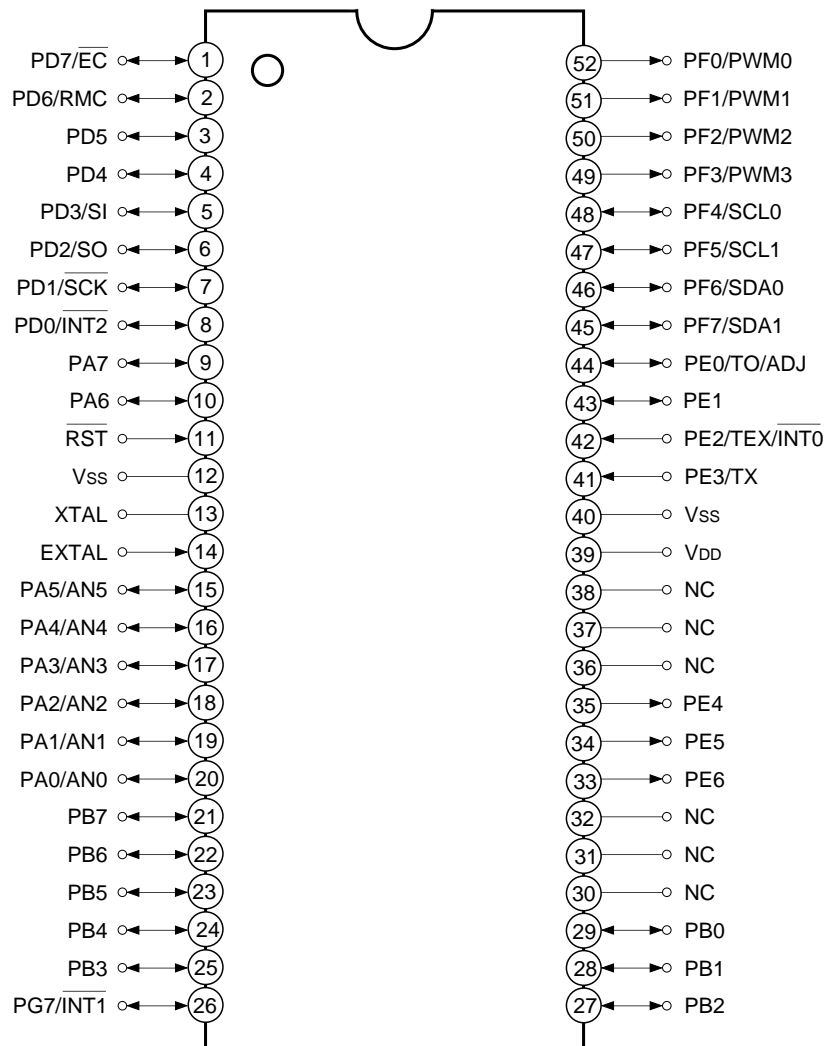

- Note)**
1. NC (Pins 30, 31, 32, 36 and 38) are left open.
  2. Vss (Pins 12 and 40) are both connected to GND.
  3. Pin 37 is the NC pin. However, connect it to VDD because it is the EXLC pin (input) for the piggyback/evaluator and OTP devices.

Pin Description

Symbol	I/O	Description		
PA0/AN0 to PA5/AN5	I/O/ Analog input	(Port A) 8-bit I/O port. I/O can be set in a unit of single bits. (8 pins)	Analog inputs to A/D converter. (6 pins)	
PA6 to PA7	I/O			
PB0 to PB7	I/O	(Port B) 8-bit I/O port. I/O can be set in a unit of single bits. (8 pins)		
PD0/ $\overline{\text{INT2}}$	I/O/Input	(Port D) 8-bit I/O port. I/O can be set in a unit of single bits. Can drive 12mA sink current. (8 pins)	External interruption request input. Active at the falling edge.	
PD1/ $\overline{\text{SCK}}$	I/O/I/O		Serial clock I/O.	
PD2/SO	I/O/Output		Serial data output.	
PD3/SI	I/O/Input		Serial data input.	
PD4 to PD5	I/O			
PD6/RMC	I/O/Input		Remote control reception circuit input.	
PD7/ $\overline{\text{EC}}$	I/O/Input		External event input for timer/counter.	
PE0/TO/ADJ	I/O/Output/ Output	(Port E) Bits 0 and 1 are I/O port; I/O can be set in a unit of single. Bits 2 and 3 are input port. Bits 4, 5 and 6 are output port. (7 pins)	Rectangular wave output for 8-bit timer/counter.	
PE1	I/O		32kHz oscillation frequency dividing output.	
PE2/TEX/ $\overline{\text{INT0}}$	Input/Input/ Input		Connects a crystal for 32kHz timer/counter clock oscillation. When used as an event counter, input to TEX pin and leave TX pin open.	External interruption request input. Active at the falling edge.
PE3/TX	Input/Output			
PE4 to PE6	Output			

Symbol	I/O	Description	
PF0/PWM0 to PF3/PWM3	Output/Output	(Port F) 8-bit output port and large current (12mA)	8-bit PWM output. (4 pins)
PF4/SCL0 to PF5/SCL1	Output/I/O	N-channel open drain output. Lower 4 bits are medium voltage drive (12V);	I <sup>2</sup> C bus interface transfer clock I/O. (2 pins)
PF6/SDA0 to PF7/SDA1	Output/I/O	upper 4 bits are 5V drive. (8 pins)	I <sup>2</sup> C bus interface transfer data I/O. (2 pins)
PG7/ $\overline{\text{INT1}}$	I/O/Input	(Port G) 1-bit I/O port. I/O can be set in a unit of single bits. (1 pin)	External interruption request input. Active at the falling edge.
EXTAL	Input	Connects a crystal for system clock oscillation. When a clock is supplied externally, input to EXTAL pin and input a reversed phase clock to XTAL pin.	
XTAL	Output		
$\overline{\text{RST}}$	Input	System reset; active at Low level.	
NC		No connected. Connect this pin to V <sub>DD</sub> under normal operation.	
V <sub>DD</sub>		Positive power supply.	
V <sub>SS</sub>		GND. Connect two V <sub>SS</sub> pins to GND.	

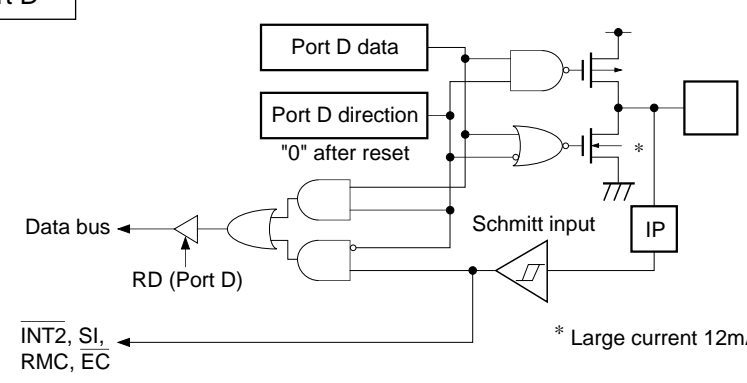
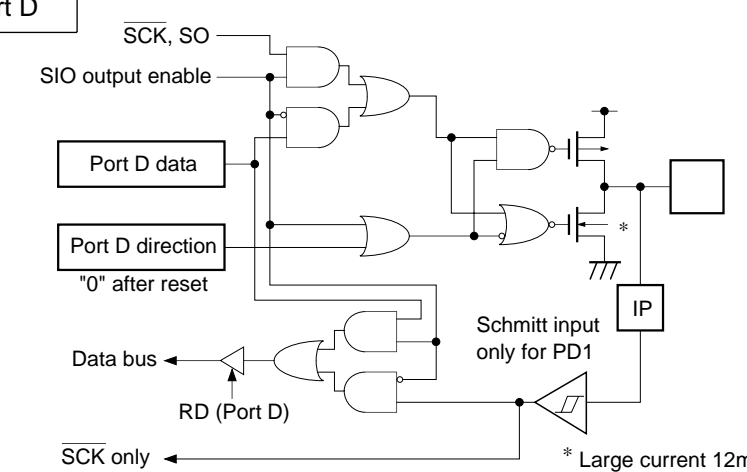
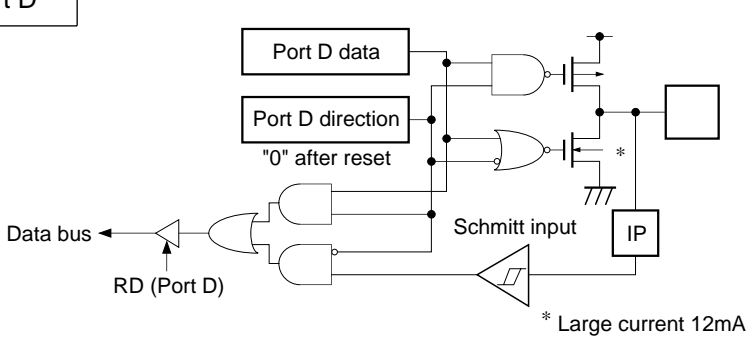

Pin	Circuit format	After reset
<p>PD0/<math>\overline{\text{INT2}}</math>                      PD3/SI                      PD6/RMC                      PD7/<math>\overline{\text{EC}}</math></p> <p>4 pins</p>	<p>Port D</p>  <p>* Large current 12mA</p>	<p>Hi-Z</p>
<p>PD1/<math>\overline{\text{SCK}}</math>                      PD2/SO</p> <p>2 pins</p>	<p>Port D</p>  <p>* Large current 12mA</p>	<p>Hi-Z</p>
<p>PD4                      PD5</p> <p>2 pins</p>	<p>Port D</p>  <p>* Large current 12mA</p>	<p>Hi-Z</p>

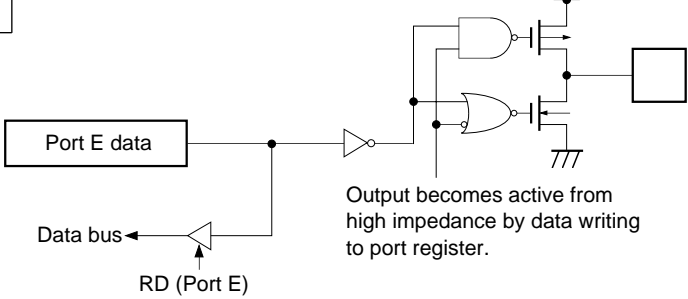
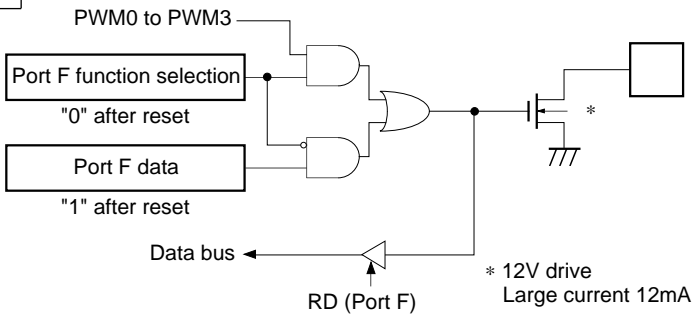
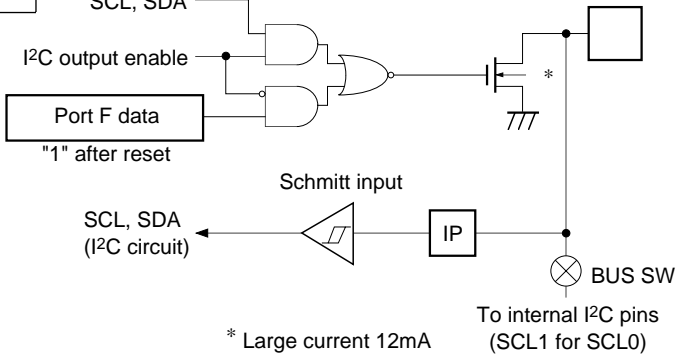
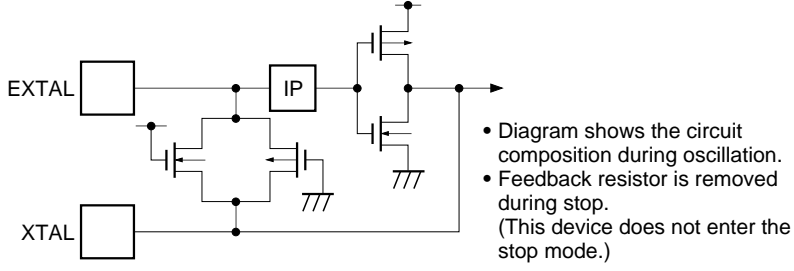
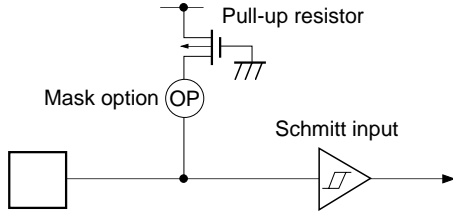

Pin	Circuit format	After reset
<p>PE4 PE5 PE6</p> <p>3 pins</p>	<p>Port E</p>  <p>Port E data</p> <p>Data bus</p> <p>RD (Port E)</p> <p>Output becomes active from high impedance by data writing to port register.</p>	<p>Hi-Z</p>
<p>PF0/PWM0 to PF3/PWM3</p> <p>4 pins</p>	<p>Port F</p>  <p>PWM0 to PWM3</p> <p>Port F function selection "0" after reset</p> <p>Port F data "1" after reset</p> <p>Data bus</p> <p>RD (Port F)</p> <p>* 12V drive Large current 12mA</p>	<p>Hi-Z</p>
<p>PF4/SCL0 PF5/SCL1 PF6/SDA0 PF7/SDA1</p> <p>4 pins</p>	<p>Port F</p>  <p>SCL, SDA</p> <p>I<sup>2</sup>C output enable</p> <p>Port F data "1" after reset</p> <p>Schmitt input</p> <p>SCL, SDA (I<sup>2</sup>C circuit)</p> <p>* Large current 12mA</p> <p>BUS SW</p> <p>To internal I<sup>2</sup>C pins (SCL1 for SCL0)</p>	<p>Hi-Z</p>
<p>EXTAL XTAL</p> <p>2 pins</p>	 <p>EXTAL</p> <p>XTAL</p> <p>IP</p> <ul style="list-style-type: none"> <li>• Diagram shows the circuit composition during oscillation.</li> <li>• Feedback resistor is removed during stop. (This device does not enter the stop mode.)</li> </ul>	<p>Oscillation</p>
<p><math>\overline{\text{RST}}</math></p> <p>1 pin</p>	 <p>Pull-up resistor</p> <p>Mask option OP</p> <p>Schmitt input</p>	<p>Low level (when reset)</p>

**Absolute Maximum Ratings**

(V<sub>SS</sub> = 0V reference)

Item	Symbol	Ratings	Unit	Remarks
Supply voltage	V <sub>DD</sub>	-0.3 to +7.0	V	
Input voltage	V <sub>IN</sub>	-0.3 to +7.0*1	V	
Output voltage	V <sub>OUT</sub>	-0.3 to +7.0*1	V	
Medium drive output voltage	V <sub>OUTP</sub>	-0.3 to +15.0	V	
High level output current	I <sub>OH</sub>	-5	mA	
High level total output current	ΣI <sub>OH</sub>	-50	mA	Total of all output pins
Low level output current	I <sub>OL</sub>	15	mA	Ports excluding large current output (value per pin)
	I <sub>OLC</sub>	20	mA	Large current output ports (value per pin*2)
Low level total output current	ΣI <sub>OL</sub>	130	mA	Total of all output pins
Operating temperature	T <sub>opr</sub>	-20 to +75	°C	
Storage temperature	T <sub>stg</sub>	-55 to +150	°C	
Allowable power dissipation	P <sub>D</sub>	375	mW	SDIP-52P-01

\*1 V<sub>IN</sub> and V<sub>OUT</sub> should not exceed V<sub>DD</sub> + 0.3V.

\*2 The large current output port is Port D (PD) and Port F (PF).

**Note)** Usage exceeding absolute maximum ratings may permanently impair the LSI. Normal operation should be conducted under the recommended operating conditions. Exceeding those conditions may adversely affect the reliability of the LSI.

**Recommended Operating Conditions**

(V<sub>SS</sub> = 0V reference)

Item	Symbol	Min.	Max.	Unit	Remarks
Supply voltage	V <sub>DD</sub>	4.5	5.5	V	Guaranteed operation range for 1/2 and 1/4 frequency dividing clocks
		3.5	5.5	V	Guaranteed operation range for 1/16 frequency dividing clock or sleep mode
		2.7	5.5	V	Guaranteed operation range for TEX
		—	—	V	Guaranteed data hold range for stop*1
High level input voltage	V <sub>IH</sub>	0.7V <sub>DD</sub>	V <sub>DD</sub>	V	*2
	V <sub>IHS</sub>	0.8V <sub>DD</sub>	V <sub>DD</sub>	V	*3
	V <sub>IHEX</sub>	V <sub>DD</sub> - 0.4	V <sub>DD</sub> + 0.3	V	EXTAL pin*4, TEX pin*5
Low level input voltage	V <sub>IL</sub>	0	0.3V <sub>DD</sub>	V	*2
	V <sub>ILS</sub>	0	0.2V <sub>DD</sub>	V	*3
	V <sub>ILEX</sub>	-0.3	0.4	V	EXTAL pin*4, TEX pin*5
Operating temperature	T <sub>opr</sub>	-20	+75	°C	

\*1 This device does not enter the stop mode.

\*2 PA0 to PA5, PB0 to PB7, PD2, PE0, PE1, PE3, SCL0, SCL1, SDA0, SDA1 pins

\*3 PA6, PA7, INT2, SCK, SI, PD4, PD5, RMC, EC, INT0, INT1, RST pins

\*4 Specifies only during external clock input.

\*5 Specifies only during external event count input.

Electrical Characteristics

DC characteristics

(Ta = -20 to +75°C, Vss = 0V reference)

Item	Symbol	Pins	Conditions	Min.	Typ.	Max.	Unit
High level output voltage	VOH	PA, PB, PD, PE0 to PE1, PE4 to PE6, PG7	VDD = 4.5V, IOH = -0.5mA	4.0			V
			VDD = 4.5V, IOH = -1.2mA	3.5			V
Low level output voltage	VOL	PA, PB, PD, PE0 to PE1, PE4 to PE6, PF0 to PF3, PG7	VDD = 4.5V, IOL = 1.8mA			0.4	V
			VDD = 4.5V, IOL = 3.6mA			0.6	V
		PD, PF	VDD = 4.5V, IOL = 12.0mA			1.5	V
		PF4 to PF7 (SCL0, SCL1, SDA0, SDA1)	VDD = 4.5V, IOL = 3.0mA			0.4	V
			VDD = 4.5V, IOL = 4.0mA			0.6	V
Input current	IiHE	EXTAL	VDD = 5.5V, VIH = 5.5V	0.5		40	μA
	IiLE			VDD = 5.5V, VIL = 0.4V	-0.5		-40
	IiHT	TEX	VDD = 5.5V, VIH = 5.5V	0.1		10	μA
	IiLT			VDD = 5.5V, VIL = 0.4V	-0.1		-10
	IiLR	RST*1	VDD = 5.5V, VIL = 0.4V	-1.5		-400	μA
I/O leakage current	IIZ	PA, PB, PD, PE, PG7, RST*1	VDD = 5.5V, VI = 0, 5.5V			±10	μA
Open drain I/O leakage current (in N-ch Tr off state)	ILOH	PF0 to PF3	VDD = 5.5V, VOH = 12.0V			50	μA
		PF4 to PF7	VDD = 5.5V, VOH = 5.5V			10	μA
I <sup>2</sup> C bus switch connection impedance (in output Tr off state)	RBS	SCL0: SCL1 SDA0: SDA1	VDD = 4.5V VSCL0 = VSCL1 = 2.25V VSDA0 = VSDA1 = 2.25V			120	Ω
Supply current*2	IDD1	VDD	1/2 frequency dividing clock operation		18	28	mA
			VDD = 5.5V, 16MHz crystal oscillation (C1 = C2 = 15pF)				
	IDD2		VDD = 3.3V, 32MHz crystal oscillation (C1 = C2 = 47pF)		30	80	μA
	IDDS1		Sleep mode		1.2	2.1	mA
			VDD = 5.5V, 16MHz crystal oscillation (C1 = C2 = 15pF)				
IDDS2	VDD = 3.3V, 32MHz crystal oscillation (C1 = C2 = 47pF)		12	35	μA		
IDDS3	Stop mode*3 VDD = 5.5V, termination of 16MHz and 32MHz oscillation		—	—	—	μA	

Item	Symbol	Pins	Conditions	Min.	Typ.	Max.	Unit
Input capacitance	C <sub>IN</sub>	PA, PB, PD, PE0 to PE3, PF4 to PF7, PG7, EXTAL, TEX, $\overline{\text{RST}}$	Clock 1MHz 0V for no measured pins		10	20	pF

\*1 For  $\overline{\text{RST}}$  pin, specifies the input current when pull-up resistor is selected, and specifies the leakage current when non-resistor is selected.

\*2 When all output pins are left open.

\*3 This device does not enter the stop mode.

AC Characteristics

(1) Clock timing

(Ta = -20 to +75°C, VDD = 4.5 to 5.5V, VSS = 0V reference)

Item	Symbol	Pins	Conditions	Min.	Typ.	Max.	Unit
System clock frequency	fc	XTAL EXTAL	Fig. 1, Fig. 2	8		16	MHz
System clock input pulse width	t <sub>XL</sub> , t <sub>XH</sub>	EXTAL	Fig. 1, Fig. 2 External clock drive	28			ns
System clock input rise and fall times	t <sub>CR</sub> , t <sub>CF</sub>	EXTAL	Fig. 1, Fig. 2 External clock drive			200	ns
Event count input clock pulse width	t <sub>EH</sub> , t <sub>EL</sub>	$\overline{EC}$	Fig. 3	4t <sub>sys</sub> *1			ns
Event count input clock rise and fall times	t <sub>ER</sub> , t <sub>EF</sub>	$\overline{EC}$	Fig. 3			20	ms
System clock frequency	fc	TEX TX	V <sub>DD</sub> = 2.7 to 5.5V Fig. 2 (32kHz clock applied conditions)		32.768		kHz
Event count input clock input pulse width	t <sub>TL</sub> , t <sub>TH</sub>	TEX	Fig. 3	10			μs
Event count input clock rise and fall times	t <sub>TR</sub> , t <sub>TF</sub>	TEX	Fig. 3			20	ms

\*1 Indicates three values according to the contents of the clock control register (CLC: 00 FEh) upper 2 bits (CPU clock selection).

t<sub>sys</sub> [ns] = 2000/fc (Upper 2 bits = "00"), 4000/fc (Upper 2 bits = "01"), 16000/fc (Upper 2 bits = "11")

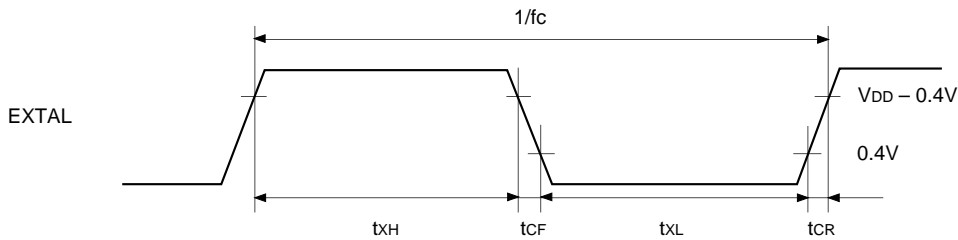

Fig. 1. Clock timing

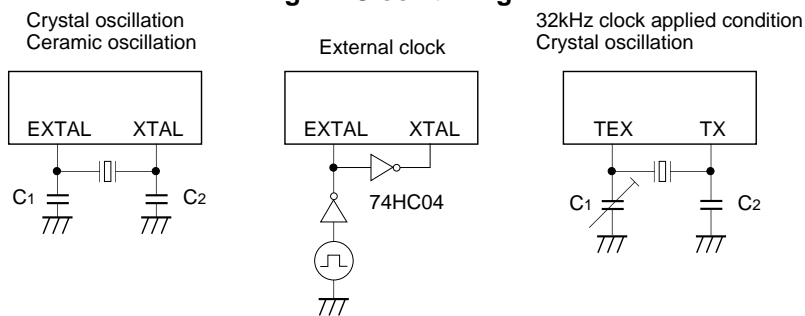

Fig.2. Clock applied conditions

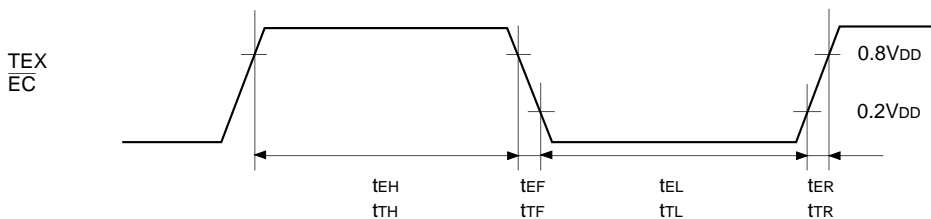

Fig. 3. Event count clock timing

(2) Serial transfer

( $T_a = -20$  to  $+75^\circ\text{C}$ ,  $V_{DD} = 4.5$  to  $5.5\text{V}$ ,  $V_{SS} = 0\text{V}$  reference)

Item	Symbol	Pins	Conditions	Min.	Max.	Unit
$\overline{\text{SCK}}$ cycle time	$t_{\text{KCY}}$	$\overline{\text{SCK}}$	Input mode	1000		ns
			Output mode	$8000/f_c$		ns
$\overline{\text{SCK}}$ High and Low level width	$t_{\text{KH}}$	$\overline{\text{SCK}}$	$\overline{\text{SCK}}$ input mode	400		ns
	$t_{\text{KL}}$		$\overline{\text{SCK}}$ output mode	$4000/f_c - 50$		ns
SI input setup time (for $\overline{\text{SCK}} \uparrow$ )	$t_{\text{SIK}}$	SI	$\overline{\text{SCK}}$ input mode	100		ns
			$\overline{\text{SCK}}$ output mode	200		ns
SI hold time (for $\overline{\text{SCK}} \uparrow$ )	$t_{\text{KSI}}$	SI	$\overline{\text{SCK}}$ input mode	200		ns
			$\overline{\text{SCK}}$ output mode	100		ns
$\overline{\text{SCK}} \downarrow \rightarrow \text{SO}$ delay time	$t_{\text{KSO}}$	SO	$\overline{\text{SCK}}$ input mode		200	ns
			$\overline{\text{SCK}}$ output mode		100	ns

**Note)** The load of  $\overline{\text{SCK}}$  output mode and SO output delay time is  $50\text{ pF} + 1\text{ TTL}$ .

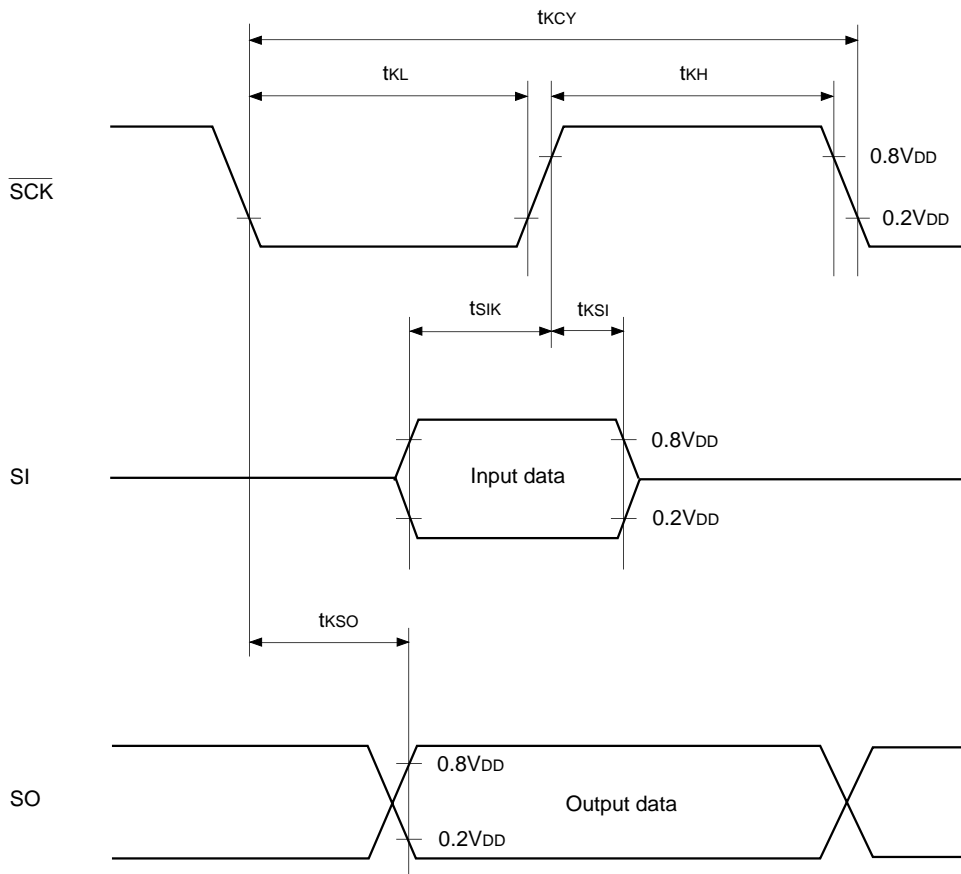
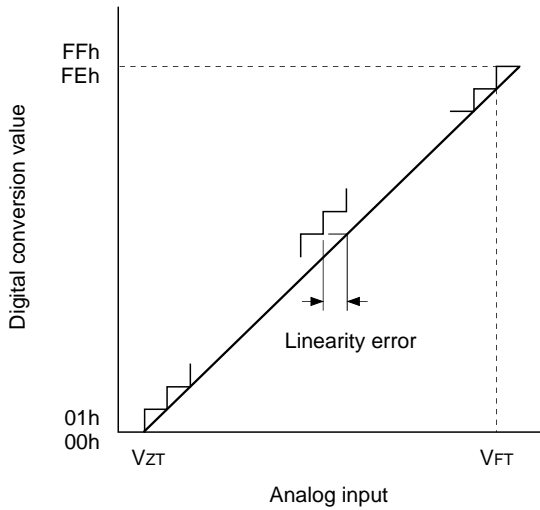

Fig. 4. Serial transfer timing

**(3) A/D converter characteristics**

( $T_a = -20$  to  $+75^\circ\text{C}$ ,  $V_{DD} = 4.5$  to  $5.5\text{V}$ ,  $V_{SS} = 0\text{V}$  reference)

Item	Symbol	Pins	Conditions	Min.	Typ.	Max.	Unit
Resolution						8	Bits
Linearity error			$T_a = 25^\circ\text{C}$ $V_{DD} = 5.0\text{V}$ $V_{SS} = 0\text{V}$			$\pm 3$	LSB
Zero transition voltage	$V_{ZT}^{*1}$			-10	10	70	mV
Full-scale transition voltage	$V_{FT}^{*2}$			4910	4970	5030	mV
Conversion time	$t_{CONV}$			$26/f_{ADC}^{*3}$			$\mu\text{s}$
Sampling time	$t_{SAMP}$			$6/f_{ADC}^{*3}$			$\mu\text{s}$
Analog input voltage	$V_{IAN}$	AN0 to AN5		0		$V_{DD}$	V



\*1  $V_{ZT}$ : Value at which the digital conversion value changes from 00h to 01h and vice versa.

\*2  $V_{FT}$ : Value at which the digital conversion value changes from FEh to FFh and vice versa.

\*3  $f_{ADC}$  indicates the below values due to the contents of bit 6 (CKS) of the A/D control register (ADC: 00F6h):

$$f_{ADC} = f_c \text{ (CKS = "0")}, f_c/2 \text{ (CKS = "1")}$$

**Fig. 5. Definitions of A/D converter terms**

**(4) Interruption, reset input** ( $T_a = -20$  to  $+75^\circ\text{C}$ ,  $V_{DD} = 4.5$  to  $5.5\text{V}$ ,  $V_{SS} = 0\text{V}$  reference)

Item	Symbol	Pins	Conditions	Min.	Max.	Unit
External interruption High, Low level width	$t_{IH}$ $t_{IL}$	$\overline{\text{INT0}}$ $\overline{\text{INT1}}$ $\overline{\text{INT2}}$		1		$\mu\text{s}$
Reset input Low level width	$t_{RSL}$	$\overline{\text{RST}}$		$32/f_c$		$\mu\text{s}$

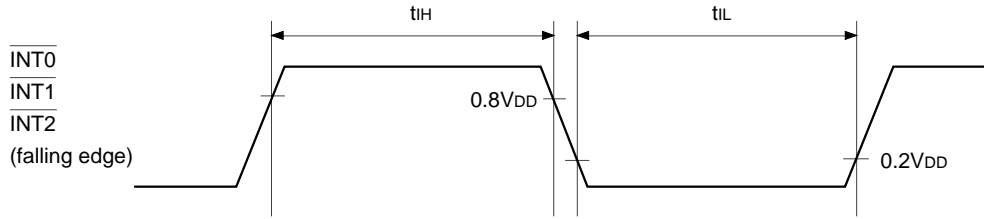

**Fig. 6. Interruption input timing**

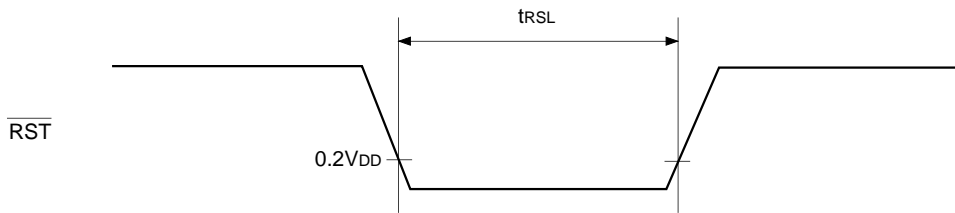

**Fig. 7.  $\overline{\text{RST}}$  input timing**

(5) I<sup>2</sup>C bus timing

(Ta = -20 to +75°C, V<sub>DD</sub> = 4.5 to 5.5V, V<sub>SS</sub> = 0V reference)

Item	Symbol	Pins	Conditions	Min.	Max.	Unit
SCL clock frequency	f <sub>SCL</sub>	SCL		0	100	kHz
Bus-free time before starting transfer	t <sub>BUF</sub>	SDA, SCL		4.7		μs
Hold time for starting transfer	t <sub>HD; STA</sub>	SDA, SCL		4.0		μs
Clock Low level width	t <sub>LOW</sub>	SCL		4.7		μs
Clock High level width	t <sub>HIGH</sub>	SCL		4.0		μs
Setup time for repeated transfers	t <sub>SU; STA</sub>	SDA, SCL		4.7		μs
Data hold time	t <sub>HD; DAT</sub>	SDA, SCL		0*1		μs
Data setup time	t <sub>SU; DAT</sub>	SDA, SCL		250		ns
SDA, SCL rise time	t <sub>R</sub>	SDA, SCL			1	μs
SDA, SCL fall time	t <sub>F</sub>	SDA, SCL			300	ns
Setup time for transfer completion	t <sub>SU; STO</sub>	SDA, SCL		4.7		μs

\*1 The data hold time should be 300ns or more because the SCL rise time (300ns Max.) is not included in it.

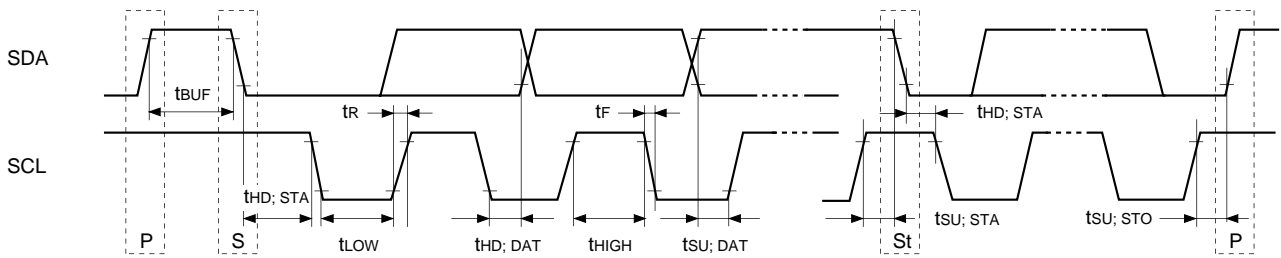

Fig. 8. I<sup>2</sup>C bus transfer timing

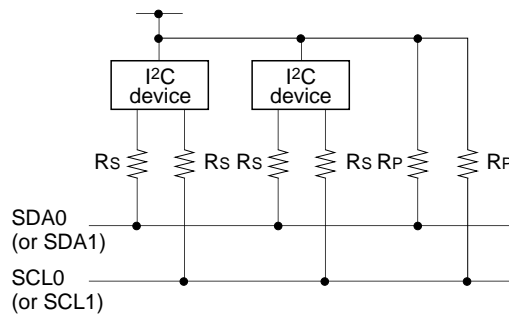

Fig. 9. I<sup>2</sup>C device recommended circuit

- A pull-up resistor (Rp) must be connected to SDA0 (or SDA1) and SCL0 (or SCL1).
- The SDA0 (or SDA1) and SCL0 (or SCL1) series resistance (Rs = 300Ω or less) can be used to reduce the spike noise caused by CRT flashover.

Appendix

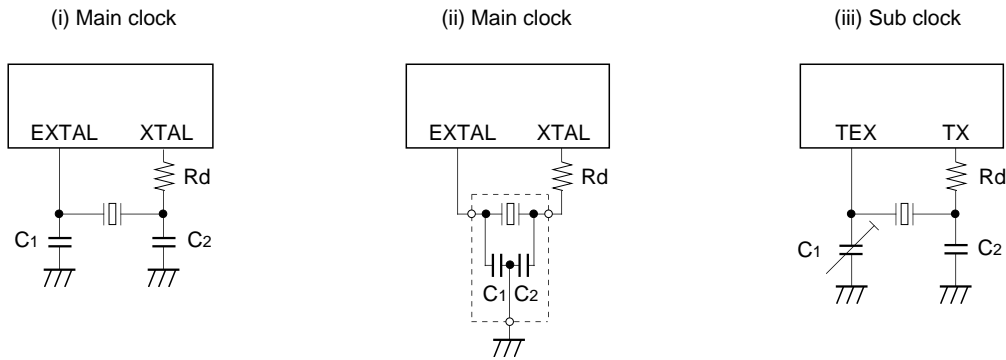

Fig. 10. Recommended oscillation circuit

Manufacture	Model	fc (MHz)	C1 (pF)	C2 (pF)	Rd ( $\Omega$ )	Circuit example
MURATA MFG CO., LTD.	CSA10.0MTZ	10.0	30	30	0* <sup>1</sup>	(i)
	CSA12.0MTZ	12.0				
	CSA16.00MXZ040	16.0	5	5		
	CST10.0MTW*	10.0	30	30		(ii)
	CST12.0MTW*	12.0				
	CST16.00MXW0C1*	16.0				
RIVER ELETEC CORPORATION	HC-49/U03	8.0	18	18	330* <sup>1</sup>	(i)
		12.0	12	12		
		16.0	10	10		
KINSEKI LTD.	HC-49/U (-S)	8.0	10	10	0* <sup>1</sup>	
		12.0	5	5		
		16.0	Open	Open		
	P3	32.768kHz	30	33	120k	(iii)

\*Models with an asterisk have the built-in ground capacitance (C1, C2).

\*<sup>1</sup> The series resistor for XTAL can reduce the effect of the noise caused by the electrostatic discharge.

Mask Option Table

Item	Content	
Reset pin pull-up resistor	Non-existent	Existent

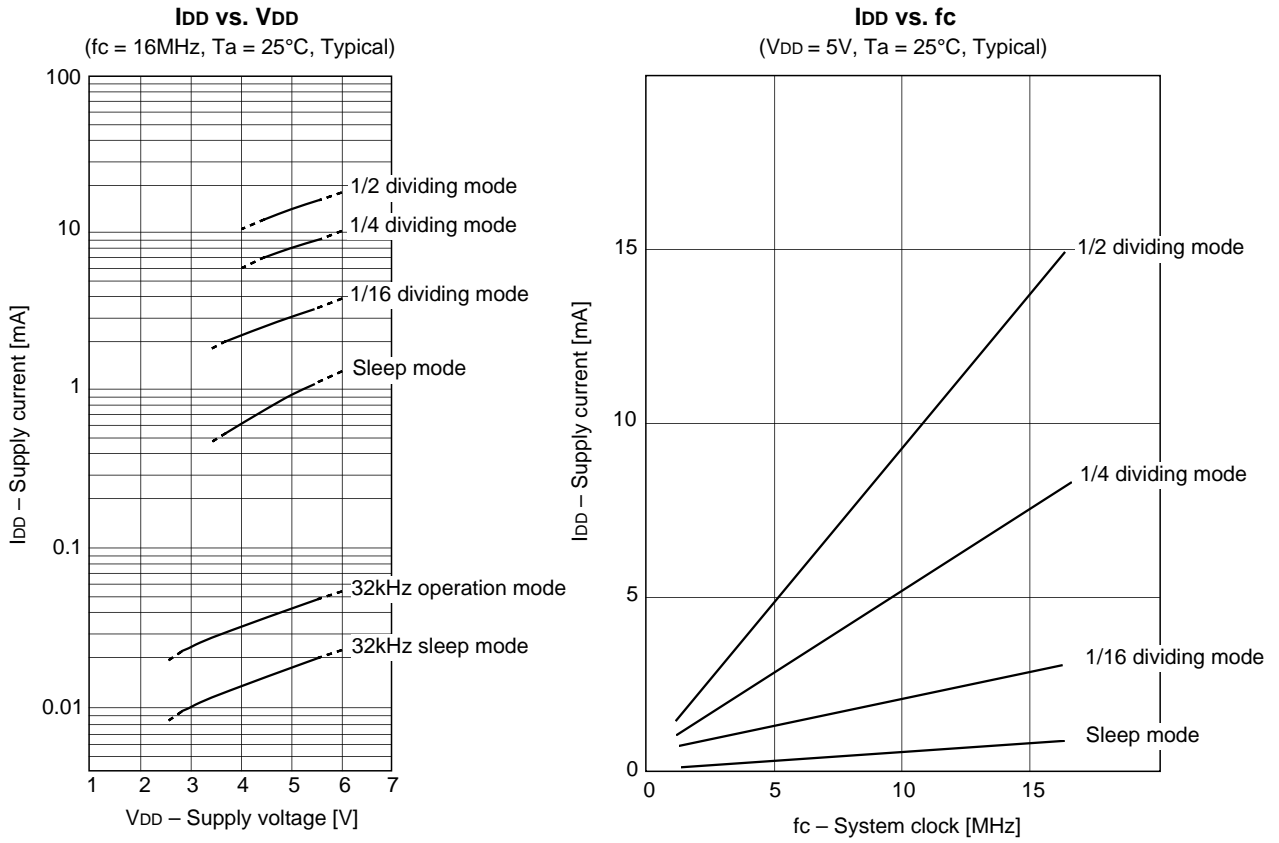
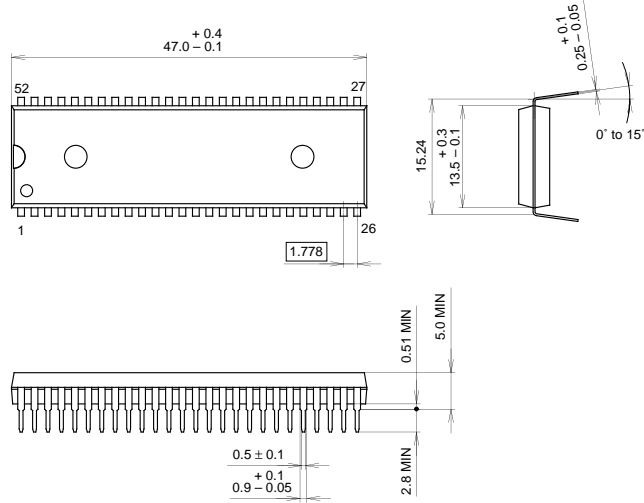

Fig. 11. Characteristic curves

Package Outline

Unit: mm

52PIN SDIP (PLASTIC)



PACKAGE STRUCTURE

SONY CODE	SDIP-52P-01
EIAJ CODE	P-SDIP52-13.5x47.0-1.778
JEDEC CODE	_____

PACKAGE MATERIAL	EPOXY RESIN
LEAD TREATMENT	SOLDER PLATING
LEAD MATERIAL	COPPER ALLOY
PACKAGE MASS	5.6g

52PIN SDIP (PLASTIC)

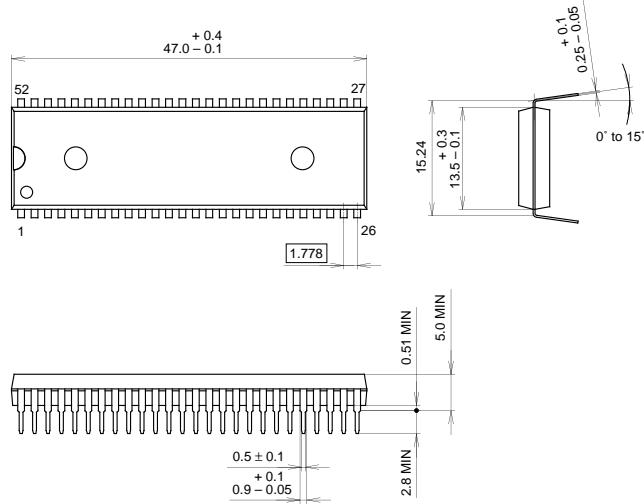

PACKAGE STRUCTURE

SONY CODE	SDIP-52P-01
EIAJ CODE	P-SDIP52-13.5x47.0-1.778
JEDEC CODE	_____

PACKAGE MATERIAL	EPOXY RESIN
LEAD TREATMENT	SOLDER PLATING
LEAD MATERIAL	COPPER ALLOY
PACKAGE MASS	5.6g

LEAD PLATING SPECIFICATIONS

ITEM	SPEC.
LEAD MATERIAL	COPPER ALLOY
SOLDER COMPOSITION	Sn-Bi Bi:1-4wt%
PLATING THICKNESS	5-18μm



LittleDiode supplies new, hard to find or obsolete electronic components and semiconductors all over the world.

With over two million different components listed you are sure to find the part you need.

Feel free to visit us today at our online store:

[LittleDiode.com](http://LittleDiode.com)

Looking forward to providing you with the best possible service.