

Pin Assignment (Top View)

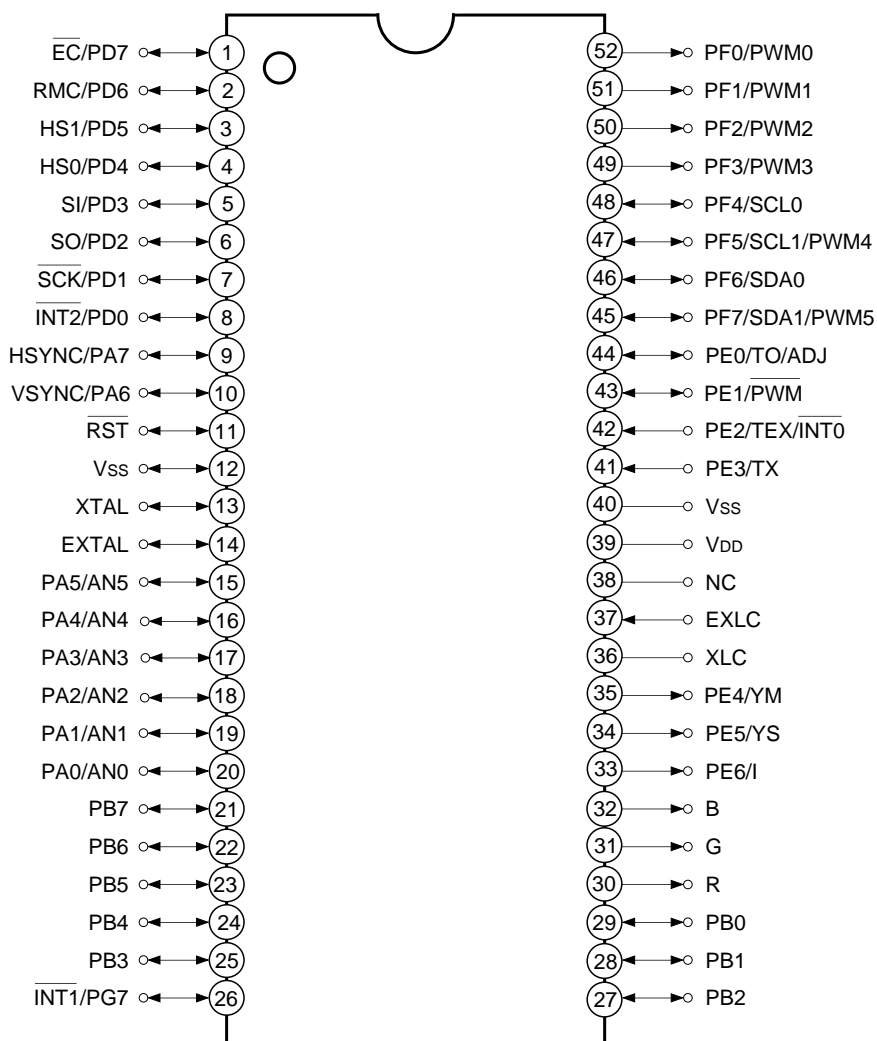

Note)

1. NC (Pin 38) is left open.
2. Vss (Pins 12 and 40) are both connected to GND.

Pin Description

Symbol	I/O	Description		
PA0/AN0 to PA5/AN5	I/O/ Analog input	(Port A) 8-bit I/O port. I/O can be set in a unit of single bits. (8 pins)	Analog inputs to A/D converter. (6 pins)	
PA6/VSYNC	I/O/Input		OSD display vertical sync signal input.	
PA7/HSYNC	I/O/Input		OSD display horizontal sync signal input.	
PB0 to PB7	I/O	(Port B) 8-bit I/O port. I/O can be set in a unit of single bits. (8 pins)		
PD0/ $\overline{\text{INT2}}$	I/O/Input	(Port D) 8-bit I/O port. I/O can be set in a unit of single bits. Can drive 12mA synk current. (8 pins)	External interruption request input. Active at the falling edge.	
PD1/ $\overline{\text{SCK}}$	I/O/I/O		Serial clock I/O.	
PD2/SO	I/O/Output		Serial data output.	
PD3/SI	I/O/Input		Serial data input.	
PD4/HS0	I/O/Input		HSYNC counter (CH0) input.	
PD5/HS1	I/O/Input		HSYNC counter (CH1) input.	
PD6/RMC	I/O/Input		Remote control reception circuit input.	
PD7/ $\overline{\text{EC}}$	I/O/Input		External event input for timer/counter.	
PE0/TO/ADJ	I/O/Output/ Output	(Port E) Bits 0 and 1 are I/O port; I/O can be set in a unit of single. Bits 2 and 3 are input port. Bits 4, 5 and 6 are output port. (7 pins)	Rectangular wave output for 8-bit timer/counter.	
PE1/ $\overline{\text{PWM}}$	I/O/Output		32kHz oscillation frequency dividing output.	
PE2/ $\overline{\text{TEX/INT0}}$	Input/Input/ Input		14-bit PWM output.	
PE3/TX	Input/Output		Connects a crystal for 32kHz timer/counter clock oscillation. When used as an event counter, input to TEX pin and leave TX pin open.	External interruption request input. Active at the falling edge.
PE4/YM	Output/Output		OSD display 6-bit output. (6 pins)	
PE5/YS	Output/Output			
PE6/I	Output/Output			
B	Output			
G	Output			
R	Output			

Symbol	I/O	Description		
PF0/PWM0 to PF3/PWM3	Output/Output	(Port F) 8-bit output port.	8-bit PWM output. (4 pins)	
PF4/SCL0	Output/I/O	Open drain output of large current (12mA) and N channel. Lower 4 bits are medium drive voltage (12V); upper 4 bits are 5V drive. (8 pins)	I ² C bus interface transfer clock I/O. (2 pins)	
PF5/SCL1/ PWM4	Output/I/O/ Output			8-bit PWM output.
PF6/SDA0	Output/I/O		I ² C bus interface transfer data I/O. (2 pins)	8-bit PWM output.
PF7/SDA1/ PWM5	Output/I/O/ Output			
PG7/ $\overline{\text{INT1}}$	I/O/Input	(Port G) 1-bit I/O port.	External interruption request input. Active at the falling edge.	
EXTAL	Input	Connects a crystal for system clock oscillation. When a clock is supplied externally, input to EXTAL pin and input a reversed phase clock to XTAL pin.		
XTAL	Output			
$\overline{\text{RST}}$	Input	System reset; active at Low level.		
EXLC	Input	OSD display clock oscillation I/O. Oscillation frequency is determined by the external L and C.		
XLC	Output			
NC		No connected.		
V _{DD}		Positive power supply.		
V _{SS}		GND. Connect two V _{SS} pins to GND.		

Input/Output Circuit Formats for Pins

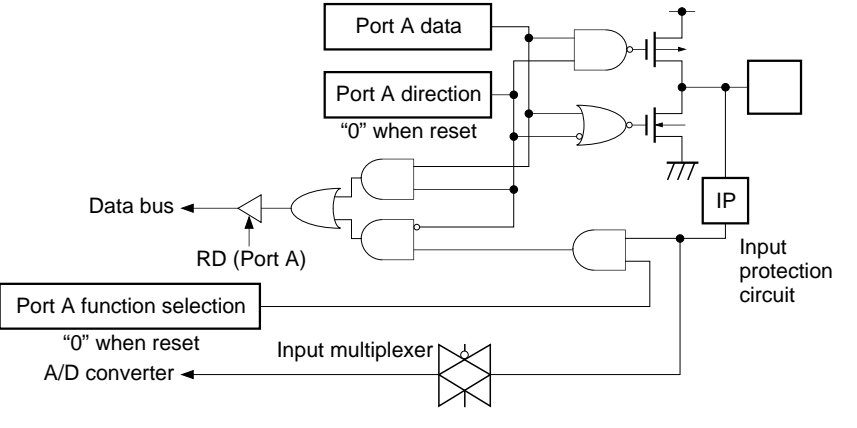
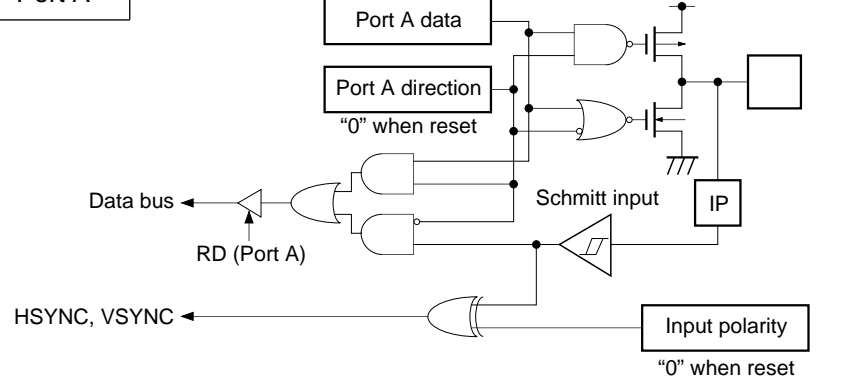
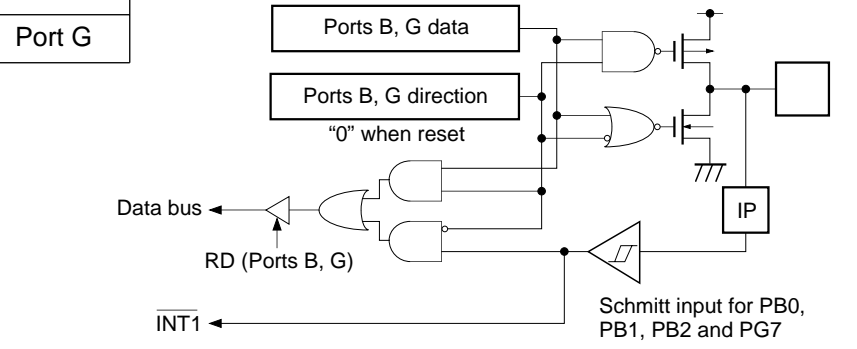
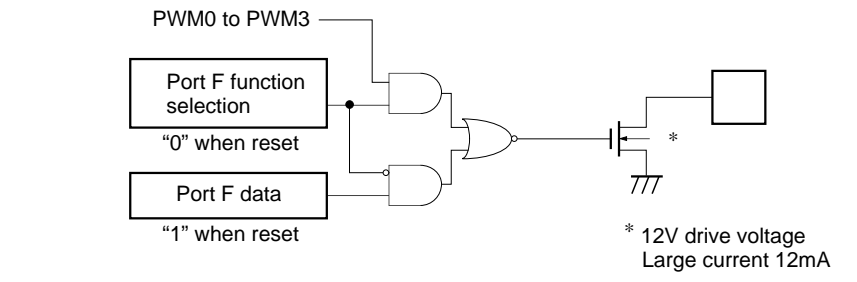
Pin	Circuit format	When reset
<p>PA0/AN0 to PA5/AN5</p> <p>6 pins</p>	<p>Port A</p> 	<p>Hi-Z</p>
<p>PA6/VSYNC PA7/HSYNC</p> <p>2 pins</p>	<p>Port A</p> 	<p>Hi-Z</p>
<p>PB0 to PB7 PG7/INT1</p> <p>9 pins</p>	<p>Port B</p> <p>Port G</p> 	<p>Hi-Z</p>
<p>PF0/PWM0 to PF3/PWM3</p> <p>4 pins</p>	<p>Port F</p>  <p>* 12V drive voltage Large current 12mA</p>	<p>Hi-Z</p>

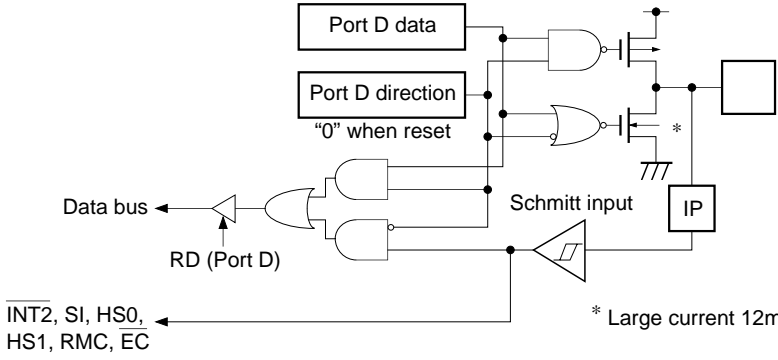
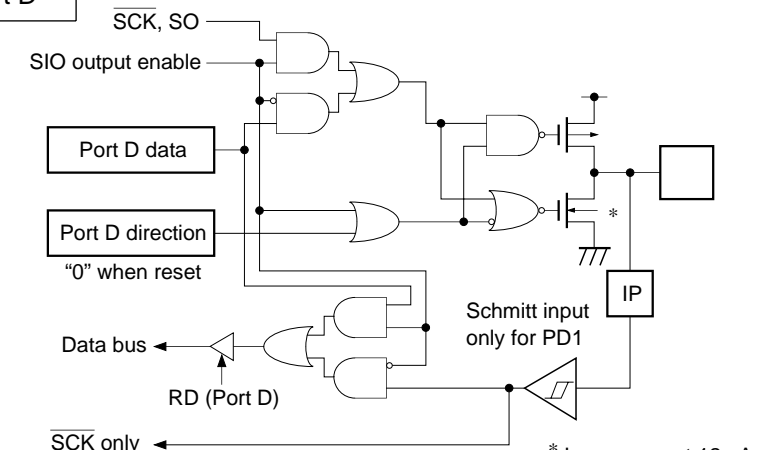
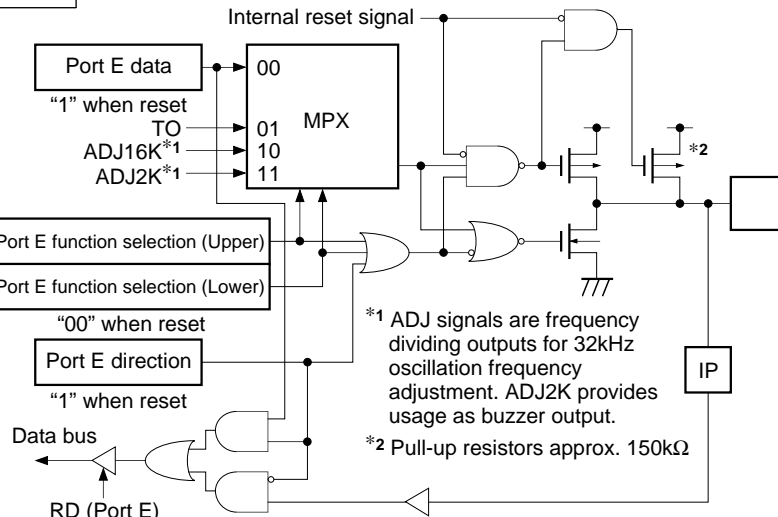
Pin	Circuit format	When reset
<p>PD0/$\overline{\text{INT2}}$ PD3/$\overline{\text{SI}}$ PD4/$\overline{\text{HS0}}$ PD5/$\overline{\text{HS1}}$ PD6/$\overline{\text{RMC}}$ PD7/$\overline{\text{EC}}$</p> <p>6 pins</p>	<p>Port D</p>  <p>* Large current 12mA</p>	<p>Hi-Z</p>
<p>PD1/$\overline{\text{SCK}}$ PD2/$\overline{\text{SO}}$</p> <p>2 pins</p>	<p>Port D</p>  <p>* Large current 12mA</p>	<p>Hi-Z</p>
<p>PE0/$\overline{\text{TO}}$/$\overline{\text{ADJ}}$</p> <p>1 pin</p>	<p>Port E</p>  <p>*1 ADJ signals are frequency dividing outputs for 32kHz oscillation frequency adjustment. ADJ2K provides usage as buzzer output. *2 Pull-up resistors approx. 150kΩ</p>	<p>High level (with the resistor of pull-up transistor ON when reset)</p>

Pin	Circuit format	When reset
<p>PE1/PWM</p> <p>1 pin</p>	<p>Port E</p> <p>PWM</p> <p>Port E function selection "0" when reset</p> <p>Port E data "1" when reset</p> <p>Port E direction "1" when reset</p> <p>Data bus</p> <p>RD (Port E)</p> <p>IP</p>	<p>High level</p>
<p>PE2/TEX/INT0 PE3/TX</p> <p>2 pins</p>	<p>Port E</p> <p>32kHz oscillation circuit control "1" when reset Schmitt input</p> <p>INT0</p> <p>Data bus</p> <p>RD (Port E)</p> <p>Data bus</p> <p>RD (Port E)</p> <p>Schmitt input</p> <p>Clock input</p> <p>PE2/ TEX/ INT0</p> <p>IP</p> <p>PE3/ TX</p> <p>IP</p>	<p>Oscillation halted Port input</p>
<p>PE4/YM PE5/YS PE6/I</p> <p>3 pins</p>	<p>Port E</p> <p>YM, YS, I</p> <p>Output polarity "0" when reset</p> <p>Port E function selection "0" when reset</p> <p>Port E data</p> <p>Data bus</p> <p>RD (Port E)</p> <p>IP</p> <p>Writing data to output polarity register and port data register brings output to active.</p>	<p>Hi-Z</p>

Pin	Circuit format	When reset
<p>PF4/SCL0 PF5/SCL1/PWM4 PF6/SDA0 PF7/SDA1/PWM5</p> <p>4 pins</p>	<p>Port F</p> <p>SCL, SDA</p> <p>I²C bus enable</p> <p>PWM4, PWM5</p> <p>Port F function selection "0" when reset</p> <p>Port F data "1" when reset</p> <p>Schmitt input</p> <p>SCL, SDA (I²C bus circuit)</p> <p>* Large current 12mA</p> <p>To internal I²C pins (SCL1 for SCL0)</p>	<p>Hi-Z</p>
<p>R G B</p> <p>3 pins</p>	<p>R, G, B</p> <p>Output polarity "0" when reset</p> <p>Writing data to output polarity register brings output to active.</p>	<p>Hi-Z</p>
<p>EXLC XLC</p> <p>2 pins</p>	<p>Oscillation control</p> <p>EXLC</p> <p>XLC</p> <p>OSD display clock</p>	<p>Oscillation halted</p>
<p>EXTAL XTAL</p> <p>2 pins</p>	<p>EXTAL</p> <p>XTAL</p> <ul style="list-style-type: none"> • Diagram shows the circuit composition during oscillation. • Feedback resistor is removed during stop mode. (This device does not enter the stop mode.) 	<p>Oscillation</p>
<p>$\overline{\text{RST}}$</p> <p>1 pin</p>	<p>Pull-up resistor</p> <p>Mask option</p> <p>Schmitt input</p>	<p>Low level</p>

Absolute Maximum Ratings

(V_{SS} = 0V reference)

Item	Symbol	Ratings	Unit	Remarks
Supply voltage	V _{DD}	-0.3 to +7.0	V	
Input voltage	V _{IN}	-0.3 to +7.0*1	V	
Output voltage	V _{OUT}	-0.3 to +7.0*1	V	
Medium drive output voltage	V _{OUTP}	-0.3 to +15.0	V	
High level output current	I _{OH}	-5	mA	
High level total output current	∑I _{OH}	-50	mA	Total of all output pins
Low level output current	I _{OL}	15	mA	Ports excluding large current output (value per pin)
	I _{OLC}	20	mA	Large current output ports (value per pin*2)
Low level total output current	∑I _{OL}	130	mA	Total of all output pins
Operating temperature	T _{opr}	-20 to +75	°C	
Storage temperature	T _{stg}	-55 to +150	°C	
Allowable power dissipation	P _D	375	mW	52-pin SDIP

*1 V_{IN} and V_{OUT} should not exceed V_{DD} + 0.3V.

*2 The large current output port is Port D (PD) and Port F (PF).

Note) Usage exceeding absolute maximum ratings may permanently impair the LSI. Normal operation should be conducted under the recommended operating conditions. Exceeding those conditions may adversely affect the reliability of the LSI.

Recommended Operating Conditions

(V_{SS} = 0V reference)

Item	Symbol	Min.	Max.	Unit	Remarks
Supply voltage	V _{DD}	4.5	5.5	V	Guaranteed operation range for 1/2 and 1/4 frequency dividing modes
		3.5	5.5	V	Guaranteed operation range for 1/16 frequency dividing mode or sleep mode
		2.7	5.5	V	Guaranteed operation range for TEX mode
		—	—	V	Guaranteed data hold range for stop mode*5
High level input voltage	V _{IH}	0.7V _{DD}	V _{DD}	V	*1
	V _{IHS}	0.8V _{DD}	V _{DD}	V	*2
	V _{IHEX}	V _{DD} - 0.4	V _{DD} + 0.3	V	EXTAL pin*3, TEX pin*4
Low level input voltage	V _{IL}	0	0.3V _{DD}	V	*1
	V _{ILS}	0	0.2V _{DD}	V	*2
	V _{ILEX}	-0.3	0.4	V	EXTAL pin*3, TEX pin*4
Operating temperature	T _{opr}	-20	+75	°C	

*1 PA1 to 5, PB3 to 7, PD2, PE0, PE1, PE3, SCL0 to 1, SDA0 to 1 pins

*2 VSYNC, HSYNC, INT2, SCK, SI, HS0, HS1, RMC, EC, INT0, INT1, RST, PB0, PB1, PB2 pins

*3 Specifies only during external clock input.

*4 Specifies only during external event count input.

*5 This device does not enter the stop mode.

Electrical Characteristics

DC characteristics

(Ta = -20 to +75°C, Vss = 0V reference)

Item	Symbol	Pins	Conditions	Min.	Typ.	Max.	Unit
High level output voltage	V _{OH}	PA, PB, PD, PE0 to PE1, PE4 to PE6, PG7, R, G, B	V _{DD} = 4.5V, I _{OH} = -0.5mA	4.0			V
			V _{DD} = 4.5V, I _{OH} = -1.2mA	3.5			V
Low level output voltage	V _{OL}	PA, PB, PD, PE0 to PE1, PE4 to PE6, PF0 to PF3, PG7, R, G, B	V _{DD} = 4.5V, I _{OL} = 1.8mA			0.4	V
			V _{DD} = 4.5V, I _{OL} = 3.6mA			0.6	V
		PD, PF	V _{DD} = 4.5V, I _{OL} = 12.0mA			1.5	V
		PF4 to PF7 (SCL0, SCL1, SDA0, SDA1)	V _{DD} = 4.5V, I _{OL} = 3.0mA			0.4	V
			V _{DD} = 4.5V, I _{OL} = 4.0mA			0.6	V
Input current	I _{IHE}	EXTAL	V _{DD} = 5.5V, V _{IH} = 5.5V	0.5		40	μA
	I _{ILE}			V _{DD} = 5.5V, V _{IL} = 0.4V	-0.5		-40
	I _{IHT}	TEX	V _{DD} = 5.5V, V _{IH} = 5.5V	0.1		10	μA
	I _{ILT}			V _{DD} = 5.5V, V _{IL} = 0.4V	-0.1		-10
	I _{ILR}	RST*1	V _{DD} = 5.5V, V _{IL} = 0.4V	-1.5		-400	μA
I/O leakage current	I _{Iz}	PA, PB, PD, PE, R, G, B, RST*1	V _{DD} = 5.5V, V _I = 0, 5.5V			±10	μA
Open drain I/O leakage current (in N-ch Tr off state)	I _{ILOH}	PF0 to PF3	V _{DD} = 5.5V, V _{OH} = 12.0V			50	μA
		PF4 to PF7	V _{DD} = 5.5V, V _{OH} = 5.5V			10	μA
I ² C bus switch connection impedance (in output Tr off state)	R _{Bs}	SCL0: SCL1 SDA0: SDA1	V _{DD} = 4.5V V _{SCL0} = V _{SCL1} = 2.25V V _{SDA0} = V _{SDA1} = 2.25V			120	Ω
Supply current*2	I _{DD1}	V _{DD}	1/2 frequency dividing mode V _{DD} = 5.5V, 16MHz crystal oscillation (C ₁ = C ₂ = 15pF)		18	28	mA
	I _{DD2}		V _{DD} = 3.3V, 32MHz crystal oscillation (C ₁ = C ₂ = 47pF)		30	80	μA
	I _{DDS1}		SLEEP mode V _{DD} = 5.5V, 16MHz crystal oscillation (C ₁ = C ₂ = 15pF)		1.2	2.1	mA
	I _{DDS2}		V _{DD} = 3.3V, 32MHz crystal oscillation (C ₁ = C ₂ = 47pF)		12	35	μA
	I _{DDS3}		STOP mode*3 V _{DD} = 5.5V, termination of 16MHz and 32MHz oscillation		—	—	—

Item	Symbol	Pins	Conditions	Min.	Typ.	Max.	Unit
Input capacitance	C _{IN}	PA, PB, PD, PE0 to PE3, R, G, B, PF4 to PF7, EXTAL, TEX, EXLC, RST	Clock 1MHz 0V other than the measured pins		10	20	pF

*1 For $\overline{\text{RST}}$ pin, specifies the input current when pull-up resistance is selected, and specifies the leakage current when non-resistor is selected.

*2 When all output pins are left open. Specifies only when the OSD oscillation is halted.

*3 This device does not enter the stop mode.

AC Characteristics

(1) Clock timing

(Ta = -20 to +75°C, VDD = 4.5 to 5.5V, VSS = 0V reference)

Item	Symbol	Pins	Conditions	Min.	Typ.	Max	Unit
System clock frequency	fc	XTAL EXTAL	Fig. 1, Fig. 2	8		16	MHz
System clock input pulse width	t _{XL} , t _{XH}	EXTAL	Fig. 1, Fig. 2 External clock drive	28			ns
System clock input rise and fall times	t _{CR} , t _{CF}	EXTAL	Fig. 1, Fig. 2 External clock drive			200	ns
Event count input clock pulse width	t _{EH} , t _{EL}	\overline{EC}	Fig. 3	4t _{sys} *1			ns
Event count input clock rise and fall times	t _{ER} , t _{EF}	\overline{EC}	Fig. 3			20	ms
System clock frequency	fc	TEX TX	VDD = 2.7 to 5.5V Fig. 2 (32kHz clock applied conditions)		32.768		kHz
Event count input clock pulse width	t _{TL} , t _{TH}	TEX	Fig. 3	10			μs
Event count input clock rise and fall times	t _{TR} , t _{TF}	TEX	Fig. 3			20	ms

*1 t_{sys} indicates three values according to the contents of the clock control register (CLC: 00FEh) upper 2 bits (CPU clock selection).

t_{sys} (ns) = 2000/fc (Upper 2 bits = "00"), 4000/fc (Upper 2 bits = "01"), 16000/fc (Upper 2 bits = "11")

Fig. 1. Clock timing

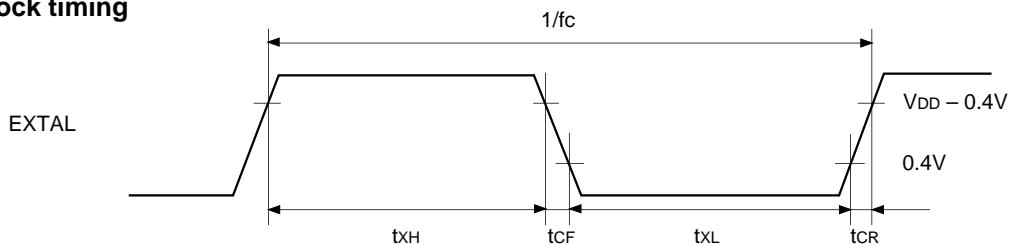

Fig.2. Clock applied conditions

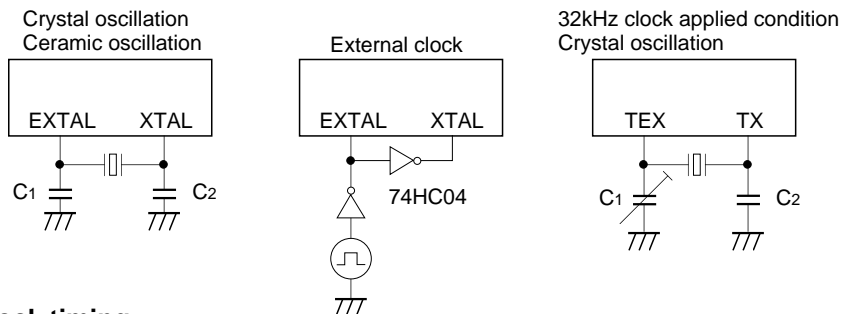
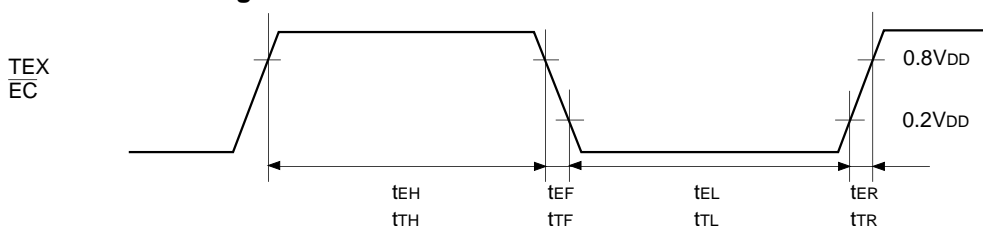

Fig. 3. Event count clock timing



(2) Serial transfer

($T_a = -20$ to $+75^\circ\text{C}$, $V_{DD} = 4.5$ to 5.5V , $V_{SS} = 0\text{V}$ reference)

Item	Symbol	Pins	Conditions	Min.	Max.	Unit
$\overline{\text{SCK}}$ cycle time	t_{KCY}	$\overline{\text{SCK}}$	Input mode	1000		ns
			Output mode	$8000/f_c$		ns
$\overline{\text{SCK}}$ High and Low level width	t_{KH}	$\overline{\text{SCK}}$	$\overline{\text{SCK}}$ input mode	400		ns
	t_{KL}		$\overline{\text{SCK}}$ output mode	$4000/f_c - 50$		ns
SI input setup time (for $\overline{\text{SCK}} \uparrow$)	t_{SIK}	SI	$\overline{\text{SCK}}$ input mode	100		ns
			$\overline{\text{SCK}}$ output mode	200		ns
SI hold time (for $\overline{\text{SCK}} \uparrow$)	t_{KSI}	SI	$\overline{\text{SCK}}$ input mode	200		ns
			$\overline{\text{SCK}}$ output mode	100		ns
$\overline{\text{SCK}} \downarrow \rightarrow \text{SO}$ delay time	t_{KSO}	SO	$\overline{\text{SCK}}$ input mode		200	ns
			$\overline{\text{SCK}}$ output mode		100	ns

Note) The load of $\overline{\text{SCK}}$ output mode and SO output delay time is $50\text{pF} + 1\text{TTL}$.

Fig. 4. Serial transfer timing

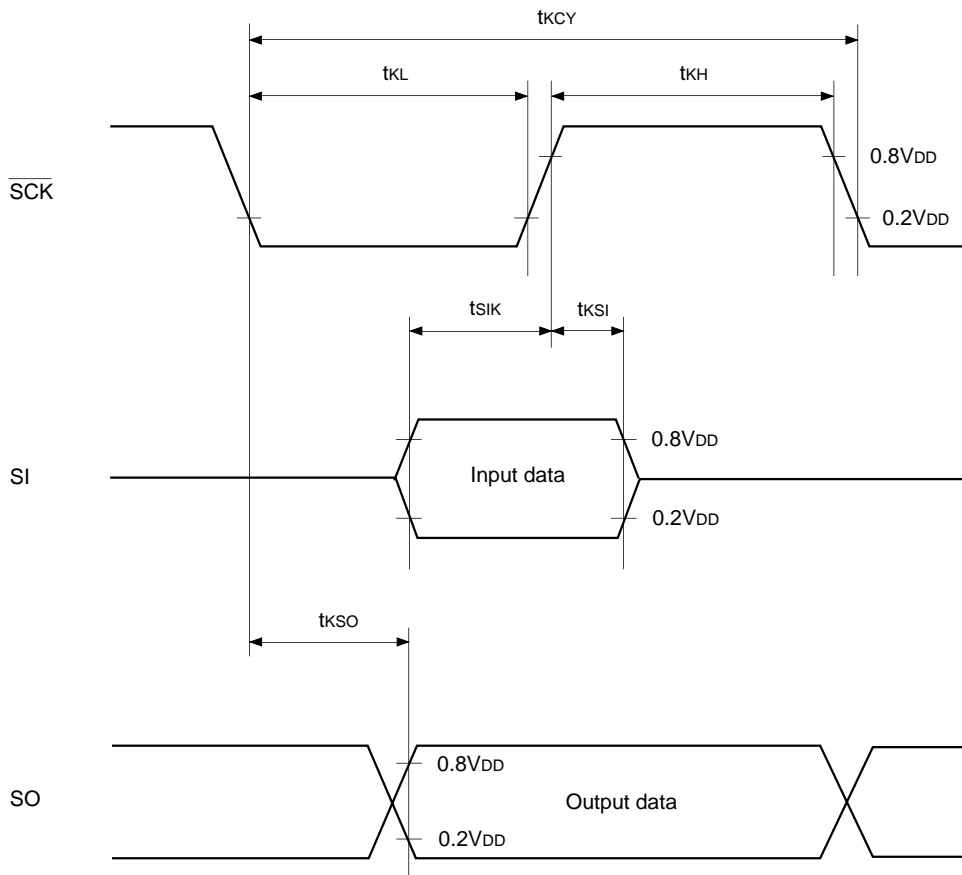

(3) A/D converter

(Ta = -20 to +75°C, VDD = 4.5 to 5.5V, Vss = 0V reference)

Item	Symbol	Pins	Conditions	Min.	Typ.	Max.	Unit
Resolution						8	Bits
Linearity error			Ta = 25°C VDD = 5.0V Vss = 0V			±3	LSB
Zero transition voltage	VZT*1			-10	10	70	mV
Full-scale transition voltage	VFT*2			4910	4970	5030	mV
Conversion time	tCONV			26/fADC*3			µs
Sampling time	tSAMP			6/fADC*3			µs
Analog input voltage	VIAN	AN0 to AN5		0		VDD	V

Fig. 5. Definitions of A/D converter terms

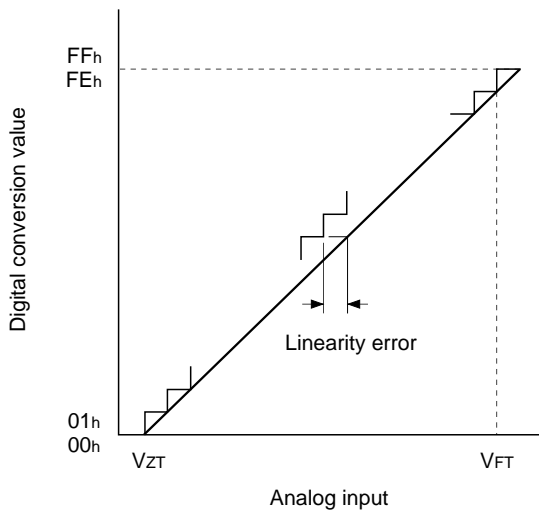

- *1 VZT: Value at which the digital conversion value changes from 00h to 01h and vice versa.
- *2 VFT: Value at which the digital conversion value changes from FEh to FFh and vice versa.
- *3 fADC indicates the below values due to the contents of bit 6 (CKS) of the A/D control register (ADC: 00F6h):

$$f_{ADC} = f_c \text{ (CKS = "0")}, f_c/2 \text{ (CKS = "1")}$$

(4) Interruption, reset input (Ta = -20 to +75°C, VDD = 4.5 to 5.5V, VSS = 0V reference)

Item	Symbol	Pins	Conditions	Min.	Max.	Unit
External interruption High, Low level width	t _{IH} t _{IL}	$\overline{\text{INT0}}$ $\overline{\text{INT1}}$ $\overline{\text{INT2}}$		1		μs
Reset input Low level width	t _{RSL}	$\overline{\text{RST}}$		32/fc		μs

Fig. 6. Interruption input timing

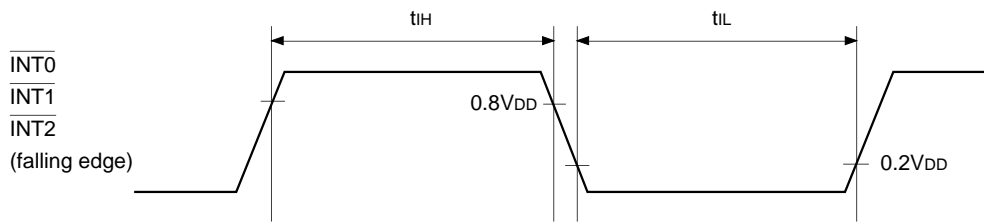
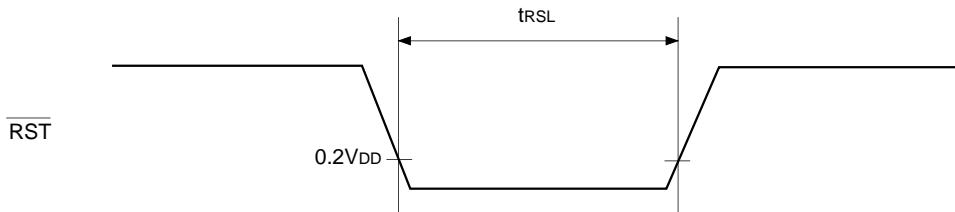

Fig. 7. $\overline{\text{RST}}$ input timing



(5) I²C bus timing

(Ta = -20 to +75°C, V_{DD} = 4.5 to 5.5V, V_{SS} = 0V reference)

Item	Symbol	Pins	Conditions	Min.	Max.	Unit
SCL clock frequency	f _{SCL}	SCL		0	100	kHz
Bus-free time before starting transfer	t _{BUF}	SDA, SCL		4.7		μs
Hold time for starting transfer	t _{HD; STA}	SDA, SCL		4.0		μs
Clock Low level width	t _{LOW}	SCL		4.7		μs
Clock High level width	t _{HIGH}	SCL		4.0		μs
Setup time for repeated transfers	t _{SU; STA}	SDA, SCL		4.7		μs
Data hold time	t _{HD; DAT}	SDA, SCL		0*1		μs
Data setup time	t _{SU; DAT}	SDA, SCL		250		ns
SDA, SCL rise time	t _R	SDA, SCL			1	μs
SDA, SCL fall time	t _F	SDA, SCL			300	ns
Setup time for transfer completion	t _{SU; STO}	SDA, SCL		4.7		μs

*1 The data hold time should be 300ns or more because the SCL rise time (300ns Max.) is not included in it.

Fig. 8. I²C bus transfer timing

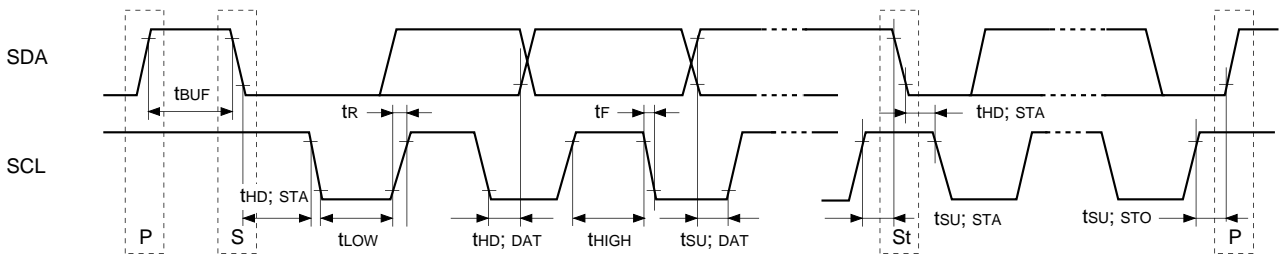
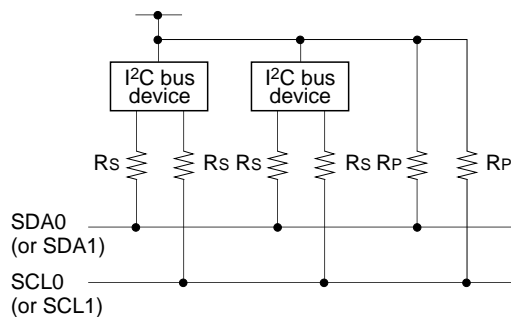

Fig. 9. I²C bus device recommended circuit



- A pull-up resistor (Rp) must be connected to SDA0 (or SDA1) and SCL0 (or SCL1).
- The SDA0 (or SDA1) and SCL0 (or SCL1) series resistance (Rs) can be used to reduce the spike noise caused by CRT flashover.

(6) OSD timing

(Ta = -20 to +75°C, VDD = 4.5 to 5.5V, VSS = 0V reference)

Item	Symbol	Pins	Conditions	Min.	Max	Unit
OSD clock frequency	fosc	EXLC XLC	Fig. 11	4	28*1	MHz
HSYNC pulse width	tHWD	HSYNC	Fig. 10	2		µs
VSYNC pulse width	tVWD	VSYNC	Fig. 10	1		H*2
HSYNC afterwrite rise and fall times	tHCG	HSYNC	Fig. 10		200	ns
VSYNC beforewrite rise and fall times	tVCG	VSYNC	Fig. 10		1.0	µs

*1 The maximum value of fosc is specified with the following equation.

$$fosc [max] \leq fc \times 1.9$$

*2 H indicates 1HSYNC period.

Fig. 10. OSD timing

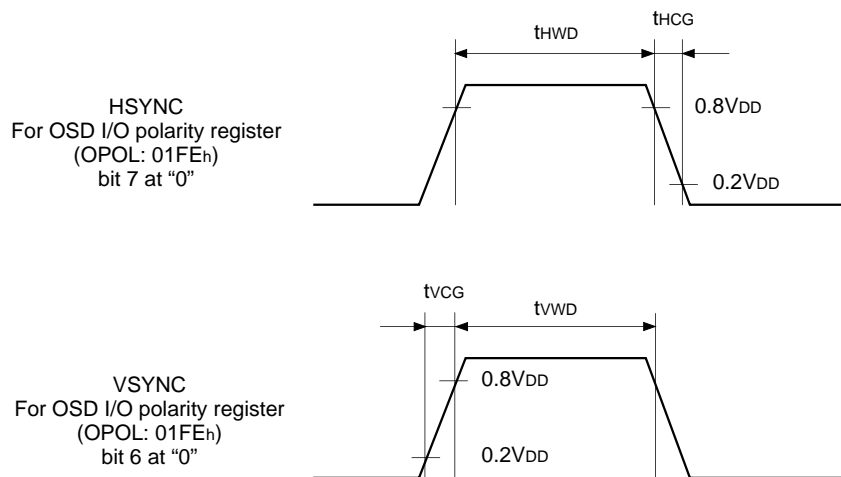
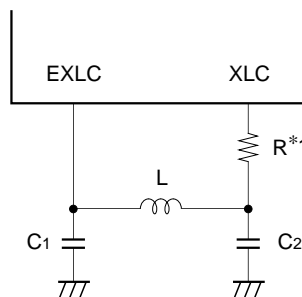

Fig. 11. LC oscillation circuit connection



*1 The series resistor for XLC is used to reduce the frequency of occurrence of the undesired radiation.

Appendix

Fig. 12. Recommended oscillation circuit

(i) Main clock

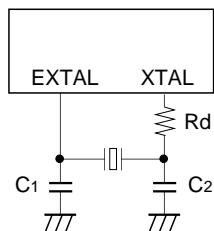

(ii) Main clock

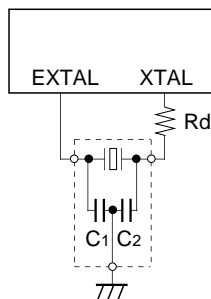

(iii) Sub clock

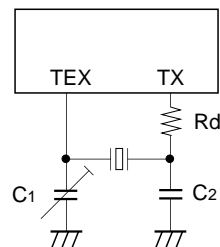

Manufacture	Model	fc (MHz)	C ₁ (pF)	C ₂ (pF)	Rd (Ω)	Circuit example
MURATA MFG CO., LTD	CSA10.0MTZ	10.0	30	30	0* ¹	(i)
	CSA12.0MTZ	12.0				
	CSA16.00MXZ040	16.0	5	5		
	CST10.0MTW*	10.0	30	30		(ii)
	CST12.0MTW*	12.0				
	CST16.00MXW0C1*	16.0	5	5		
RIVER ELETEC CO., LTD.	HC-49/U03	8.0	18	18	330* ¹	(i)
		12.0	12	12		
		16.0	10	10		
KINSEKI LTD.	HC-49/U (-S)	8.0	10	10	0* ¹	(i)
		12.0	5	5		
		16.0	OPEN	OPEN		
	P3	32.768kHz	30	33	120k	(iii)

* Models with an asterisk have the built-in ground capacitance (C₁, C₂).

*¹ The series resistor for XTAL can reduce the effect of the noise caused by the electrostatic discharge.

Mask Option Table

Item	Content	
Reset pin pull-up resistor	Non-existent	Existent

Fig. 13. Characteristic curves

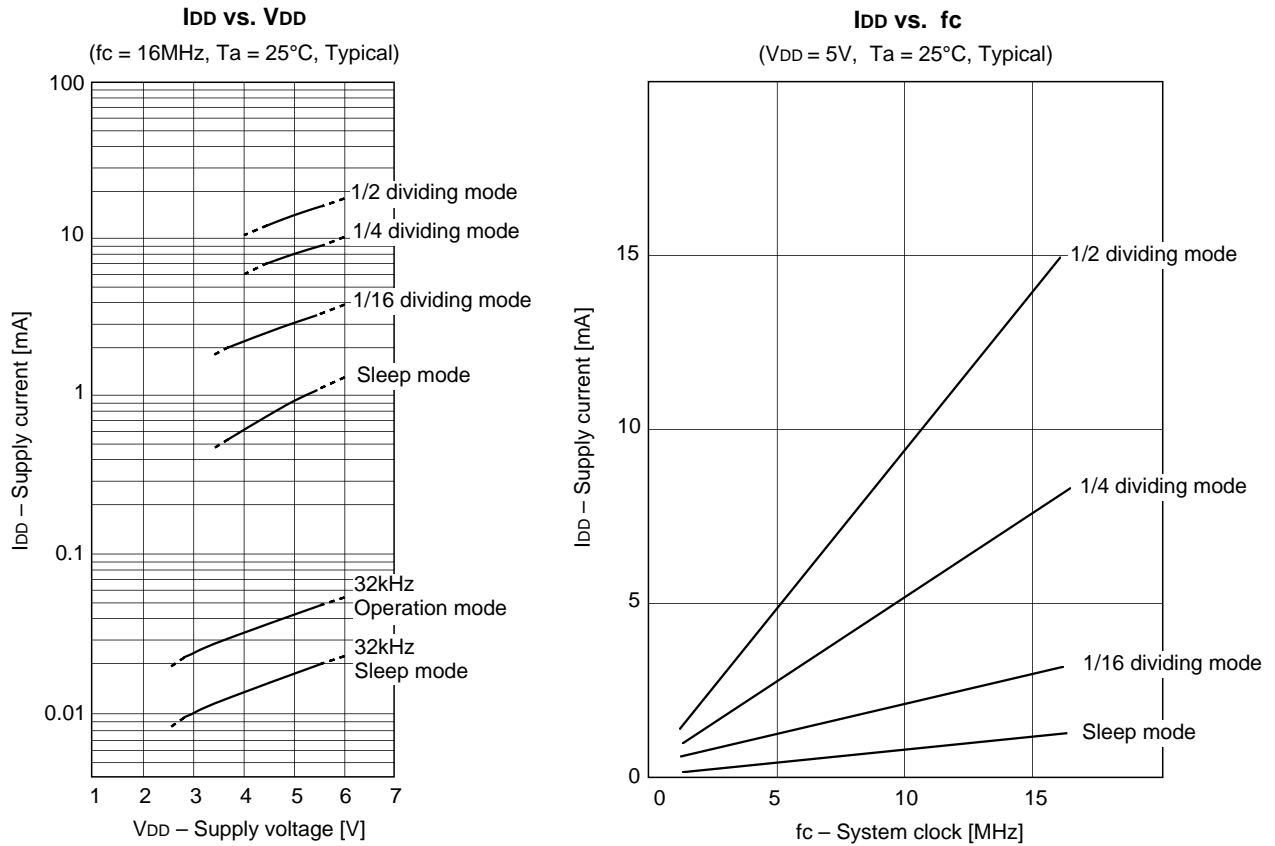

Parameter curve for OSD oscillation L vs. C
(theoretically calculated value)

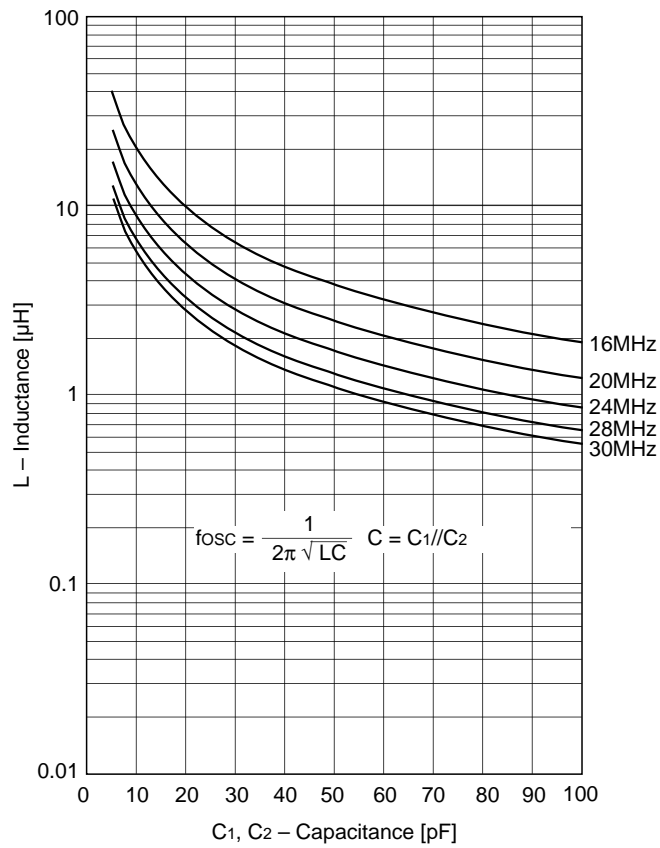

Package Outline

Unit: mm

52PIN SDIP (PLASTIC)

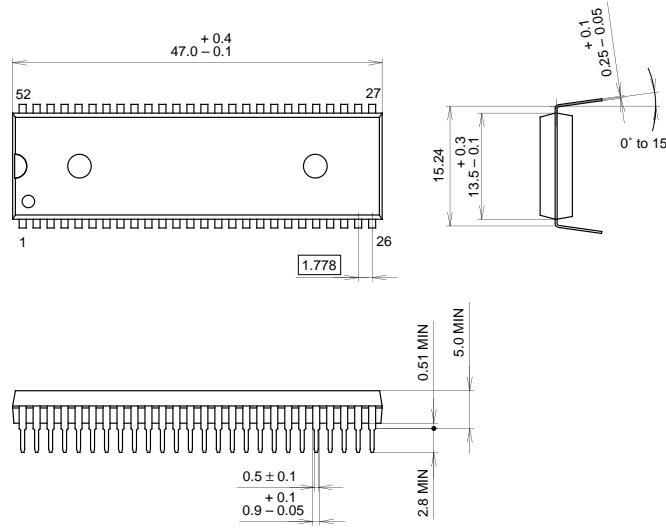

PACKAGE STRUCTURE

SONY CODE	SDIP-52P-01
EIAJ CODE	P-SDIP52-13.5x47.0-1.778
JEDEC CODE	_____

PACKAGE MATERIAL	EPOXY RESIN
LEAD TREATMENT	SOLDER PLATING
LEAD MATERIAL	COPPER ALLOY
PACKAGE MASS	5.6g

52PIN SDIP (PLASTIC)

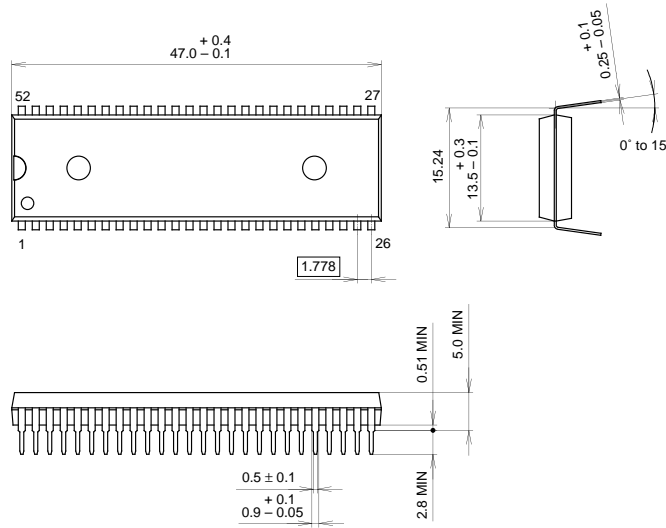

PACKAGE STRUCTURE

SONY CODE	SDIP-52P-01
EIAJ CODE	P-SDIP52-13.5x47.0-1.778
JEDEC CODE	_____

PACKAGE MATERIAL	EPOXY RESIN
LEAD TREATMENT	SOLDER PLATING
LEAD MATERIAL	COPPER ALLOY
PACKAGE MASS	5.6g

LEAD SPECIFICATIONS

ITEM	SPEC.
LEAD MATERIAL	COPPER ALLOY
LEAD TREATMENT	Sn-Bi 2.5%
LEAD TREATMENT THICKNESS	5-18µm



LittleDiode supplies new, hard to find or obsolete electronic components and semiconductors all over the world.

With over two million different components listed you are sure to find the part you need.

Feel free to visit us today at our online store:

LittleDiode.com

Looking forward to providing you with the best possible service.