

CMOS 8-bit Single Chip Microcomputer

Description

The CXP856P40 is a CMOS 8-bit microcomputer which consists of A/D converter, serial interface, timer/counter, time-base timer, closed caption decoder, data slicer, on-screen display function, I²C bus interface, PWM output, remote control reception circuit, HSYNC counter and watchdog timer as well as basic configuration like 8-bit CPU, PROM, RAM and I/O port.

Also this IC provides a power-on reset function and SLEEP function that enables to lower power consumption.

CXP856P40 is the PROM-incorporated version of the CXP85640 with built-in mask ROM. This provides the additional feature of being able to write directly into the program (also into the OSD character ROM or caption character ROM possible). Thus, it is most suitable for evaluation use during system development and for small-quantity production.

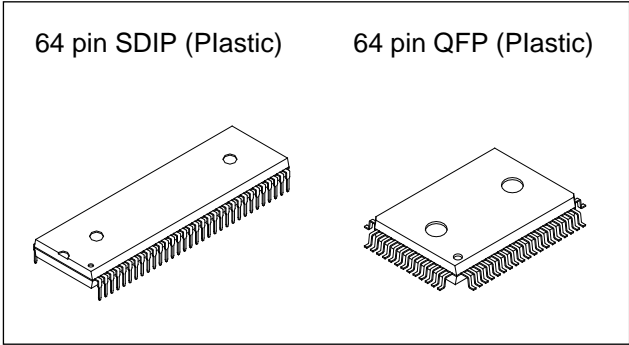

Structure

Silicon gate CMOS IC

Features

- A wide instruction set (213 instructions) to cover various types of data
 - 16-bit operation/multiplication and division/Boolean bit operation instructions
- Minimum instruction cycle 333ns at 12MHz operation
- Incorporated PROM 40K bytes (Programming)
 3K bytes (OSD)
 3K bytes (Caption)
- Incorporated RAM 1888 bytes (Excludes the closed caption decoder and on-screen display VRAM)
- Peripheral functions
 - A/D converter 8 bits, 6 channels, successive approximation method
 (Conversion time of 26.7µs/12MHz)
 - Serial interface 8-bit clock sync type, 1 channel
 - Timer 8-bit timer, 8-bit timer/counter, 19-bit time-base timer
 - Closed caption decoder
- On-screen display (OSD) function
 - Incorporated decode slicer,
 conforming to FCC, 8 × 13 dots, 192 character types, 15 character colors,
 4 lines × 34 characters, italic, underline, vertical scrolling,
 15 frame background colors/half blanking
 - 12 × 16 dots, 128 character types, 15 character colors, 4 lines × 24 characters,
 edging (half dot) vertical scrolling for every line
 8 frame background colors/half blanking, jitter elimination circuit
- I²C bus interface
- PWM output 8 bits, 4 channels
- Remote control receiver circuit
- 8-bit pulse measurement counter, 6-stage FIFO
- HSYNC counter 2 channels
- Watchdog timer
- Interruption 15 factors, 15 vectors, multi-interruption possible
- Standby mode Sleep
- Package 64-pin plastic SDIP/QFP

Purchase of Sony's I²C components conveys a license under the Philips I²C Patent Rights to use these components in an I²C system, provided that the system conform to the I²C Standard Specifications as defined by Philips.

Sony reserves the right to change products and specifications without prior notice. This information does not convey any license by any implication or otherwise under any patents or other right. Application circuits shown, if any, are typical examples illustrating the operation of the devices. Sony cannot assume responsibility for any problems arising out of the use of these circuits.

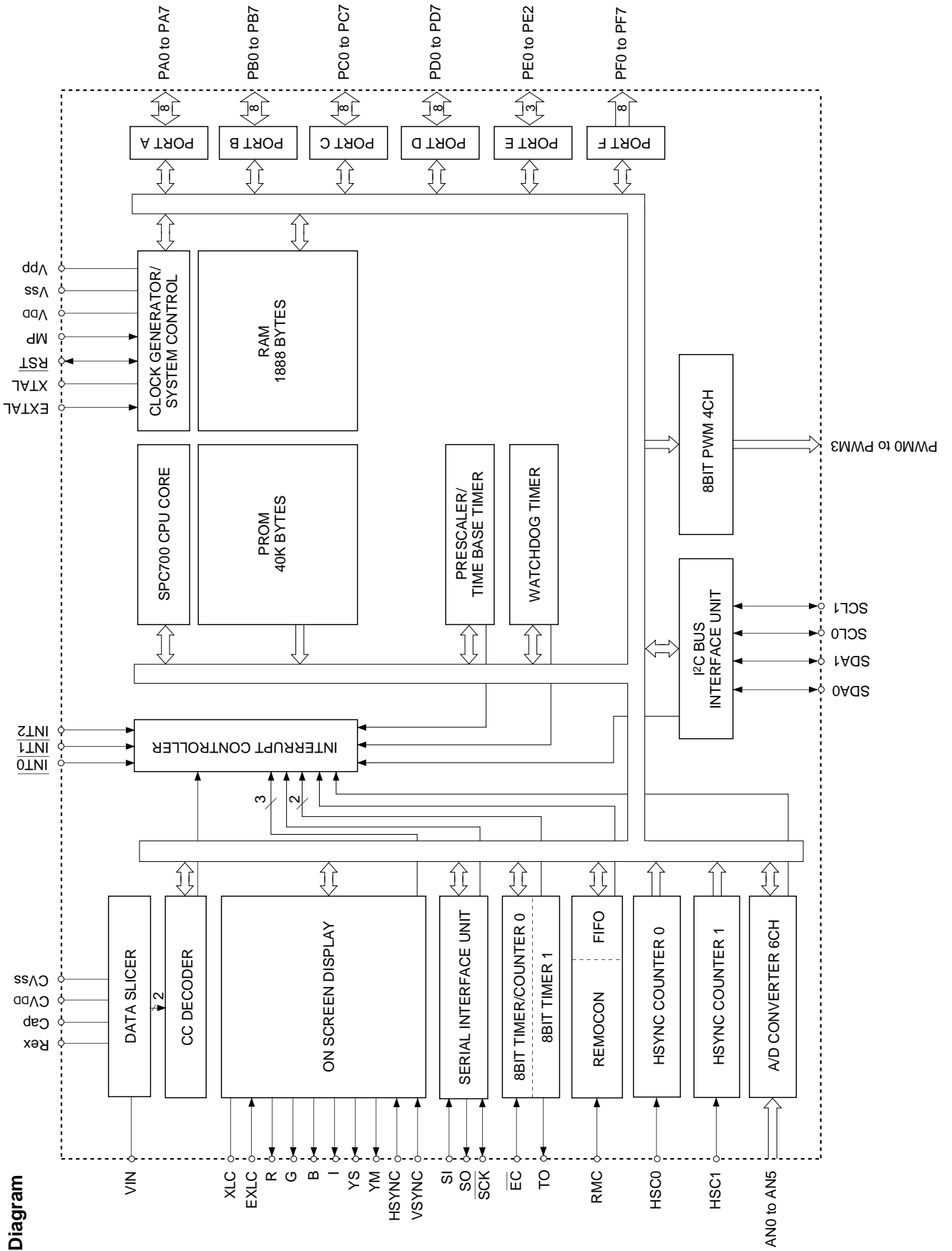

Block Diagram

Pin Assignment (Top View) 64-pin SDIP

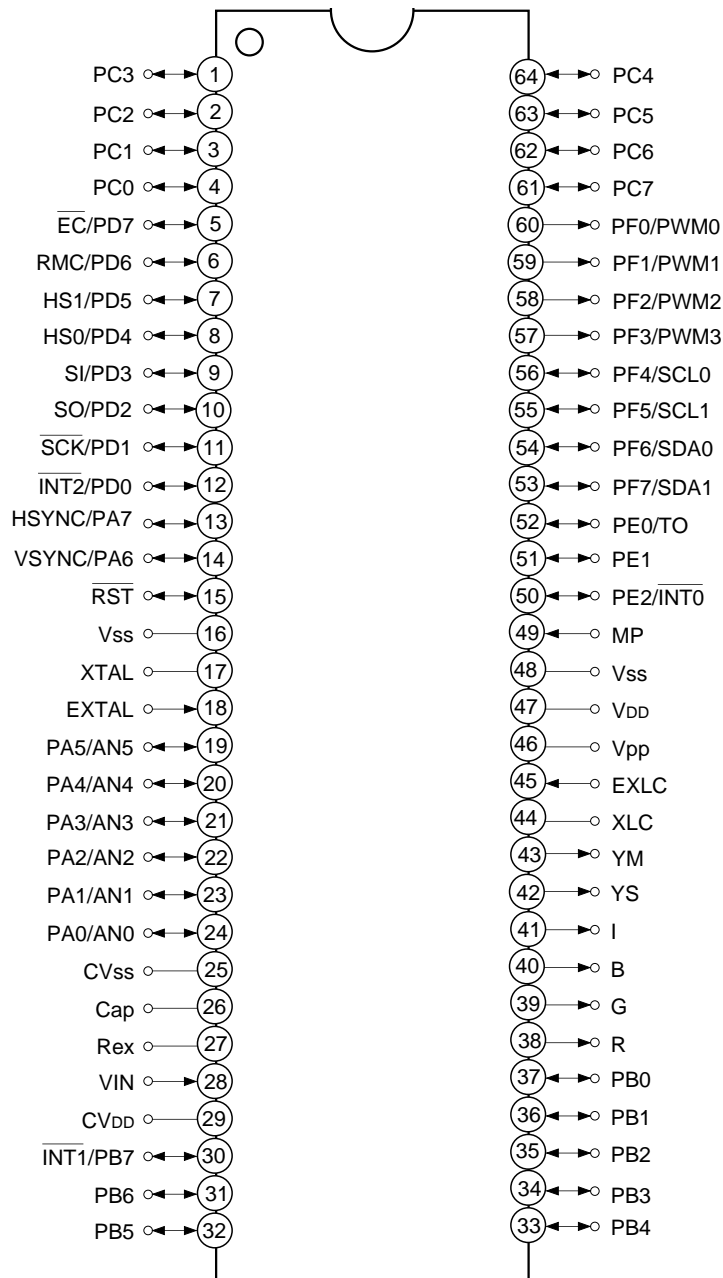

- Note)**
1. Vpp (Pin 46) must be connected to VDD.
 2. Vss (Pins 16 and 48) must be connected to GND.
 3. MP (Pin 49) must be connected to GND.
 4. Cap (Pin 26) must be connected to CVss via a capacitor.
 5. Rex (Pin 27) must be connected to CVDD via a resistor of 33kΩ.

Pin Assignment (Top View) 64-pin QFP

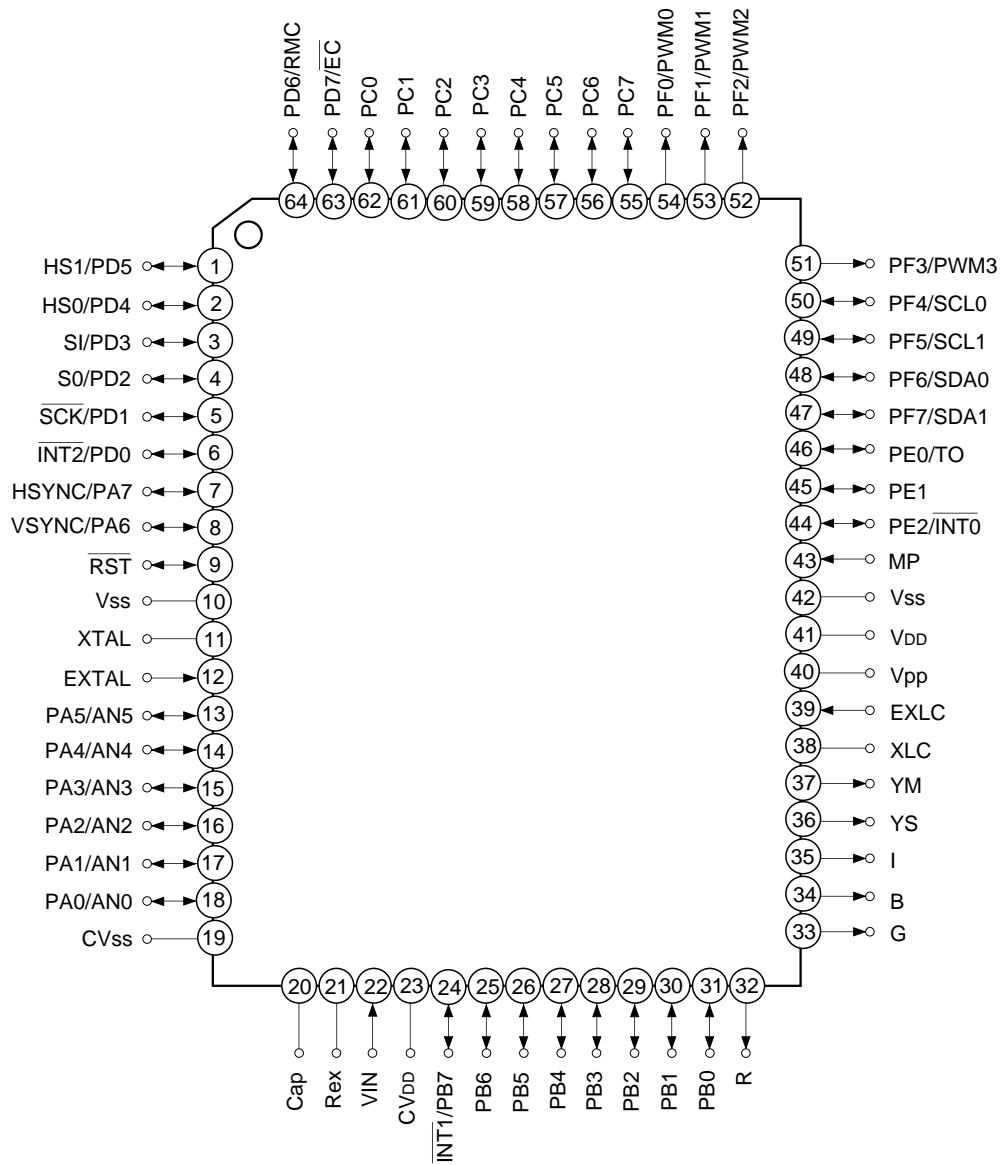

- Note**
1. Vpp (Pin 40) must be connected to VDD.
 2. Vss (Pins 10 and 42) must be connected to GND.
 3. MP (Pin 43) must be connected to GND.
 4. Cap (Pin 20) must be connected to CVss via a capacitor.
 5. Rex (Pin 21) must be connected to CVDD via a resistor of 33kΩ.

Pin Description

Symbol	I/O	Description	
PA0/AN0 to PA5/AN5	I/O/Analog input	(Port A) 8-bit I/O port. I/O can be set in a unit of single bits. (8 pins)	Analog inputs to A/D converter. (6 pins)
PA6/VSYNC	I/O/Input		OSD display vertical sync signal input.
PA7/HSYNC	I/O/Input		OSD display horizontal sync signal input.
PB0 to PB6	I/O	(Port B) 8-bit I/O port. I/O can be set in a unit of single bits. (8 pins)	
PB7/ $\overline{\text{INT1}}$	I/O/Input		External interruption request input. Active at the falling edge.
PC0 to PC7	I/O	(Port C) 8-bit I/O port. I/O can be set in a unit of single bits. (8 pins)	
PD0/ $\overline{\text{INT2}}$	I/O/Input	(Port D) 8-bit I/O port. I/O can be set in a unit of single bits. Can drive 12mA sync current. (8 pins)	External interruption request input. Active at the falling edge.
PD1/ $\overline{\text{SCK}}$	I/O/I/O		Serial clock I/O.
PD2/SO	I/O/Output		Serial data output.
PD3/SI	I/O/Input		Serial data input.
PD4/HS0	I/O/Input		HSYNC counter (CH0) input.
PD5/HS1	I/O/Input		HSYNC counter (CH1) input.
PD6/RMC	I/O/Input		Remote control reception circuit input.
PD7/ $\overline{\text{EC}}$	I/O/Input		External event input for timer/counter.
PE0/TO	I/O/Output		(Port E) 3-bit I/O port. I/O can be set in a unit of single bits. (3 pins)
PE1	I/O		
PE2/ $\overline{\text{INT0}}$	I/O/Input	Input for external interruption request. Active at the falling edge.	
PF0/PWM0 to PF3/PWM3	Output/Output	(Port F) 8-bit output port with large current (12mA) N-ch open drain output. Lower 4 bits are 12V drive and upper 4 bits are 5V drive. (8 pins)	8-bit PWM outputs. (4 pins)
PF4/SCL0 PF5/SCL1	Output/I/O		Transfer clock I/O for I ² C bus interface. (2 pins)
PF6/SDA0 PF7/SDA1	Output/I/O		Transfer data I/O for I ² C bus interface. (2 pins)
R, G, B, I, YS, YM	Output	6-bit OSD display outputs. (6 pins)	

Symbol	I/O	Description
EXLC	Input	OSD display clock oscillation I/O. Oscillator frequency is determined by the external L and C.
XLC	Output	
VIN	Input	External composite video signal input. Input a 2Vp-p signal via a capacitor.
Cap	—	Connects a capacitor for the data slicer between Cap and CVss.
Rex	—	Connects a 33kΩ resistor for the data slicer between Rex and CVDD.
CVDD		Positive power supply for data slicer.
CVss		GND for data slicer.
EXTAL	Input	Connects a crystal for system clock oscillation. When an external clock is supplied, input it to EXTAL and leave XTAL open.
XTAL	Output	
$\overline{\text{RST}}$	I/O	System reset; active at Low level I/O pin. Outputs a Low level when the power is turned on and the power-on reset function operates.
MP	Input	Test mode input. Must be connected to GND.
Vpp		Positive power supply for internal PROM writing. Under normal conditions, connect to VDD.
VDD		Positive power supply.
Vss		GND. Connect two Vss pins to GND.

Input/Output Circuit Formats for Pins

Pin	Circuit format	When reset
<p>PA0/AN0 to PA5/AN5</p> <p>6 pins</p>	<p>Port A</p> <p>Port A data</p> <p>Port A direction "0" when reset</p> <p>Data bus</p> <p>RD (Port A)</p> <p>Port A function selection "0" when reset A/D converter</p> <p>Input multiplexer</p> <p>IP Input protection circuit</p>	<p>Hi-Z</p>
<p>PA6/VSYNC PA7/HSYNC</p> <p>2 pins</p>	<p>Port A</p> <p>Port A data</p> <p>Port A direction "0" when reset</p> <p>Data bus</p> <p>RD (Port A)</p> <p>VSYNC, HSYNC</p> <p>Schmitt input</p> <p>Input polarity "0" when reset</p> <p>IP</p>	<p>Hi-Z</p>
<p>PB0 to PB6 PB7/INT1 PC0 to PC7</p> <p>16 pins</p>	<p>Port B Port C</p> <p>Port B, C data</p> <p>Port B, C direction "0" when reset</p> <p>Data bus</p> <p>RD (Port B, C)</p> <p>INT1</p> <p>Schmitt input</p> <p>IP</p>	<p>Hi-Z</p>

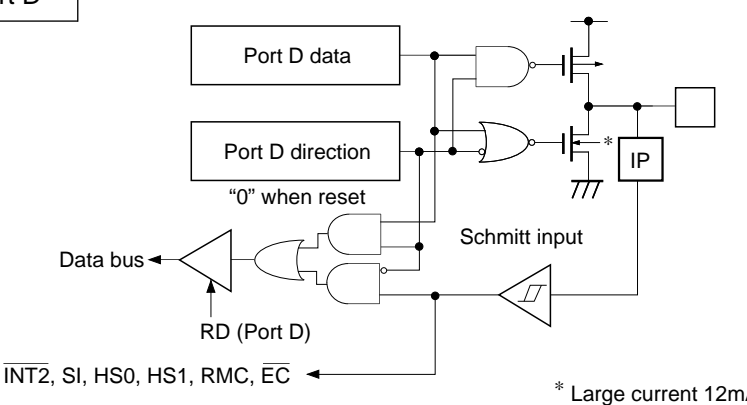
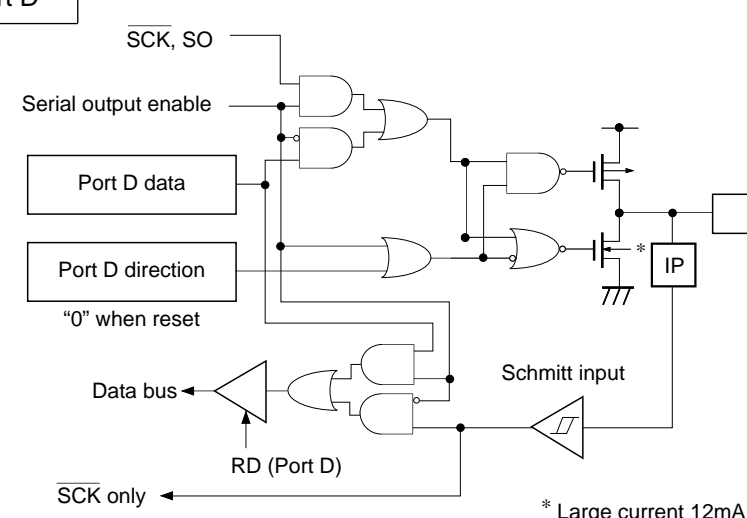
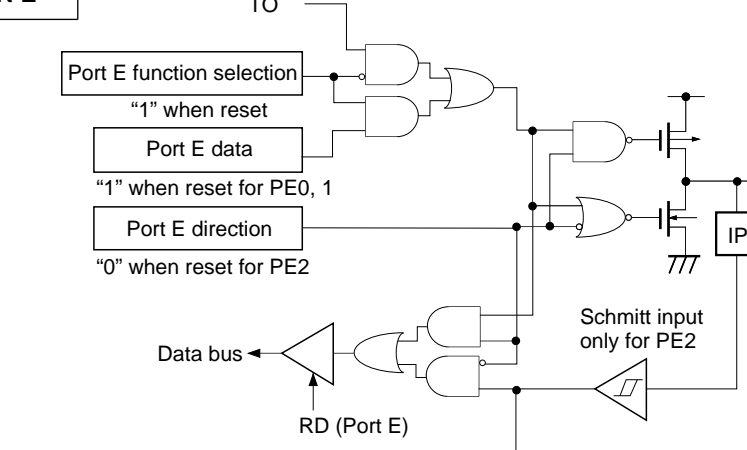
Pin	Circuit format	When reset
<p>PD0/$\overline{\text{INT2}}$ PD3/SI PD4/HS0 PD5/HS1 PD6/RMC PD7/$\overline{\text{EC}}$</p> <p>6 pins</p>	<p>Port D</p>  <p>* Large current 12mA</p>	<p>Hi-Z</p>
<p>PD1/$\overline{\text{SCK}}$ PD2/SO</p> <p>2 pins</p>	<p>Port D</p>  <p>* Large current 12mA</p>	<p>Hi-Z</p>
<p>PE0/TO PE1 PE2/$\overline{\text{INT0}}$</p> <p>3 pins</p>	<p>Port E</p>  <p>Schmitt input only for PE2</p>	<p>PE0, PE1: High level PE2: Hi-Z</p>

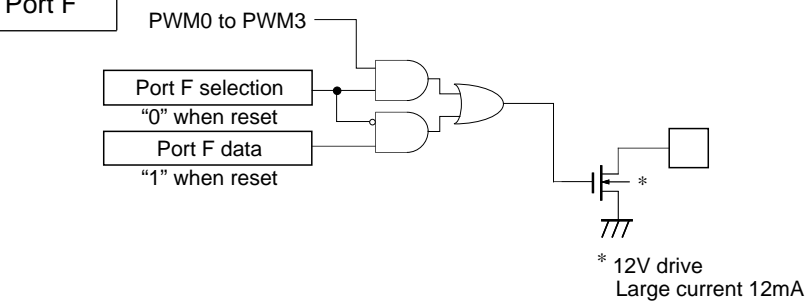
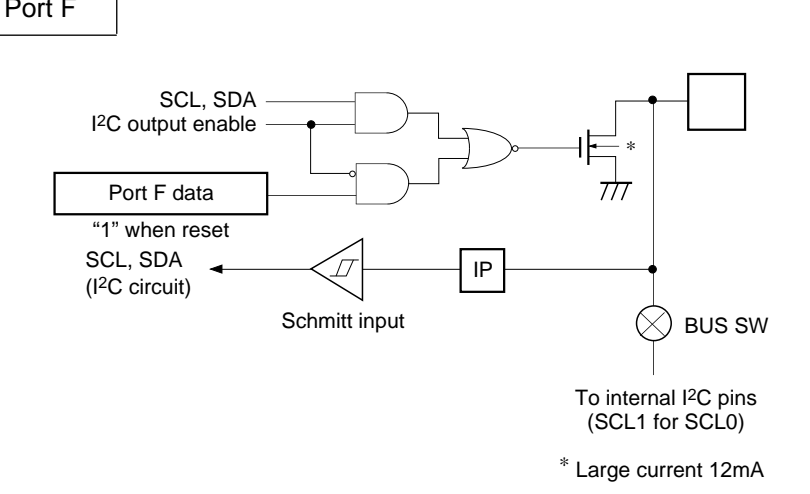
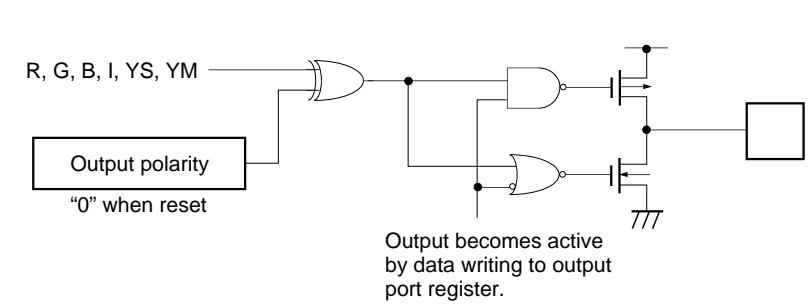
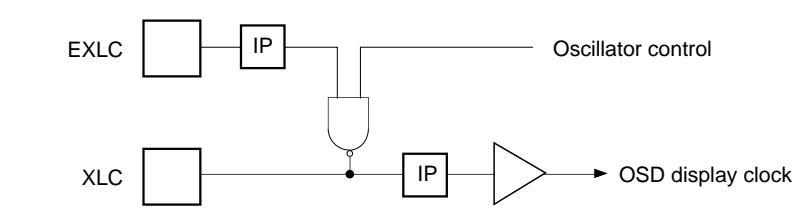
Pin	Circuit format	When reset
<p>PF0/PWM0 to PF3/PWM3</p> <p>4 pins</p>	<p>Port F</p>  <p>* 12V drive Large current 12mA</p>	<p>Hi-Z</p>
<p>PF4/SCL0 PF5/SCL1 PF6/SDA0 PF7/SDA1</p> <p>4 pins</p>	<p>Port F</p>  <p>* Large current 12mA</p>	<p>Hi-Z</p>
<p>R G B I YS YM</p> <p>6 pins</p>	 <p>Output becomes active by data writing to output port register.</p>	<p>Hi-Z</p>
<p>EXLC XLC</p> <p>2 pins</p>	 <p>Oscillator control</p> <p>OSD display clock</p>	<p>Oscillation halted</p>

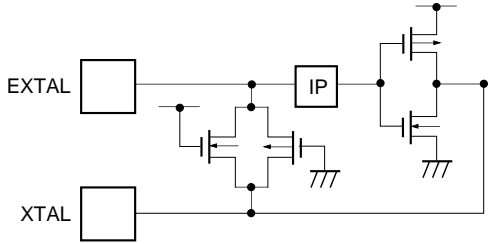
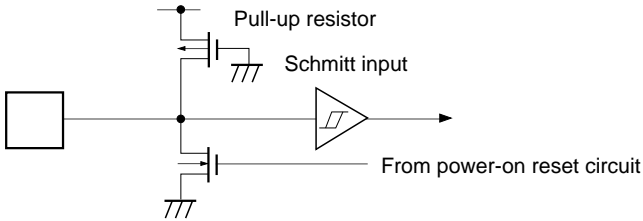
Pin	Circuit format	When reset
<p>EXTAL XTAL</p> <p>2 pins</p>	 <ul style="list-style-type: none"> • Diagram shows the circuit composition during oscillation. • Feedback resistor is removed during stop. (This device does not enter the STOP mode.) 	<p>Oscillation</p>
<p>$\overline{\text{RST}}$</p> <p>1 pin</p>	 <p>Pull-up resistor</p> <p>Schmitt input</p> <p>From power-on reset circuit</p>	<p>Low level</p>

Absolute Maximum Ratings

(V_{SS} = 0V reference)

Item	Symbol	Ratings	Unit	Remarks
Supply voltage	V _{DD}	-0.3 to +7.0	V	
	V _{pp}	-0.3 to +13.0	V	Incorporated PROM
Input voltage	V _{IN}	-0.3 to +7.0* ¹	V	
Output voltage	V _{OUT}	-0.3 to +7.0* ¹	V	
Mid-voltage drive output voltage	V _{OUTP}	-0.3 to +15.0	V	PF0 to PF3 pins
High level output current	I _{OH}	-5	mA	
High level total output current	ΣI _{OH}	-50	mA	Total of all output pins
Low level output current	I _{OL}	15	mA	Ports excluding large current output (value per pin)
	I _{OLC}	20	mA	Large current output port (value per pin)* ²
Low level total output current	ΣI _{OL}	100	mA	Total of all output pins
Operating temperature	T _{opr}	-10 to +75	°C	
Storage temperature	T _{stg}	-55 to +150	°C	
Allowable power dissipation	P _D	1000	mW	SDIP
		600	mW	QFP

*¹ V_{IN} and V_{OUT} should not exceed V_{DD} + 0.3V.

*² The large current output port is Port D (PD) and Port F (PF).

Note) Usage exceeding absolute maximum ratings may permanently impair the LSI. Normal operation should be conducted under the recommended operating conditions. Exceeding those conditions may adversely affect the reliability of the LSI.

Recommended Operating Conditions

(V_{SS} = 0V reference)

Item	Symbol	Min.	Max.	Unit	Remarks
Supply voltage	V _{DD}	4.5	5.5	V	Guaranteed operation range for 1/2 and 1/4 frequency dividing modes
		3.5	5.5	V	Guaranteed operation range for 1/16 frequency dividing mode or sleep mode
		2.5	5.5	V	Guaranteed data hold range for stop mode* ¹
	V _{pp}	V _{pp} = V _{DD}		V	* ⁶
Data slicer supply voltage	CV _{DD}	4.5	5.5	V	* ⁵
High level input voltage	V _{IH}	0.7V _{DD}	V _{DD}	V	* ²
	V _{IHS}	0.8V _{DD}	V _{DD}	V	* ³
	V _{IHEX}	V _{DD} - 0.4	V _{DD} + 0.3	V	EXTAL pin* ⁴
Low level input voltage	V _{IL}	0	0.3V _{DD}	V	* ²
	V _{ILS}	0	0.2V _{DD}	V	* ³
	V _{ILEX}	-0.3	0.4	V	EXTAL pin* ⁴
Operating temperature	T _{opr}	-10	+75	°C	

*¹ This device does not enter the STOP mode.

*² PA, PB, PC, PE0 to PE1, SCL0 to SCL1, SDA0 to SDA1 pins.

*³ INT2, SCK, SO, SI, HS0, HS1, RMC, EC, INT1, HSYNC, VSYNC, RST pins.

*⁴ Specifies only during external clock input.

*⁵ CV_{DD} and V_{DD} should be set to the same voltage.

*⁶ V_{pp} and V_{DD} should be set to the same voltage.

DC Characteristics

(Ta = -10 to +75°C, Vss = 0V reference)

Item	Symbol	Pin	Condition	Min.	Typ.	Max.	Unit
High level output voltage	V _{OH}	PA to PD, PE, R, G, B, I, YS, YM	V _{DD} = 4.5V, I _{OH} = -0.5mA	4.0			V
			V _{DD} = 4.5V, I _{OH} = -1.2mA	3.5			V
Low level output voltage	V _{OL}	PA to PD, PE, R, G, B, I, YS, YM, PF0 to PF3, RST*1	V _{DD} = 4.5V, I _{OL} = 1.8mA			0.4	V
			V _{DD} = 4.5V, I _{OL} = 3.6mA			0.6	V
		PD, PF	V _{DD} = 4.5V, I _{OL} = 12.0mA			1.5	V
		PF4 to PF7 (SCL0, SCL1, SDA0, SDA1)	V _{DD} = 4.5V, I _{OL} = 3.0mA			0.4	V
			V _{DD} = 4.5V, I _{OL} = 4.0mA			0.6	V
Input current	I _{IHE}	EXTAL	V _{DD} = 5.5V, V _{IH} = 5.5V	0.5		40	μA
	I _{IHL}		V _{DD} = 5.5V, V _{IL} = 0.4V	-0.5		-40	μA
	I _{ILR}	RST*2	V _{DD} = 5.5V, V _{IL} = 0.4V	-1.5		-400	μA
I/O leakage current	I _{Iz}	PA to PE, HSYNC, VSYNC, R, G, B, I, YS, YM, RST*2	V _{DD} = 5.5V, V _I = 0, 5.5V			±10	μA
Open drain output leak current (in N-ch Tr off state)	I _{LOH}	PF0 to PF3	V _{DD} = 5.5V, V _{OH} = 12.0V			50	μA
		PF4 to PF7	V _{DD} = 5.5V, V _{OH} = 5.5V			10	μA
I ² C bus switch connection impedance (in output Tr off state)	R _{BS}	SCL0: SCL1 SDA0: SDA1	V _{DD} = 4.5V V _{SCL0} = V _{SCL1} = 2.25V V _{SDA0} = V _{SDA1} = 2.25V			120	Ω
Supply current	I _{DD}	V _{DD} *3	1/2 frequency dividing mode V _{DD} = 5.5V 12MHz crystal oscillation (C ₁ = C ₂ = 15pF)		40	50	mA
	I _{DDSL}		Sleep mode V _{DD} = 5.5V 12MHz crystal oscillation (C ₁ = C ₂ = 15pF)		1.0	5	mA
	I _{DDST}		Stop mode*4 V _{DD} = 5.5V 12MHz crystal oscillation	—	—	—	μA
	I _{CVDD}		CV _{DD}	V _{DD} = 5.5V	—	5.0	10.0
Input capacitance	C _{IN}	PA to PE, SCL, SDA, EXLC, EXTAL, VIN, RST	1MHz clock 0V for no-measured pins		10	20	pF

*1 Specifies $\overline{\text{RST}}$ pin only when the power-on reset circuit is selected with mask option.

*2 For $\overline{\text{RST}}$ pin, specifies the input current when pull-up resistance is selected, and specifies the leakage current when non-resistance is selected.

*3 When all output pins are left open. Specifies only when the OSD oscillation is halted.

*4 This device does not enter the stop mode.

AC Characteristics

(1) Clock timing

(Ta = -10 to +75°C, VDD = 4.5 to 5.5V, Vss = 0V reference)

Item	Symbol	Pin	Condition	Min.	Typ.	Max.	Unit
System clock frequency	fc	XTAL EXTAL	Fig. 1, Fig. 2		12.0		MHz
System clock input pulse width	t _{XL} , t _{XH}	EXTAL	Fig. 1, Fig. 2 External clock drive	37.5			ns
System clock rise and fall times	t _{CR} , t _{CF}	EXTAL	Fig 1, Fig 2 External clock drive			200	ns
Event counter input clock pulse width	t _{EH} , t _{EL}	\overline{EC}	Fig. 3	t _{sys} *1 + 50			ns
Event counter input clock rise and fall times	t _{ER} , t _{EF}	\overline{EC}	Fig. 3			20	ms

*1 Indicates three values according to the contents of the clock control register (CLC: 00FEH) upper 2 bits (CPU clock selection).

t_{sys} (ns) = 2000/fc (Upper 2 bits = "00"), 4000/fc (Upper 2 bits = "01"), 16000/fc (Upper 2 bits = "11")

Fig. 1. Clock timing

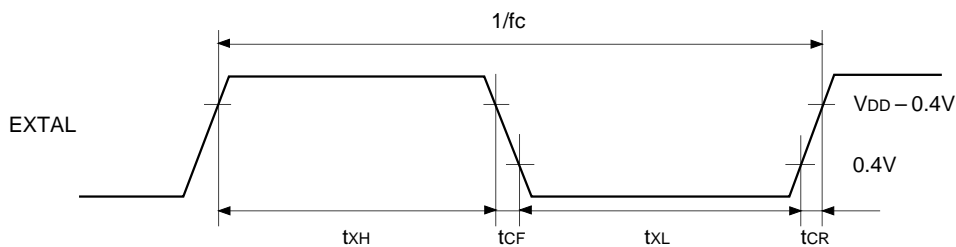

Fig. 2. Clock applied condition

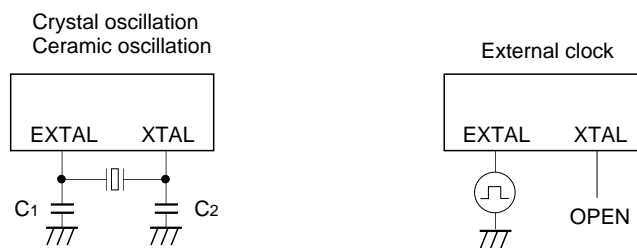
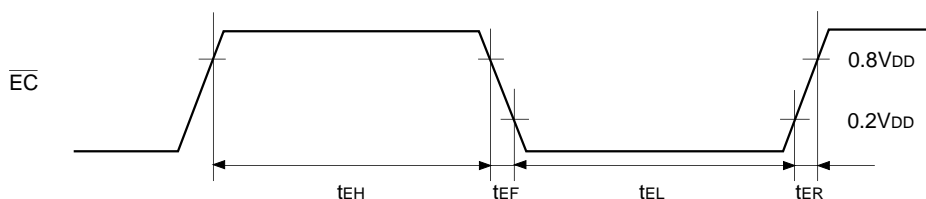

Fig. 3. Event count clock timing



(2) Serial transfer

($T_a = -10$ to $+75^\circ\text{C}$, $V_{DD} = 4.5$ to 5.5V , $V_{SS} = 0\text{V}$ reference)

Item	Symbol	Pin	Condition	Min.	Max.	Unit
$\overline{\text{SCK}}$ cycle time	t_{KCY}	$\overline{\text{SCK}}$	Input mode	1000		ns
			Output mode	$8000/f_c$		ns
$\overline{\text{SCK}}$ high and low level widths	t_{KH}	$\overline{\text{SCK}}$	$\overline{\text{SCK}}$ input mode	400		ns
	t_{KL}		$\overline{\text{SCK}}$ output mode	$4000/f_c - 50$		ns
SI input set-up time (for $\overline{\text{SCK}} \uparrow$)	t_{SIK}	SI	$\overline{\text{SCK}}$ input mode	100		ns
			$\overline{\text{SCK}}$ output mode	200		ns
SI input hold time (for $\overline{\text{SCK}} \uparrow$)	t_{KSI}	SI	$\overline{\text{SCK}}$ input mode	200		ns
			$\overline{\text{SCK}}$ output mode	100		ns
$\overline{\text{SCK}} \downarrow \rightarrow \text{SO}$ delay time	t_{KSO}	SO	$\overline{\text{SCK}}$ input mode		200	ns
			$\overline{\text{SCK}}$ output mode		100	ns

Note) The load of $\overline{\text{SCK}}$ output mode and SO output delay time is $50\text{pF} + 1\text{TTL}$.

Fig. 4. Serial transfer timing

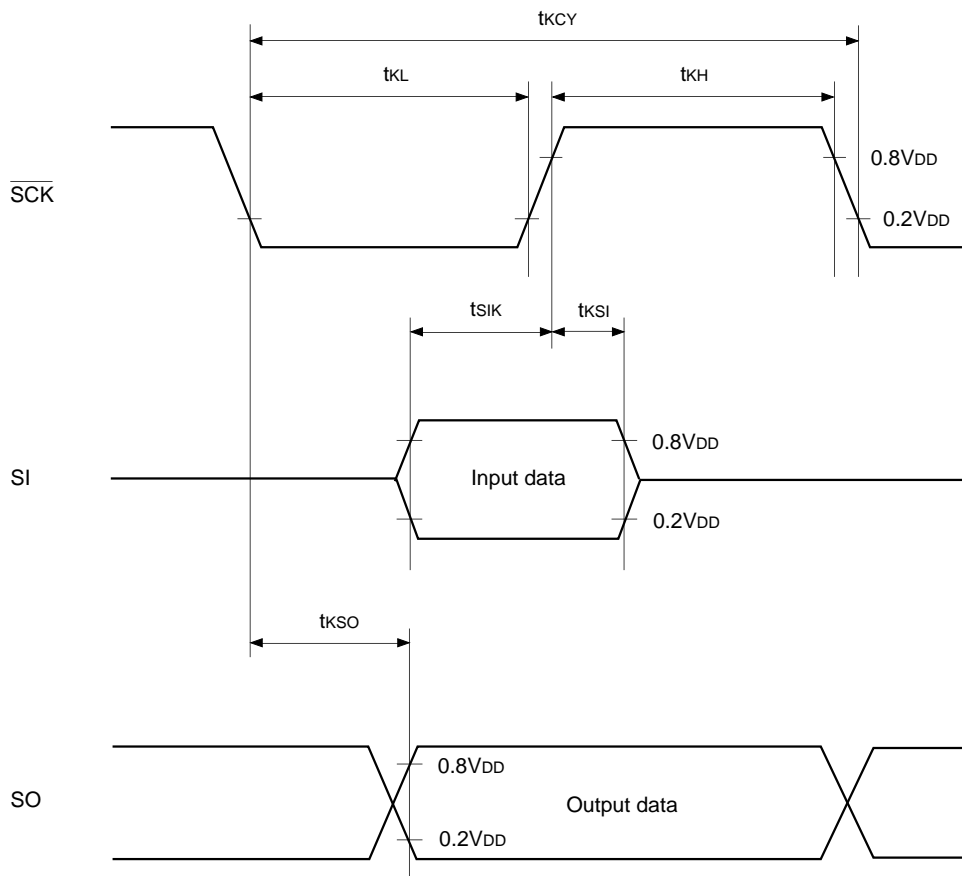

(3) A/D converter characteristics

($T_a = -10$ to $+75^\circ\text{C}$, $V_{DD} = 4.5$ to 5.5V , $V_{SS} = 0\text{V}$ reference)

Item	Symbol	Pin	Condition	Min.	Typ.	Max.	Unit
Resolution						8	Bits
Linearity error			$T_a = 25^\circ\text{C}$ $V_{DD} = 5.0\text{V}$ $V_{SS} = 0\text{V}$			± 3	LSB
Zero transition voltage	V_{ZT}^{*1}			-50	10	70	mV
Full-scale transition voltage	V_{FT}^{*2}			4910	4970	5030	mV
Conversion time	t_{CONV}			$160/f_{ADC}^{*3}$			μs
Sampling time	t_{SAMP}			$12/f_{ADC}^{*3}$			μs
Analog input voltage	V_{IAN}	AN0 to AN5		0		V_{DD}	V

Fig. 5. Definitions for A/D converter terms

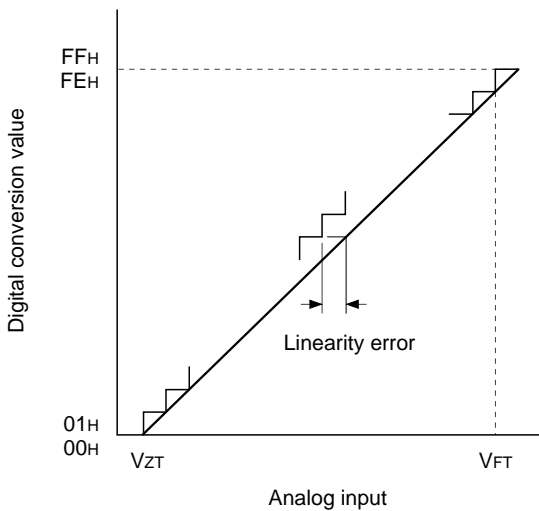

- *1 Value at which the digital conversion value changes from 00H to 01H and vice versa.
- *2 Value at which the digital conversion value changes from FEH to FFH and vice versa.
- *3 f_{ADC} indicates the below values due to the contents of bit 6 (CKS) of the A/D control register (ADC: 00F9H) and bits 7 (PCK1) and 6 (PCK0) of the clock control register (CLC: 00FEH).

PCK1, 0	CKS	
	0 ($\phi/2$ selection)	1 (ϕ selection)
00 ($\phi = f_{EX}/2$)	$f_{ADC} = f_c/2$	$f_{ADC} = f_c$
01 ($\phi = f_{EX}/4$)	$f_{ADC} = f_c/4$	$f_{ADC} = f_c/2$
11 ($\phi = f_{EX}/16$)	$f_{ADC} = f_c/16$	$f_{ADC} = f_c/8$

(4) Interruption, reset input (Ta = -10 to +75°C, VDD = 4.5 to 5.5V, Vss = 0V reference)

Item	Symbol	Pin	Condition	Min.	Max.	Unit
External interruption High and Low level widths	t _{IH}	$\overline{\text{INT0}}$		1		μs
	t _{IL}	$\overline{\text{INT1}}$ $\overline{\text{INT2}}$				
Reset input Low level width	t _{RSL}	$\overline{\text{RST}}$		32/fc		μs

Fig. 6. Interruption input timing

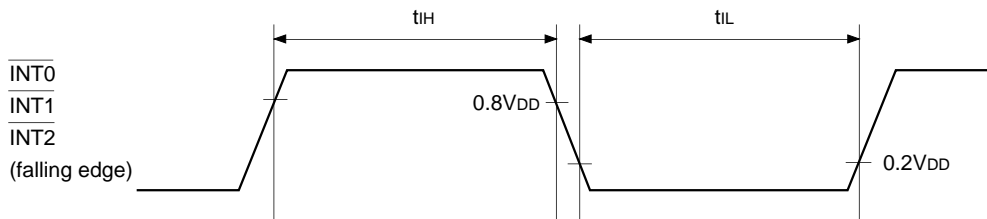
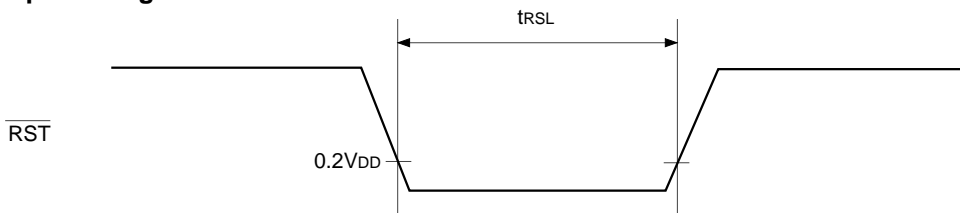

Fig. 7. RST input timing



(5) Power-on reset (Ta = -10 to +75°C, Vss = 0V reference)

Item	Symbol	Pin	Condition	Min.	Max.	Unit
Power supply rise time	t _R	V _{DD}	Power-on reset	0.05	50	ms
Power supply cutt-off time	t _{OFF}		Repeated power-on reset	1		ms

Fig. 8. Power-on reset

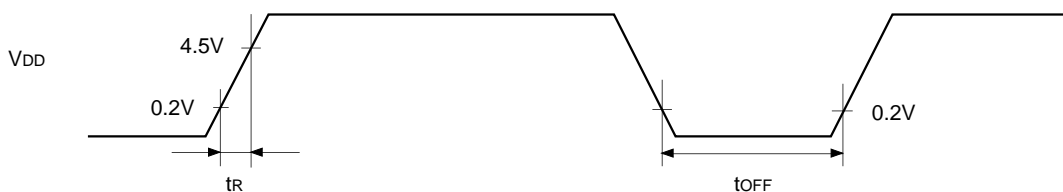

Take care when turning the power on.

(6) I²C bus timing

(T_a = -10 to +75°C, V_{DD} = 4.5 to 5.5V, V_{SS} = 0V reference)

Item	Symbol	Pin	Condition	Min.	Max.	Unit
SCL clock frequency	f _{SCL}	SCL		0	100	kHz
Bus-free time before starting transfer	t _{BUF}	SDA, SCL		4.7		μs
Hold time for starting transfer	t _{HD; STA}	SDA, SCL		4.0		μs
Clock Low level width	t _{LOW}	SCL		4.7		μs
Clock High level width	t _{HIGH}	SCL		4.0		μs
Setup time for repeated transfers	t _{SU; STA}	SDA, SCL		4.7		μs
Data hold time	t _{HD; DAT}	SDA, SCL		0*1		μs
Data setup time	t _{SU; DAT}	SDA, SCL		250		ns
SDA, SCL rise time	t _R	SDA, SCL			1	μs
SDA, SCL fall time	t _F	SDA, SCL			300	ns
Setup time for transfer completion	t _{SU; STO}	SDA, SCL		4.7		μs

*1 The data hold time should be 300ns or more because the SCL rise time (300ns Max.) is not included in it.

Fig. 9. I²C bus transfer timing

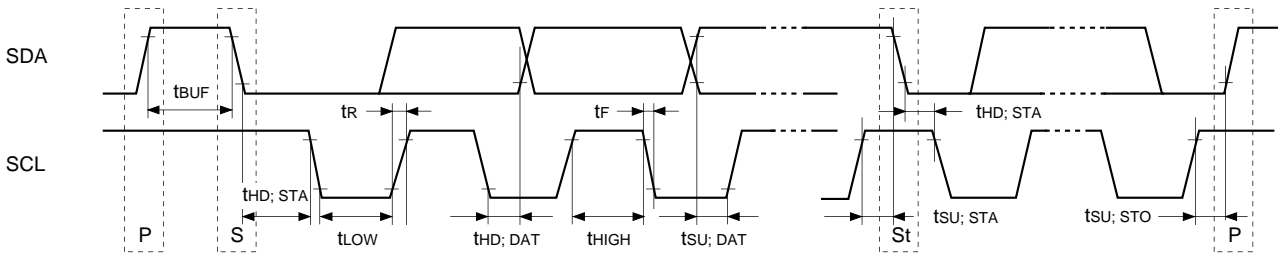
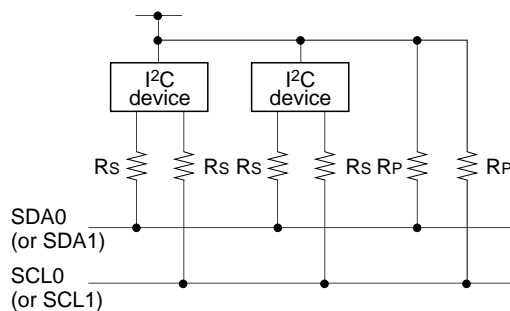

Fig. 10. I²C device recommended circuit



- A pull-up resistor must be connected to SDA0 (or SDA1) and SCL0 (or SCL1).
- The SDA0 (or SDA1) and SCL0 (or SCL1) series resistance (R_s = 300Ω or less) can be used to reduce spike noise caused by CRT flashover.

(7) OSD timing

(Ta = -10 to +75°C, VDD = 4.5 to 5.5V, Vss = 0V reference)

Item	Symbol	Pin	Condiiton	Min.	Max.	Unit
OSD clock frequency	fOSC	EXLC XLC	Fig. 12	4	16.5	MHz
HSYNC pulse width	tHWD	HSYNC	Fig. 11	1.2		µs
HSYNC after-write rise and fall times	tHCG	HSYNC	Fig. 11		200	ns
VSYNC before-write rise and fall times	tVCG	VSYNC	Fig. 11		1.0	µs

Fig. 11. OSD timing

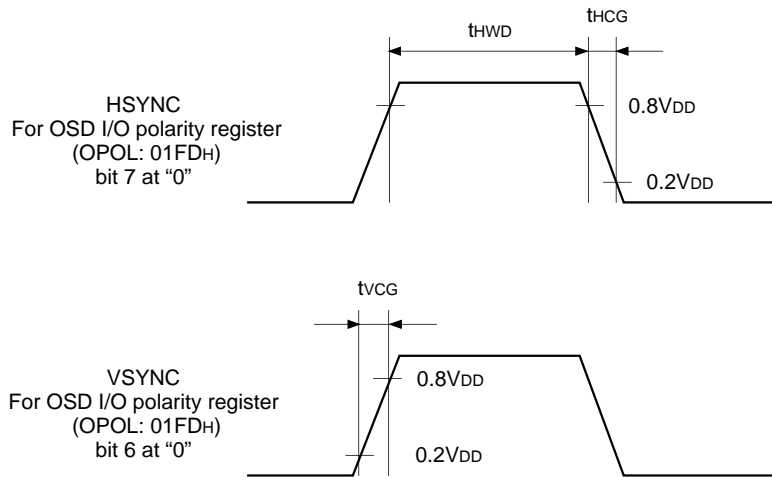
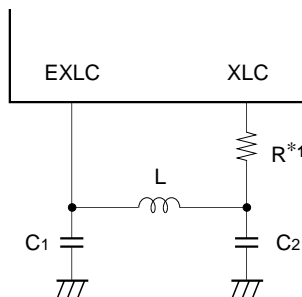

Fig. 12. LC oscillation circuit connection



*1 The XLC series resistor can reduce the occurrence of undersired radiation.

(8) Data slicer external circuit

($T_a = -10$ to $+75^\circ\text{C}$, $V_{DD} = 4.5$ to 5.5V , $V_{SS} = 0\text{V}$ reference)

Item	Symbol	Pin	Min.	Typ.	Max.	Unit	Remarks
VIN pin coupling capacitance	C_{VIN}	VIN		0.47		μF	The B characteristic or more of temperature characteristics is recommended.
Cap pin capacitance	Ccap	Cap		4700		pF	The B characteristic or more of temperature characteristics is recommended.
Rex pin pull-up resistance	Rrex	Rex		33		$\text{k}\Omega$	
Composite video signal input	Video In	VIN		2.0		Vp-p	

Fig. 13. Data slicer external recommended circuit

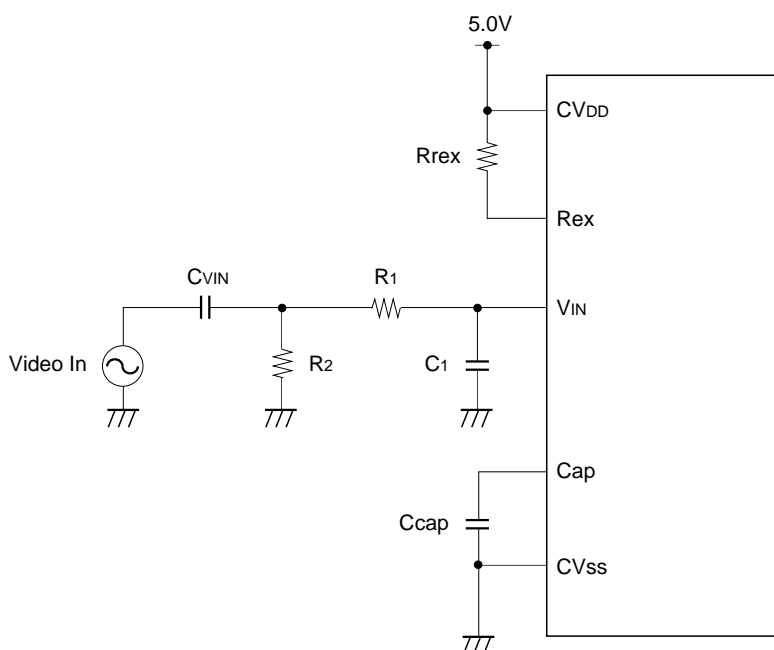

[Recommended Constant]

$R_1 = 100\Omega$ (error: 5%; allowable power dissipation: 1/8W or more)

$R_2 = 1\text{M}\Omega$ (error: 5%; allowable power dissipation: 1/8W or more)

$C_1 = 820\text{pF}$ (ceramic), the B characteristic or more of temperature characteristics is recommended.

Supplement

Fig. 14. SPC700 Series recommended oscillation circuit

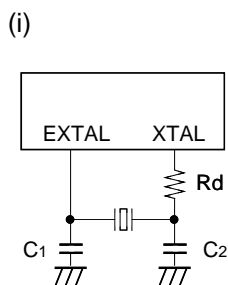

Manufacturer	Model	fc (MHz)	C1 (pF)	C2 (pF)	Rd (Ω)	Circuit example
RIVER ELETEC CO., LTD.	HC-49/U03	12.0	5	5	0*1	(i)
KINSEKI LTD.	HC-19/U (-S)	12.0	15	15	0*1	(i)

*1 The XTAL series resistor can reduce the effect of electrostatic discharge noise.

Products List

Option item	Mask	CXP856P40S-1- <input type="checkbox"/> <input type="checkbox"/> <input type="checkbox"/> CXP856P40Q-1- <input type="checkbox"/> <input type="checkbox"/> <input type="checkbox"/>
Package	64-pin plastic SDIP/QFP	64-pin plastic SDIP/QFP
Program ROM capacity	32/40K bytes	PROM 40K bytes
Reset-pin pull-up resistor	Existent/Non-existent	Existent
Power-on reset circuit	Existent/Non-existent	Existent
Font data	User specified	User specified (PROM)*2

*2 The font data for the one-time PROM version can be written in the same way as for the program.

Fig. 15. Characteristics curves

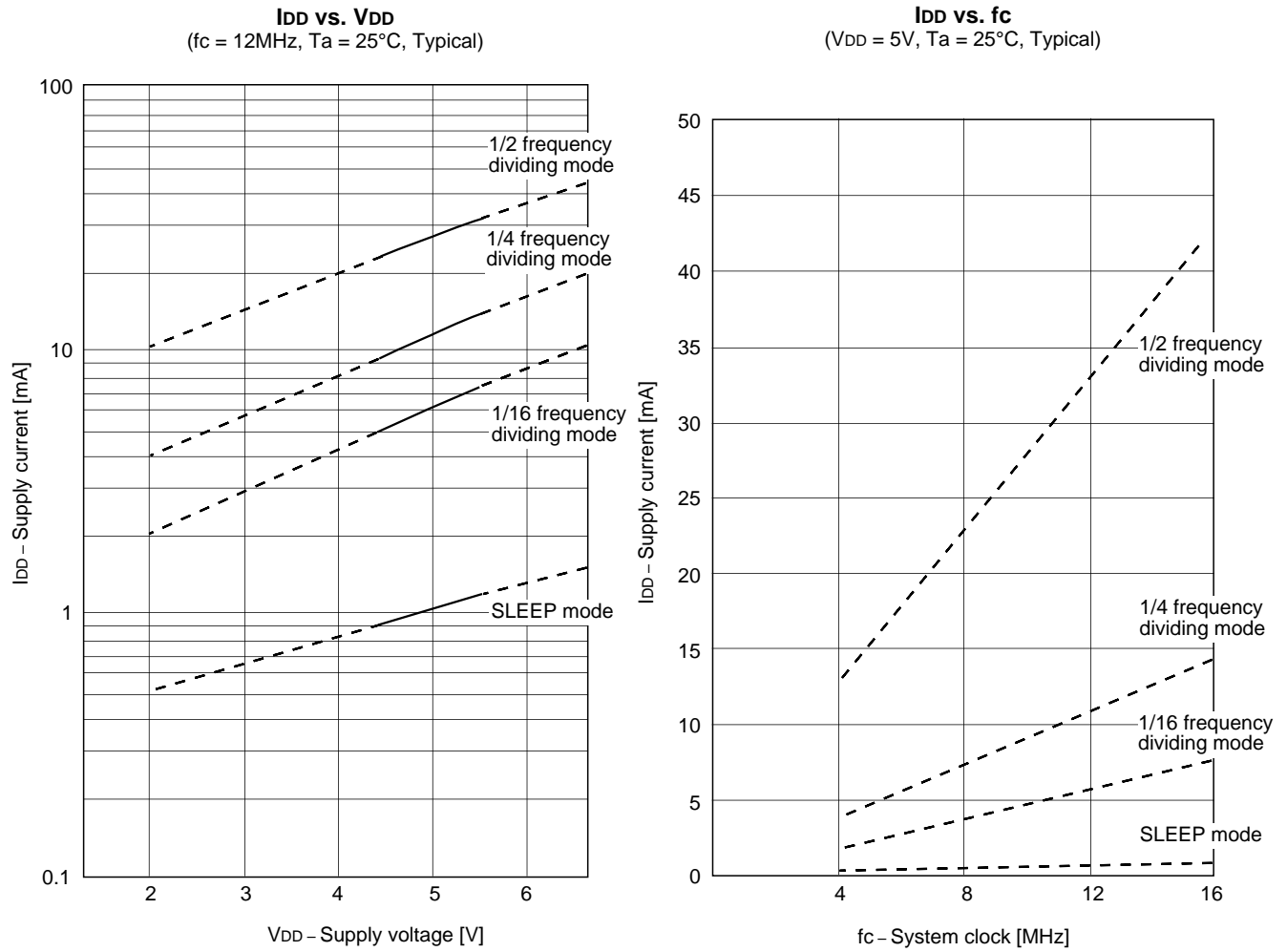

Parameter curve for OSD oscillation L vs. C
(Theoretically calculated value)

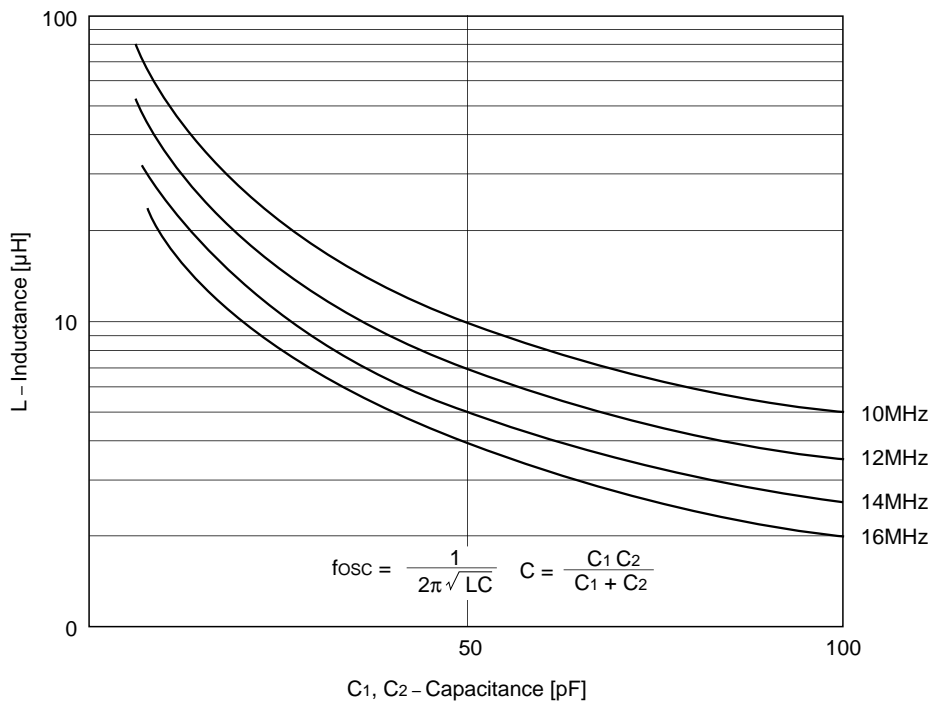



LittleDiode supplies new, hard to find or obsolete electronic components and semiconductors all over the world.

With over two million different components listed you are sure to find the part you need.

Feel free to visit us today at our online store:

LittleDiode.com

Looking forward to providing you with the best possible service.