

CXP85300A

Pin Assignment: Piggyback mode 1

(Top View) 64 pin PSDIP Package

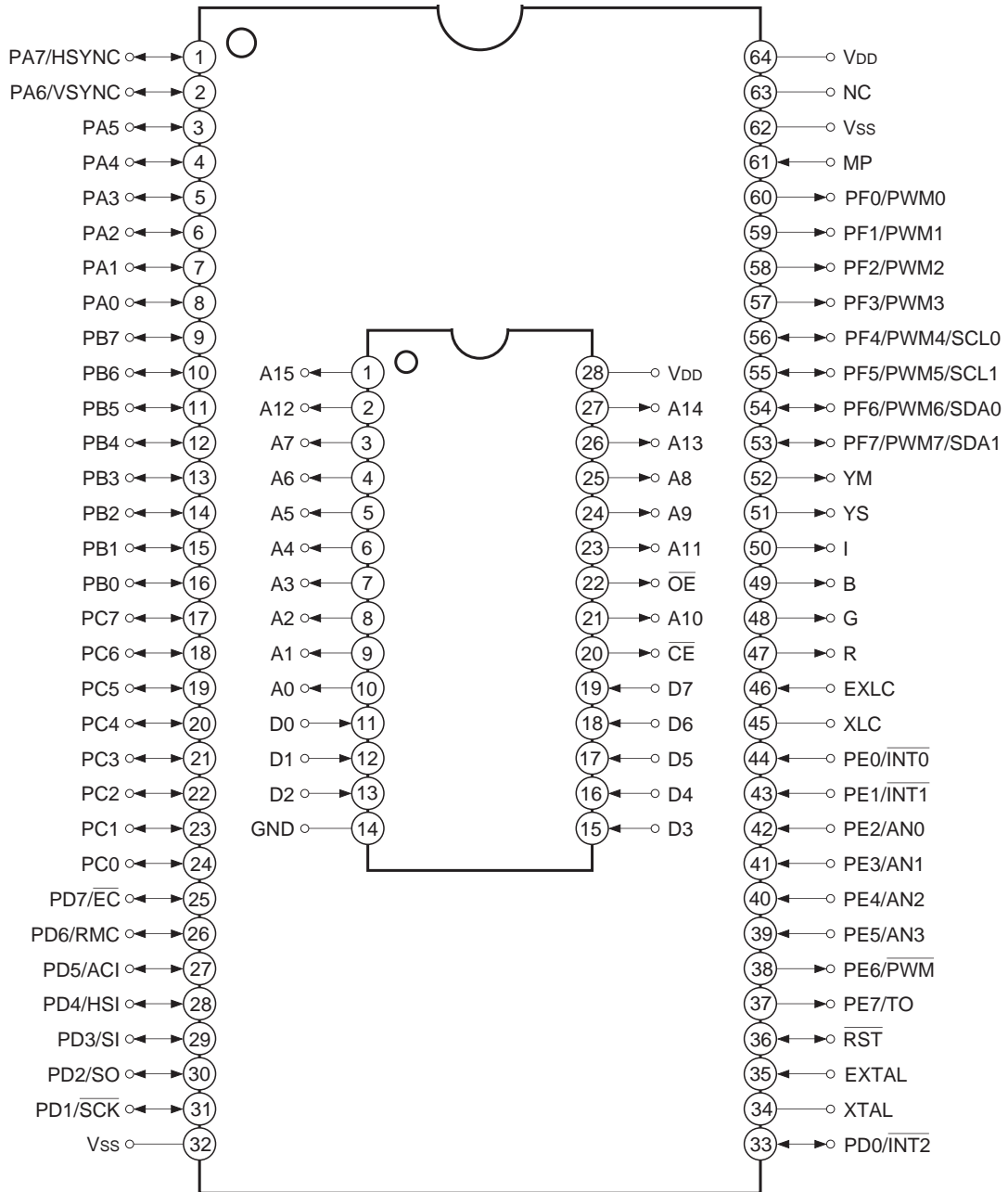

- Note)**
1. NC (Pin 63) is always connected to VDD.
 2. Vss (Pins 32 and 62) are always connected to GND.
 3. MP (Pin 61) is always connected to GND.

CXP85300A

Pin Assignment: Piggyback mode 2

(Top View) 64 pin PQFP Package

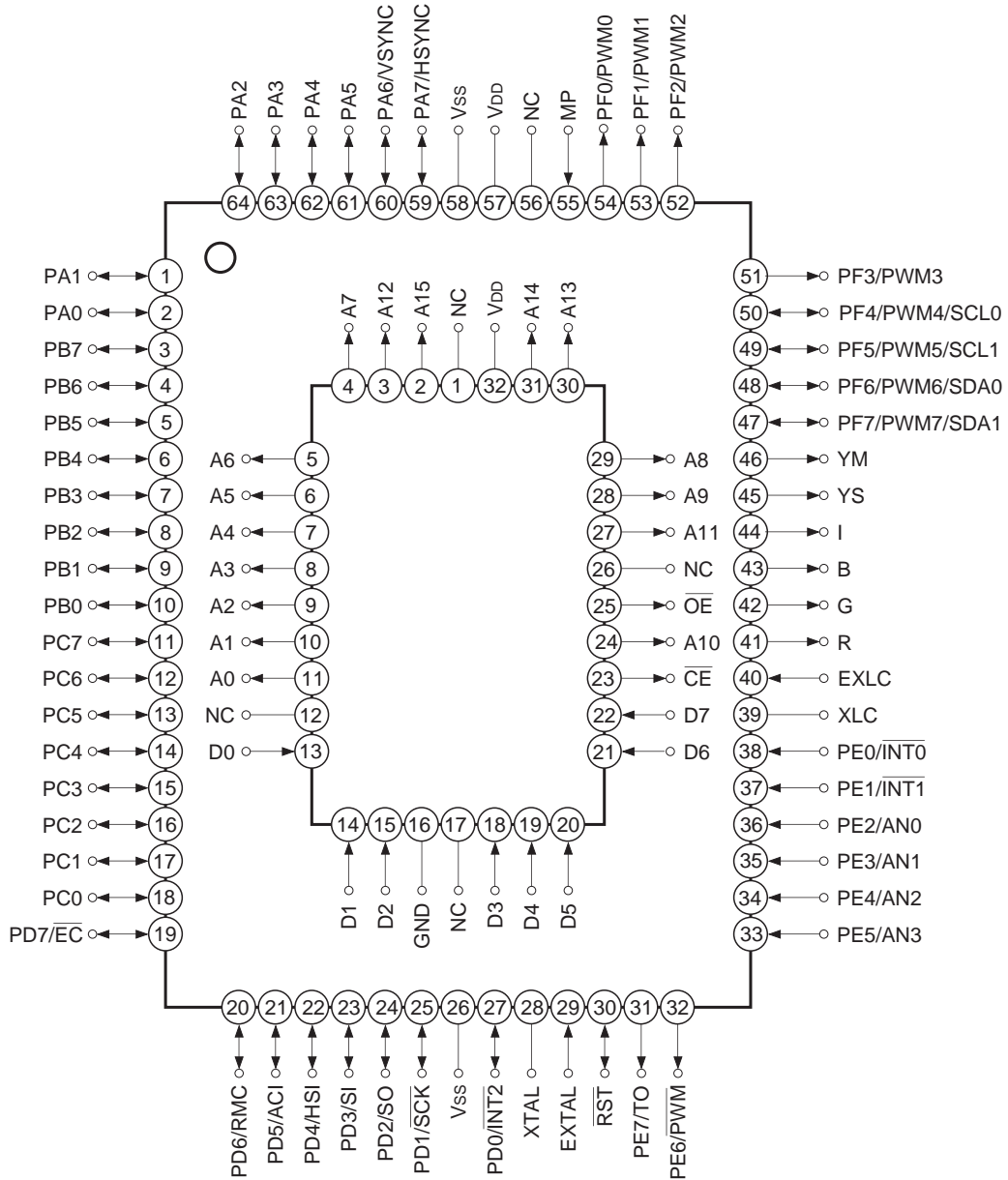

- Note)**
1. NC (Pin 56) is always connected to VDD.
 2. Vss (Pins 26 and 58) are always connected to GND.
 3. MP (Pin 55) is always connected to GND.

CXP85300A

Pin Assignment: Evaluator Mode 1

(Top View) 64 pin PSDIP Package

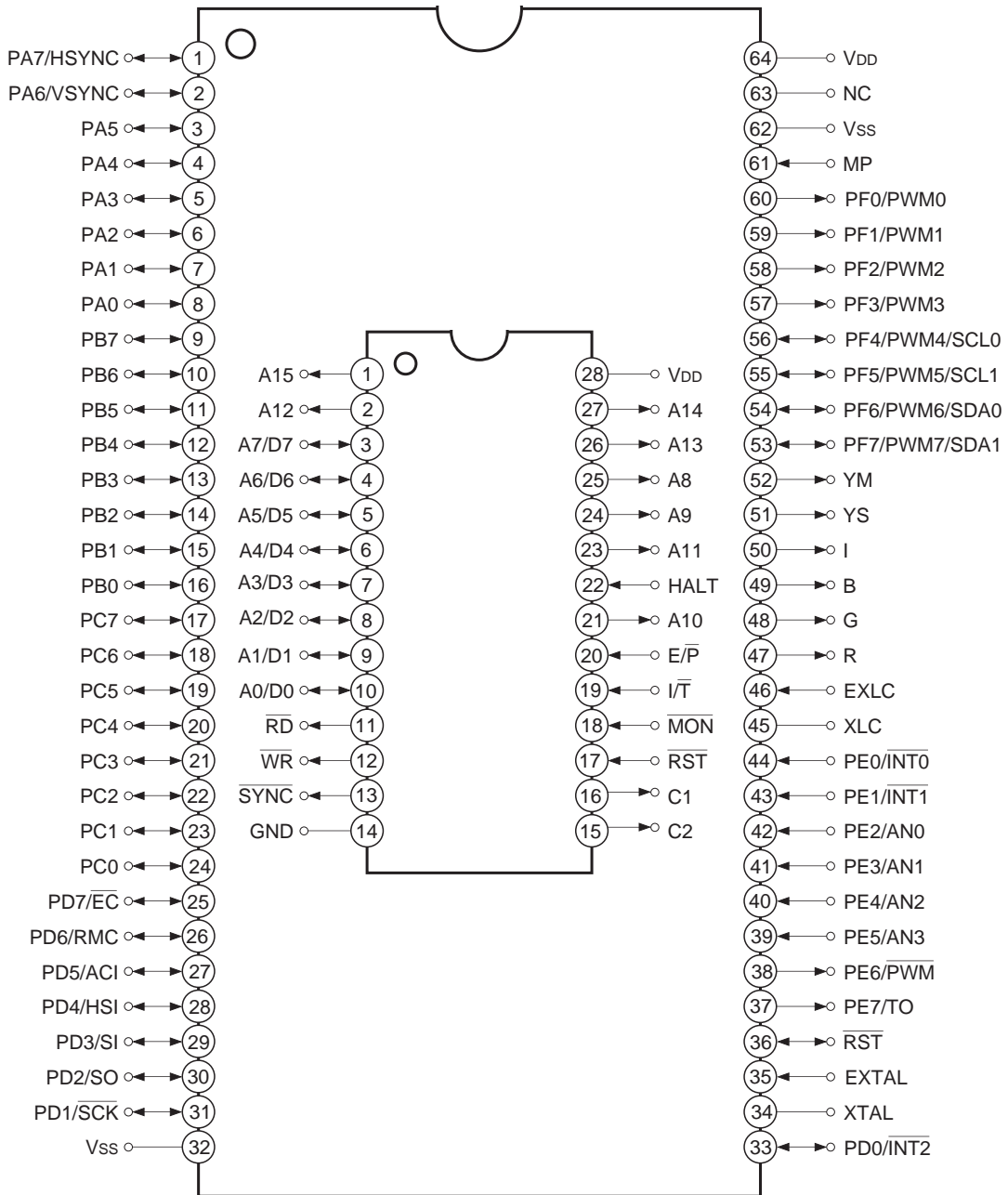

- Note)**
1. NC (Pin 63) is always connected to VDD.
 2. Vss (Pins 32 and 62) are always connected to GND.
 3. MP (Pin 61) is always connected to GND.

CXP85300A

Pin Assignment: Evaluator Mode 2

(Top View) 64 pin PQFP Package

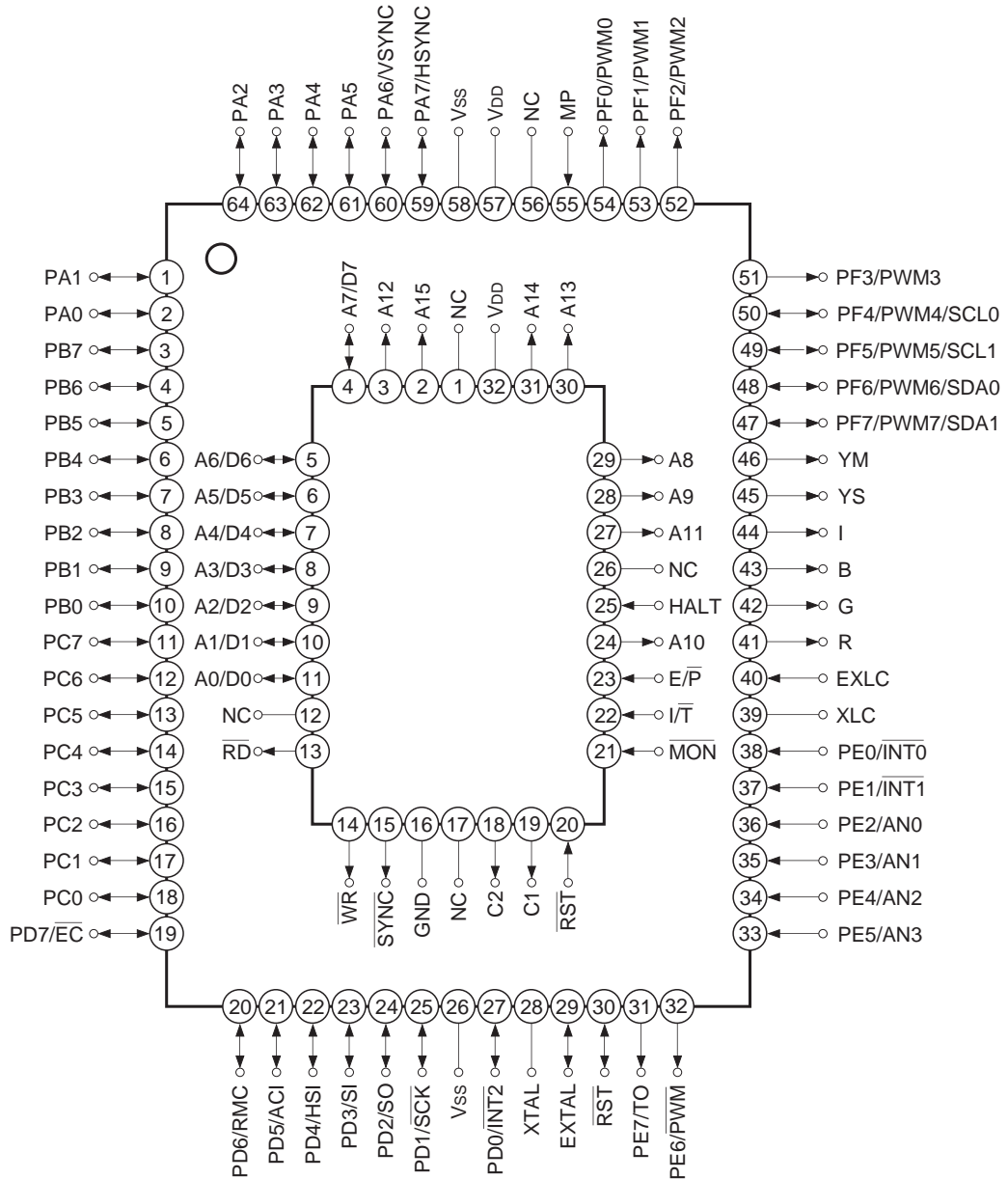

- Note)**
1. NC (Pin 56) is always connected to VDD.
 2. Vss (Pins 26 and 58) are always connected to GND.
 3. MP (Pin 55) is always connected to GND.

CXP85390A

Pin Assignment: Piggyback Mode

(Top View) 64 pin PSDIP Package

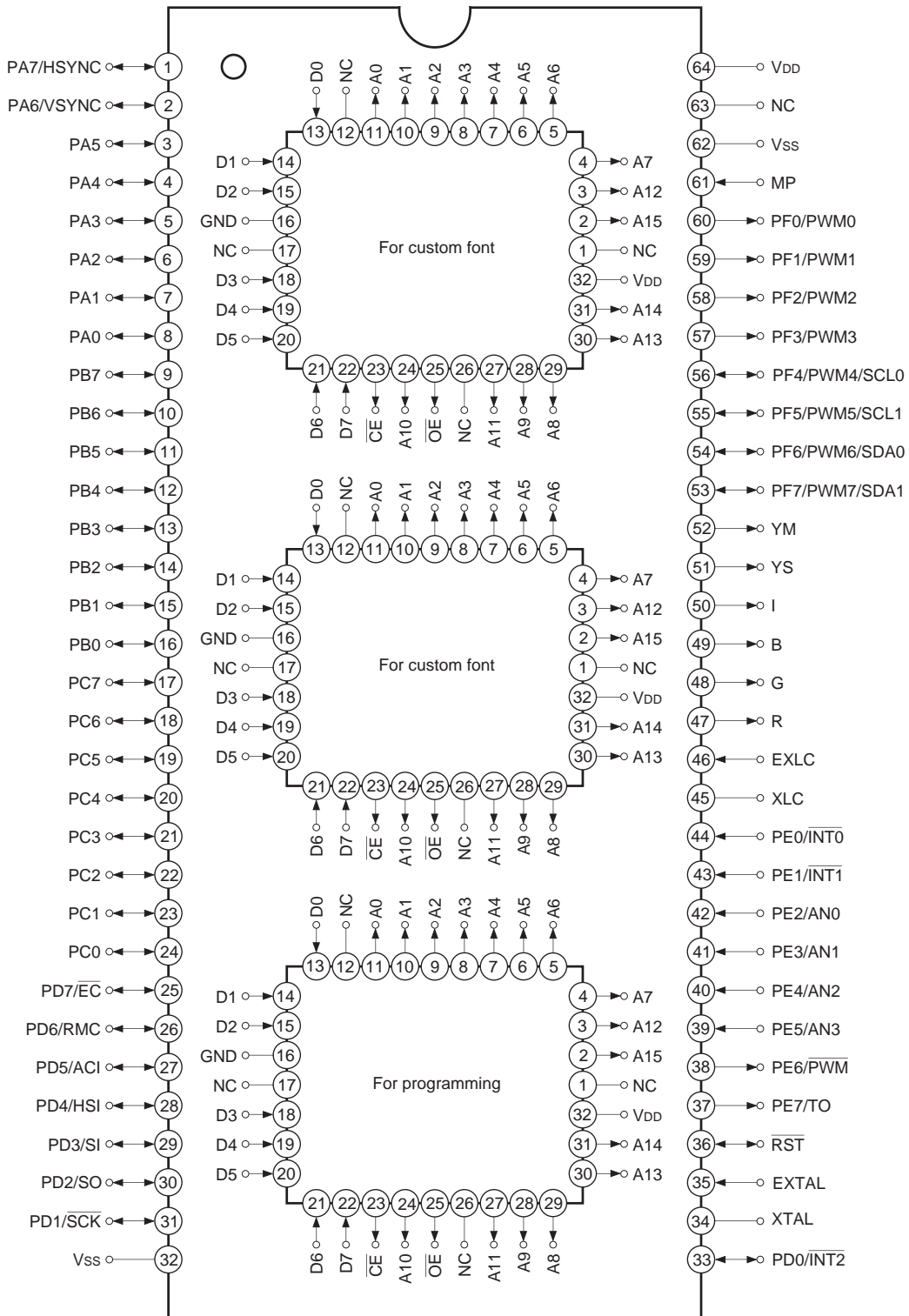

- Note)**
1. NC (Pin 63) is always connected to V_{DD}.
 2. V_{ss} (Pins 32 and 62) are always connected to GND.
 3. MP (Pin 61) is always connected to GND.

CXP85390A

Pin Assignment: Evaluator Mode

(Top View) 64 pin PSDIP Package

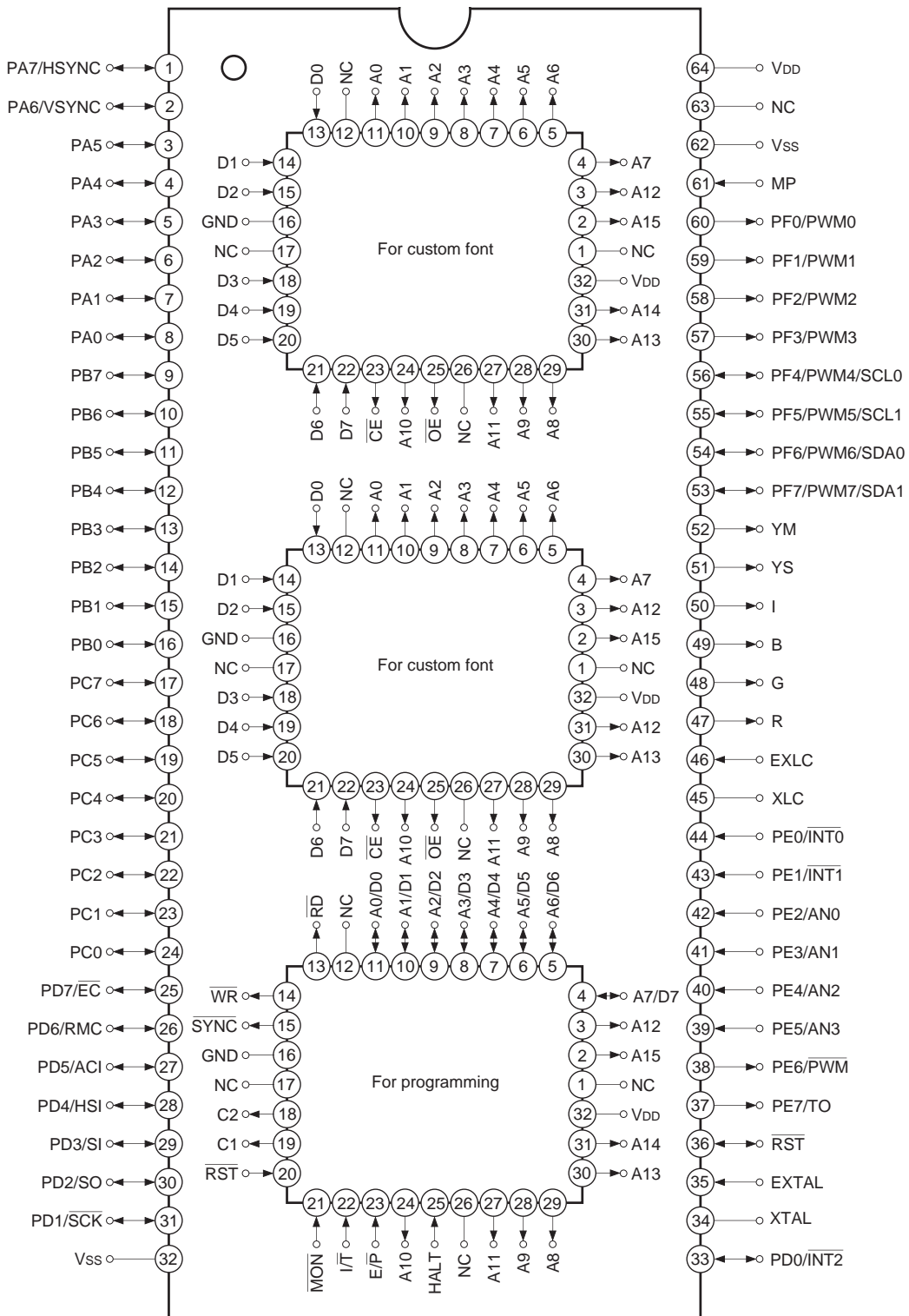

- Note)**
1. NC (Pin 63) is always connected to V_{DD}.
 2. V_{SS} (Pins 32 and 62) are always connected to GND.
 3. MP (Pin 61) is always connected to GND.

EPROM Read Timing

($T_a = -20$ to $+75^\circ\text{C}$, $V_{DD} = 4.5$ to 5.5V , $V_{SS} = 0\text{V}$)

| Item | Symbol | Pin | Min. | Max. | Unit |
|---------------------------------|-----------|-----------------------|------|-------|------|
| Address → data input delay time | t_{ACC} | A0 to A15 D0 to D7 | | 150*1 | ns |
| | | | | 250*2 | |
| Address → data hold time | t_{IH} | A0 to A15 D0 to D7 | 0 | | ns |

*1 Oscillator clock 8MHz version

*2 Oscillator clock 4MHz version

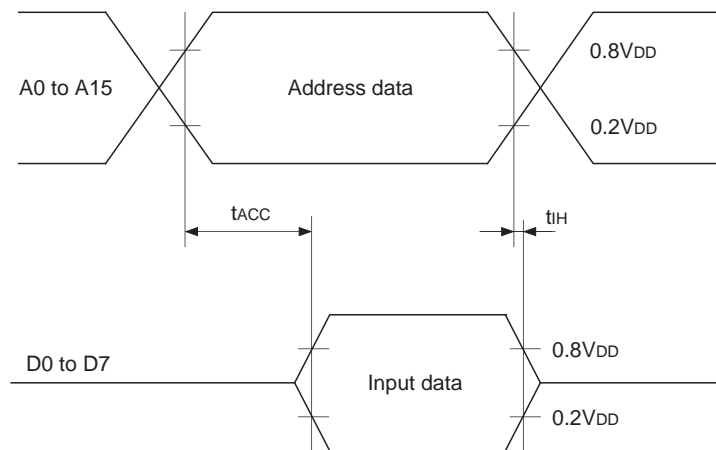

Product List

| Optional item | Product | | | | | | |
|----------------------------|-------------------------|-----------|-----------|----------------------------------|----------------------------------|----------------------|----------------|
| | Mask | | | Piggyback/evaluator | | | |
| | CXP85324A | CXP85332A | CXP85340A | CXP85300A-U02S CXP85300A-U02Q | CXP85300A-U03S CXP85300A-U03Q | CXP85390A-U02S | CXP85390A-U03S |
| Package | 64 pin plastic SDIP/QFP | | | 64 pin ceramic PSDIP/PQFP | | 64 pin ceramic PSDIP | |
| Oscillator clock | 4MHz/8MHz | | | 4MHz | 8MHz | 4MHz | 8MHz |
| ROM capacity | 24K bytes | 32K bytes | 40K bytes | EPROM 40K bytes | | | |
| Reset pin pull-up resistor | Existent/Non existent | | | Existent | | | |
| Power-on reset circuit | Existent/Non existent | | | Existent | | | |
| Font data | User data | | | Fixed | | EPROM 16K bytes | |

CXP85300A

Piggyback mode/evaluator mode switching process is as follows.

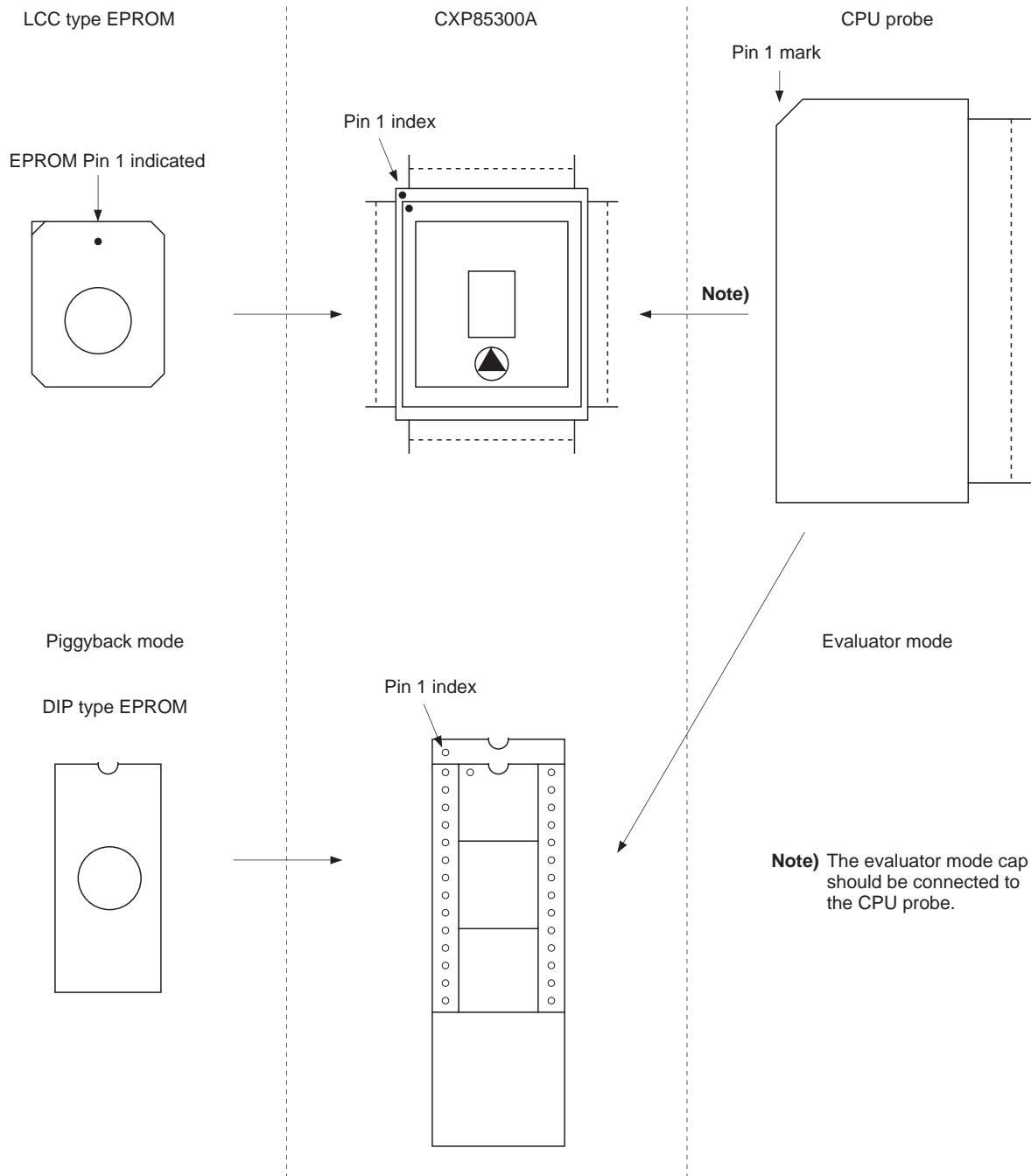

CXP85390A

Piggyback mode/evaluator mode switching process is as follows.

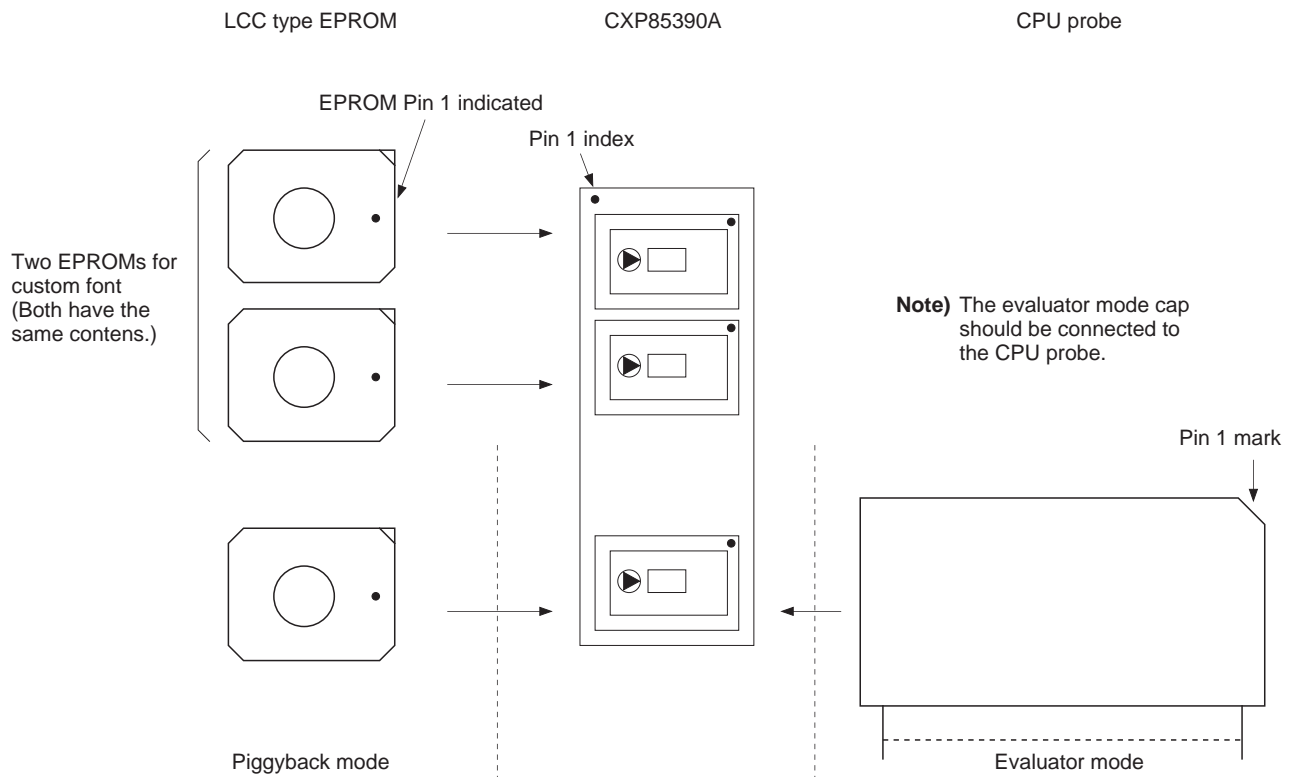

Package Outline

Unit: mm

64PIN PSDIP (CERAMIC) 750mil

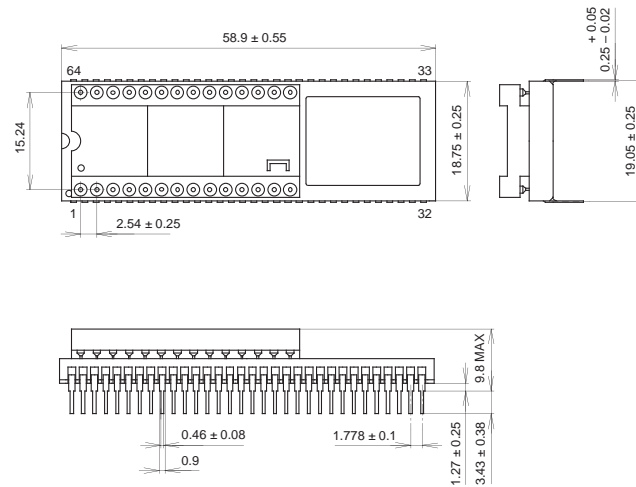

PACKAGE STRUCTURE

| | |
|------------|------------------|
| SONY CODE | PSDIP-64C-01 |
| EIAJ CODE | ADIP064-C-0750-A |
| JEDEC CODE | |

| | |
|------------------|--------------|
| PACKAGE MATERIAL | CERAMIC |
| LEAD TREATMENT | GOLD PLATING |
| LEAD MATERIAL | 42 ALLOY |
| PACKAGE WEIGHT | 16.0g |

64PIN PQFP (CERAMIC)

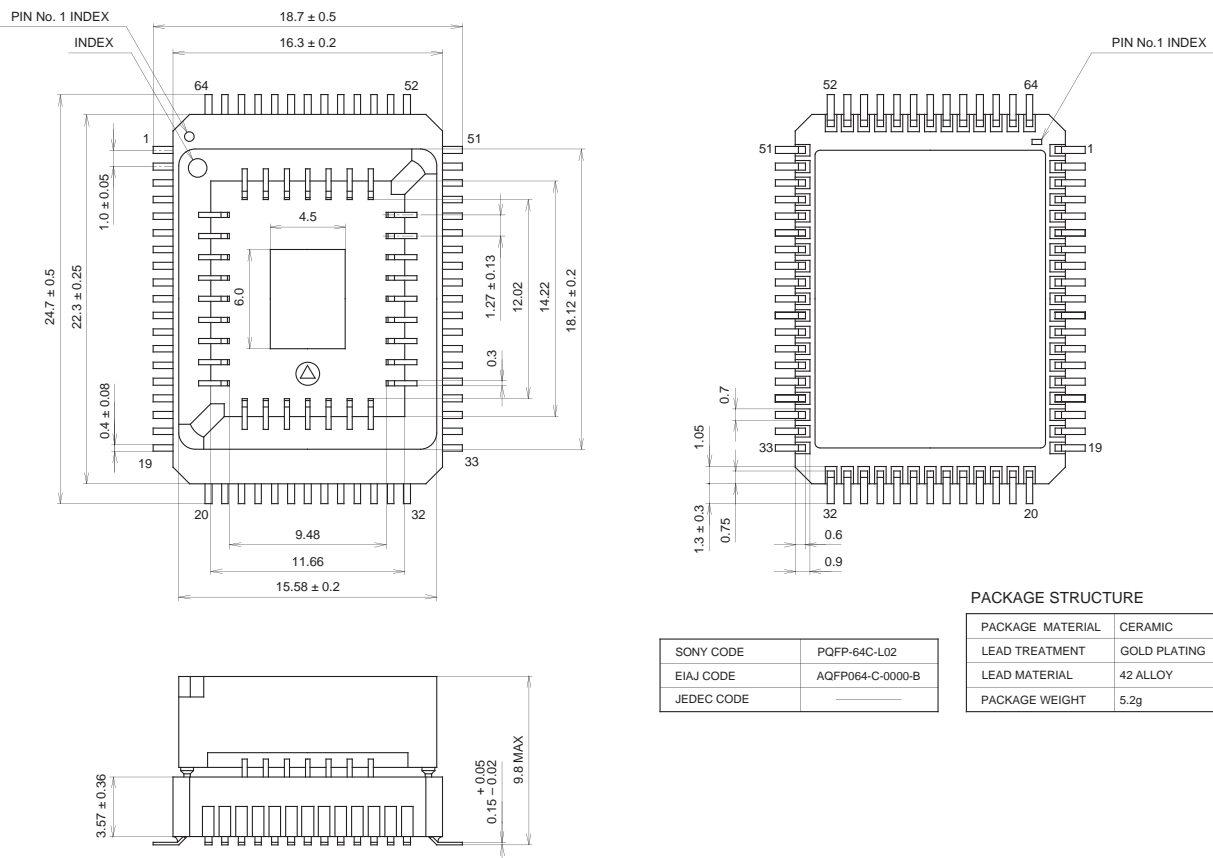

PACKAGE STRUCTURE

| | |
|------------|------------------|
| SONY CODE | PQFP-64C-L02 |
| EIAJ CODE | AQFP064-C-0000-B |
| JEDEC CODE | |

| | |
|------------------|--------------|
| PACKAGE MATERIAL | CERAMIC |
| LEAD TREATMENT | GOLD PLATING |
| LEAD MATERIAL | 42 ALLOY |
| PACKAGE WEIGHT | 5.2g |



LittleDiode supplies new, hard to find or obsolete electronic components and semiconductors all over the world.

With over two million different components listed you are sure to find the part you need.

Feel free to visit us today at our online store:

LittleDiode.com

Looking forward to providing you with the best possible service.