

## CMOS 8-bit Single Chip Microcomputer

### Description

The CXP84120/84124 is a CMOS 8-bit single chip micro-computer integrating on a single chip an A/D converter, serial interface, timer/counter, time base timer, capture timer/counter, remote control reception circuit and other servo systems besides the basic configurations of 8-bit CPU, ROM, RAM, and I/O port.

The CXP84120/84124 also provides a power-on reset function and a sleep/stop function that enables lower power consumption.

80 pin QFP (Plastic)

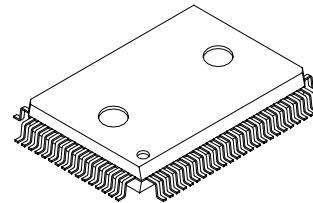

### Features

- Wide-range instruction system (213 instructions) to cover various types of data
  - 16-bit arithmetic/multiplication and division/Boolean bit operation instructions
- Minimum instruction cycle
  - 400ns at 10MHz operation
  - 122 $\mu$ s at 32kHz operation
- Incorporated ROM capacity
  - 20K bytes (CXP84120)
  - 24K bytes (CXP84124)
- Incorporated RAM capacity
  - 624 bytes
- Peripheral functions
  - A/D converter
    - 8 bits, 8 channels, successive approximation method  
(Conversion time of 32 $\mu$ s/10MHz)
  - Serial interface
    - SIO with 8-bit, 8-stage FIFO incorporated for data use  
(Auto transfer for 1 to 8 bytes), 1 channel
    - 8-bit standard SIO, 1 channel
  - Timer
    - 8-bit timer
    - 8-bit timer/counter
    - 19-bit time base timer
    - 16-bit capture timer/counter
    - 32kHz timer/counter
  - Remote control reception circuit
    - Incorporated noise elimination circuit
    - Incorporated 8-bit, 6-stage FIFO for measurement data
  - PWM output
    - 14 bits, 1 channel
- Interruption
  - 14 factors, 15 vectors, multi-interruption possible
- Standby mode
  - Sleep/stop
- Package
  - 80-pin plastic QFP
- Piggyback/evaluation chip
  - CXP84100 80-pin ceramic QFP

### Structure

Silicon gate CMOS IC

Sony reserves the right to change products and specifications without prior notice. This information does not convey any license by any implication or otherwise under any patents or other right. Application circuits shown, if any, are typical examples illustrating the operation of the devices. Sony cannot assume responsibility for any problems arising out of the use of these circuits.

Block Diagram

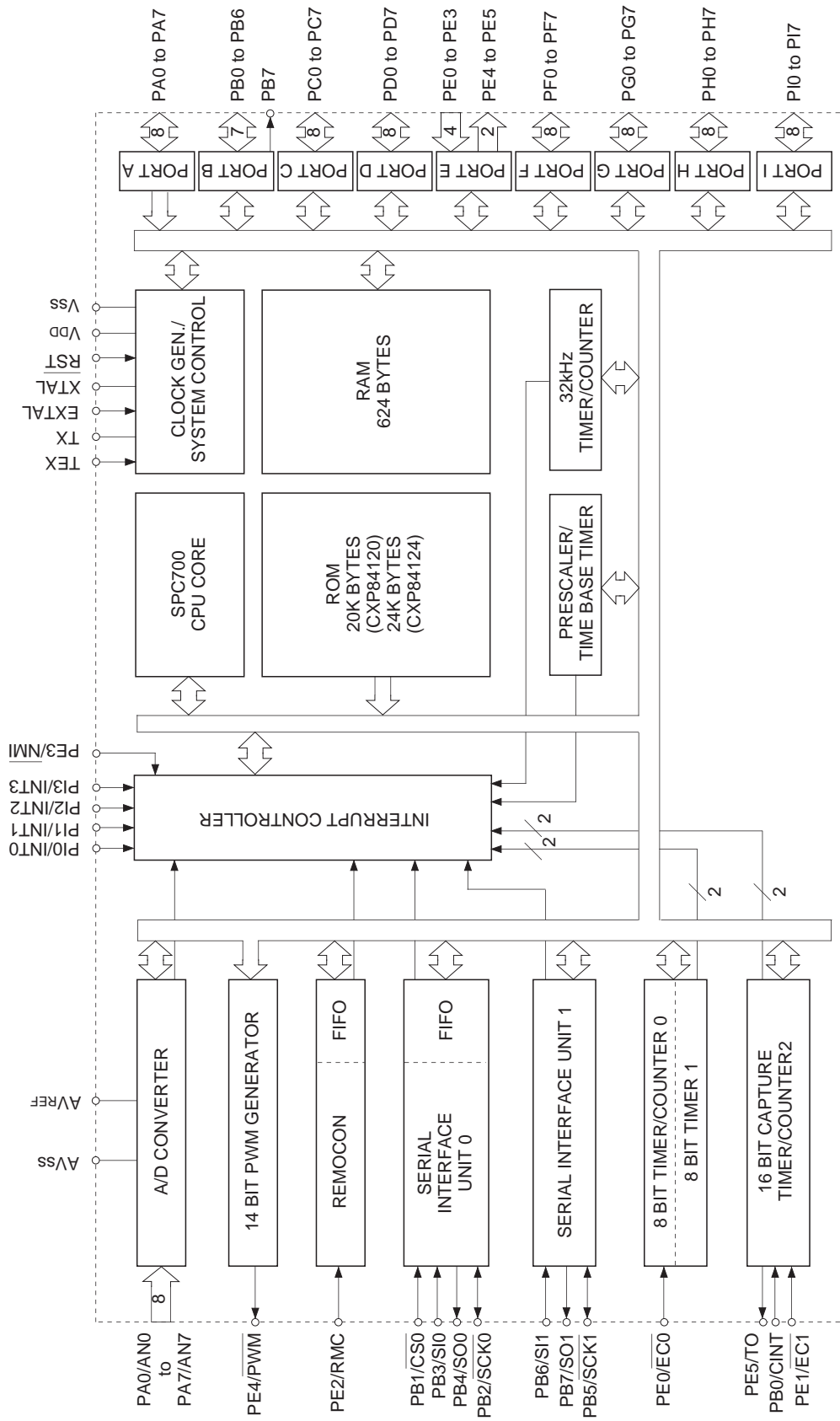

Pin Assignment (Top View)

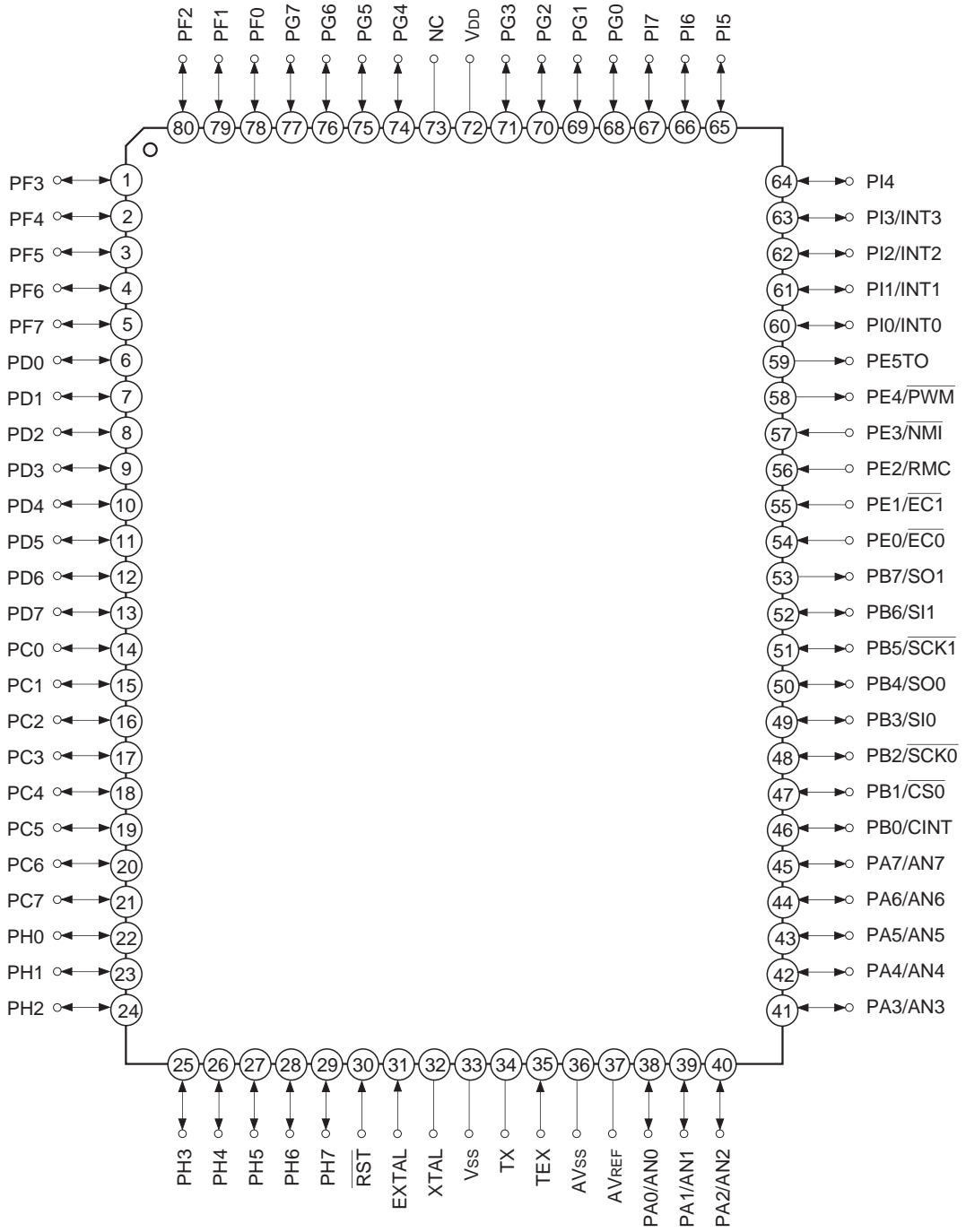

**Note)** NC (Pin 73) must be connected to V<sub>DD</sub>.

Pin Description

Symbol	I/O	Description	
PA0/AN0 to PA7/AN7	I/O/Analog input	(Port A) 8-bit I/O port. I/O can be set in a unit of single bit. Incorporation of the pull-up resistance can be set through the software in a unit of 4 bits. (8 pins)	Analog inputs to A/D converter. (8 pins)
PB0/CINT	I/O/Input	(Port B) 7-bit I/O port in which I/O can be set in a unit of single bit. Also, an uppermost bit (PB7) exclusively for output. Incorporation of pull-up resistor can be set through the software in a unit of 4 bits. (8 pins)	External capture input to 16-bit timer/counter.
PB1/ $\overline{\text{CS}}_0$	I/O/Input		Chip select input for serial interface (CH0).
PB2/ $\overline{\text{SCK}}_0$	I/O/I/O		Serial clock I/O (CH0).
PB3/SI0	I/O/Input		Serial data input (CH0).
PB4/SO0	I/O/Output		Serial data output (CH0).
PB5/ $\overline{\text{SCK}}_1$	I/O/I/O		Serial clock I/O (CH1).
PB6/SI1	I/O/Input		Serial data input (CH1).
PB7/SO1	Output/Output		Serial data output (CH1).
PC0 to PC7	I/O	(Port C) 8-bit I/O port. I/O can be set in a unit of single bit. Capable of driving 12mA sink current. Incorporation of pull-up resistor can be set through the software in a unit of 4 bits. (8 pins)	
PD0 to PD7	I/O	(Port D) 8-bit I/O port. I/O can be set in a unit of single bits. Incorporation of pull-up resistor can be set through the software in a unit of 4 bits. (8 pins)	
PE0/ $\overline{\text{EC}}_0$	Input/Input	(Port E) 6-bit port. Lower 4 bits are for inputs; upper 2 bits are for outputs. (6 pins)	External event inputs for timer/counter. (2 pins)
PE1/ $\overline{\text{EC}}_1$	Input/Input		
PE2/RMC	Input/Input		Remote control reception circuit input.
PE3/ $\overline{\text{NMI}}$	Input/Input		Non-maskable interruption request input.
PE4/ $\overline{\text{PWM}}$	Output/Output		14-bit PWM output.
PE5/TO/ADJ	Output/Output/ Output		Rectangular wave output for 16-bit timer/counter. Output for 32kHz oscillation frequency division.
PF0 to PF7	I/O	(Port F) 8-bit I/O port. I/O can be set in a unit of single bit. Incorporation of pull-up resistor can be set through the software in a unit of 4 bits. (8 pins)	

Symbol	I/O	Description	
PG0 to PG7	I/O	(Port G) 8-bit I/O port. I/O can be set in a unit of single bits. Incorporation of pull-up resistor can be set through the software in a unit of 4 bits. (8 pins)	
PH0 to PH7	I/O	(Port H) 8-bit I/O port. I/O can be set in a unit of single bits. Incorporation of pull-up resistor can be set through the software in a unit of 4 bits. (8 pins)	
PI0/INT0 to PI3/INT3	I/O/Input	(Port I) 8-bit I/O ports. I/O can be set in a unit of single bit. Incorporation of pull-up resistor can be set through the software in a unit of 4 bits. (8 pins)	External interruption request inputs.
PI4 to PI7	I/O		
EXTAL	Input	Crystal connectors for system clock oscillation. When the clock is supplied externally, input to EXTAL; opposite phase clock should be input to XTAL.	
XTAL	Output		
TEX	Input	Crystal connectors for 32kHz timer/counter clock generation circuit. Connect a 32kHz crystal oscillator between TEX and TX. For usage as event input, connect clock oscillation source to TEX, and open TX.	
TX	Output		
$\overline{\text{RST}}$	Input	Low-level active, system reset.	
NC		NC. Under normal operating conditions, connect to V <sub>DD</sub> .	
AV <sub>REF</sub>	Input	Reference voltage input for A/D converter.	
AV <sub>SS</sub>		A/D converter GND.	
V <sub>DD</sub>		Positive power supply.	
V <sub>SS</sub>		GND	

Input/Output Circuit Formats for Pins

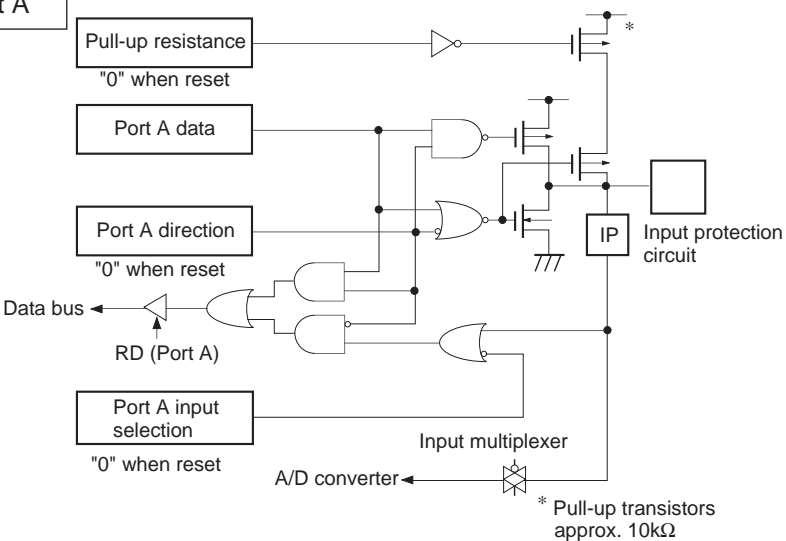
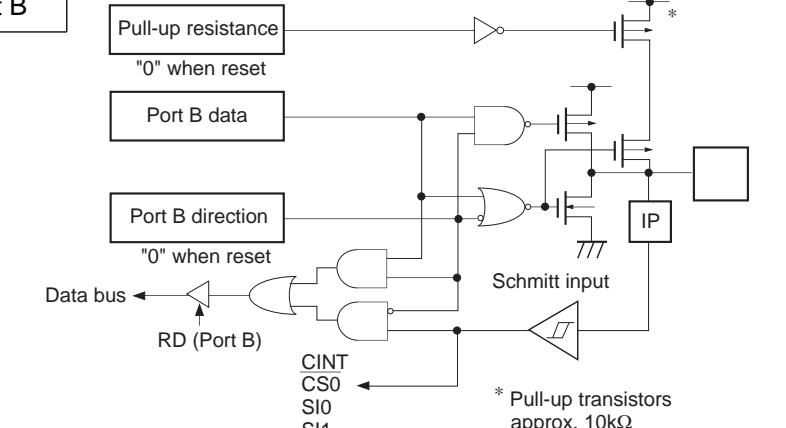
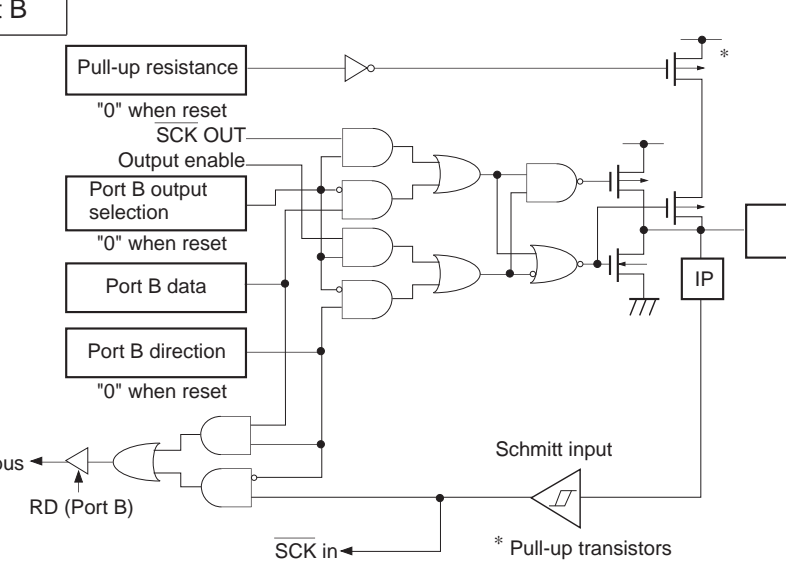
Pin	Circuit format	When reset
<p>PA0/AN0 to PA7/AN7</p> <p>8 pins</p>	<p>Port A</p>  <p>Pull-up resistance "0" when reset</p> <p>Port A data</p> <p>Port A direction "0" when reset</p> <p>Data bus ←</p> <p>RD (Port A)</p> <p>Port A input selection "0" when reset</p> <p>Input multiplexer</p> <p>A/D converter</p> <p>* Pull-up transistors approx. 10kΩ</p>	<p>Hi-Z</p>
<p>PB0/CINT PB1/CS0 PB3/SI0 PB6/SI1</p> <p>4 pins</p>	<p>Port B</p>  <p>Pull-up resistance "0" when reset</p> <p>Port B data</p> <p>Port B direction "0" when reset</p> <p>Data bus ←</p> <p>RD (Port B)</p> <p>CINT CS0 SI0 SI1</p> <p>Schmitt input</p> <p>* Pull-up transistors approx. 10kΩ</p>	<p>Hi-Z</p>
<p>PB2/SCK0 PB5/SCK1</p> <p>2 pins</p>	<p>Port B</p>  <p>Pull-up resistance "0" when reset</p> <p>SCK OUT</p> <p>Output enable</p> <p>Port B output selection "0" when reset</p> <p>Port B data</p> <p>Port B direction "0" when reset</p> <p>Data bus ←</p> <p>RD (Port B)</p> <p>SCK in</p> <p>Schmitt input</p> <p>* Pull-up transistors approx. 10kΩ</p>	<p>Hi-Z</p>

Pin	Circuit format	When reset
<p>PB4/SO0</p> <p>1 pin</p>	<p>Port B</p> <p>* Pull-up transistors approx. 10kΩ</p>	<p>Hi-Z</p>
<p>PB7/SO1</p> <p>1 pin</p>	<p>Port B</p> <p>* Pull-up transistors approx. 10kΩ</p>	<p>High level</p>
<p>PC0 to PC7</p> <p>8 pins</p>	<p>Port C</p> <p>*1 Large current drive of 12mA possible *2 Pull-up transistors approx. 10kΩ</p>	<p>Hi-Z</p>
<p>PE0/<math>\overline{\text{EC0}}</math> PE1/<math>\overline{\text{EC1}}</math> PE2/RMC PE3/<math>\overline{\text{NMI}}</math></p> <p>4 pins</p>	<p>Port E</p>	<p>Hi-Z</p>

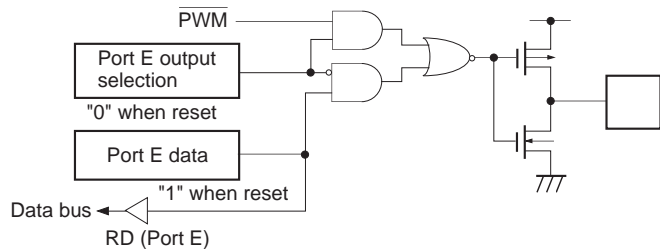
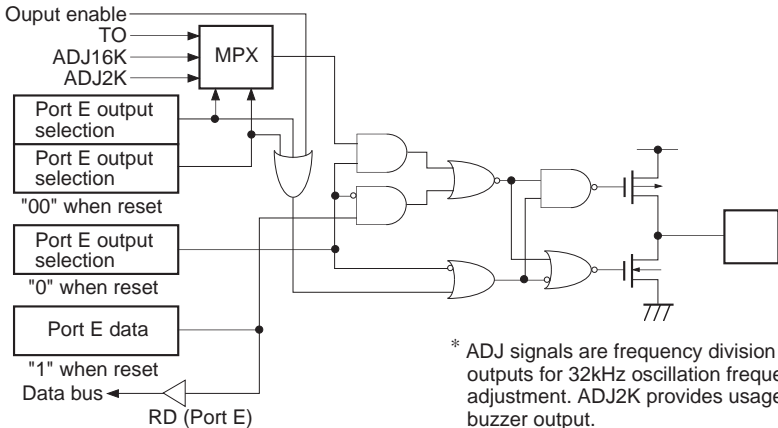
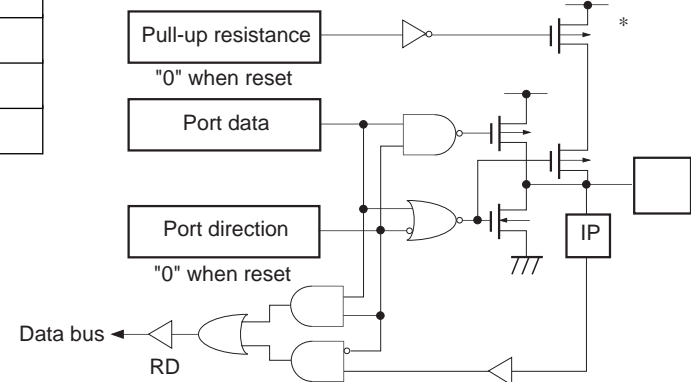
Pin	Circuit format	When reset
<p>PE4/PWM</p> <p>1 pin</p>	<p>Port E</p>  <p>"0" when reset</p> <p>"1" when reset</p> <p>Data bus ← RD (Port E)</p>	<p>High level</p>
<p>PE5/TO/ADJ</p> <p>1 pin</p>	<p>Port E</p>  <p>Output enable</p> <p>TO</p> <p>ADJ16K</p> <p>ADJ2K</p> <p>MPX</p> <p>Port E output selection</p> <p>Port E output selection</p> <p>"00" when reset</p> <p>Port E output selection</p> <p>"0" when reset</p> <p>Port E data</p> <p>"1" when reset</p> <p>Data bus ← RD (Port E)</p> <p>* ADJ signals are frequency division outputs for 32kHz oscillation frequency adjustment. ADJ2K provides usage as buzzer output.</p>	<p>High level</p>
<p>PD0 to PD7 PF0 to PF7 PG0 to PG7 PH0 to PH7 PI4 to PI7</p> <p>36 pins</p>	<p>Port D</p> <p>Port F</p> <p>Port G</p> <p>Port H</p> <p>Port I</p>  <p>Pull-up resistance</p> <p>"0" when reset</p> <p>Port data</p> <p>Port direction</p> <p>"0" when reset</p> <p>Data bus ← RD</p> <p>* Pull-up transistors approx. 10kΩ</p>	<p>Hi-Z</p>

Pin	Circuit format	When reset
<p>PI0/INT0 to PI3/INT3</p> <p>4 pins</p>	<p>Port I</p> <p>Pull-up resistance "0" when reset</p> <p>Port data</p> <p>Port direction "0" when reset</p> <p>Data bus</p> <p>RD</p> <p>INT0 INT1 INT2 INT3</p> <p>* Pull-up transistors approx. 10kΩ</p>	<p>Hi-Z</p>
<p>EXTAL XTAL</p> <p>2 pins</p>	<ul style="list-style-type: none"> <li>• Diagram shows circuit composition during oscillation.</li> <li>• Feedback resistor is removed during stop.</li> </ul>	<p>Oscillation</p>
<p>TEX TX</p> <p>2 pins</p>	<ul style="list-style-type: none"> <li>• Diagram shows circuit composition during oscillation.</li> <li>• When the operation of the oscillation circuit is stopped by the software, the feedback resistor is removed, and TEX and TX become "Low" level and "High" level respectively.</li> </ul>	<p>Oscillation</p>
<p><math>\overline{\text{RST}}</math></p> <p>1 pin</p>	<p>Pull-up resistor</p> <p>Mask option OP</p> <p>Schmitt input</p>	<p>Low level</p>

**Absolute Maximum Ratings**

(V<sub>SS</sub> = 0V reference)

Item	Symbol	Rating	Unit	Remarks
Supply voltage	V <sub>DD</sub>	-0.3 to +7.0	V	
	AV <sub>SS</sub>	-0.3 to +0.3	V	
Input voltage	V <sub>IN</sub>	-0.3 to +7.0*1	V	
Output voltage	V <sub>OUT</sub>	-0.3 to +7.0*1	V	
High level output current	I <sub>OH</sub>	-5	mA	Output per pin
High level total output current	∑I <sub>OH</sub>	-50	mA	Total for all output pins
Low level output current	I <sub>OL</sub>	15	mA	Value per pin, excluding large current outputs
	I <sub>OLC</sub>	20	mA	Value per pin*2 for large current outputs
Low level total output current	∑I <sub>OL</sub>	100	mA	Total for all output pins
Operating temperature	T <sub>opr</sub>	-20 to +75	°C	
Storage temperature	T <sub>stg</sub>	-55 to +150	°C	
Allowable power dissipation	P <sub>D</sub>	600	mW	

\*1 V<sub>IN</sub> and V<sub>OUT</sub> must not exceed V<sub>DD</sub> + 0.3V.

\*2 The large current drive transistor is the N-ch transistor of Port C (PC).

**Note)** Usage exceeding absolute maximum ratings may permanently impair the LSI. Normal operation should be conducted under the recommended operating conditions. Exceeding these conditions may adversely affect the reliability of the LSI.

**Recommended Operating Conditions**

(V<sub>SS</sub> = 0V reference)

Item	Symbol	Min.	Max.	Unit	Remarks
Supply voltage	V <sub>DD</sub>	4.5	5.5	V	High-speed mode guaranteed operation range*1
		3.5	5.5		Low-speed mode guaranteed operation range*1
		2.7	5.5		Guaranteed operation range with TEX clock
		2.5	5.5		Guaranteed data hold range during stop
High level input voltage	V <sub>IH</sub>	0.7V <sub>DD</sub>	V <sub>DD</sub>	V	*2
	V <sub>IHS</sub>	0.8V <sub>DD</sub>	V <sub>DD</sub>	V	Hysteresis input*3
	V <sub>IHEX</sub>	V <sub>DD</sub> - 0.4	V <sub>DD</sub> + 0.3	V	EXTAL*4
Low level input voltage	V <sub>IL</sub>	0	0.3V <sub>DD</sub>	V	*2
	V <sub>ILS</sub>	0	0.2V <sub>DD</sub>	V	Hysteresis input*3
	V <sub>ILEX</sub>	-0.3	0.4	V	EXTAL*4
Operating temperature	T <sub>opr</sub>	-20	+75	°C	

\*1 High-speed mode is 1/2 frequency division clock selection; low-speed mode is 1/16 frequency division clock selection.

\*2 Value for each pin of normal input ports (PA, PB3, PB4, PB6, PC, PD, PF to PH, PI4 to PI7).

\*3 Value of the following pins: RST, CINT, CS0, SCK0, SCK1, EC0, EC1, RMC, NMI, INT0, INT1, INT2, INT3.

\*4 Specifies only during external clock input.

**Electrical Characteristics**

**DC Characteristics**

(Ta = -20 to +75°C, Vss = 0V reference)

Item	Symbol	Pins	Conditions	Min.	Typ.	Max.	Unit	
High level output voltage	VOH	PA to PD, PE4, PE5, PF to PI	VDD = 4.5V, IOH = -0.5mA	4.0			V	
			VDD = 4.5V, IOH = -1.2mA	3.5			V	
Low level output voltage	VOL		VDD = 4.5V, IOL = 1.8mA			0.4	V	
			VDD = 4.5V, IOL = 3.6mA			0.6	V	
Input current	IIHE	EXTAL	VDD = 5.5V, VIH = 5.5V	0.5		40	μA	
			VDD = 5.5V, VIL = 0.4V	-0.5		-40	μA	
	IIHT	TEX	VDD = 5.5V, VIH = 5.5V	0.1		10	μA	
				-0.1		-10	μA	
	IILR	RST*1	VDD = 5.5V, VIL = 0.4V	-1.5		-400	μA	
	IIL	PA to PD*2, PF to PI*2					-2.0	mA
VDD = 4.5V, VIL = 4.0V			-10			μA		
I/O leakage current	IIZ	PE0 to PE3, RST*1	VDD = 5.5V, VI = 0, 5.5V			±10	μA	
Power supply current*3	IDD1	VDD	High-speed mode operation (1/2 frequency division clock)		18	40	mA	
			VDD = 5.5V, 10MHz crystal oscillation (C1 = C2 = 15pF)					
	IDD2		VDD = 3V, 32kHz crystal oscillation (C1 = C2 = 47pF)		35	100	μA	
	IDDS1		Sleep mode			1.1	8	mA
			VDD = 5.5V, 10MHz crystal oscillation (C1 = C2 = 15pF)					
	IDDS2		VDD = 3V, 32kHz crystal oscillation (C1 = C2 = 47pF)		9	30	μA	
IDDS3	Stop mode				10	μA		
	VDD = 5.5V, termination of 10MHz and 32kHz crystal oscillation							
Input capacity	CIN	Pins other than PB7, PE4, PE5, AVREF, AVSS, VDD, VSS	Clock 1MHz 0V for all pins excluding measured pins		10	20	pF	

\*1 RST specifies the input current when pull-up resistance has been selected; leakage current when no resistance has been selected.

\*2 Pins PA to PD, and PF to PI specify the input current when pull-up resistance has been selected; leakage current when no resistance has been selected. (Excludes output PB7)

\*3 When all pins are open.

AC Characteristics

(1) Clock timing

( $T_a = -20$  to  $+75^\circ\text{C}$ ,  $V_{DD} = 4.5$  to  $5.5\text{V}$ ,  $V_{SS} = 0\text{V}$  reference)

Item	Symbol	Pins	Conditions	Min.	Typ.	Max.	Unit
System clock frequency	$f_c$	XTAL EXTAL	Fig. 1, Fig. 2	1		10	MHz
System clock input pulse width	$t_{XL}$ , $t_{XH}$	EXTAL	Fig. 1, Fig. 2 External clock drive	37.5			ns
System clock input rise time, fall time	$t_{CR}$ , $t_{CF}$	EXTAL	Fig. 1, Fig. 2 External clock drive			200	ns
Event count input clock pulse width	$t_{EH}$ , $t_{EL}$	$\overline{\text{EC0}}$ $\overline{\text{EC1}}$	Fig. 3	$t_{\text{sys}} + 50^{*1}$			ns
Event count input clock rise time, fall time	$t_{ER}$ , $t_{EF}$	$\overline{\text{EC0}}$ $\overline{\text{EC1}}$	Fig. 3			20	ms
System clock frequency	$f_c$	TEX TX	$V_{DD} = 2.7$ to $5.5\text{V}$ Fig. 2 (32kHz clock applied condition)		32.768		kHz
Event count input clock input pulse width	$t_{TL}$ , $t_{TH}$	TEX	Fig. 3	10			$\mu\text{s}$
Event count input clock rise time, fall time	$t_{TR}$ , $t_{TF}$	TEX	Fig. 3			20	ms

\*1  $t_{\text{sys}}$  indicates the three values below according to the upper two bits (CPU clock selection) of the clock control register (address: 00FEH).

$t_{\text{sys}} [\text{ns}] = 2000/f_c$  (upper two bits = "00"),  $4000/f_c$  (upper two bits = "01"),  $16000/f_c$  (upper two bits = "11")

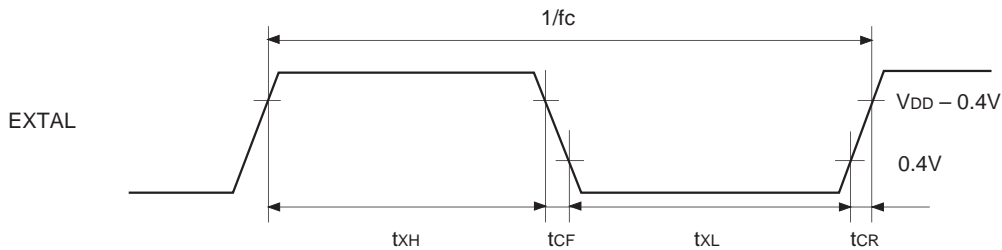

Fig. 1. Clock timing

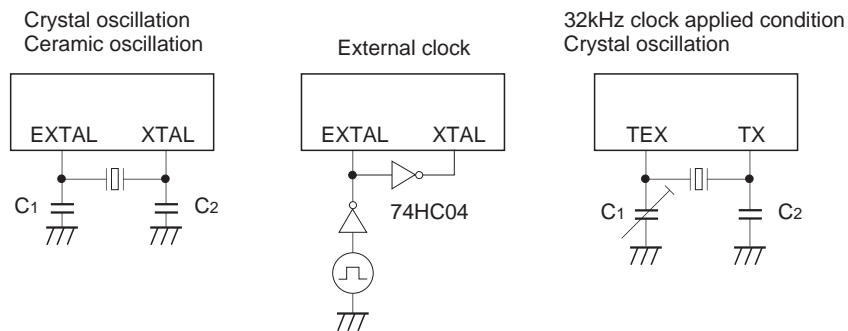

Fig. 2. Clock applied conditions

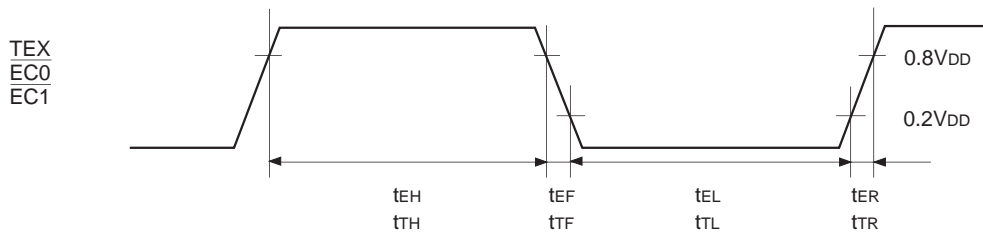

Fig. 3. Event count clock timing

(2) Serial transfer (CH0)

(Ta = -20 to +75°C, V<sub>DD</sub> = 4.5 to 5.5V, V<sub>SS</sub> = 0V reference)

Item	Symbol	Pin	Condition	Min.	Max.	Unit
$\overline{CS0} \downarrow \rightarrow \overline{SCK0}$ delay time	t <sub>dCSK</sub>	$\overline{SCK0}$	Chip select transfer mode ( $\overline{SCK0}$ = output mode)		t <sub>sys</sub> + 200	ns
$\overline{CS0} \uparrow \rightarrow \overline{SCK0}$ float delay time	t <sub>dCSKF</sub>	$\overline{SCK0}$	Chip select transfer mode ( $\overline{SCK0}$ = output mode)		t <sub>sys</sub> + 200	ns
$\overline{CS0} \downarrow \rightarrow SO0$ delay time	t <sub>dCSO</sub>	SO0	Chip select transfer mode		t <sub>sys</sub> + 200	ns
$\overline{CS0} \uparrow \rightarrow SO0$ float delay time	t <sub>dCSOF</sub>	SO0	Chip select transfer mode		t <sub>sys</sub> + 200	ns
$\overline{CS0}$ High level width	t <sub>WHCS</sub>	$\overline{CS0}$	Chip select transfer mode	t <sub>sys</sub> + 200		ns
$\overline{SCK0}$ cycle time	t <sub>kCY</sub>	$\overline{SCK0}$	Input mode	2t <sub>sys</sub> + 200		ns
			Output mode	16000/fc		ns
$\overline{SCK0}$ High, Low level width	t <sub>kH</sub> , t <sub>kL</sub>	$\overline{SCK0}$	Input mode	t <sub>sys</sub> + 100		ns
			Output mode	8000/fc - 50		ns
SI0 input setup time (for $\overline{SCK0} \uparrow$ )	t <sub>sIK</sub>	SI0	$\overline{SCK0}$ input mode	100		ns
			$\overline{SCK0}$ output mode	200		ns
SI0 input hold time (for $\overline{SCK0} \uparrow$ )	t <sub>kSI</sub>	SI0	$\overline{SCK0}$ input mode	t <sub>sys</sub> + 200		ns
			$\overline{SCK0}$ output mode	100		ns
$\overline{SCK0} \downarrow \rightarrow SO0$ delay time	t <sub>kSO</sub>	SO0	$\overline{SCK0}$ input mode		t <sub>sys</sub> + 200	ns
			$\overline{SCK0}$ output mode		100	ns

**Note 1** t<sub>sys</sub> indicates the three values below according to the upper two bits (CPU clock selection) of the clock control register (address: 00FEH).

t<sub>sys</sub> [ns] = 2000/fc (upper two bits = "00"), 4000/fc (upper two bits = "01"), 16000/fc (upper two bits = "11")

**Note 2** The load condition for the  $\overline{SCK0}$  output mode, SO0 output delay time is 50pF + 1TTL.

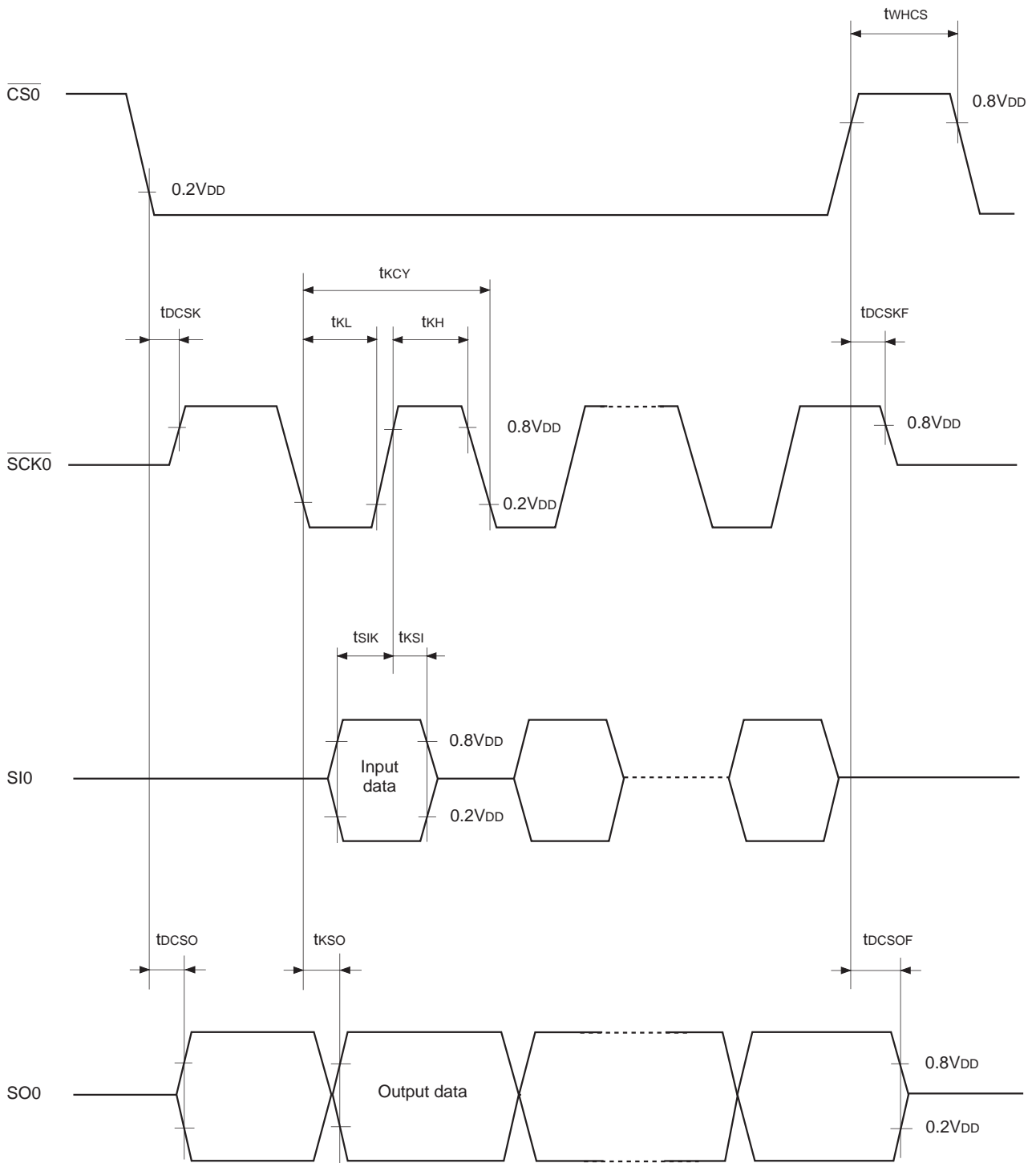

Fig. 4. Serial transfer CH0 timing

**Serial transfer (CH1)**

( $T_a = -20$  to  $+75^\circ\text{C}$ ,  $V_{DD} = 4.5$  to  $5.5\text{V}$ ,  $V_{SS} = 0\text{V}$  reference)

Item	Symbol	Pin	Condition	Min.	Max.	Unit
$\overline{\text{SCK1}}$ cycle time	$t_{\text{KCY}}$	$\overline{\text{SCK1}}$	Input mode	1000		ns
			Output mode	$16000/f_c$		ns
$\overline{\text{SCK1}}$ High, Low level width	$t_{\text{KH}}, t_{\text{KL}}$	$\overline{\text{SCK1}}$	Input mode	400		ns
			Output mode	$8000/f_c - 50$		ns
SI1 input setup time (for $\overline{\text{SCK1}} \uparrow$ )	$t_{\text{SIK}}$	SI1	$\overline{\text{SCK1}}$ input mode	100		ns
			$\overline{\text{SCK1}}$ output mode	200		ns
SI1 input hold time (for $\overline{\text{SCK1}} \uparrow$ )	$t_{\text{KSI}}$	SI1	$\overline{\text{SCK1}}$ input mode	200		ns
			$\overline{\text{SCK1}}$ output mode	100		ns
$\overline{\text{SCK1}} \downarrow \rightarrow \text{SO1}$ delay time	$t_{\text{KSO}}$	SO1	$\overline{\text{SCK1}}$ input mode		200	ns
			$\overline{\text{SCK1}}$ output mode		100	ns

**Note)** The load condition for the  $\overline{\text{SCK1}}$  output mode, SO1 output delay time is  $50\text{pF} + 1\text{TTL}$ .

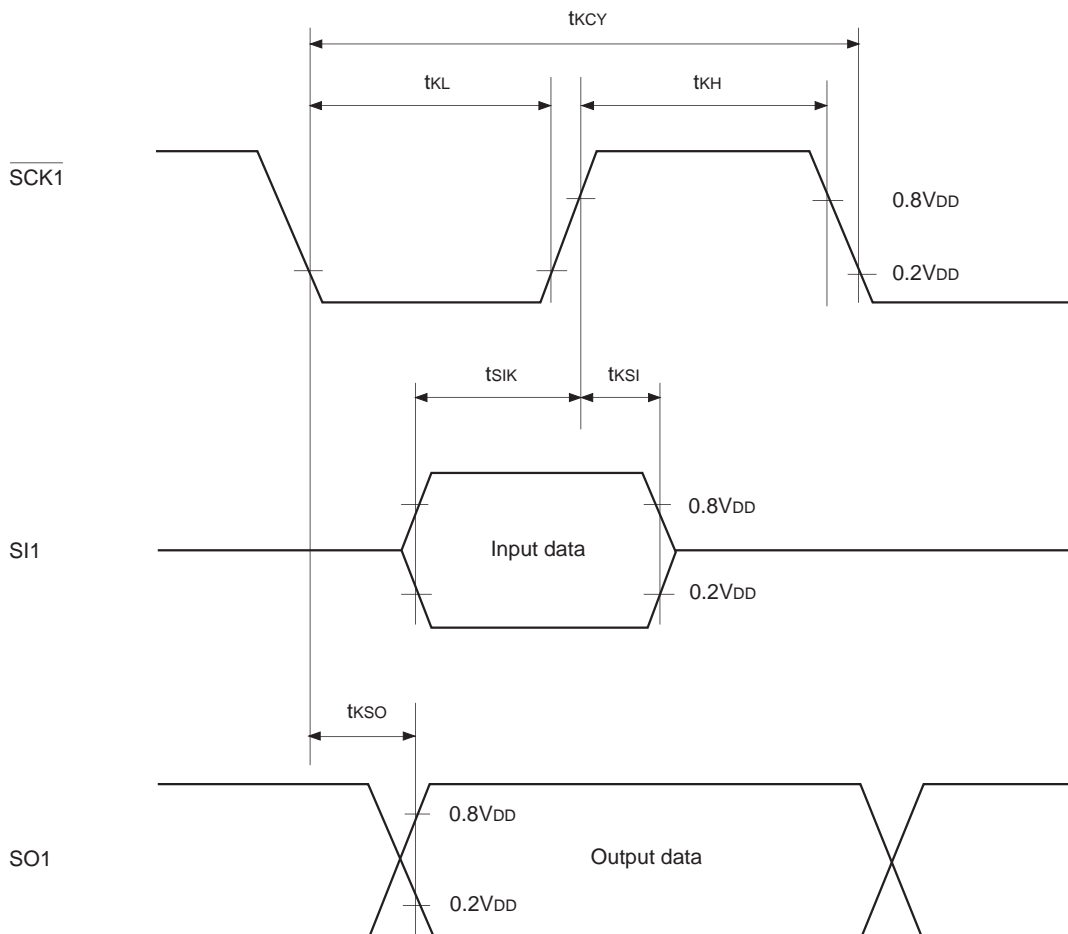
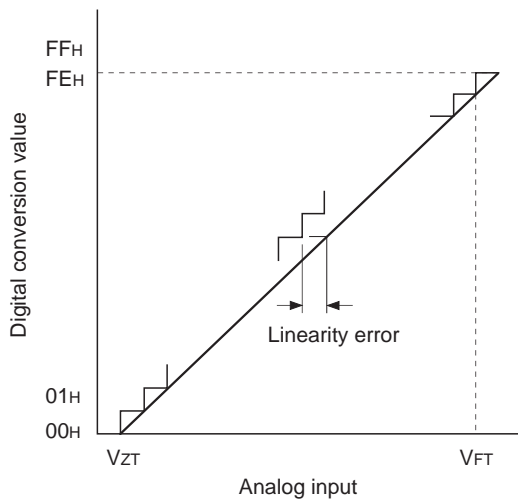

**Fig. 5. Serial transfer CH1 timing**

**(3) A/D converter characteristics**

( $T_a = -20$  to  $+75^\circ\text{C}$ ,  $V_{DD} = 4.5$  to  $5.5\text{V}$ ,  $AV_{REF} = 4.0$  to  $AV_{DD}$ ,  $V_{SS} = AV_{SS} = 0\text{V}$  reference)

Item	Symbol	Pin	Condition	Min.	Typ.	Max.	Unit
Resolution						8	Bits
Linearity error			$T_a = 25^\circ\text{C}$ $V_{DD} = 5.0\text{V}$ $V_{SS} = AV_{SS} = 0\text{V}$			$\pm 5$	LSB
Zero transition voltage	$V_{ZT}^{*1}$			-10	70	150	mV
Full-scale transition voltage	$V_{FT}^{*2}$			4930	5050	5120	mV
Conversion time	$t_{CONV}$			$160/f_{ADC}^{*3}$			$\mu\text{s}$
Sampling time	$t_{SAMP}$			$12/f_{ADC}^{*3}$			$\mu\text{s}$
Reference input voltage	$V_{REF}$	$AV_{REF}$		$V_{DD} - 0.5$		$V_{DD}$	V
Analog input voltage	$V_{IAN}$	$AN0$ to $AN7$		0		$AV_{REF}$	V
$AV_{REF}$ current	$I_{REF}$	$AV_{REF}$	Operation mode		0.6	1.0	mA
	$I_{REFS}$		Sleep mode Stop mode 32kHz operation mode			10	$\mu\text{A}$



- \*1  $V_{ZT}$  : Value at which the digital conversion value changes from 00H to 01H and vice versa.
- \*2  $V_{FT}$  : Value at which the digital conversion value changes from FEH to FFH and vice versa.
- \*3  $f_{ADC}$  indicates the below values due to ADC operation clock selection.  
 During PS2 selection,  $f_{ADC} = f_c/2$   
 During PS1 selection,  $f_{ADC} = f_c$

**Fig. 6. Definition of A/D converter terms**

**(4) Interruption, reset input** (Ta = -20 to +75°C, VDD = 4.5 to 5.5V, Vss = 0V reference)

Item	Symbol	Pins	Condition	Min.	Max.	Unit
External interruption High, Low level width	t <sub>IH</sub> t <sub>IL</sub>	INT0 INT1 INT2 INT3 $\overline{\text{NMI}}$ PJ0 to PJ7		1		μs
Reset input Low level width	t <sub>RSL</sub>	$\overline{\text{RST}}$		8/fc		μs

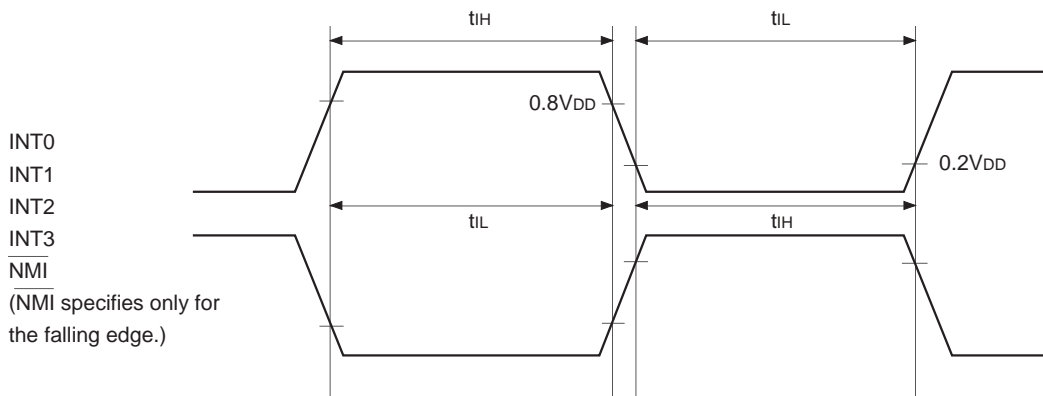

**Fig 7. Interruption input timing**

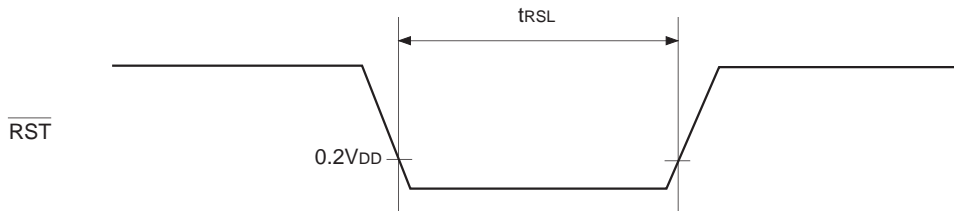

**Fig. 8.  $\overline{\text{RST}}$  input timing**

Appendix

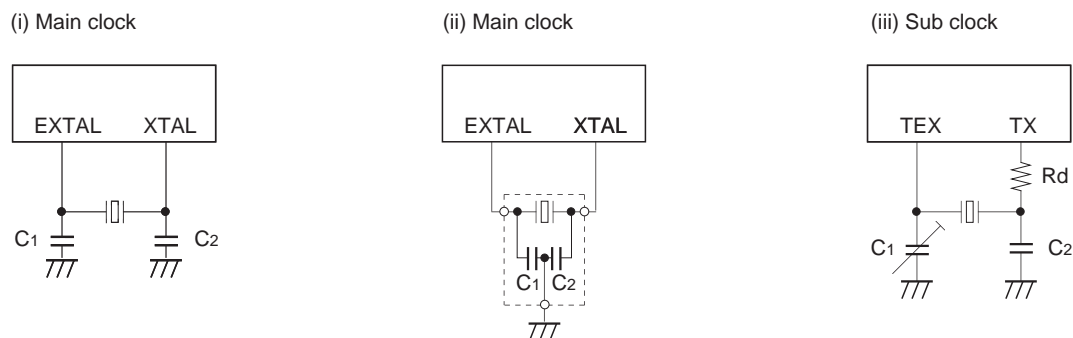

Fig. 9. SPC700 series recommended oscillation circuit

Manufacturer	Model	fc (MHz)	C1 (pF)	C2 (pF)	Circuit example
MURATA MFG CO., LTD.	CSA4.19MG	4.19	30	30	(i)
	CSA8.00MG	8.00			
	CSA10.0MT	10.00			
	CST4.19MGW*	4.19			(ii)
	CST8.00MTW*	8.00			
	CST10.00MTW*	10.00			
RIVER ELETEC CORPORATION	HC-49/U03	4.19	15	15	(i)
		8.00			
		10.00			
KINSEKI LTD.	HC-49/U (-S)	4.19	27	27	
		8.00			
		10.00			

Those marked with an asterisk (\*) signify types with built-in ground capacitance (C1, C2).

Mask option table

Item	Content	
	Reset pin pull-up resistance	Non-existent





LittleDiode supplies new, hard to find or obsolete electronic components and semiconductors all over the world.

With over two million different components listed you are sure to find the part you need.

Feel free to visit us today at our online store:

[LittleDiode.com](http://LittleDiode.com)

Looking forward to providing you with the best possible service.