

CMOS 8-bit Single Chip Microcomputer

Description

The CXP824P40A is a CMOS 8-bit single chip microcomputer integrating on a single chip an A/D converter, serial interface, timer/counter, time base timer, capture timer counter, fluorescent display tube, controller/driver, remote control reception circuit, CTL duty detection circuit, 14-bit PWM output and high-speed output circuit besides the basic configurations of 8-bit CPU, PROM, RAM, and I/O port.

The CXP824P40A also provides sleep/stop function that enables lower power consumption.

CXP824P40A is the PROM-incorporated version of the CXP82440A with built-in mask ROM. This provides the additional feature of being able to write directly into the program. Thus, it is most suitable for evaluation use during system development and for small-quantity production.

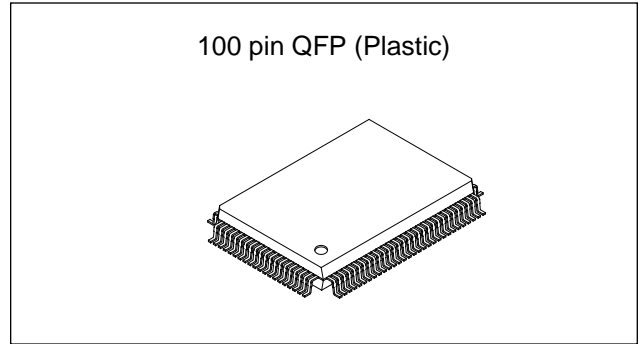

Structure

Silicon gate CMOS IC

Features

- Wide-range instruction system (213 instructions) to cover various types of data
 - 16-bit arithmetic/multiplication and division/boolean bit operation instructions
- Minimum instruction cycle
 - 400ns at 10MHz operation
 - 122µs at 32kHz operation
- Incorporated PROM capacity
 - 40K bytes
- Incorporated RAM capacity
 - 1120 bytes (including fluorescent display area)
- Peripheral functions
 - A/D converter
 - 8-bit, 8-channel, successive approximation method (Conversion time of 32µs/10MHz)
 - Incorporated 8-bit, 8-stage FIFO (Auto transfer for 1 to 8 bytes), 1 channel
 - 8-bit clock sync type, 1 channel
 - Serial interface
 - 8-bit timer, 8-bit timer/counter, 19-bit time base timer
 - 16-bit capture timer/counter, 32kHz timer/counter
 - Maximum of 384 segments display possible
 - 1 to 16-digit dynamic display
 - Dimmer function
 - High voltage drive output (40V)
 - On-chip pull-down resistor (Mask option)
 - Hardware key scan function (Maximum of 16 × 8 key matrix compatible)
 - Incorporated noise elimination circuit
 - 8-bit measurement counter with on-chip 6-stage FIFO
 - 14 bits, 1 channel
 - Timers
 - Fluorescent display tube controller/driver
- Remote control receiving circuit
- PWM output
- CTL duty detection circuit
- High-speed output circuit
- Interruption
 - RTG 4 pins
 - 19 factors, 15 vectors, multi-interruption possible
- Standby mode
 - SLEEP/STOP
- Package
 - 100-pin plastic QFP

Sony reserves the right to change products and specifications without prior notice. This information does not convey any license by any implication or otherwise under any patents or other right. Application circuits shown, if any, are typical examples illustrating the operation of the devices. Sony cannot assume responsibility for any problems arising out of the use of these circuits.

Block Diagram

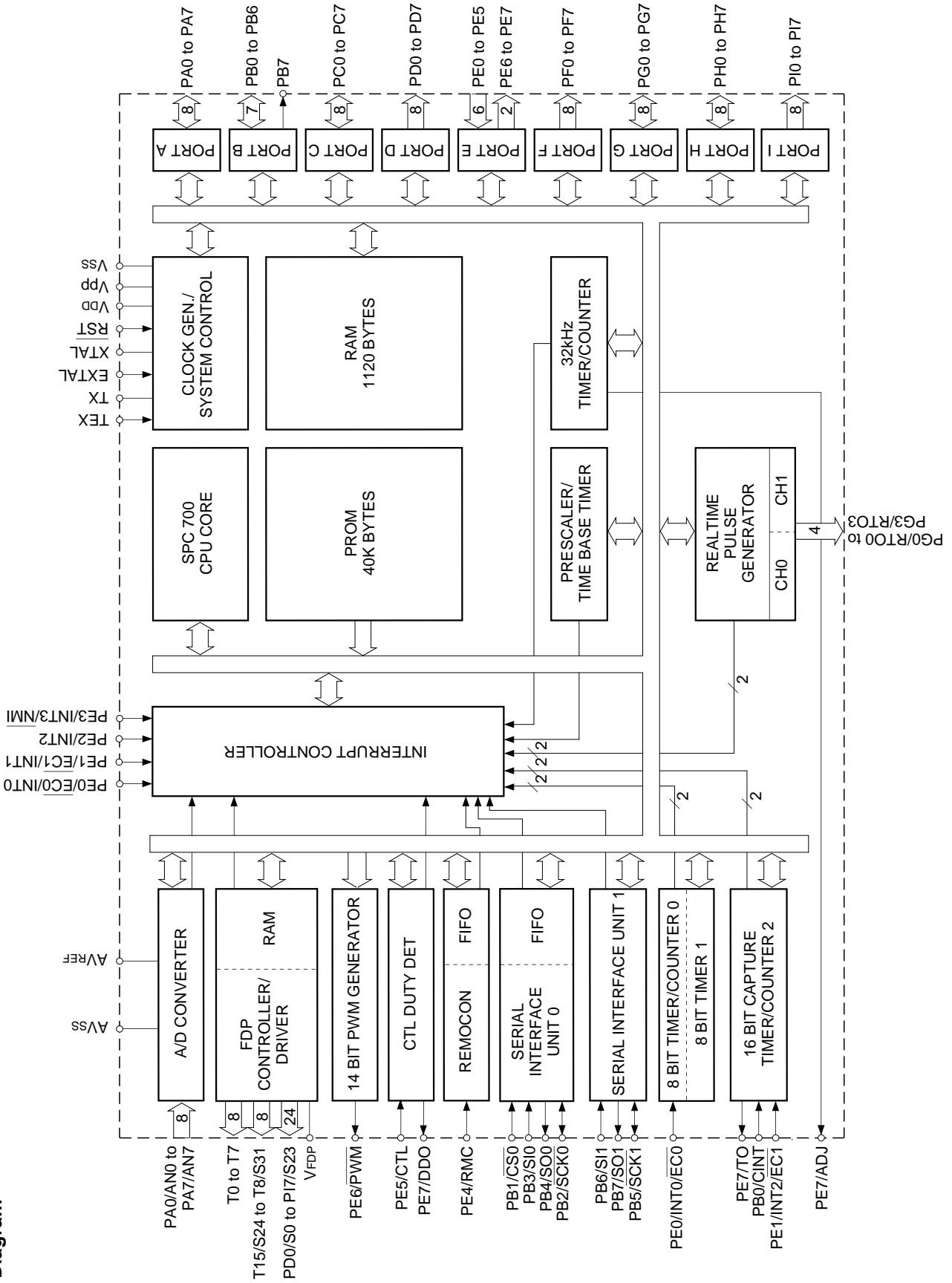

Pin Assignment (Top View)

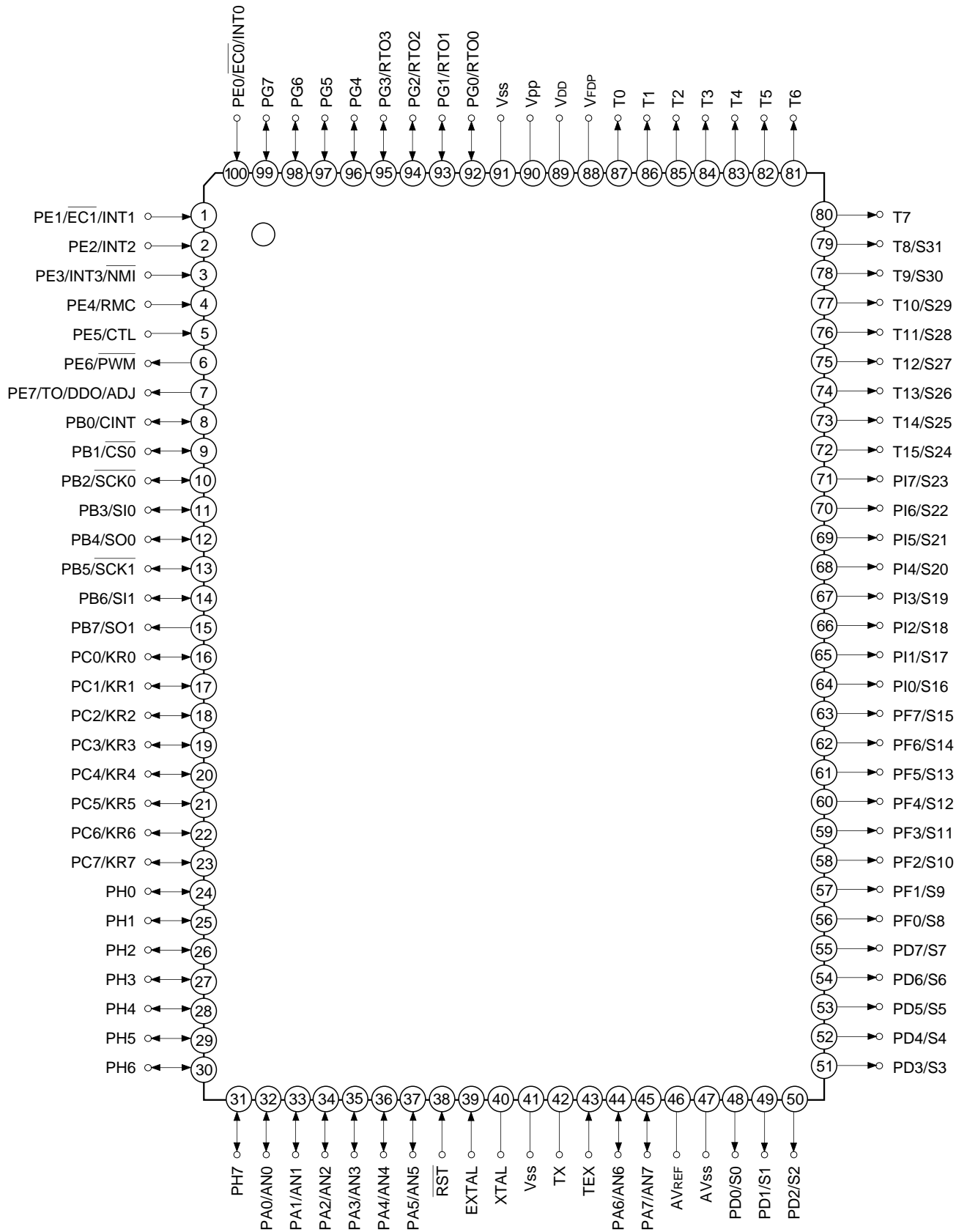

- Note)**
1. Vpp (Pin 90) must be connected to VDD.
 2. Vss (Pins 41 and 91) are both connected to GND.

Pin Description

Pin code	I/O		Functions	
PA0/AN0 to PA7/AN7	I/O/ Analog input	(Port A) 8-bit I/O port. I/O can be set in single bit units. (8 pins)	Analog inputs to A/D converter. (8 pins)	
PB0/CINT	I/O/Input	(Port B) 8-bit I/O port. I/O for lower 7 bits can be set in a unit of single bits. Uppermost bit (PB7) is for output only. (8 pins)	Capture input to 16-bit timer/counter.	
PB1/ $\overline{\text{CS0}}$	I/O/Input		Chip select input for serial interface (CH0).	
PB2/ $\overline{\text{SCK0}}$	I/O/I/O		Serial clock I/O (CH0).	
PB3/SI0	I/O/Input		Serial data input (CH0).	
PB4/SO0	I/O/Output		Serial data output (CH0).	
PB5/ $\overline{\text{SCK1}}$	I/O/I/O		Serial clock I/O (CH1).	
PB6/SI1	I/O/Input		Serial data input (CH1).	
PB7/SO1	Output/Output		Serial data output (CH1).	
PC0/KR0 to PC7/KR7	I/O/Input	(Port C) 8-bit I/O port. I/O can be set in a unit of single bits. Capable of driving 12mA sync current. (8 pins)	Serves as key return inputs when operating key scan with FDP segment signal.	
PD0/S0 to PD7/S7	Output/Output	(Port D) 8-bit output port. (8 pins)	FDP segment signal outputs.	
PE0/INT0/ $\overline{\text{EC0}}$	Input/Input/Input	(Port E) 8-bit port. Lower 6 bits are for inputs; upper 2 bits are for outputs. (8 pins)	Inputs for external interruption request. (4 pins)	External event inputs for timer/counter. (2 pins)
PE1/INT1/ $\overline{\text{EC1}}$	Input/Input/Input			Non-maskable interruption request input.
PE2/INT2	Input/Input		Remote control reception circuit input.	
PE3/INT3/ NMI	Input/Input/Input		Input for CTL duty direction circuit.	
PE4/RMC	Input/Input		14-bit PWM output.	
PE5/CTL	Input/Input		Output for the 16-bit timer/counter rectangular waves, CTU duty detection, and 32kHz oscillation frequency demultiplication.	
PE6/ $\overline{\text{PWM}}$	Output/Output			
PE7/TO/ DDO/ADJ	Output/Output/ Output/Output			
PF0/S8 to PF7/S15	Output/Output	(Port F) 8-bit output port. (8 pins)	FDP segment signal outputs.	
PG0/RTO0 to PG3/RTO3	I/O/Output	(Port G) 8-bit I/O port. I/O can be set in a unit of single bits. Data for the lower 4 bits are gated with the	Outputs for real-time pulse generator (RTG). Functions as high-precision, real-time pulse output port. (4 pins)	
PG4 to PG7	I/O	contents of RTO or OR-gate output. (8 pins)		

Pin code	I/O	Functions	
PH0 to PH7	I/O	(Port H) 8-bit I/O port. I/O can be set in a unit of single bits. (8 pins)	
PI0/S16 to PI7/S23	Output/Output	(Port I) 8-bit output ports. (8 pins)	FDP segment signal outputs.
T8/S31 to T15/S24	Output/Output	Outputs for FDP timing (digit) signals/segment signals.	
T0 to T7	Output	FDP timing signal outputs.	
V _{FDP}		FDP voltage supply when incorporated resistor is set by mask option.	
EXTAL	Input	Crystal connectors system clock oscillation. When the clock is supplied externally, input to EXTAL; opposite phase clock should be input to XTAL.	
XTAL	Output		
TEX	Input	Crystal connectors for 32kHz timer/counter clock oscillation. Set 32kHz crystal oscillator between TEX and TX. For usage as event input, attach clock source to TEX, and open TX.	
TX	Output		
R $\overline{S}T$	Input	Low-level active, system reset.	
AV _{REF}	Input	Reference voltage input for A/D converter.	
AV _{SS}		A/D converter GND.	
V _{DD}		V _{CC} supply.	
V _{pp}		V _{CC} supply for incorporated PROM writing. Connect to V _{DD} during normal operation.	
V _{SS}		GND.	

I/O Circuit Format for Pins

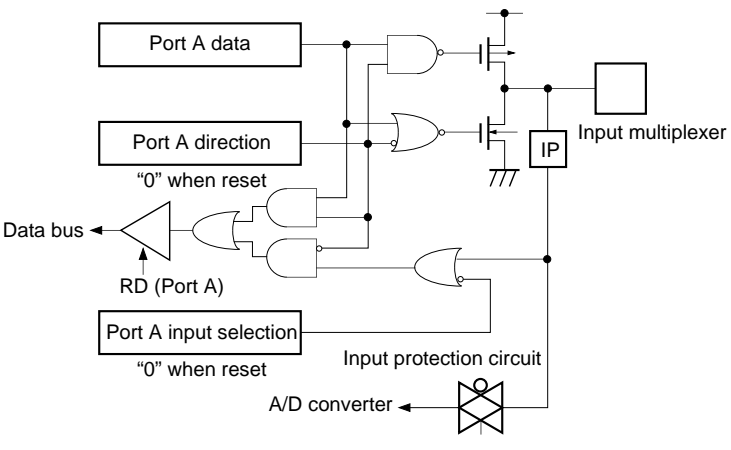
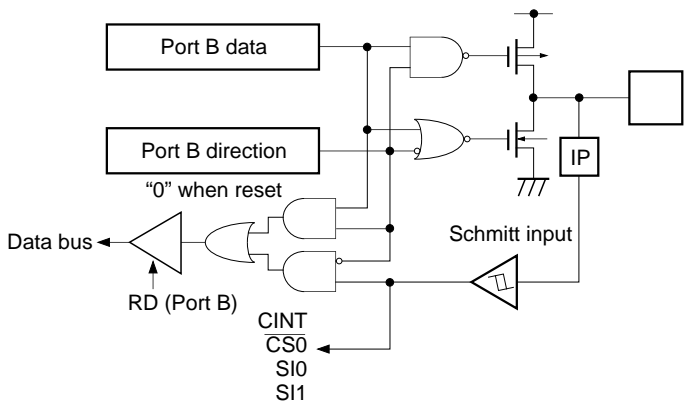
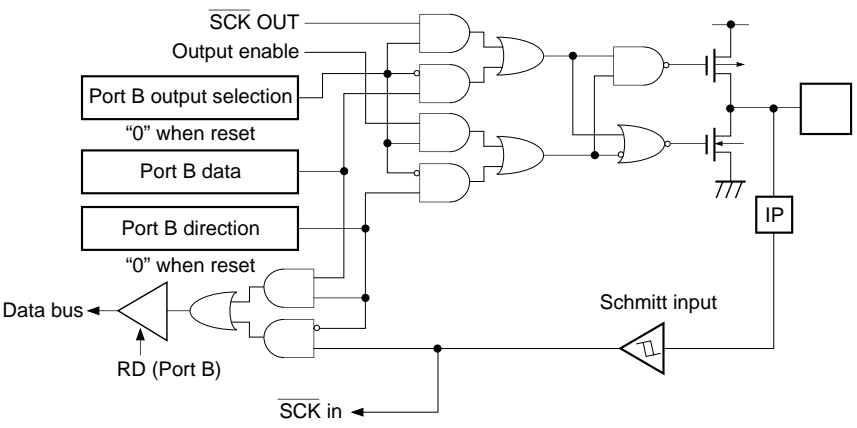
Pin	Circuit format	When reset
<p>PA0/AN0 to PA7/AN7</p> <p>8 pins</p>	<p>Port A</p> 	<p>Hi-Z</p>
<p>PB0/CINT PB1/CS0 PB3/SI0 PB6/SI1</p> <p>4 pins</p>	<p>Port B</p> 	<p>Hi-Z</p>
<p>PB2/SCK0 PB5/SCK1</p> <p>2 pins</p>	<p>Port B</p> 	<p>Hi-Z</p>

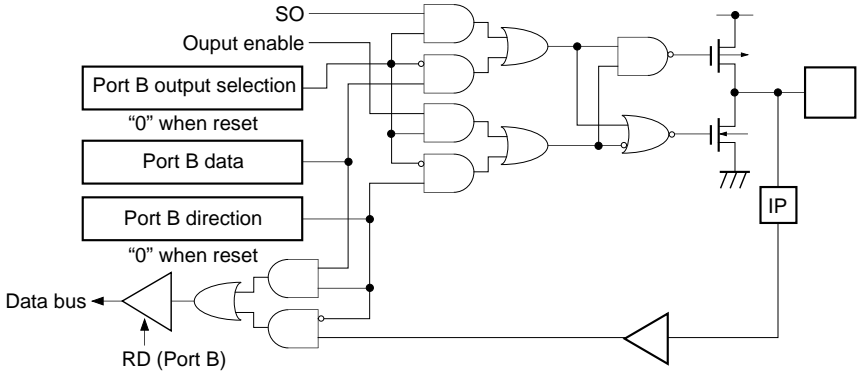
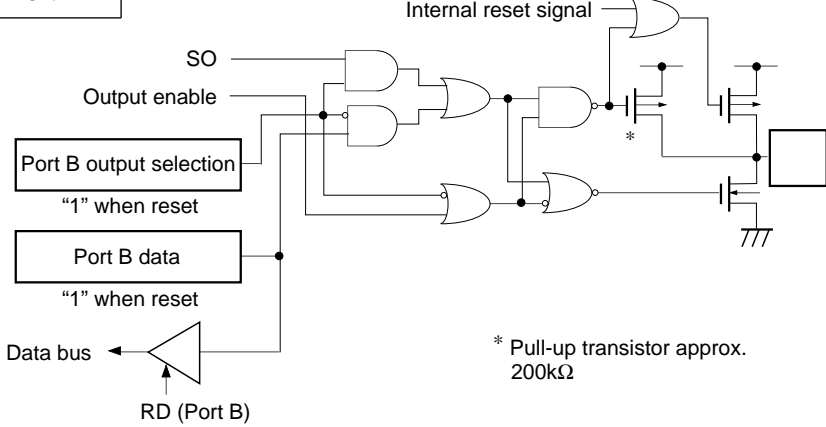
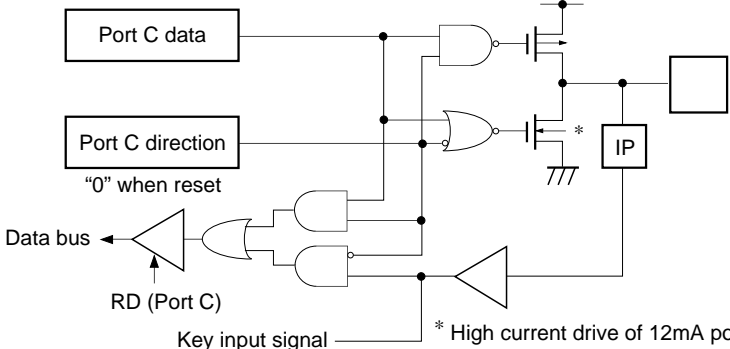
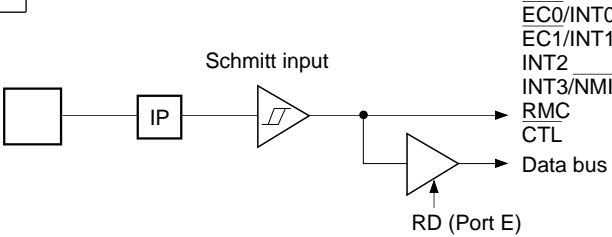
Pin	Circuit format	When reset
<p>PB4/SO0</p> <p>1 pin</p>	<p>Port B</p>  <p>SO</p> <p>Output enable</p> <p>Port B output selection "0" when reset</p> <p>Port B data</p> <p>Port B direction "0" when reset</p> <p>Data bus ←</p> <p>RD (Port B)</p> <p>IP</p>	<p>Hi-Z</p>
<p>PB7/SO1</p> <p>1 pin</p>	<p>Port B</p>  <p>SO</p> <p>Output enable</p> <p>Port B output selection "1" when reset</p> <p>Port B data "1" when reset</p> <p>Data bus ←</p> <p>RD (Port B)</p> <p>Internal reset signal</p> <p>* Pull-up transistor approx. 200kΩ</p>	<p>High level</p>
<p>PC0/KR0 to PC7/KR7</p> <p>8 pins</p>	<p>Port C</p>  <p>Port C data</p> <p>Port C direction "0" when reset</p> <p>Data bus ←</p> <p>RD (Port C)</p> <p>Key input signal</p> <p>IP</p> <p>* High current drive of 12mA possible</p>	<p>Hi-Z</p>
<p>PE0/$\overline{\text{EC0}}$/INT0 PE1/$\overline{\text{EC1}}$/INT1 PE2/INT2 PE3/INT3/$\overline{\text{NMI}}$ PE4/RMC PE4/$\overline{\text{CTL}}$</p> <p>6 pins</p>	<p>Port E</p>  <p>Schmitt input</p> <p>IP</p> <p>RD (Port E)</p> <p>$\overline{\text{EC0}}$/INT0 EC1/INT1 INT2 INT3/$\overline{\text{NMI}}$ RMC CTL</p> <p>Data bus</p>	<p>Hi-Z</p>

Pin	Circuit format	When reset
<p>PE6/PWM</p> <p>1 pin</p>		<p>High level</p>
<p>PE7/TO/ DDO/ADJ</p> <p>1 pin</p>	<p>* ADJ signal is a frequency demultiplication output for 32kHz oscillation frequency adjustment. ADJ2 can be used for buzzer output.</p>	<p>High level</p>
<p>PG0/RTO0 to PG3/RTO3</p> <p>4 pins</p>		<p>Hi-Z</p>
<p>PG4 to PG7 PH0 to PH7</p> <p>12 pins</p>		<p>Hi-Z</p>

Pin	Circuit format	When reset
<p>PD0/S0 to PD7/S7</p> <p>PF0/S8 to PF7/S15</p> <p>PI0/S16 to PI7/S23</p> <p>24 pins</p>	<p>Port D</p> <p>Port F</p> <p>Port I</p> <p>Segment output data</p> <p>Output selection control signal ("0" when reset)</p> <p>Data for Port D, F, or I "0" when reset</p> <p>Data bus</p> <p>RD (Port D, F, or I)</p> <p>* High voltage drive transistor</p> <p>Mask option</p> <p>Pull-down resistor</p> <p>V_{FDP}</p>	<p>Hi-Z or Low level (when PD resistance is added)</p>
<p>T15/S24 to T8/S31</p> <p>T0 to T7</p> <p>16 pins</p>	<p>Segment output data</p> <p>Output selection control signal ("0" when reset)</p> <p>* High voltage drive transistor</p> <p>Mask option</p> <p>Pull-down resistor</p> <p>V_{FDP}</p>	<p>Hi-Z or Low level (when PD resistance is added)</p>
<p>EXTAL XTAL</p> <p>2 pins</p>	<p>EXTAL</p> <p>XTAL</p> <p>IP</p> <p>IP</p> <ul style="list-style-type: none"> • Diagram shows circuit composition during oscillation. • Feedback resistor is removed during stop. 	<p>Oscillation</p>
<p>TEX TX</p> <p>2 pins</p>	<p>TEX</p> <p>TX</p> <p>IP</p> <p>IP</p> <ul style="list-style-type: none"> • Diagram shows circuit composition during oscillation. • When the operation of the oscillation circuit is stopped by the software, the feedback resistor is removed, and TEX and TX become "Low" level and "High" level respectively. 	<p>Oscillation</p>
<p>R\overlineST</p> <p>1 pin</p>	<p>Pull-up resistor</p> <p>Mask option</p> <p>Schmitt input</p>	<p>Hi-Z or High level (when pull-up resistance is added)</p>

Absolute Maximum Ratings

(V_{SS} = 0V reference)

Item	Symbol	Rating	Unit	Remarks
Supply voltage	V _{DD}	-0.3 to +7.0	V	
	V _{pp}	-0.3 to +13.0	V	Incorporated PROM
	AV _{SS}	-0.3 to +0.3	V	
Input voltage	V _{IN}	-0.3 to +7.0* ¹	V	
Output voltage	V _{OUT}	-0.3 to +7.0* ¹	V	
Display output voltage	V _{OD}	V _{DD} - 40 to V _{DD} + 0.3	V	As P channel transistor is open drain, V _{DD} is reference.
High level output current	I _{OH}	-5	mA	All pins excluding outputs* ² (value per pin)
	I _{ODH1}	-15	mA	Display outputs S0 to S23 (value per pin)
	I _{ODH2}	-35	mA	Display outputs T0 to T7, and T8/S31 to T15/S24 (value per pin)
High level total output current	∑I _{OH}	-40	mA	Total for all pins excluding display outputs
	∑I _{ODH}	-100	mA	Total for all display outputs
Low level output current	I _{OL}	15	mA	Port 1
	I _{OLC}	20	mA	High current Port 1* ³
Low level total output current	∑I _{OL}	100	mA	Total for all output pins
Operating temperature	T _{opr}	-20 to +75	°C	
Storage temperature	T _{stg}	-55 to +150	°C	
Allowable power dissipation	P _D	600	mW	

*1) V_{IN} and V_{OUT} must not exceed V_{DD} + 0.3V.

*2) Specifies output current of general-purpose I/O ports.

*3) The high current drive transistor is the N-CH transistor of Port C (PC).

Note) Usage exceeding absolute maximum ratings may permanently impair the LSI. Normal operation should be conducted under the recommended operating conditions. Exceeding these conditions may adversely affect the reliability of the LSI.

Recommended Operating Conditions

(V_{SS} = 0V reference)

Item	Symbol	Min.	Max.	Unit	Remarks
Supply voltage	V _{DD}	4.5	5.5	V	High-speed mode Guaranteed operation range
		3.5	5.5	V	Low-speed mode Guaranteed operation range
		2.7	5.5	V	Guaranteed operation range with TEX clock
		2.5	5.5	V	Guaranteed data hold range during STOP
	V _{pp}	V _{pp} = V _{DD}		V	*4
High level input voltage	V _{IH}	0.7V _{DD}	V _{DD}	V	*1
	V _{IHS}	0.8V _{DD}	V _{DD}	V	Hysteresis input*2
	V _{IHEX}	V _{DD} - 0.4	V _{DD} + 0.3	V	EXTAL*3
Low level input voltage	V _{IL}	0	0.3V _{DD}	V	*1
	V _{ILS}	0	0.2V _{DD}	V	Hysteresis input*2
	V _{ILEX}	-0.3	0.4	V	EXTAL*3
Operating temperature	T _{opr}	-10	+75	°C	

*1) Value for each pin of normal input port (PA, PB4, PC, PG, PH).

*2) Value of the following pins: $\overline{\text{RST}}$, CINT, $\overline{\text{CS0}}$, $\overline{\text{SCK0}}$, $\overline{\text{SCK1}}$, S10, S11, $\overline{\text{EC0/INT0}}$, $\overline{\text{EC1/INT1}}$, INT2, INT3/ $\overline{\text{NMI}}$, RMC, CTL.

*3) Specifies only during external clock input.

*4) V_{pp} and V_{DD} should be set a same voltage.

Electrical Characteristics

DC Characteristics

(Ta = -10 to +75°C, Vss = 0V reference)

Item	Symbol	Pins	Conditions	Min.	Typ.	Max.	Unit
High level output current	V _{OH}	PA, PB, PC, PE6, PE7, PG, PH	V _{DD} = 4.5V, I _{OH} = -0.5mA	4.0			V
			V _{DD} = 4.5V, I _{OH} = -1.2mA	3.5			V
Low level output current	V _{OL}	PA, PB, PC, PE6, PE7, PG, PH	V _{DD} = 4.5V, I _{OL} = 1.8mA			0.4	V
			V _{DD} = 4.5V, I _{OL} = 3.6mA			0.6	V
		PC	V _{DD} = 4.5V, I _{OL} = 12.0mA			1.5	V
Input current	I _{IHE}	EXTAL	V _{DD} = 5.5V, V _{IH} = 5.5V	0.5		40	μA
	I _{ILE}		V _{DD} = 5.5V, V _{IL} = 0.4V	-0.5		-40	μA
	I _{IHT}	TEX	V _{DD} = 5.5V, V _{IH} = 5.5V	0.1		10	μA
	I _{ILT}		V _{DD} = 5.5V V _{IL} = 0.4V	-0.1		-10	μA
	I _{I_{LR}}	RST	V _{DD} = 5.5V V _{IL} = 0.4V	-1.5		-400	μA
Display output current	I _{OH}	S0 to S23		-8			mA
		S24/T15 to S31/T8, T0 to T7	V _{DD} = 4.5V V _{OH} = V _{DD} - 2.5V	-20			mA
Open drain output leakage current (P-CH Tr off state)	I _{LOL}	S24/T15 to S31/T8, T0 to T7	V _{DD} = 5.5V V _{OL} = V _{DD} - 35V V _{FDP} = V _{DD} - 35V			-20	μA
Pull-down resistance	R _L	S24/T15 to S31/T8, T0 to T7	V _{DD} = 5V V _{FDP} = V _{DD} - 35V	60	100	270	kΩ
I/O leakage current	I _{Iz}	PA to PC, PE, PG, PH	V _{DD} = 5.5V V _I = 0, 5.5V			±10	μA

Item	Symbol	Pins	Conditions	Min.	Typ.	Max.	Unit
Power supply current*	I _{DD1}	V _{DD}	High speed mode operation (1/2 frequency demultiplier clock)		20	40	mA
			V _{DD} = 5.5V, 10MHz crystal oscillation (C ₁ = C ₂ = 15pF)				
	I _{DD2}		V _{DD} = 3V, 32kHz crystal oscillation (C ₁ = C ₂ = 47pF)		450	1100	μA
	I _{DDS1}		SLEEP mode		1.2	8	mA
			V _{DD} = 5.5V, 10MHz crystal oscillation (C ₁ = C ₂ = 15pF)				
	I _{DDS2}		V _{DD} = 3V, 32kHz crystal oscillation (C ₁ = C ₂ = 47pF)		9	30	μA
I _{DDS3}	STOP mode V _{DD} = 5.5V, 10MHz crystal oscillation; and termination of 32kHz oscillation				30	μA	
Input capacity	C _{IN}	Pins other than S0 to S31, T0 to T7, PB7, PE6, AVREF, AVSS, VFDP, V _{DD} , V _{SS}	Clock 1MHz 0V for all pins excluding measured pins		10	20	pF

* When all pins are open.

The leakage current is not specified because PB7 is dedicated for output.

AC Characteristics

(1) Clock timing

($T_a = -10$ to $+75^\circ\text{C}$, $V_{DD} = 4.5$ to 5.5V , $V_{SS} = 0\text{V}$ reference)

Item	Symbol	Pin	Conditions	Min.	Typ.	Max.	Unit
System clock frequency	f_c	XTAL EXTAL	Fig. 1, Fig. 2	1		10	MHz
System clock input pulse width	t_{XL} t_{XH}	EXTAL	Fig. 1, Fig. 2 External clock drive	37.5			ns
System clock input rise time, fall time	t_{CR} t_{CF}	EXTAL	Fig. 1, Fig. 2 External clock drive			200	ns
Event count input clock pulse width	t_{EH} t_{EL}	$\overline{EC0}$, $\overline{EC1}$	Fig. 3		$t_{sys} + 50^*$		ns
Event count input clock rise time, fall time	t_{ER} t_{EF}	$\overline{EC0}$, $\overline{EC1}$	Fig. 3			20	ms
System clock frequency	f_c	TEX TX	$V_{DD} = 2.7$ to 5.5V Fig. 2 (32kHz clock application condition)		32.768		kHz
Event count input pulse width	t_{TL} t_{TH}	TEX	Fig. 3	10			μs
Event count input rise time, fall time	t_{TR} t_{TF}	TEX	Fig. 3			20	ms

* t_{sys} indicates the three values below according to the upper two bits (CPU clock selection) of the control clock register (address: 00FEH).

t_{sys} (ns) = 2000/ f_c (upper two bits = "00"), 4000/ f_c (upper two bits = "01"), 16000/ f_c (upper two bits = "11")

Fig. 1. Clock timing

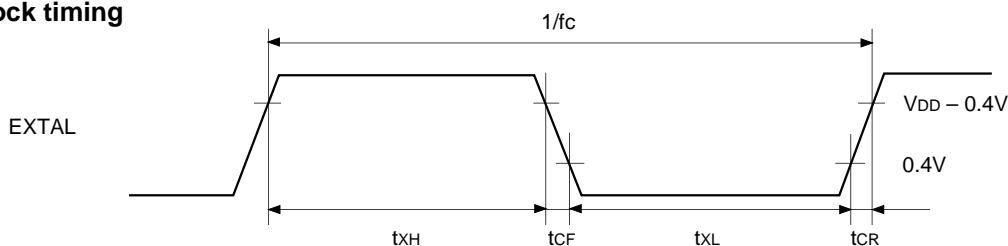

Fig. 2. Clock application conditions

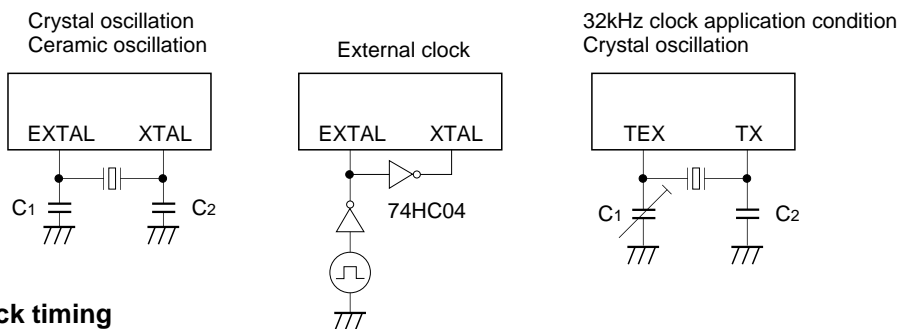
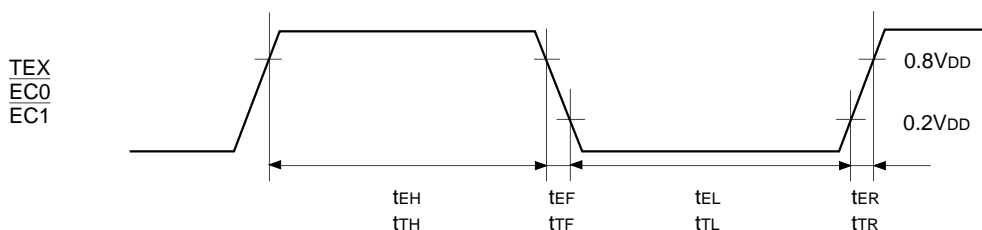

Fig. 3. Event count clock timing



(2) Serial transfer (CH0)

(Ta = -10 to +75°C, V_{DD} = 4.5 to 5.5V, V_{SS} = 0V reference)

Item	Symbol	Pin	Condition	Min.	Max.	Unit
$\overline{\text{CS0}} \downarrow \rightarrow \overline{\text{SCK0}}$ delay time	t _{bCSK}	$\overline{\text{SCK0}}$	Chip select transfer mode ($\overline{\text{SCK0}}$ = output mode)		t _{sys} + 200	ns
$\overline{\text{CS0}} \uparrow \rightarrow \overline{\text{SCK0}}$ float delay time	t _{bCSKF}	$\overline{\text{SCK0}}$	Chip select transfer mode ($\overline{\text{SCK0}}$ = output mode)		t _{sys} + 200	ns
$\overline{\text{CS0}} \uparrow \rightarrow \text{SO0}$ delay time	t _{bCSO}	SO0	Chip select transfer mode		t _{sys} + 200	ns
$\overline{\text{CS0}} \uparrow \rightarrow \text{SO0}$ float delay time	t _{bCSOF}	SO0	Chip select transfer mode		t _{sys} + 200	ns
$\overline{\text{CS0}}$ High level width	t _{WHCS}	$\overline{\text{CS0}}$	Chip select transfer mode	t _{sys} + 200		ns
$\overline{\text{SCK0}}$ cycle time	t _{kCY}	$\overline{\text{SCK0}}$	Input mode	2t _{sys} + 200		ns
			Output mode	16000/fc		ns
$\overline{\text{SCK0}}$ High, Low level width	t _{kH} t _{kL}	$\overline{\text{SCK0}}$	Input mode	t _{sys} + 100		ns
			Output mode	8000/fc - 50		ns
SI0 input set-up time (for $\overline{\text{SCK0}} \uparrow$)	t _{SIK}	SI0	$\overline{\text{SCK0}}$ input mode	100		ns
			$\overline{\text{SCK0}}$ output mode	200		ns
SI0 input hold time (for $\overline{\text{SCK0}} \uparrow$)	t _{ksi}	SI0	$\overline{\text{SCK0}}$ input mode	t _{sys} + 200		ns
			$\overline{\text{SCK0}}$ output mode	100		ns
$\overline{\text{SCK0}} \uparrow \rightarrow \text{SO0}$ delay time	t _{kso}	SO0	$\overline{\text{SCK0}}$ input mode		t _{sys} + 200	ns
			$\overline{\text{SCK0}}$ output mode		100	ns

Note 1) t_{sys} indicates the three values below according to the upper two bits (CPU clock selection) of the control clock register (address: 00FEH).

t_{sys} (ns) = 2000/fc (upper two bits = "00"), 4000/fc (upper two bits = "01"), 16000/fc (upper two bits = "11")

Note 2) The load condition for the $\overline{\text{SCK0}}$ output mode, SO0 output delay time is 50pF + 1TTL.

Fig. 4. Serial transfer CH0 timing

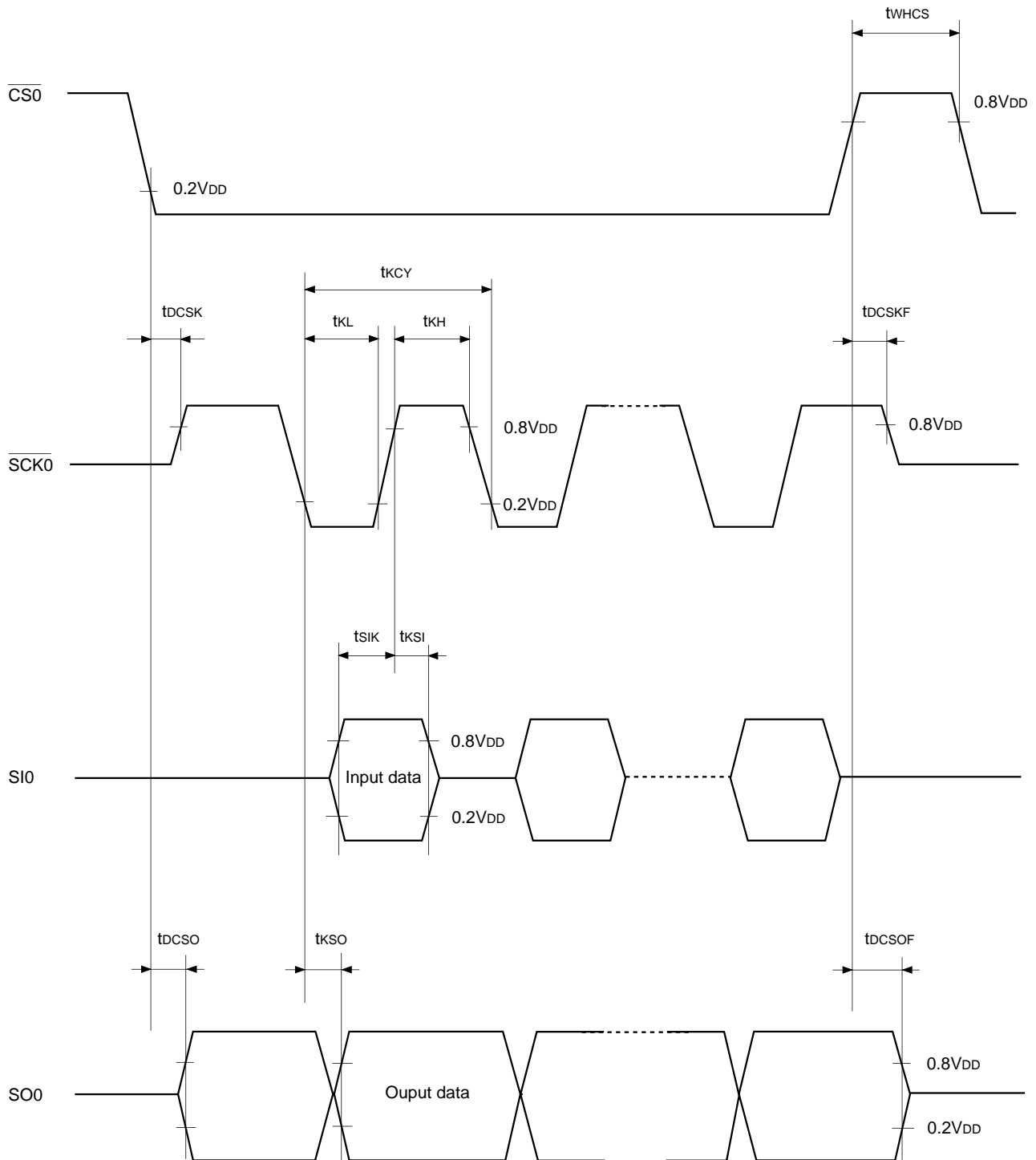

Serial transfer (CH1)

($T_a = -10$ to $+75^\circ\text{C}$, $V_{DD} = 4.5$ to 5.5V , $V_{SS} = 0\text{V}$ reference)

Item	Symbol	Pin	Condition	Min.	Max.	Unit
$\overline{\text{SCK1}}$ cycle time	t_{KCY}	$\overline{\text{SCK1}}$	Input mode	1000		ns
			Ouput mode	16000/fc		ns
$\overline{\text{SCK1}}$ High, Low level width	t_{KH} t_{KL}	$\overline{\text{SCK1}}$	Input mode	400		ns
			Ouput mode	8000/fc - 50		ns
SI1 input set-up time (for $\overline{\text{SCK1}} \uparrow$)	t_{SIK}	SI1	$\overline{\text{SCK1}}$ input mode	100		ns
			$\overline{\text{SCK1}}$ ouput mode	200		ns
SI1 input hold time (for $\overline{\text{SCK1}} \uparrow$)	t_{KSI}	SI1	$\overline{\text{SCK1}}$ input mode	200		ns
			$\overline{\text{SCK1}}$ ouput mode	100		ns
$\overline{\text{SCK1}} \downarrow \rightarrow \text{SO1}$ delay time	t_{KSO}	SO1	$\overline{\text{SCK1}}$ input mode		200	ns
			$\overline{\text{SCK1}}$ ouput mode		100	ns

Note) The load condition for the $\overline{\text{SCK1}}$ output mode, SO1 output delay time is $50\text{pF} + 1\text{TTL}$.

Fig. 5. Serial transfer CH1 timing

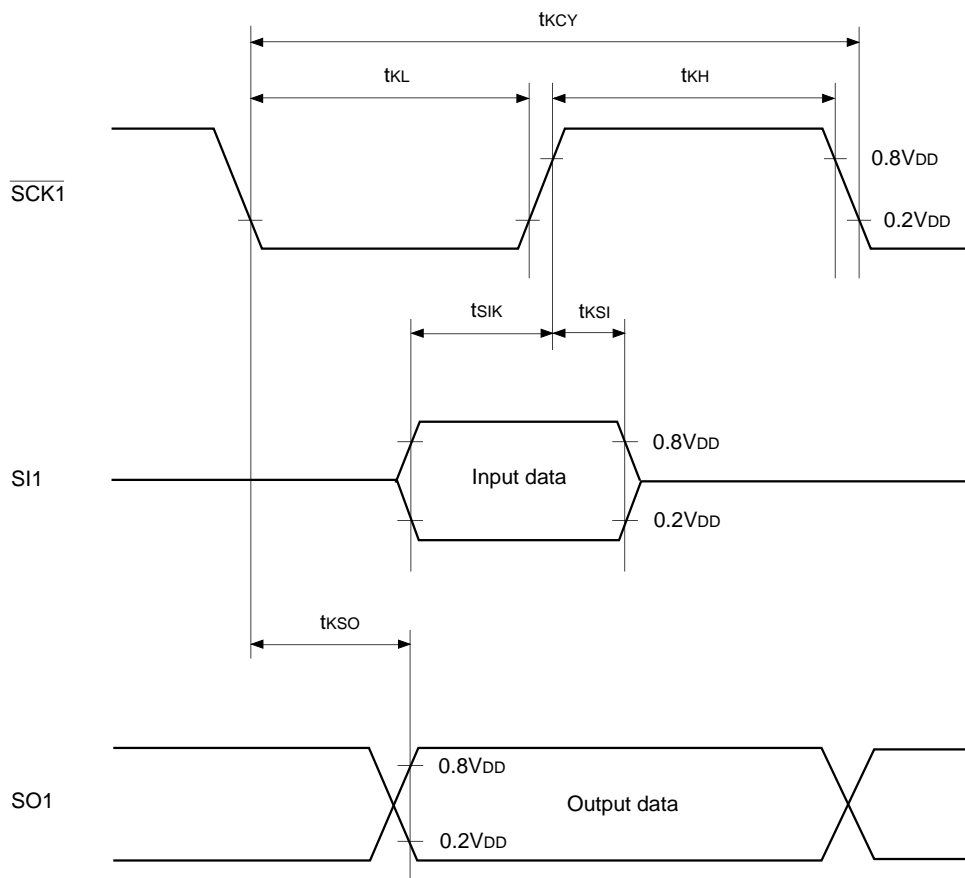

(3) A/D converter characteristics

($T_a = -10$ to $+75^\circ\text{C}$, $V_{DD} = 4.5$ to 5.5V , $AV_{REF} = 4.0$ to AV_{DD} , $V_{SS} = AV_{SS} = 0\text{V}$ reference)

Item	Symbol	Pin	Condition	Min.	Typ.	Max.	Unit
Resolution						8	Bits
Linearity error			$T_a = 25^\circ\text{C}$ $V_{DD} = 5.0\text{V}$ $V_{SS} = AV_{SS} = 0\text{V}$			± 3	LSB
Zero transition voltage	V_{ZT}^{*1}			-10	10	70	mV
Full-scale transition voltage	V_{FT}^{*2}			4910	4970	5030	mV
Conversion time	t_{CONV}			$160/f_{ADC}^{*3}$			μs
Sampling time	t_{SAMP}			$12/f_{ADC}^{*3}$			μs
Reference input voltage	V_{REF}	AV_{REF}		$V_{DD} - 0.5$		V_{DD}	V
Analog input voltage	V_{IAN}	$AN0$ to $AN7$		0		AV_{REF}	V
AV_{REF} current	I_{REF}	AV_{REF}	Operation mode		0.6	1.0	mA
	I_{REFS}		SLEEP mode STOP mode 32kHz operation mode			10	μA

Fig. 6. Definition of A/D converter terms

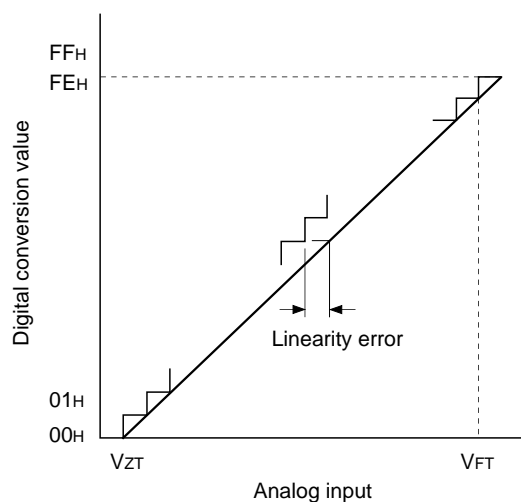

*1) V_{ZT} : Value at which the digital transfer value changes from 00H to 01H and vice versa.

*2) V_{FT} : Value at which the digital transfer value changes from FEH to FFH and vice versa.

*3) f_{ADC} indicates the below values due to ADC operation clock selection (ADCS: Bit 6 of address 00F9H).

During PS2 selection, $f_{ADC} = f_c/2$

During PS1 selection, $f_{ADC} = f_c$

(4) Interruption, reset input (Ta = -10 to +75°C, VDD = 4.5 to 5.5V, Vss = 0V reference)

Item	Symbol	Pin	Condition	Min.	Max.	Unit
External interruption High, Low level width	t _{IH} t _{IL}	INT0 INT1 INT2 $\overline{\text{NMI/INT3}}$		1		μs
Reset input Low level width	t _{RSL}	$\overline{\text{RST}}$		32/fc		μs

Fig. 7. Interruption input timing

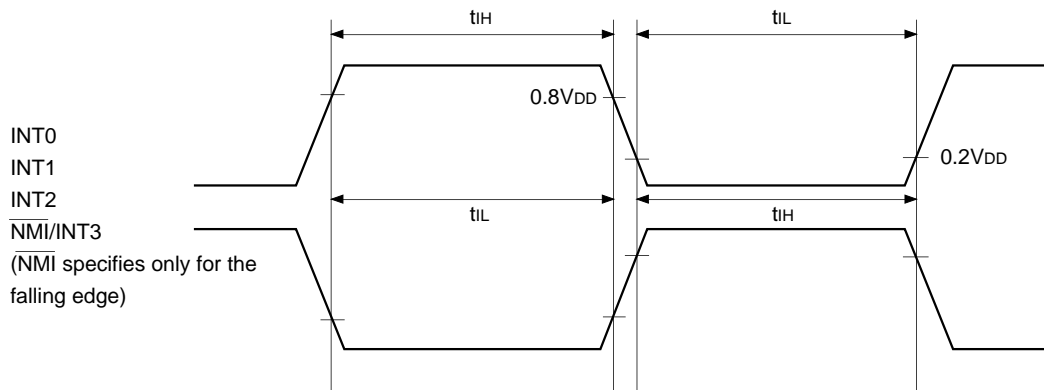
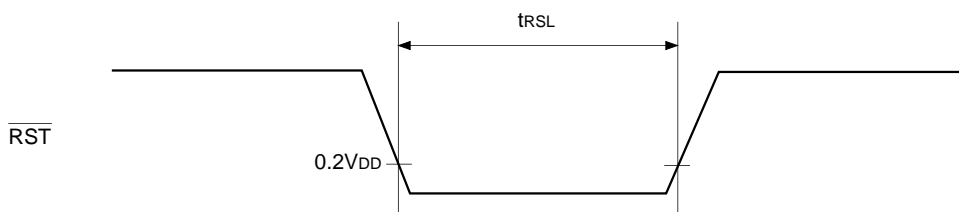

Fig. 8. $\overline{\text{RST}}$ input timing



(5) Others (Ta = -10 to +75°C, VDD = 4.5 to 5.5V, Vss = 0V reference)

Item	Symbol	Pin	Condition	Min.	Max.	Unit
CLK input High, Low level width	t _{CTH} t _{CTL}	CTL	t _{sys} = 2000/fc	t _{sys} + 200		ns

Fig. 9. Other timing

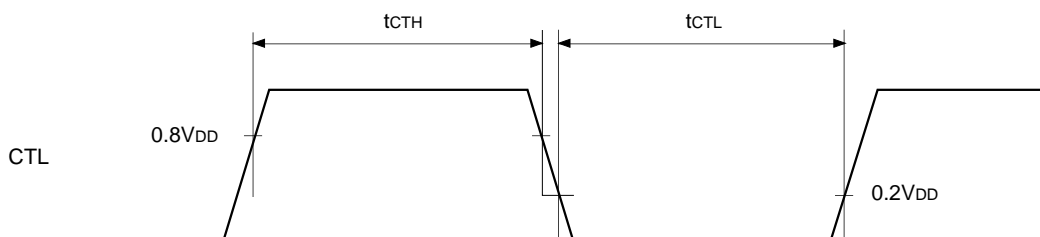

Appendix

Fig. 10. Recommended oscillation circuit

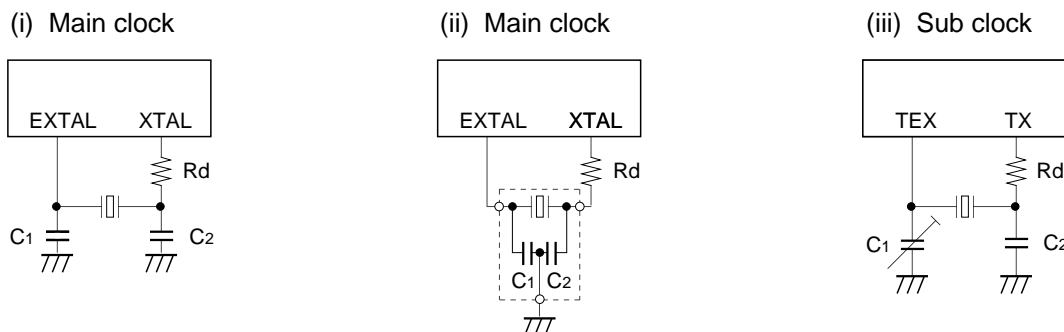

Manufacturer	Model	fc (MHz)	C1 (pF)	C2 (pF)	Rd (Ω)	Circuit example
MURATA MFG CO., LTD.	CSA4.19MG	4.19	30	30	0	(i)
	CSA8.00MTZ	8.00				
	CSA10.0MTZ	10.00				
	CST4.19MGW*	4.19				(ii)
	CST8.00MTW*	8.00				
	CST10.0MTW*	10.00				
RIVER ELETEC CO., LTD	HC-49/U03	4.19	12	12	0	(i)
		8.00				
		10.00				
KINSEKI LTD.	HC-49/U (-S)	4.19	27	27	0	
		8.00				
		10.00	20	20		
	P3	32.768kHz	50	22	1M	(iii)

Those marked with an asterisk (*) signify types with built-in ground capacitance (C1, C2).

Mask option table

Option	Mask product	CXP824P40Q-1-□□□
Package	100-pin plastic QFP	100-pin plastic QFP
ROM capacitance	32K bytes/40K bytes	PROM 40K bytes
Reset pin pull-up resistance	Existent/non-existent	Existent
High voltage drive pin pull-up resistor	Existent/non-existent	Non-existent (S0/PD0 to S23/PI7) Existent (T0 to T15/S24)

Package Outline

Unit: mm

100PIN QFP (PLASTIC)

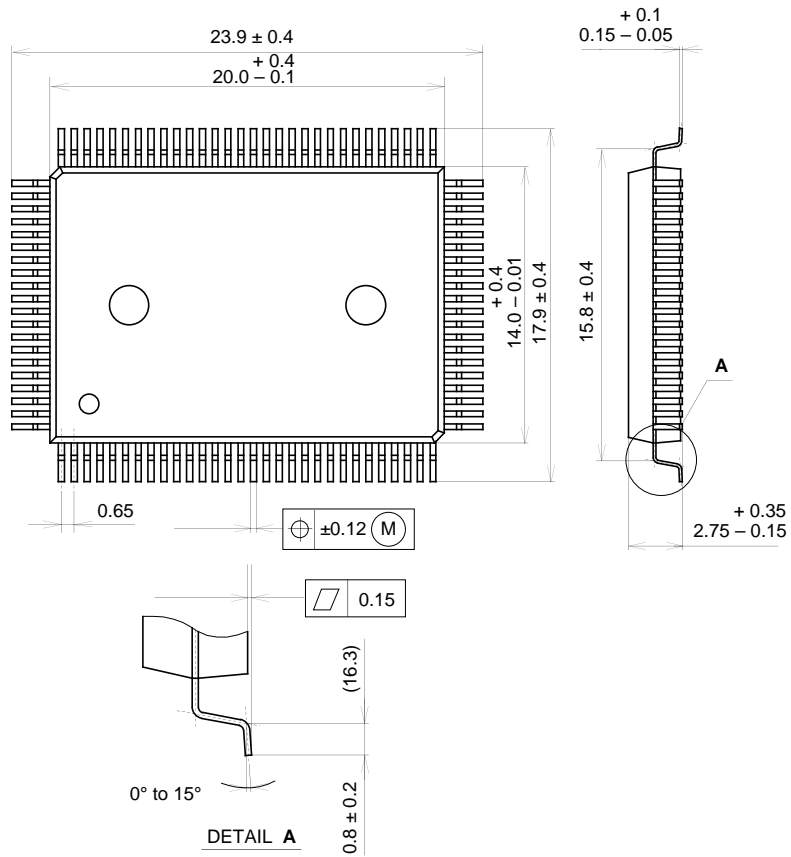

SONY CODE	QFP-100P-L01
EIAJ CODE	*QFP100-P-1420-A
JEDEC CODE	_____

PACKAGE STRUCTURE

PACKAGE MATERIAL	EPOXY RESIN
LEAD TREATMENT	SOLDER PLATING
LEAD MATERIAL	COPPER / 42 ALLOY
PACKAGE WEIGHT	1.4g



LittleDiode supplies new, hard to find or obsolete electronic components and semiconductors all over the world.

With over two million different components listed you are sure to find the part you need.

Feel free to visit us today at our online store:

LittleDiode.com

Looking forward to providing you with the best possible service.