

CMOS 8-bit Single Chip Microcomputer

Description

The CXP80712B/80716B/80720B/80724B is a CMOS 8-bit microcomputer which consists of A/D converter, serial interface, timer/counter, time base timer, high precision timing pattern generation circuit, PWM output, VISS/VASS circuit, 32kHz timer/counter, remote control receiving circuit, VSYNC separator and the measurement circuit which measures signals of capstan FG and drum FG/PG and other servo systems, as well as basic configurations like 8-bit CPU, ROM, RAM and I/O port. They are integrated into a single chip.

Also CXP80712B/80716B/80720B/80724B provides sleep/stop function which enables to lower power consumption.

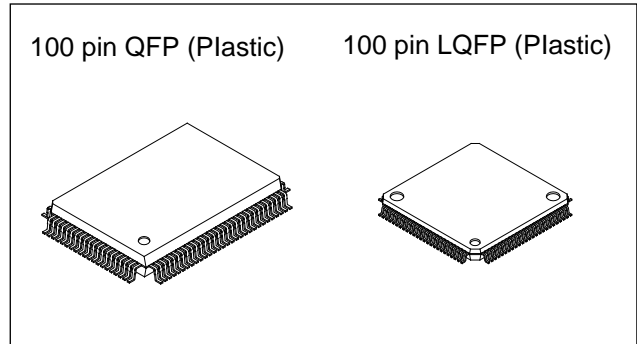

Structure

Silicon gate CMOS IC

Features

- A wide instruction set (213 instructions) which cover various types of data
 - 16-bit arithmetic/multiplication and division/boolean bit operation instructions
- Minimum instruction cycle
 - 250ns at 16MHz operation
 - 122µs at 32kHz operation
- Incorporated ROM capacity
 - 12K bytes (CXP80712B)
 - 16K bytes (CXP80716B)
 - 20K bytes (CXP80720B)
 - 24K bytes (CXP80724B)
- Incorporated RAM capacity
 - 800 bytes
- Peripheral functions
 - A/D converter
 - 8 bits, 12 channels, successive approximation system (Conversion time of 20.0µs/16MHz)
 - Serial Interface
 - Incorporated 8-bit and 8-stage FIFO, 1 channel (1 to 8 bytes auto transfer)
 - 8-bit serial I/O, 1 channel
 - Timer
 - 8-bit timer
 - 8-bit timer/counter
 - 19-bit time base timer
 - 32kHz timer/counter
 - High precision timing pattern generator
 - PPG for 19 pins, 32-stage programmable
 - RTG for 5 pins, 2 channels
 - PWM/DA gate output
 - 12 bits, 2 channels (Repetitive frequency of 62.5kHz/16MHz)
 - Servo input control
 - Capstan FG, Drum FG/PG, CTL input
 - VSYNC separator
 - Incorporated 26-bit and 8-stage FIFO
 - FRC capture unit
 - 14 bits, 1 channel
 - PWM output
 - Pulse duty auto detection circuit
 - VISS/VASS circuit
 - 8-bit pulse measurement counter, 6-stage FIFO
 - Remote control receiving circuit
 - 21 factors, 15 vectors, multi-interruption possible
- Interruption
 - SLEEP/STOP
- Standby mode
- Package
 - 100-pin plastic QFP/LQFP
 - CXP87700 100-pin ceramic PQFP
- Piggyback/evaluation chip

Sony reserves the right to change products and specifications without prior notice. This information does not convey any license by any implication or otherwise under any patents or other right. Application circuits shown, if any, are typical examples illustrating the operation of the devices. Sony cannot assume responsibility for any problems arising out of the use of these circuits.

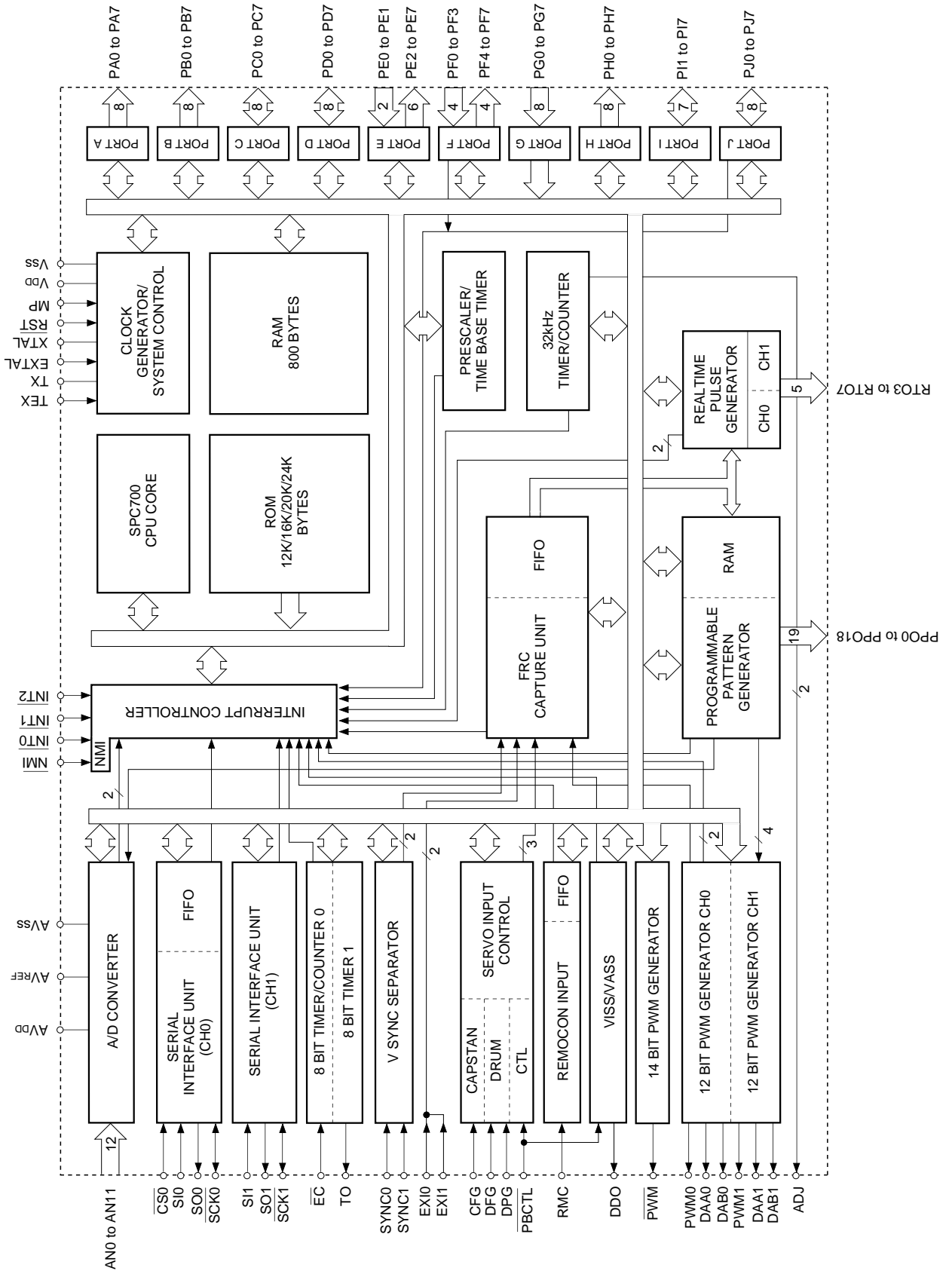

Block Diagram

Pin Assignment 1 (Top View) 100 pin QFP package

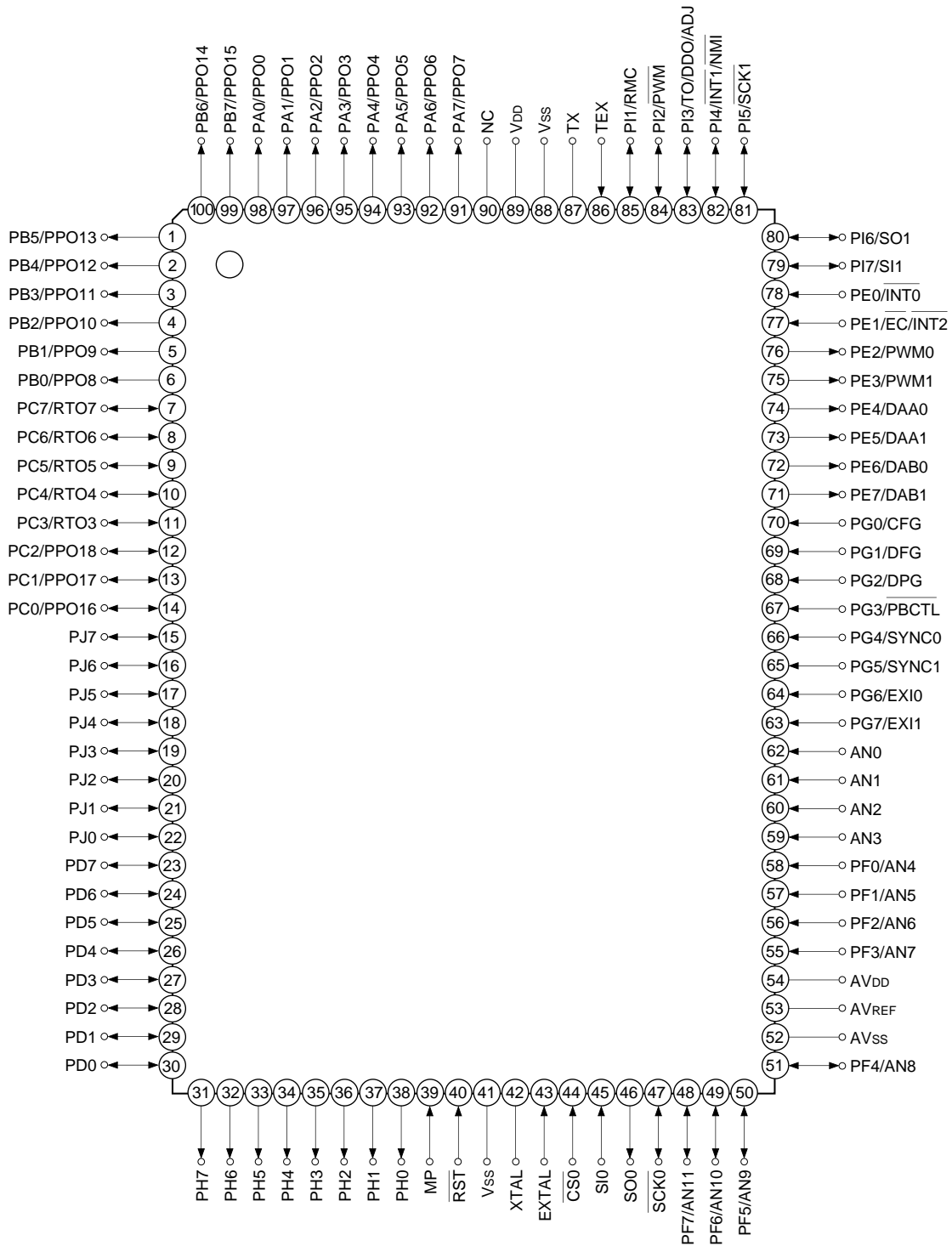

- Note)**
1. NC (Pin 90) is always connected to V_{DD}.
 2. V_{SS} (Pins 41 and 88) are both connected to GND.
 3. MP (Pin 39) is always connected to GND.

Pin Assignment 2 (Top View) 100 pin LQFP package

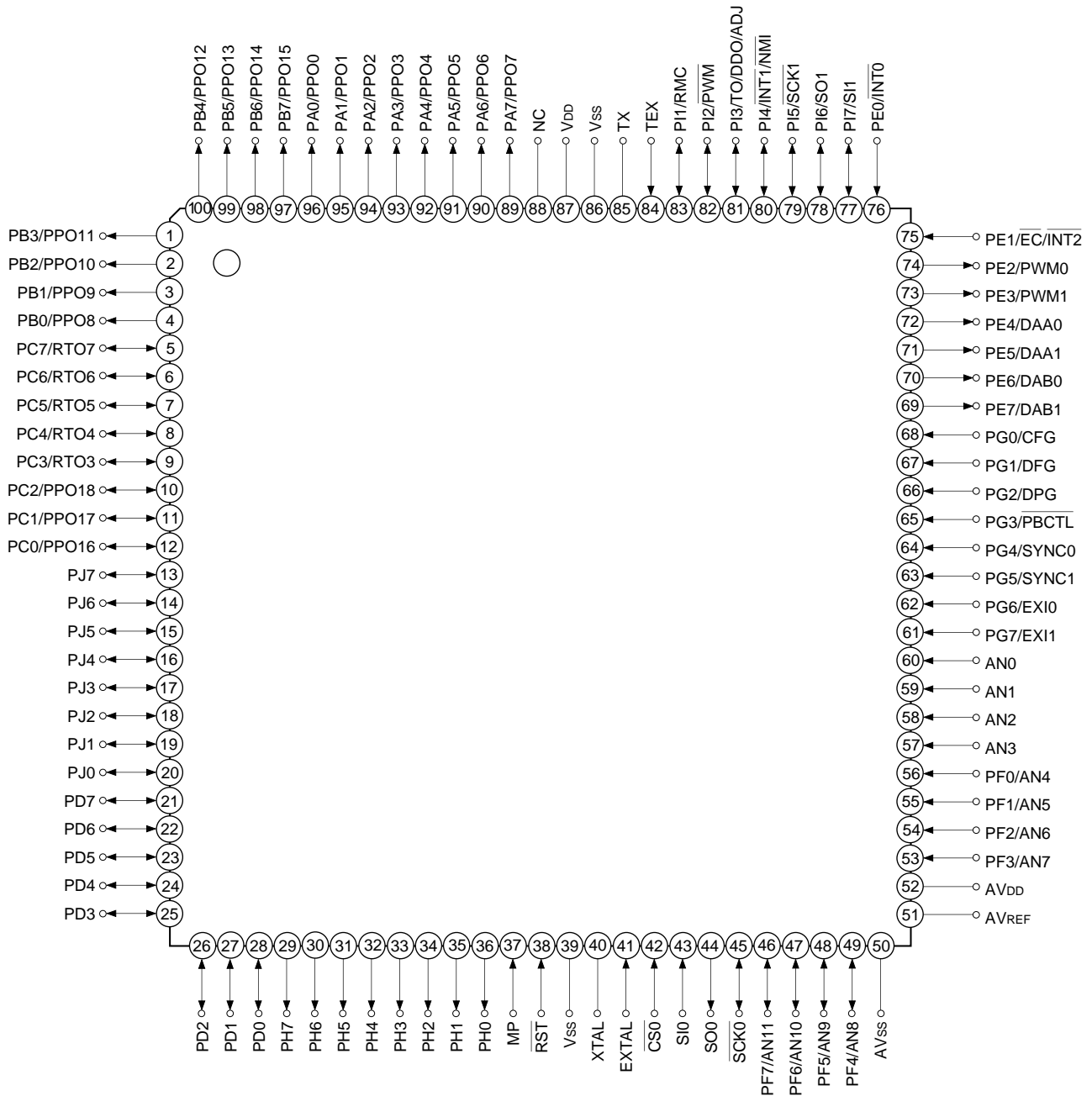

- Note)**
1. NC (Pin 88) is always connected to VDD.
 2. Vss (Pins 39 and 86) are both connected to GND.
 3. MP (Pin 37) is always connected to GND.

Pin Description

Symbol	I/O	Description		
PA0/PPO0 to PA7/PPO7	Output/Real-time output	(Port A) 8-bit output port. Data is gated with PPO contents by OR-gate and they are output. (8 pins)	Programmable pattern generator (PPG) output. Functions as high precision real-time pulse output port. (19 pins)	
PB0/PPO8 to PB7/PPO15	Output/Real-time output	(Port B) 8-bit output port. Data is gated with PPO contents by OR-gate and they are output. (8 pins)		
PC0/PPO16 to PC2/PPO18	I/O/Real-time output	(Port C) 8-bit I/O port. I/O can be set in a unit of single bits. Data is gated with PPO or RTO contents by OR-gate and they are output. (8 pins)		
PC3/RTO3 to PC7/RTO7	I/O/Real-time output		Real-time pulse generator (RTG) output. Functions as high precision real-time pulse output port. (5 pins)	
PD0 to PD7	I/O	(Port D) 8-bit I/O port. I/O can be set in a unit of 4 bits. Can 12mA sink current. (8 pins)		
PE0/ $\overline{\text{INT0}}$	Input/Input	(Port E) 8-bit port. Lower 2 bits are for inputs; upper 6 bits are for outputs. (8 pins)	Input pin to request external interruption. Active when falling edge.	
PE1/ $\overline{\text{EC}}/\overline{\text{INT2}}$	Input/Input/Input		External event input pin for timer/counter.	Input pin to request external interruption. Active when falling edge.
PE2/PWM0	Output/Output		PWM output pins. (2 pins)	
PE3/PWM1	Output/Output			
PE4/DAA0	Output/Output			
PE5/DAA1	Output/Output			
PE6/DAB0	Output/Output			
PE7/DAB1	Output/Output		DA gate pulse output pins. (4 pins)	
AN0 to AN3	Input	Analog input pins to A/D converter. (12 pins)		
PF0/AN4 to PF3/AN7	Input/Input	(Port F) Lower 4 bits are for inputs; upper 4 bits are for outputs. Lower 4 bits also serve as standby release input pin. (8 pins)		
PF4/AN8 to PF7/AN11	Output/Input			
$\overline{\text{SCK0}}$	I/O	Serial clock (CH0) I/O pin.		
SO0	Output	Serial data (CH0) output pin.		
SI0	Input	Serial data (CH0) input pin.		
$\overline{\text{CS0}}$	Input	Serial chip select (CH0) input pin.		

Symbol	I/O	Description	
PG0/CFG	Input/Input	(Port G) 8-bit input port. (8 pins)	Capstan FG input pin.
PG1/DFG	Input/Input		Drum FG input pin.
PG2/DPG	Input/Input		Drum PG input pin.
PG3/PBCTL	Input/Input		Playback CTL pulse input pin.
PG4/SYNC0	Input/Input		Composite sync signal input pin. (2 pins)
PG5/SYNC1	Input/Input		
PG6/EXI0	Input/Input		External input pin to FRC capture unit. (2 pins)
PG7/EXI1	Input/Input		
PH0 to PH7	Output	(Port H) 8-bit output port; N-ch open drain output of medium drive voltage (12V) and large current (12mA). (8 pins)	
PI1/RMC	I/O/Input	(Port I) 7-bit I/O port. I/O port can be set in a unit of single bits. (7 pins)	Remote control receiving circuit input pin.
PI2/PWM	I/O/Output		14-bit PWM output pin.
PI3/TO/ DDO/ADJ	I/O/Output/ Output/Output		Timer/counter, CTL duty detection, 32kHz oscillation adjustment output pin.
PI4/INT1/ NMI	I/O/Input/Input		Input pin to request external interruption and non maskable interruption. Active when falling edge.
PI5/SCK1	I/O/I/O		Serial clock (CH1) I/O pin.
PI6/SO1	I/O/Output		Serial data (CH1) output pin.
PI7/SI1	I/O/Input		Serial data (CH1) input pin.
PJ0 to PJ7	I/O		(Port J) 8-bit I/O port. Function as standby release input can be set in a unit of single bits. I/O can be set in a unit of single bits.
EXTAL	Input	Connecting pin of crystal oscillator for system clock. When supplying the external clock, input the external clock to EXTAL pin and input opposite phase clock to XTAL pin.	
XTAL	Output		
TEX	Input	Connecting pin of crystal oscillator for 32kHz timer clock. When used as event counter, input to TEX pin and leave TX pin open. (Feedback resistor is not removed.)	
TX	Output		
RST	Input	System reset pin of active Low level.	
MP	Input	Test mode input pin. Always connect to GND.	
AVDD		Positive power supply pin of A/D converter.	
AVREF	Input	Reference voltage input pin of A/D converter.	
AVss		GND pin of A/D converter.	
VDD		Positive power supply pin.	
NC		NC pin. Connect this pin to VDD for normal operation.	
Vss		GND pin. Connect both Vss pins to GND.	

Input/Output Circuit Formats for Pins

Pin	Circuit format	When reset
<p>Port A Port B</p> <p>PA0/PPO0 to PA7/PPO7 PB0/PPO8 to PB7/PPO15</p> <p>16 pins</p>	<p>PPO data</p> <p>Ports A and B data</p> <p>Data bus</p> <p>RD (Ports A and B)</p> <p>Output becomes active from high impedance by data writing to port register.</p>	<p>Hi-Z</p>
<p>Port C</p> <p>PC0/PPO16 to PC2/PPO18 PC3/RTO3 to PC7/RTO7</p> <p>8 pins</p>	<p>PPO, RTO data</p> <p>Port C data</p> <p>Port C direction</p> <p>Data bus</p> <p>RD (Port C)</p> <p>Input protection circuit</p> <p>IP</p>	<p>Hi-Z</p>
<p>Port D</p> <p>PD0 to PD7</p> <p>8 pins</p>	<p>Port D data</p> <p>Port D direction</p> <p>Data bus</p> <p>RD (Port D)</p> <p>Large current 12mA</p> <p>IP</p>	<p>Hi-Z</p>

Pin	Circuit format	When reset
PE0/ $\overline{\text{INT0}}$ PE1/ $\overline{\text{EC/INT2}}$ 2 pins		Hi-Z
PE2/PWM0 PE3/PWM1 PE4/DAA0 PE5/DAA1 4 pins		Hi-Z
PE6/DAB0 PE7/DAB1 2 pins		High level
AN0 to AN3 4 pins		Hi-Z
PF0/AN4 to PF3/AN7 4 pins		Hi-Z

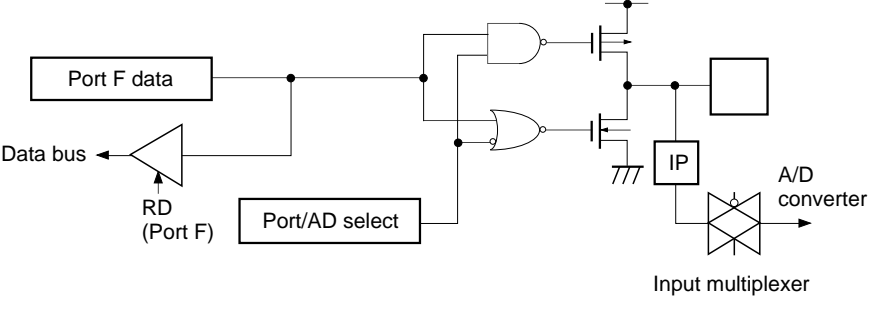
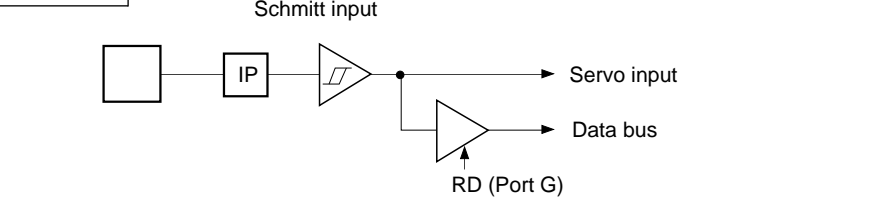
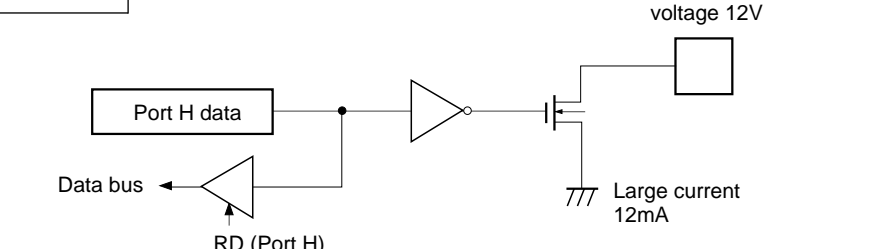
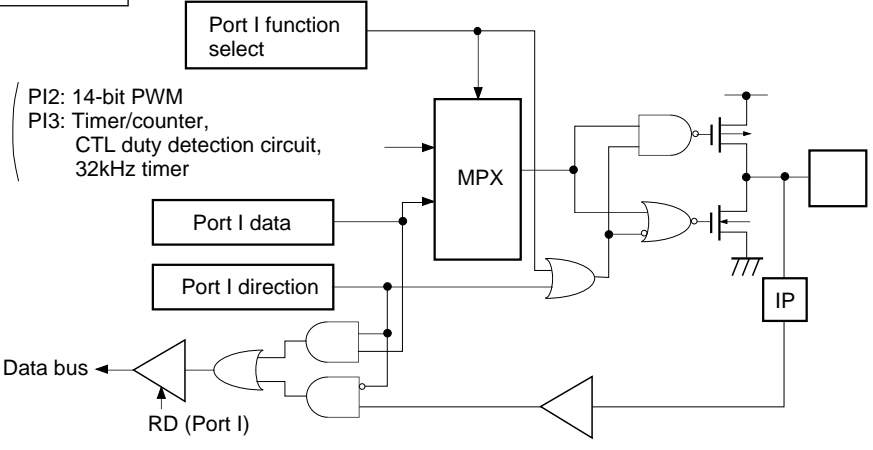
Pin	Circuit format	When reset
<p>PF4/AN8 to PF7/AN11</p> <p>4 pins</p>	<p>Port F</p>  <p>The diagram shows the internal circuit for Port F. It includes a 'Port F data' register connected to a 'Data bus' via a multiplexer. A 'Port/AD select' signal is used to route data to either the data bus or an 'Input multiplexer'. The input multiplexer is connected to an 'IP' (Input Processor) block, which then feeds into an 'A/D converter'.</p>	<p>Hi-Z</p>
<p>PG0/CFG PG1/DFG PG2/DPG PG3/PBCTL PG4/SYNC0 PG5/SYNC1 PG6/EXI0 PG7/EXI1</p> <p>8 pins</p>	<p>Port G</p> <p>Schmitt input</p>  <p>Note) For PG4/SYNC0 and PG5/SYNC1, CMOS schmitt input or TTL schmitt input can be selected with the mask option.</p> <p>The diagram shows Port G configured as a Schmitt input. It features an 'IP' block followed by a Schmitt trigger. The output of the Schmitt trigger can be directed to a 'Servo input' or a 'Data bus'. The 'Data bus' connection is controlled by 'RD (Port G)'.</p>	<p>Hi-Z</p>
<p>PH0 to PH7</p> <p>8 pins</p>	<p>Port H</p>  <p>The diagram shows Port H as a push-pull output. It consists of a 'Port H data' register connected to a 'Data bus' via a multiplexer. The output stage includes a driver transistor that can source or sink a 'Large current 12mA' from a 'Medium drive voltage 12V' supply.</p>	<p>Hi-Z</p>
<p>PI2/PWM PI3/TO/ DDO/ADJ</p> <p>2 pins</p>	<p>Port I</p> <p>Port I function select</p> <p>PI2: 14-bit PWM PI3: Timer/counter, CTL duty detection circuit, 32kHz timer</p>  <p>The diagram shows Port I with a complex internal structure. It includes a 'Port I function select' register that routes signals to an 'MPX' (Multiplexer). The MPX is also influenced by 'Port I data' and 'Port I direction' registers. The output of the MPX is connected to a driver stage with an 'IP' block. The 'Data bus' is connected to the MPX via a multiplexer, controlled by 'RD (Port I)'.</p>	<p>Hi-Z</p>

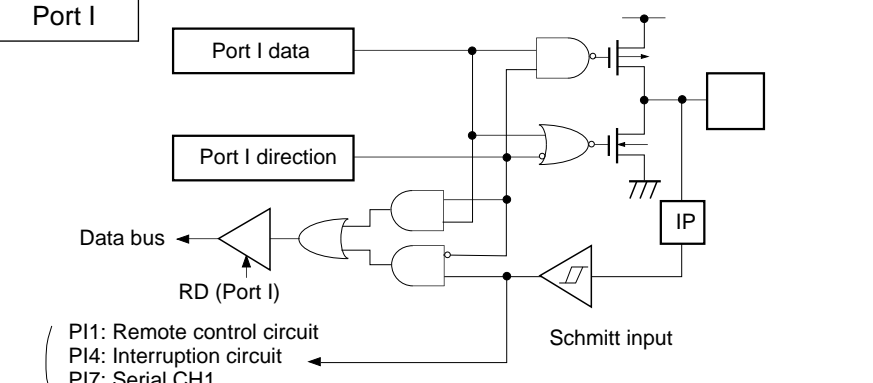
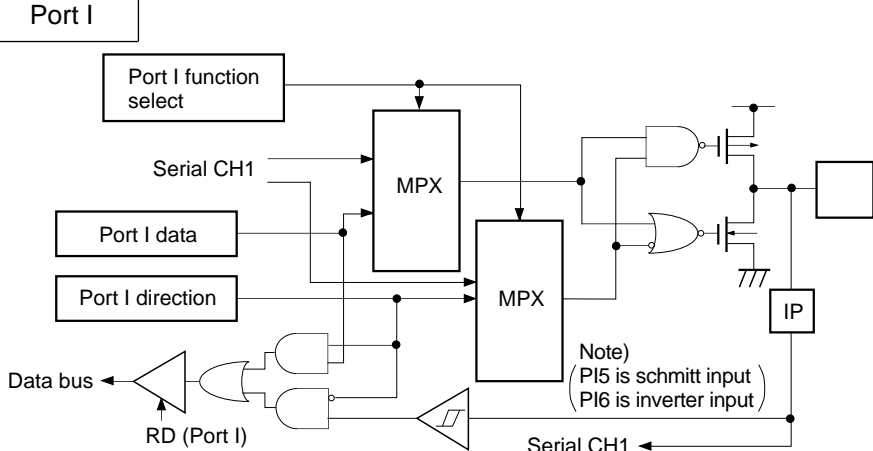
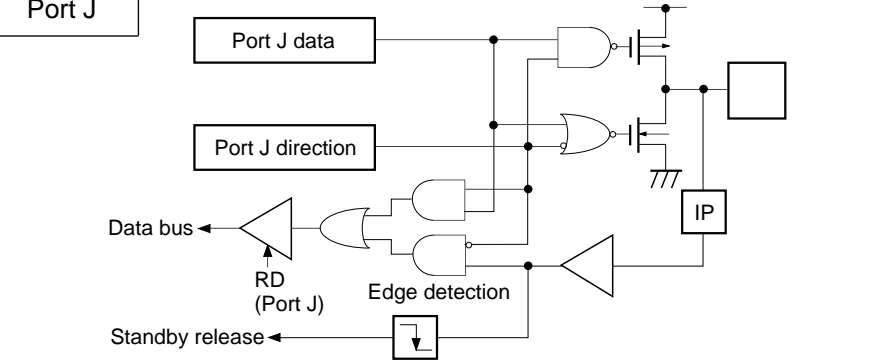
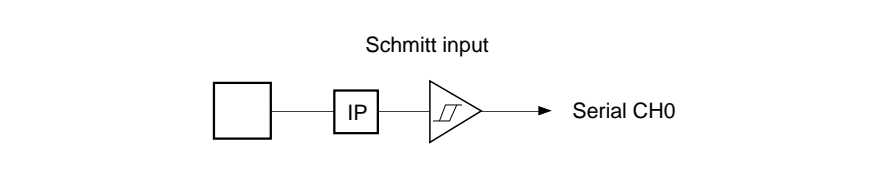
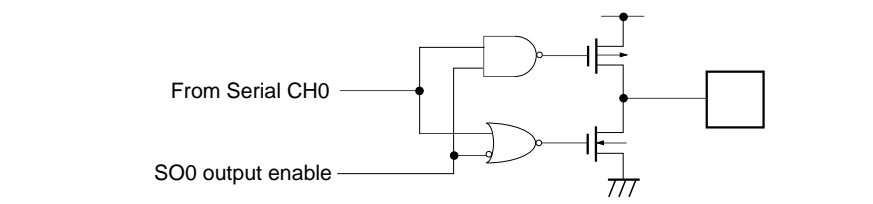
Pin	Circuit format	When reset
<p>PI1/RMC PI4/$\overline{\text{INT1}}$/NMI PI7/SI1</p> <p>3 pins</p>	<p>Port I</p>  <p>Data bus ← RD (Port I)</p> <p>Schmitt input</p> <p>IP</p> <p>(PI1: Remote control circuit PI4: Interruption circuit PI7: Serial CH1</p>	<p>Hi-Z</p>
<p>PI5/$\overline{\text{SCK1}}$ PI6/SO1</p> <p>2 pins</p>	<p>Port I</p>  <p>Port I function select</p> <p>Serial CH1</p> <p>MPX</p> <p>MPX</p> <p>Port I data</p> <p>Port I direction</p> <p>Data bus ← RD (Port I)</p> <p>Serial CH1</p> <p>Note) PI5 is schmitt input PI6 is inverter input</p> <p>IP</p>	<p>Hi-Z</p>
<p>PJ0 to PJ7</p> <p>8 pins</p>	<p>Port J</p>  <p>Port J data</p> <p>Port J direction</p> <p>Data bus ← RD (Port J)</p> <p>Edge detection</p> <p>Standby release</p> <p>IP</p>	<p>Hi-Z</p>
<p>$\overline{\text{CS0}}$ SI0</p> <p>2 pins</p>	<p>Schmitt input</p>  <p>Serial CH0</p>	<p>Hi-Z</p>
<p>SO0</p> <p>1 pin</p>	 <p>From Serial CH0</p> <p>SO0 output enable</p> <p>IP</p>	<p>Hi-Z</p>

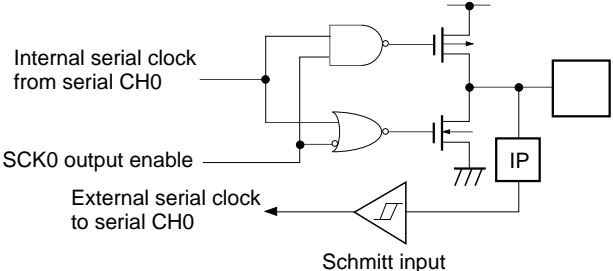
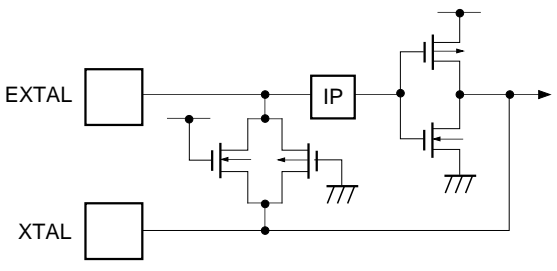
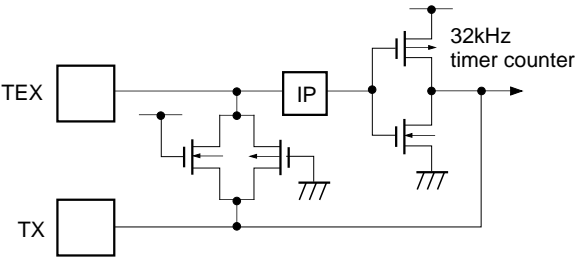
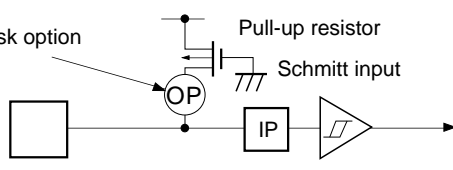
Pin	Circuit format	When reset
<p>$\overline{\text{SCK0}}$</p> <p>1 pin</p>		<p>Hi-Z</p>
<p>EXTAL XTAL</p> <p>2 pins</p>	 <ul style="list-style-type: none"> • Shows the circuit composition during oscillation. • Feedback resistor is removed and XTAL becomes High level during stop. 	<p>Oscillation</p>
<p>TEX TX</p> <p>2 pins</p>	 <ul style="list-style-type: none"> • Shows the circuit composition during oscillation. • Feedback resistor is removed during 32kHz oscillation circuit stop by software. At this time TEX pin outputs Low level and TX pin outputs High level. 	<p>Oscillation</p>
<p>$\overline{\text{RST}}$</p> <p>1 pin</p>		<p>Low level</p>

Absolute Maximum Ratings

(V_{SS} = 0V)

Item	Symbol	Rating	Unit	Remarks
Supply voltage	V _{DD}	-0.3 to +7.0	V	
	AV _{DD}	AV _{SS} to +7.0* ¹	V	
	AV _{SS}	-0.3 to +0.3	V	
Input voltage	V _{IN}	-0.3 to +7.0* ¹	V	
Output voltage	V _{OUT}	-0.3 to +7.0* ¹	V	
Medium drive output voltage	V _{OUTP}	-0.3 to +15.0	V	Port H (PH)
High level output current	I _{OH}	-5	mA	
High level total output current	∑I _{OH}	-50	mA	Total of output pins
Low level output current	I _{OL}	15	mA	Other than large current output port (value per pin)
	I _{OLC}	20	mA	Large current port* ² (value per pin)
Low level total output current	∑I _{OL}	130	mA	Total of output pins
Operating temperature	T _{opr}	-20 to +75	°C	
Storage temperature	T _{stg}	-55 to +150	°C	
Allowable power dissipation	P _D	600	mW	QFP package type
		380		LQFP package type

*¹ AV_{DD}, V_{IN} and V_{OUT} must not exceed V_{DD} + 0.3V.

*² The large current output ports are Port D (PD) and Port H (PH).

Note) Usage exceeding absolute maximum ratings may permanently impair the LSI. Normal operation should better take place under the recommended operating conditions. Exceeding those conditions may adversely affect the reliability of the LSI.

Recommended Operating Conditions

(V_{SS} = 0V)

Item	Symbol	Min.	Max.	Unit	Remarks
Supply voltage	V _{DD}	4.5	5.5	V	Guaranteed operation range for 1/2, 1/4 frequency dividing clock
		3.5	5.5	V	Guaranteed operation range for 1/16 frequency dividing clock or during SLEEP mode.
		2.7	5.5	V	Guaranteed operation range by TEX clock
		2.5	5.5	V	Guaranteed data hold operation range during STOP
Analog power supply	AV _{DD}	4.5	5.5	V	*1
High level input voltage	V _{IH}	0.7V _{DD}	V _{DD}	V	*2
	V _{IHS}	0.8V _{DD}	V _{DD}	V	CMOS schmitt input*3
	V _{IHTS}	2.2	V _{DD}	V	TTL schmitt input*4
	V _{IHEX}	V _{DD} - 0.4	V _{DD} + 0.3	V	EXTAL pin*5 TEX pin*6
Low level input voltage	V _{IL}	0	0.3V _{DD}	V	*2
	V _{ILS}	0	0.2V _{DD}	V	CMOS schmitt input*3
	V _{ILTS}	0	0.8	V	TTL schmitt input*4
	V _{ILEX}	-0.3	0.4	V	EXTAL pin*5 TEX pin*6
Operating temperature	T _{opr}	-20	+75	°C	

*1 AV_{DD} and V_{DD} should be set to the same voltage.

*2 Normal input port (each pin of PC, PD, PE0, PE1, PF0 to PF3, PG, PI and PJ), MP pin.

*3 Each pin of CS0, SI0, SCK0, RST, PE0/INT0, PE1/EC/INT2, PG (For PG4 and PG5, when CMOS schmitt input is selected with mask option), PI1/RMC, PI4/INT1/NMI, PI5/SCK1 and PI7/SI1.

*4 Each pin of PG4 and PG5 (When TTL schmitt input is selected with mask option)

*5 Specifies only during external clock input.

*6 Specifies only during event count clock input.

Electrical Characteristics

DC Characteristics

(Ta = -20 to +75°C, Vss = 0V)

Item	Symbol	Pins	Conditions	Min.	Typ.	Max.	Unit
High level output voltage	V _{OH}	PA to PD, PE2 to PE7, PF4 to PF7, PH (V _{OL} only)	V _{DD} = 4.5V, I _{OH} = -0.5mA	4.0			V
			V _{DD} = 4.5V, I _{OH} = -1.2mA	3.5			V
Low level output voltage	V _{OL}	PI1 to PI7	V _{DD} = 4.5V, I _{OL} = 1.8mA			0.4	V
			V _{DD} = 4.5V, I _{OL} = 3.6mA			0.6	V
		PD, PH	V _{DD} = 4.5V, I _{OL} = 12.0mA			1.5	V
Input current	I _{IHE}	EXTAL	V _{DD} = 5.5V, V _{IH} = 5.5V	0.5		40	μA
	I _{ILE}		V _{DD} = 5.5V, V _{IL} = 0.4V	-0.5		-40	μA
	I _{IHT}	TEX	V _{DD} = 5.5V, V _{IH} = 5.5V	0.1		10	μA
	I _{ILT}		V _{DD} = 5.5V, V _{IL} = 0.4V	-0.1		-10	μA
	I _{ILR}		R _{ST} *1	-1.5		-400	μA
I/O leakage current	I _{Iz}	PA to PG, PI, PJ, MP, AN0 to AN3, CS0, SI0, SO0, SCK0, RST*1	V _{DD} = 5.5V, V _I = 0, 5.5V			±10	μA
Open drain output leakage current (N-CH Tr off state)	I _{LOH}	PH	V _{DD} = 5.5V, V _{OH} = 12V			50	μA
Supply current*2	I _{DD1}	V _{DD}	16MHz crystal oscillation (C ₁ = C ₂ = 15pF), V _{DD} = 5.5V		20	45	mA
	I _{DDS1}		16MHz crystal oscillation (C ₁ = C ₂ = 15pF), V _{DD} = 5.5V, SLEEP mode		1.1	8	mA
	I _{DD2}		32kHz crystal oscillation (C ₁ = C ₂ = 47pF), V _{DD} = 3.3V		35	100	μA
	I _{DDS2}		32kHz crystal oscillation (C ₁ = C ₂ = 47pF), V _{DD} = 3.3V, SLEEP mode		7	30	μA
	I _{DDS3}		V _{DD} = 5.5V, STOP mode (termination of 32kHz and 16MHz crystal oscillation)				10
Input capacity	C _{IN}	PC, PD, PE0 to 1, PF0 to 3, PG, PI, PJ, AN, SCK0, SI0, CS0, EXTAL, XTAL, TEX, TX, RST, MP	Clock 1MHz 0V other than the measured pins		10	20	pF

*1 R_{ST} pin specifies the input current when the pull-up resistor is selected, and specifies leakage current when no resistance is selected.

*2 When entire output pins are open.

*3 When setting upper 2 bits (CPU clock selection) of clock control register (CLC: 00FE_H) to "00" and operating in high speed mode (1/2 frequency dividing clock).

AC Characteristics

(1) Clock timing

(Ta = -20 to +75°C, VDD = 4.5 to 5.5V, VSS = 0V)

Item	Symbol	Pins	Conditions	Min.	Typ.	Max.	Unit
System clock frequency	fc	XTAL EXTAL	Fig. 1, Fig. 2	1		16	MHz
System clock input pulse width	tXL, tXH	XTAL EXTAL	Fig. 1, Fig. 2 (External clock drive)	28			ns
System clock input rise and fall times	tCR, tCF	XTAL EXTAL	Fig. 1, Fig. 2 (External clock drive)			200	ns
Event count clock input pulse width	tEH, tEL	EC	Fig. 3	4tsys*1			ns
Event count clock input rise and fall times	tER, tEF	EC	Fig. 3			20	ns
System clock frequency	fc	TEX TX	Fig. 2 VDD = 2.7 to 5.5V (32kHz clock applied condition)		32.768		kHz
Event count clock input pulse width	tTL, tTH	TEX	Fig. 3	10			μs
Event count clock input rise and fall times	tTR, tTF	TEX	Fig. 3			20	ms

*1 tsys indicates three values according to the contents of the clock control register (CLC; 00FEH) upper 2 bits (CPU clock selection).

tsys [ns] = 2000/fc (Upper 2 bits = "00"), 4000/fc (Upper 2 bits = "01"), 16000/fc (Upper 2 bits = "11")

Fig. 1. Clock timing

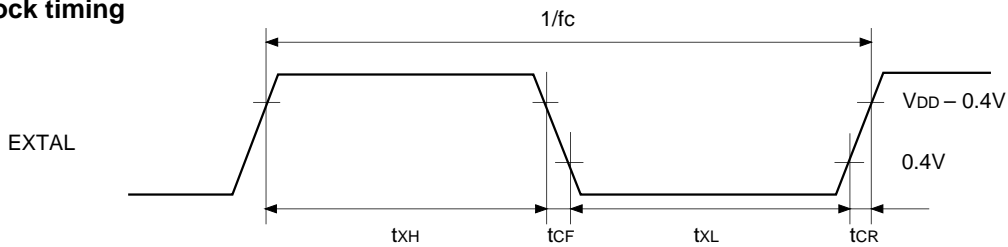

Fig. 2. Clock applied condition

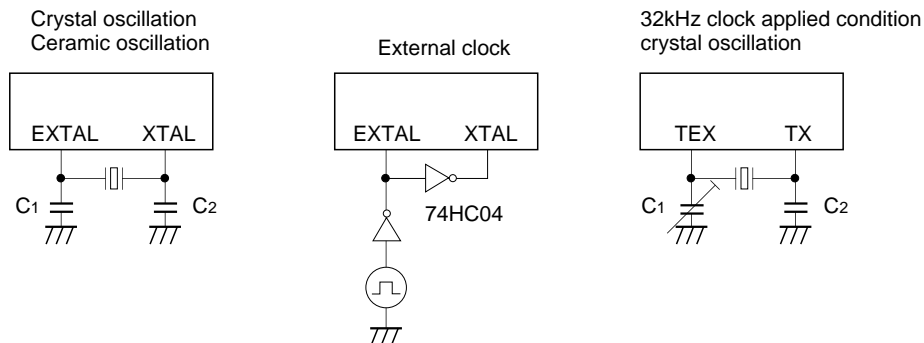
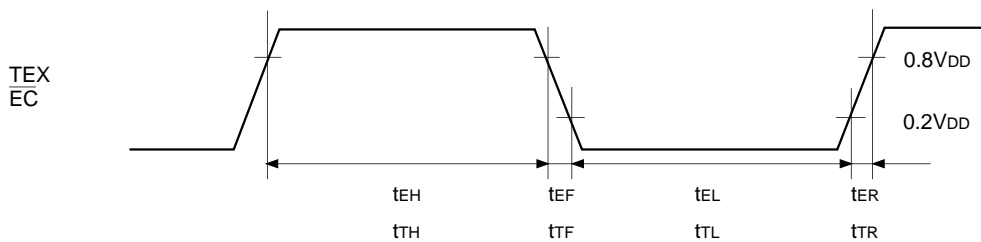

Fig. 3. Event count clock timing



(2) Serial transfer (CH0)

(Ta = -20 to +75°C, VDD = 4.5 to 5.5V, VSS = 0V)

Item	Symbol	Pin	Condition	Min.	Max.	Unit
$\overline{CS0} \downarrow \rightarrow \overline{SCK0}$ delay time	t _{DCSK}	$\overline{SCK0}$	Chip select transfer mode ($\overline{SCK0}$ = output mode)		t _{sys} + 200	ns
$\overline{CS0} \downarrow \rightarrow \overline{SCK0}$ float delay time	t _{DCSKF}	$\overline{SCK0}$	Chip select transfer mode ($\overline{SCK0}$ = output mode)		t _{sys} + 200	ns
$\overline{CS0} \downarrow \rightarrow \overline{SO0}$ delay time	t _{DCSO}	SO0	Chip select transfer mode		t _{sys} + 200	ns
$\overline{CS0} \downarrow \rightarrow \overline{SO0}$ float delay time	t _{DCSOF}	SO0	Chip select transfer mode		t _{sys} + 200	ns
$\overline{CS0}$ High level width	t _{WHCS}	$\overline{CS0}$	Chip select transfer mode	t _{sys} + 200		ns
$\overline{SCK0}$ cycle time	t _{KCY}	$\overline{SCK0}$	Input mode	2t _{sys} + 200		ns
			Output mode	16000/fc		ns
$\overline{SCK0}$ High and Low level widths	t _{KH} t _{KL}	$\overline{SCK0}$	Input mode	t _{sys} + 100		ns
			Output mode	8000/fc - 50		ns
SI0 input setup time (for $\overline{SCK0} \uparrow$)	t _{SIK}	SI0	$\overline{SCK0}$ input mode	100		ns
			$\overline{SCK0}$ output mode	200		ns
SI0 input hold time (for $\overline{SCK0} \uparrow$)	t _{KSI}	SI0	$\overline{SCK0}$ input mode	t _{sys} + 200		ns
			$\overline{SCK0}$ output mode	100		ns
$\overline{SCK0} \downarrow \rightarrow \overline{SO0}$ delay time	t _{KSO}	SO0	$\overline{SCK0}$ input mode		t _{sys} + 200	ns
			$\overline{SCK0}$ output mode		100	ns

Note 1) t_{sys} indicates three values according to the contents of the clock control register (CLC; 00FEH) upper 2 bits (CPU clock selection).

t_{sys} [ns] = 2000/fc (Upper 2 bits = "00"), 4000/fc (Upper 2 bits = "01"), 16000/fc (Upper 2 bits = "11")

Note 2) The load of $\overline{SCK0}$ output mode and SO0 output delay time is 50pF + 1TTL.

Fig. 4. Serial transfer timing (CH0)

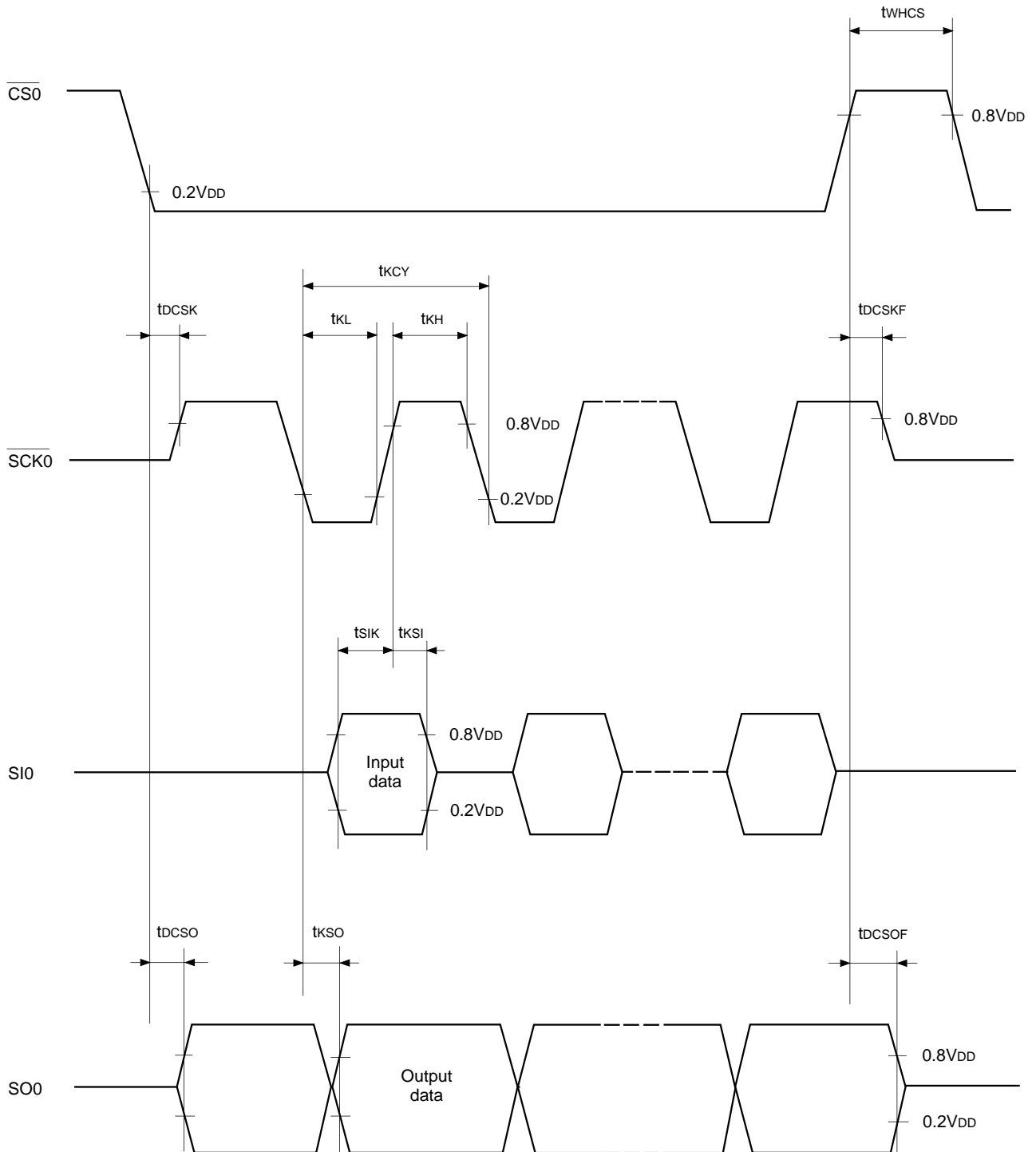

Serial transfer (CH1)

($T_a = -20$ to $+75^\circ\text{C}$, $V_{DD} = 4.5$ to 5.5V , $V_{SS} = 0\text{V}$)

Item	Symbol	Pins	Conditions	Min.	Max.	Unit
$\overline{\text{SCK1}}$ cycle time	t_{KCY}	$\overline{\text{SCK1}}$	Input mode	1000		ns
			Output mode	$16000/f_c$		ns
$\overline{\text{SCK1}}$ High and Low level widths	t_{KH} t_{KL}	$\overline{\text{SCK1}}$	Input mode	400		ns
			Output mode	$8000/f_c - 50$		ns
SI1 input setup time (for $\overline{\text{SCK1}} \uparrow$)	t_{SIK}	SI1	$\overline{\text{SCK1}}$ input mode	100		ns
			$\overline{\text{SCK1}}$ output mode	200		ns
SI1 input hold time (for $\overline{\text{SCK1}} \uparrow$)	t_{KSI}	SI1	$\overline{\text{SCK1}}$ input mode	200		ns
			$\overline{\text{SCK1}}$ output mode	100		ns
$\overline{\text{SCK1}} \downarrow \rightarrow \text{SO1}$ delay time	t_{KSO}	SO1	$\overline{\text{SCK1}}$ input mode		200	ns
			$\overline{\text{SCK1}}$ output mode		100	ns

Note) The load of $\overline{\text{SCK1}}$ output mode and SO1 output delay time is $50\text{pF} + 1\text{TTL}$.

Fig. 5. Serial transfer timing (CH1)

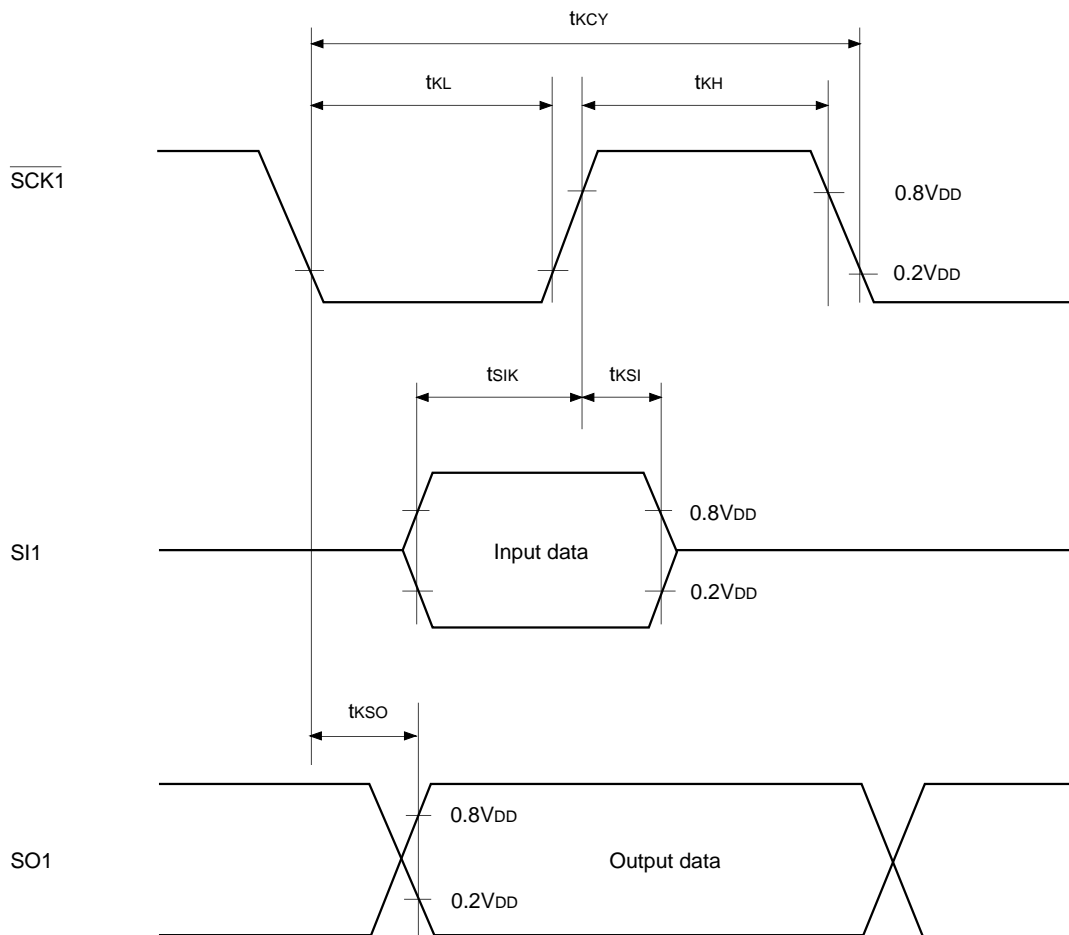

(3) A/D converter characteristics

($T_a = -20$ to $+75^\circ\text{C}$, $V_{DD} = AV_{DD} = 4.5$ to 5.5V , $AV_{REF} = 4.0$ to AV_{DD} , $V_{SS} = AV_{SS} = 0\text{V}$)

Item	Symbol	Pins	Conditions	Min.	Typ.	Max.	Unit
Resolution						8	Bits
Linearity error			$T_a = 25^\circ\text{C}$ $V_{DD} = AV_{DD} = AV_{REF} = 5.0\text{V}$ $V_{SS} = AV_{SS} = 0\text{V}$			± 1	LSB
Absolute error						± 2	LSB
Conversion time	t_{CONV}			$160/f_{ADC}^{*1}$			μs
Sampling time	t_{SAMP}			$12/f_{ADC}^{*1}$			μs
Reference input voltage	V_{REF}	AV_{REF}		$AV_{DD} - 0.5$		AV_{DD}	V
Analog input voltage	V_{IAN}	AN0 to AN11		0		AV_{REF}	V
AVREF current	I_{REF}	AV_{REF}	Operating mode		0.6	1.0	mA
	I_{REFS}		SLEEP mode STOP mode 32kHz operating mode			10	μA

Fig. 6. Definitions of A/D converter terms

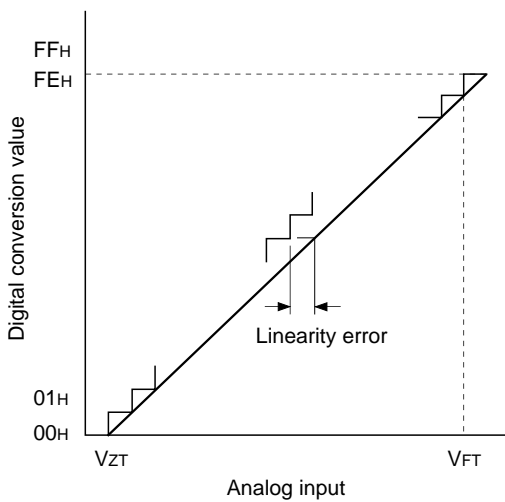

*1 f_{ADC} indicates the below values due to the contents of bit 0 (ADCCCK) of the ADC operation clock selection (MSC: 01FFH), bits 7 (PCK1) and 6 (PCK0) of the clock control register.

ADCCCK PCK1, PCK0	0 ($\phi/2$ selection)	1 (ϕ selection)
	00 ($\phi = f_{EX}/2$)	$f_{ADC} = f_c/2$
01 ($\phi = f_{EX}/4$)	$f_{ADC} = f_c/4$	$f_{ADC} = f_c/2$
11 ($\phi = f_{EX}/16$)	$f_{ADC} = f_c/16$	$f_{ADC} = f_c/8$

(4) Interruption, reset input

(Ta = -20 to +75°C, VDD = 4.5 to 5.5V, VSS = 0V)

Item	Symbol	Pins	Conditions	Min.	Max.	Unit
External interruption High and Low level widths	t _{IH} t _{IL}	$\overline{\text{INT0}}$ $\overline{\text{INT1}}$ $\overline{\text{INT2}}$ NMI PJ0 to PJ7		1		μs
Reset input Low level width	t _{RSL}	$\overline{\text{RST}}$		32/fc		μs

Fig. 7. Interruption input timing

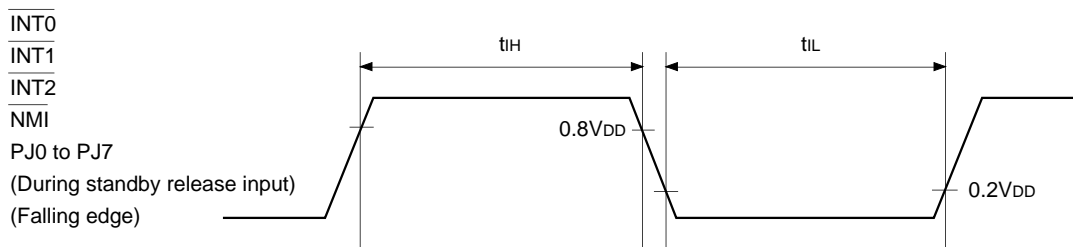
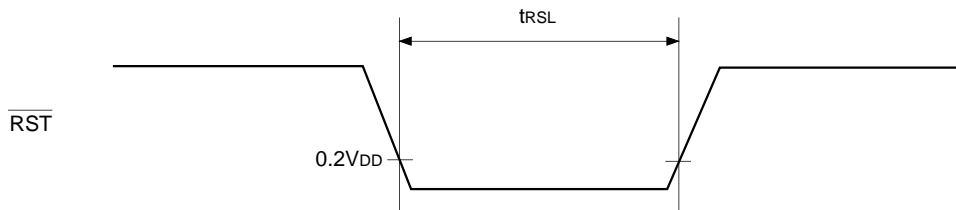

Fig. 8. Reset input timing



(5) Others

(Ta = -20 to +75°C, VDD = 4.5 to 5.5V, VSS = 0V)

Item	Symbol	Pins	Conditions	Min.	Max.	Unit
CFG input High and Low level widths	t _{CFH} t _{CFL}	CFG		t _{FRC} × 24 + 200		ns
DFG input High and Low level widths	t _{DFH} t _{DFL}	DFG		t _{FRC} × 8 + 200		ns
DPG minimum pulse width	t _{DPW}	DPG		50		ns
DPG minimum removal time	t _{rem}	DPG		50		ns
PBCTL input High and Low level widths	t _{CTH} t _{CTL}	$\overline{\text{PBCTL}}$	t _{sys} = 2000/fc	t _{FRC} × 8 + 200 + t _{sys}		ns
EXI input High and Low level widths	t _{EIH} t _{EIL}	EXI0 EXI1	t _{sys} = 2000/fc	t _{FRC} × 8 + 200 + t _{sys}		ns

Note t_{sys} indicates three values according to the contents of the clock control register (CLC; 00FEH) upper 2 bits (CPU clock selection).

t_{sys} [ns] = 2000/fc (Upper 2 bits = "00"), 4000/fc (Upper 2 bits = "01"), 16000/fc (Upper 2 bits = "11")

t_{FRC} [ns] = 1000/fc

Fig. 9. Other timings

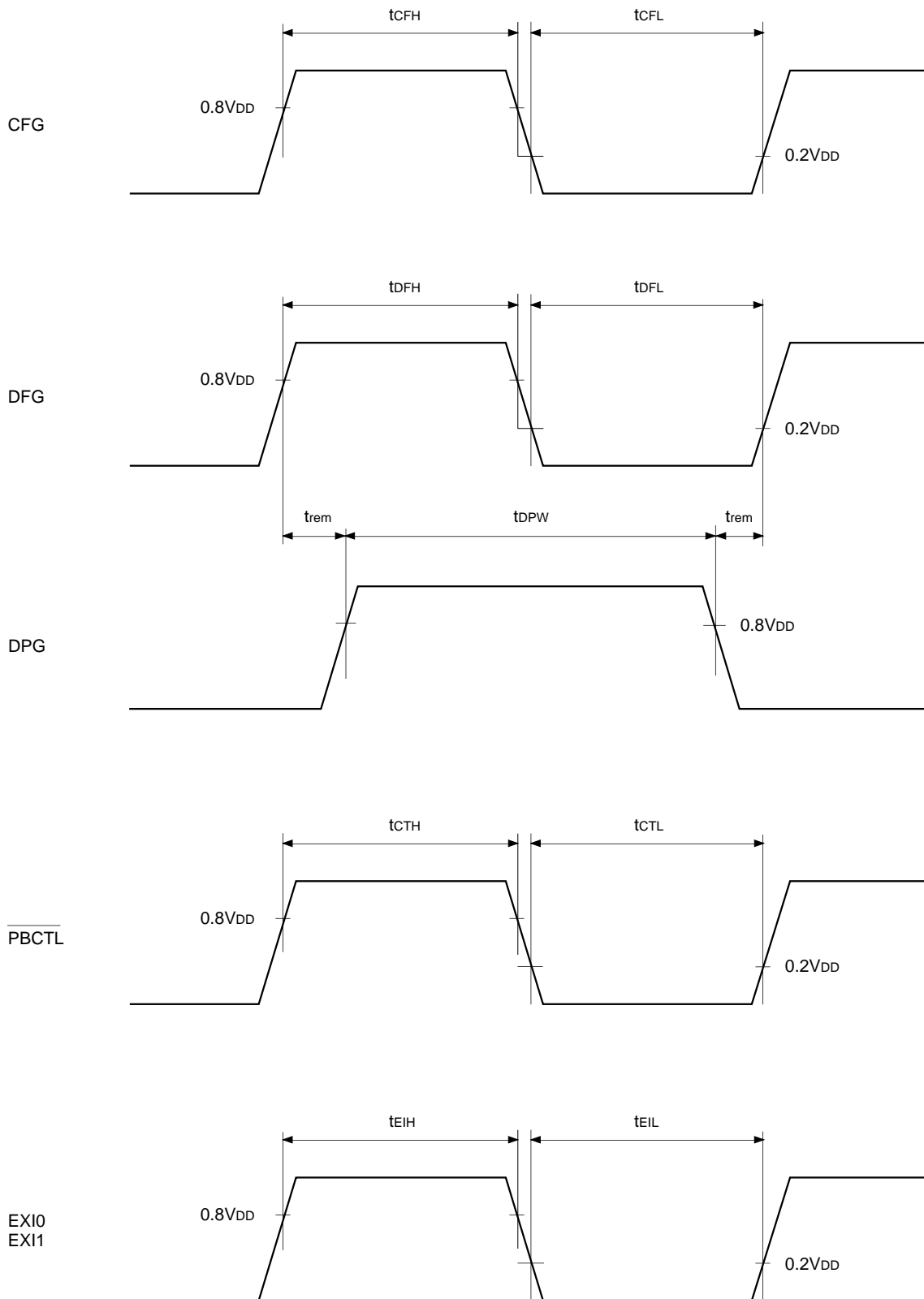

Appendix

Fig. 10. Recommended oscillation circuit

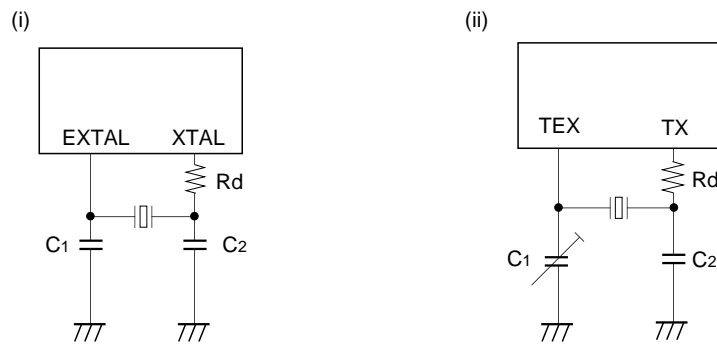

Manufacturer	Model	fc (MHz)	C ₁ (pF)	C ₂ (pF)	Rd (Ω)	Circuit example
RIVER ELETEC CO., LTD.	HC-49/U03	8.00	10	10	0	(i)
		10.00				
		12.00	5	5		
		16.00				
KINSEKI LTD.	HC-49/U (-S)	8.00	16	12	0	(i)
		10.00	16	12		
		12.00	12	12		
		16.00	12	12		
	P3	32.768kHz	30	18	470k	(ii)

Mask option table

Item	Content	
	Reset pin pull-up resistor	Non-existent
Input circuit format* ¹	C-MOS schmitt	TTL schmitt

*¹ The input circuit format can be selected for PG4/SYNC0 pin and PG5/SYNC1, respectively.

Characteristics Curve

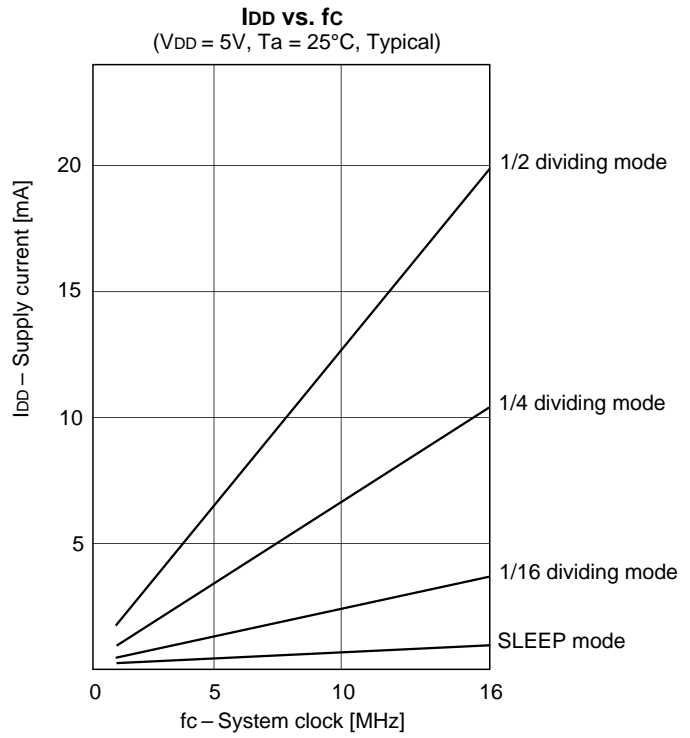
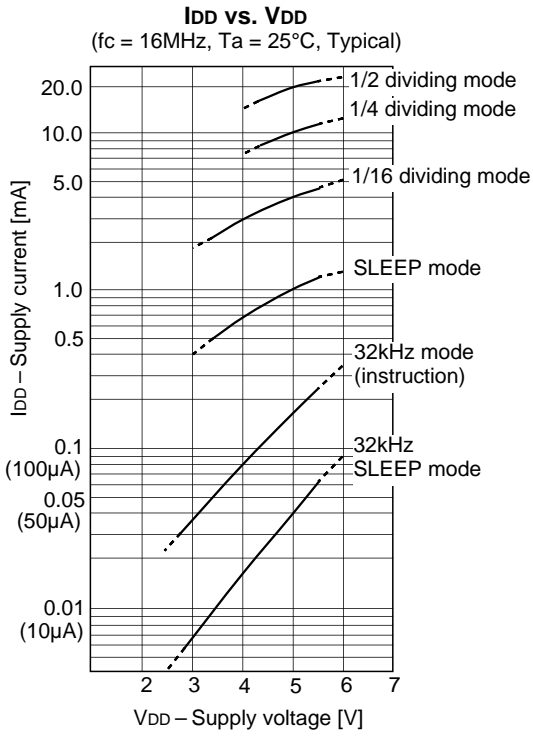

Package Outline

Unit: mm

100PIN QFP (PLASTIC)

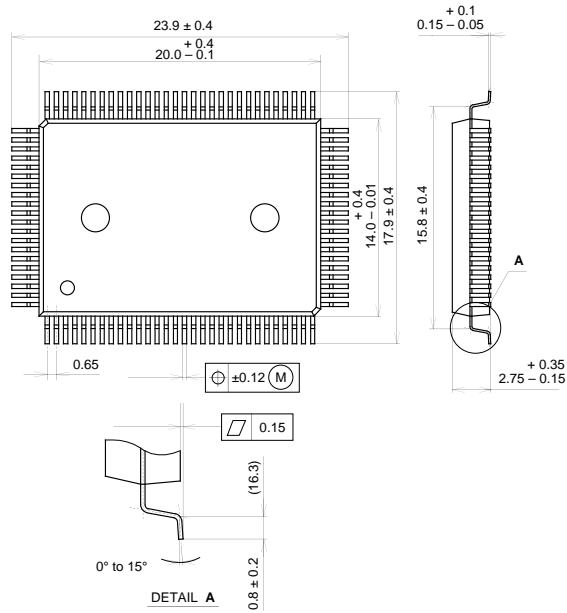

PACKAGE STRUCTURE

SONY CODE	QFP-100P-L01
EIAJ CODE	*QFP100-P-1420-A
JEDEC CODE	_____

PACKAGE MATERIAL	EPOXY RESIN
LEAD TREATMENT	SOLDER PLATING
LEAD MATERIAL	COPPER / 42 ALLOY
PACKAGE WEIGHT	1.4g

100PIN LQFP (PLASTIC)

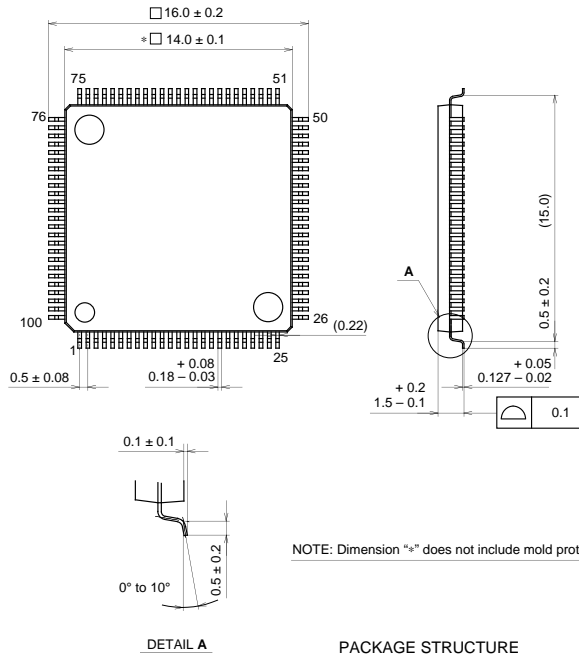

NOTE: Dimension "*" does not include mold protrusion.

PACKAGE STRUCTURE

SONY CODE	LQFP-100P-L01
EIAJ CODE	*QFP100-P-1414-A
JEDEC CODE	_____

PACKAGE MATERIAL	EPOXY/PHENOL RESIN
LEAD TREATMENT	SOLDER PLATING
LEAD MATERIAL	42 ALLOY
PACKAGE WEIGHT	_____



LittleDiode supplies new, hard to find or obsolete electronic components and semiconductors all over the world.

With over two million different components listed you are sure to find the part you need.

Feel free to visit us today at our online store:

LittleDiode.com

Looking forward to providing you with the best possible service.