

Selective Delay Line for LCD

Description

The CXD3504R is a selective delay line IC for performing signal processing during dot and line inverted drive of liquid crystal panels for Sony projectors.

This chip has three built-in 10-bit \times 1200-word 1H delay lines, and data path with or without a 1H delay can be selected by the control pins.

Features

- Supports dot and line inverted drive of liquid crystal panels for Sony projectors
- Three built-in 10-bit \times 1200-word 1H delay lines
- Data path with or without a 1H delay can be selected by the control pins.

Applications

LCD projectors, etc.

Structure

Silicon gate CMOS IC

176 pin LQFP (Plastic)

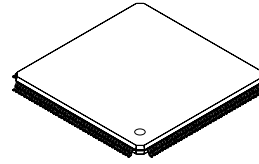

Absolute Maximum Ratings (V_{SS} = 0V)

- | | | | |
|-------------------------------|-------------------|------------------------------------|----|
| • Supply voltage | V _{DD} | -0.3 to +4.6 | V |
| • Input voltage | V _I | -0.3 to V _{DD} + 0.3 | V |
| • Output voltage | V _O | -0.3 to V _{DD} + 0.3 | V |
| • Operating temperature | T _{opr} | -30 to +75 | °C |
| • Storage temperature | T _{stg} | -55 to +125 | °C |
| • Allowable power dissipation | | | |
| | P _{Dmax} | 850mW (T _a \leq 75°C) | |

Recommended Operating Conditions

- | | | | |
|-------------------------|------------------|----------------------|----|
| • Supply voltage | V _{DD} | 3.0 to 3.6 | V |
| • Operating temperature | T _{opr} | -30 to +75 | °C |
| • Input voltage | V _{IN} | 0 to V _{DD} | V |

Sony reserves the right to change products and specifications without prior notice. This information does not convey any license by any implication or otherwise under any patents or other right. Application circuits shown, if any, are typical examples illustrating the operation of the devices. Sony cannot assume responsibility for any problems arising out of the use of these circuits.

Block Diagram

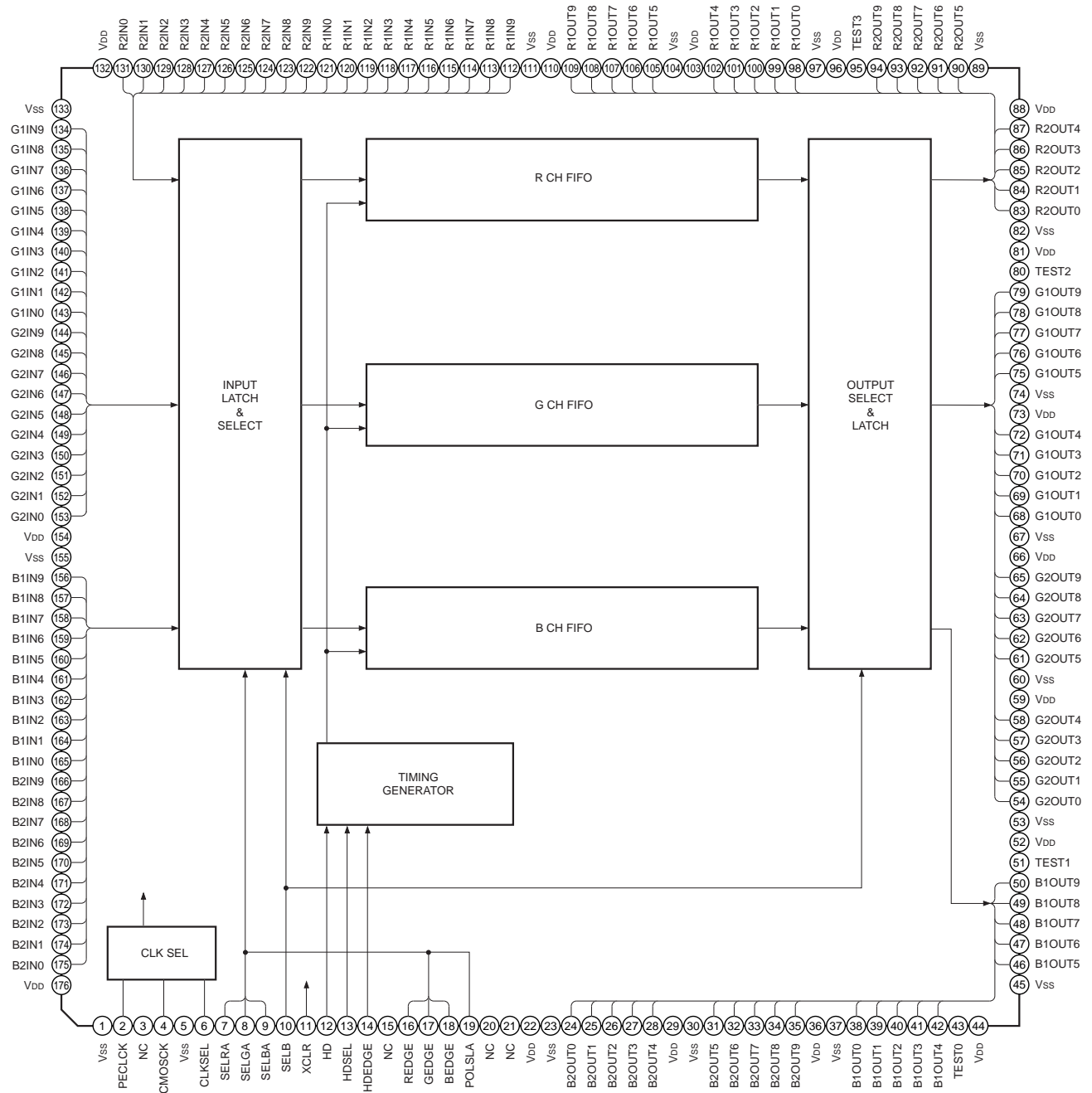

Pin Configuration

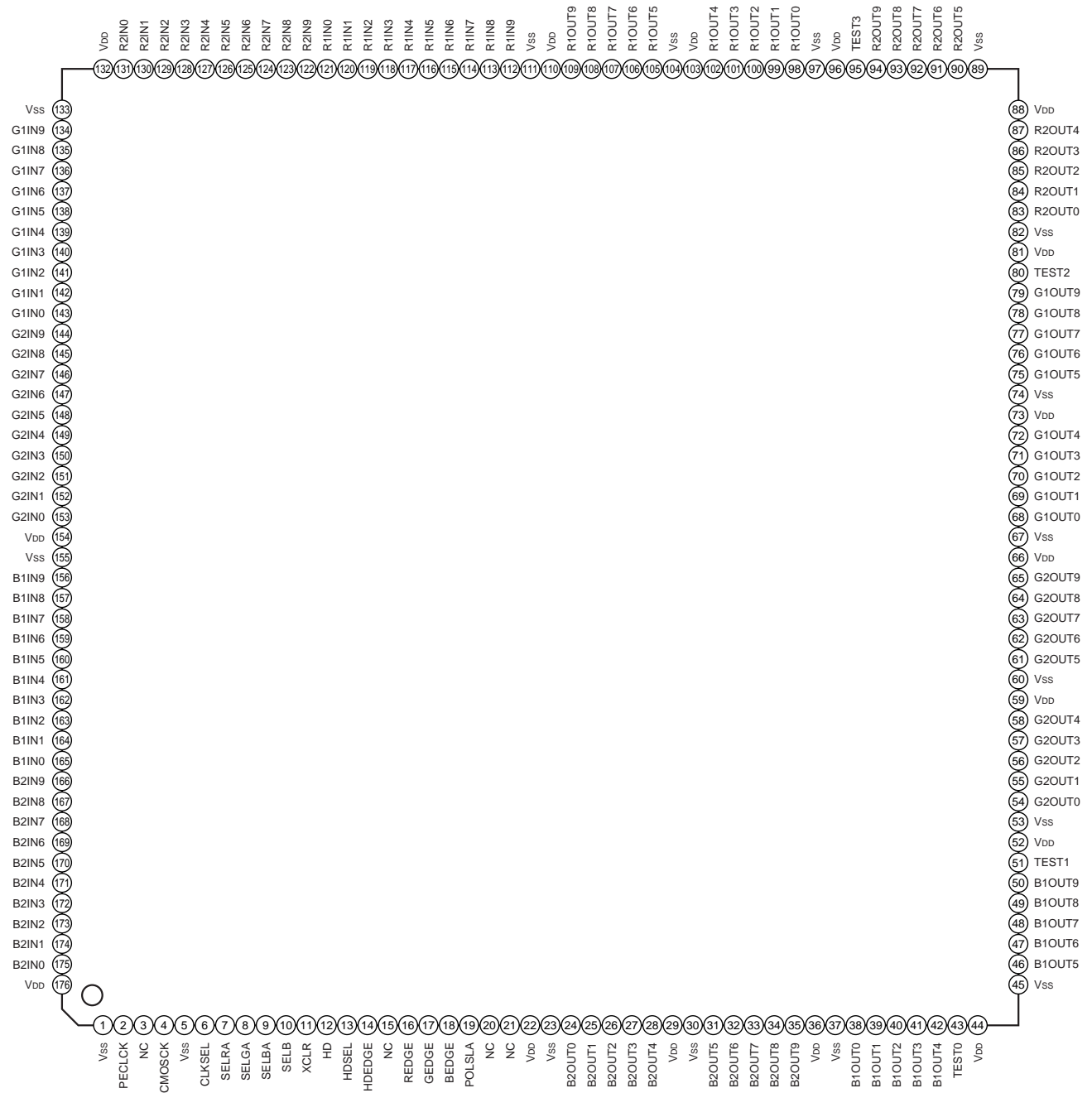

Pin Description

Pin No.	Symbol	I/O	Description	Input pin for open status
1	V _{SS}	P	GND	
2	PECLCK	I	Very little amp. clock input*1	
3	NC			
4	CMOSCK	I	CMOS clock input*2	
5	V _{SS}	P	GND	
6	CLKSEL	I	0: PECL, 1: CMOS	L
7	SELRA	I	SELA (Data path selection A) for R	L
8	SELGA	I	SELA (Data path selection A) for G	L
9	SELBA	I	SELA (Data path selection A) for B	L
10	SELB	I	Data path selection B	L
11	XCLR	I	0: Direct Reset	H
12	HD	I	Horizontal sync signal input	
13	HDSEL	I	HD selection (0: ↓, 1: ↑)	L
14	HDEDGE	I	CK trigger selection of HD (0: ↓, 1: ↑)	L
15	NC		Reserve	
16	REDGE	I	CK trigger selection of R (0: ↓, 1: ↑)	L
17	GEDGE	I	CK trigger selection of G (0: ↓, 1: ↑)	L
18	BEDGE	I	CK trigger selection of B (0: ↓, 1: ↑)	L
19	POLSLA	I	SELA polarity selection	L
20	NC			
21	NC			
22	V _{DD}	P	Power supply	
23	V _{SS}	P	GND	
24	B2OUT0	O	B2 output	
25	B2OUT1	O	B2 output	
26	B2OUT2	O	B2 output	
27	B2OUT3	O	B2 output	
28	B2OUT4	O	B2 output	
29	V _{DD}	P	Power Supply	
30	V _{SS}	P	GND	
31	B2OUT5	O	B2 output	
32	B2OUT6	O	B2 output	
33	B2OUT7	O	B2 output	

*1 Connect to GND or V_{DD} when using CMOS clock.

*2 Connect to GND or V_{DD} when using small amplitude clock.

Pin No.	Symbol	I/O	Description	Input pin for open status
34	B2OUT8	O	B2 output	
35	B2OUT9	O	B2 output	
36	V _{DD}	P	Power supply	
37	V _{SS}	P	GND	
38	B1OUT0	O	B1 output	
39	B1OUT1	O	B1 output	
40	B1OUT2	O	B1 output	
41	B1OUT3	O	B1 output	
42	B1OUT4	O	B1 output	
43	TEST0	I	1: Test mode	L
44	V _{DD}	P	Power supply	
45	V _{SS}	P	GND	
46	B1OUT5	O	B1 output	
47	B1OUT6	O	B1 output	
48	B1OUT7	O	B1 output	
49	B1OUT8	O	B1 output	
50	B1OUT9	O	B1 output	
51	TEST1	I	1: Test mode	L
52	V _{DD}	P	Power supply	
53	V _{SS}	P	GND	
54	G2OUT0	O	G2 output	
55	G2OUT1	O	G2 output	
56	G2OUT2	O	G2 output	
57	G2OUT3	O	G2 output	
58	G2OUT4	O	G2 output	
59	V _{DD}	P	Power supply	
60	V _{SS}	P	GND	
61	G2OUT5	O	G2 output	
62	G2OUT6	O	G2 output	
63	G2OUT7	O	G2 output	
64	G2OUT8	O	G2 output	
65	G2OUT9	O	G2 output	
66	V _{DD}	P	Power supply	
67	V _{SS}	P	GND	
68	G1OUT0	O	G1 output	

Pin No.	Symbol	I/O	Description	Input pin for open status
69	G1OUT1	O	G1 output	
70	G1OUT2	O	G1 output	
71	G1OUT3	O	G1 output	
72	G1OUT4	O	G1 output	
73	V _{DD}	P	Power supply	
74	V _{SS}	P	GND	
75	G1OUT5	O	G1 output	
76	G1OUT6	O	G1 output	
77	G1OUT7	O	G1 output	
78	G1OUT8	O	G1 output	
79	G1OUT9	O	G1 output	
80	TEST2	I	1: Test mode	L
81	V _{DD}	P	Power supply	
82	V _{SS}	P	GND	
83	R2OUT0	O	R2 output	
84	R2OUT1	O	R2 output	
85	R2OUT2	O	R2 output	
86	R2OUT3	O	R2 output	
87	R2OUT4	O	R2 output	
88	V _{DD}	P	Power supply	
89	V _{SS}	P	GND	
90	R2OUT5	O	R2 output	
91	R2OUT6	O	R2 output	
92	R2OUT7	O	R2 output	
93	R2OUT8	O	R2 output	
94	R2OUT9	O	R2 output	
95	TEST3	I	1: Test mode	L
96	V _{DD}	P	Power supply	
97	V _{SS}	P	GND	
98	R1OUT0	O	R1 output	
99	R1OUT1	O	R1 output	
100	R1OUT2	O	R1 output	
101	R1OUT3	O	R1 output	
102	R1OUT4	O	R1 output	
103	V _{DD}	P	Power supply	
104	V _{SS}	P	GND	

Pin No.	Symbol	I/O	Description	Input pin for open status
105	R1OUT5	O	R1 output	
106	R1OUT6	O	R1 output	
107	R1OUT7	O	R1 output	
108	R1OUT8	O	R1 output	
109	R1OUT9	O	R1 output	
110	V _{DD}	P	Power supply	
111	V _{SS}	P	GND	
112	R1IN9	I	R1 input	
113	R1IN8	I	R1 input	
114	R1IN7	I	R1 input	
115	R1IN6	I	R1 input	
116	R1IN5	I	R1 input	
117	R1IN4	I	R1 input	
118	R1IN3	I	R1 input	
119	R1IN2	I	R1 input	
120	R1IN1	I	R1 input	
121	R1IN0	I	R1 input	
122	R2IN9	I	R2 input	
123	R2IN8	I	R2 input	
124	R2IN7	I	R2 input	
125	R2IN6	I	R2 input	
126	R2IN5	I	R2 input	
127	R2IN4	I	R2 input	
128	R2IN3	I	R2 input	
129	R2IN2	I	R2 input	
130	R2IN1	I	R2 input	
131	R2IN0	I	R2 input	
132	V _{DD}	P	Power supply	
133	V _{SS}	P	GND	
134	G1IN9	I	G1 input	
135	G1IN8	I	G1 input	
136	G1IN7	I	G1 input	
137	G1IN6	I	G1 input	
138	G1IN5	I	G1 input	
139	G1IN4	I	G1 input	
140	G1IN3	I	G1 input	

Pin No.	Symbol	I/O	Description	Input pin for open status
141	G1IN2	I	G1 input	
142	G1IN1	I	G1 input	
143	G1IN0	I	G1 input	
144	G2IN9	I	G2 input	
145	G2IN8	I	G2 input	
146	G2IN7	I	G2 input	
147	G2IN6	I	G2 input	
148	G2IN5	I	G2 input	
149	G2IN4	I	G2 input	
150	G2IN3	I	G2 input	
151	G2IN2	I	G2 input	
152	G2IN1	I	G2 input	
153	G2IN0	I	G2 input	
154	V _{DD}	P	Power supply	
155	V _{SS}	P	GND	
156	B1IN9	I	B1 input	
157	B1IN8	I	B1 input	
158	B1IN7	I	B1 input	
159	B1IN6	I	B1 input	
160	B1IN5	I	B1 input	
161	B1IN4	I	B1 input	
162	B1IN3	I	B1 input	
163	B1IN2	I	B1 input	
164	B1IN1	I	B1 input	
165	B1IN0	I	B1 input	
166	B2IN9	I	B2 input	
167	B2IN8	I	B2 input	
168	B2IN7	I	B2 input	
169	B2IN6	I	B2 input	
170	B2IN5	I	B2 input	
171	B2IN4	I	B2 input	
172	B2IN3	I	B2 input	
173	B2IN2	I	B2 input	
174	B2IN1	I	B2 input	
175	B2IN0	I	B2 input	
176	V _{DD}	P	Power supply	

Electrical Characteristics (Input/Output level/ V_{DD} = 3.0 to 3.6V, V_{SS} = 0V, T_a = -30 to +75°C)

Item	Symbol	Conditions	Min.	Typ.	Max.	Unit	Applicable pins
High level input voltage	V_{IH}	CMOS input	$0.7V_{DD}$	—	—	V	*1, *2, *3
Low level input voltage	V_{IL}		—	—	$0.2V_{DD}$	V	
High level output voltage	V_{OH}	$I_{OH} = -12\text{mA}$	$V_{DD} - 0.8$	—	—	V	*4
Low level output voltage	V_{OL}	$I_{OL} = 12\text{mA}$	—	—	0.4	V	
Input leak current	I_{IL}	$V_i = V_{SS}, V_{DD}$	-10	—	10	μA	*1, *2, *3
Pull-up resistor	R_{UP}		80	160	320	$\text{k}\Omega$	*2
Pull-down resistor	R_{DN}		90	180	360	$\text{k}\Omega$	*3

*1 Input pins except PECLCK

*2 XCLR

*3 CLKSEL, SELRA, SELGA, SELBA, SELB, HDSEL, HDEDGE, REDGE, GEDGE, BEDGE, POLSLA

*4 All output pins

AC Characteristics

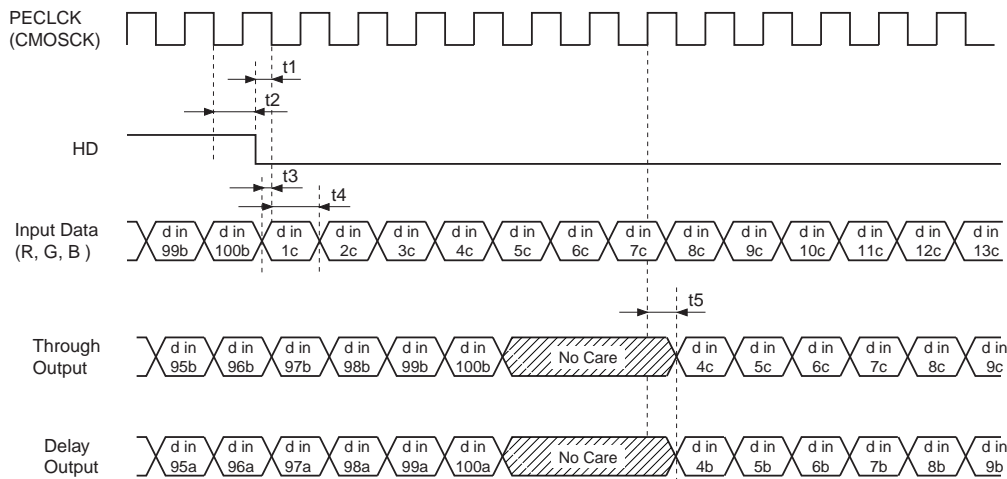

Item	Symbol	Min.	Max.	Unit
Input frequency	f	—	80	MHz
HD set-up time to PECLCK bar	t1	1.5	—	ns
HD hold time from PECLCK bar	t2	4.5	—	ns
R, G, B input data set-up time to PECLCK bar	t3	1	—	ns
R, G, B input data hold time from PECLCK bar	t4	6.5	—	ns
R, G, B output data delay from PECLCK	t5	4	13	ns
HD set-up time to CMOSCK bar	t1	2	—	ns
HD hold time from CMOSCK bar	t2	3	—	ns
R, G, B input data set-up time to CMOSCK bar	t3	1.5	—	ns
R, G, B input data hold time from CMOSCK bar	t4	4.5	—	ns
R, G, B output data delay from CMOSCK	t5	3	12	ns

Note: The above timing values are for PECLCK (CMOSCK) = 80MHz and an output pin capacitance of 20pF.

Description of Operation

1) The following describes only R, but the operation for G and B is the same.

SELRA:SELB = 0:0	R2IN → through → R1OUT
	R1IN → delay → R2OUT
SELRA:SELB = 0:1	R2IN → delay → R1OUT
	R1IN → through → R2OUT
SELRA:SELB = 1:0	R1IN → through → R1OUT
	R2IN → delay → R2OUT
SELRA:SELB = 1:1	R1IN → delay → R1OUT
	R2IN → through → R2OUT

However, POLSLA = 0

2) Be sure to set XCLR to "0" for a clock or more while HD is "1". (when HDSEL = 0) Also, input the HD signal with a "0" period length of 6 clocks or more.

Very Little Signal Amplifier ($V_{DD} = 3.0$ to $3.6V$, $V_{SS} = 0V$, $T_a = -30$ to $+75^{\circ}C$)

Item	Symbol	Min.	Typ.	Max.	Unit
High level input voltage	V_{IH}	0.4	—	3.6	V
Low level input voltage	V_{IL}	0	—	3.2	V
Input frequency	f	—	—	80	MHz
Input amplitude*1	V_{pp}	0.4	—	—	V

Applicable pins: PECLCK (Pin 2)

*1 Input the signal through a capacitor. Also, this amplitude is the value between the through capacitor and the input pin.

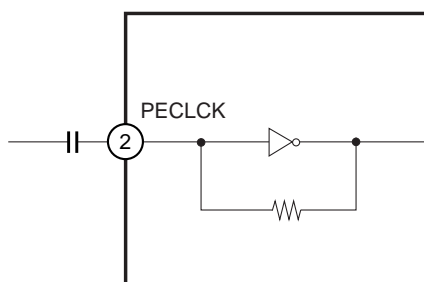

Application Circuit

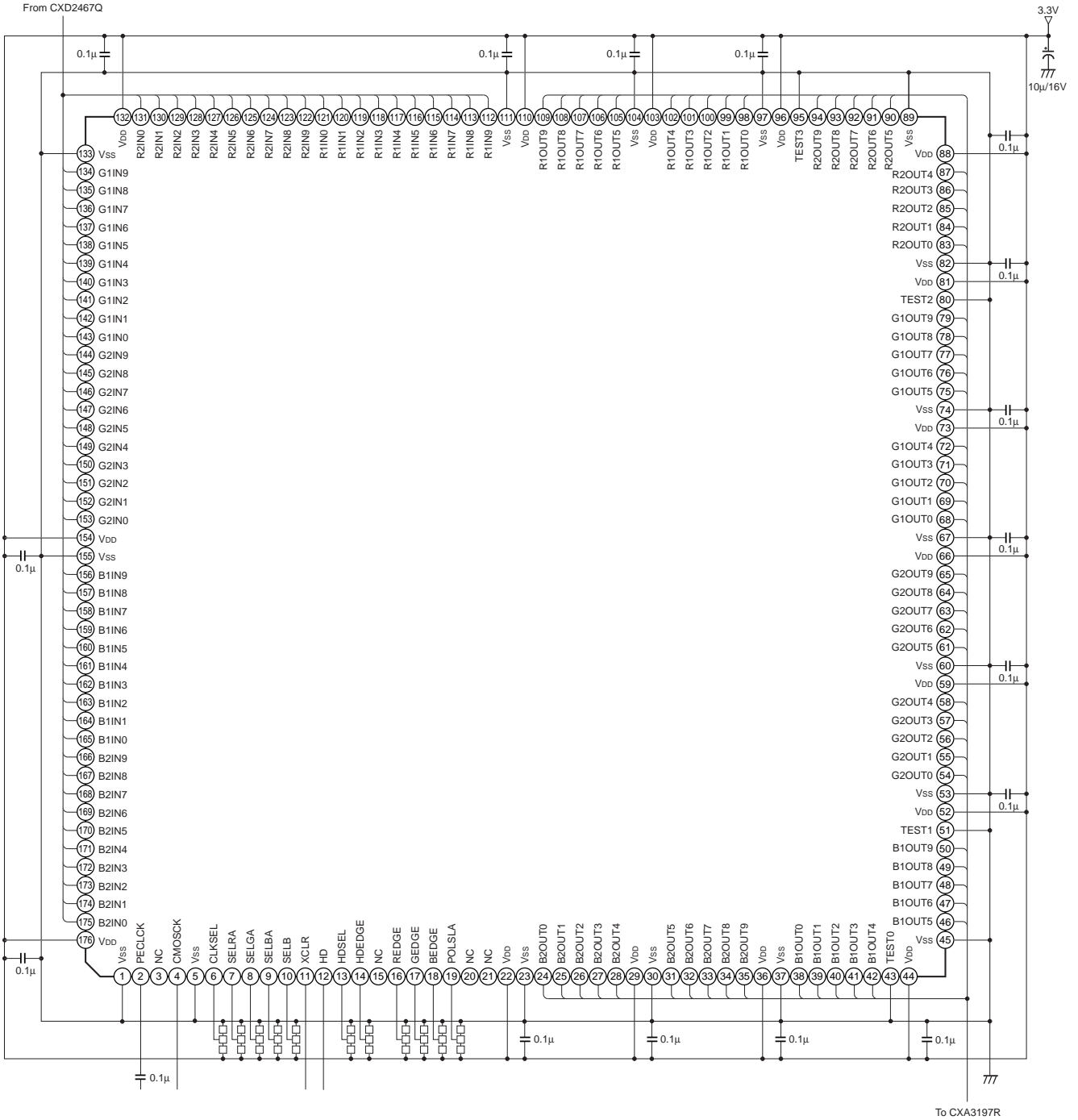

Application circuits shown are typical examples illustrating the operation of the devices. Sony cannot assume responsibility for any problems arising out of the use of these circuits or for any infringement of third party patent and other right due to same.

Package Outline Unit: mm

176PIN LQFP(PLASTIC)

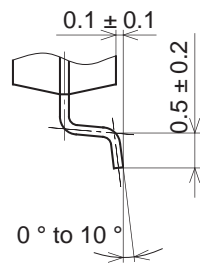
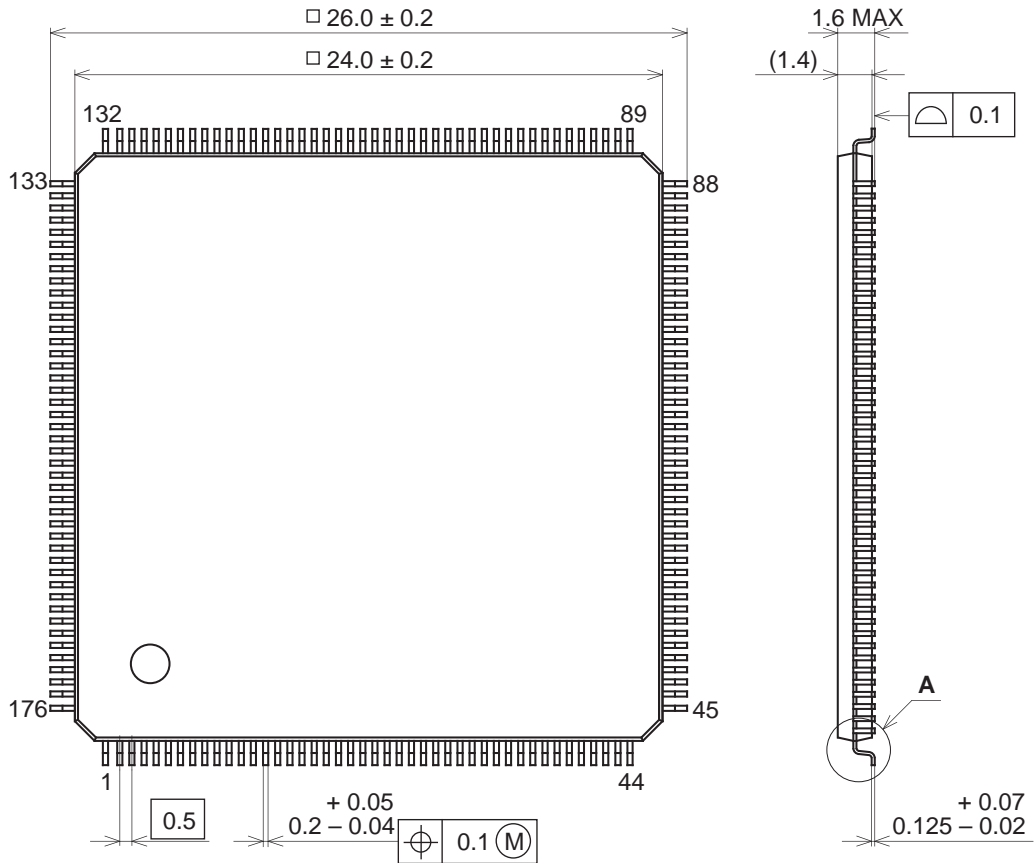

DETAIL A

PACKAGE STRUCTURE

SONY CODE	LQFP-176P-L061
EIAJ CODE	P-LQFP176-24X24-0.5
JEDEC CODE	—

PACKAGE MATERIAL	EPOXY RESIN
LEAD TREATMENT	SOLDER PLATING
LEAD MATERIAL	42 ALLOY
PACKAGE MASS	1.8 g



LittleDiode supplies new, hard to find or obsolete electronic components and semiconductors all over the world.

With over two million different components listed you are sure to find the part you need.

Feel free to visit us today at our online store:

LittleDiode.com

Looking forward to providing you with the best possible service.