

Super Audio CD Format Book ANNEX D&E Conformal Metering

Description

The CXD2755Q is the signal processor for signal level measurement of DSD (Direct Stream Digital) conformed to ANNEX D&E of Super Audio CD Format Book V1.2. This LSI can measure up to 8 channel DSD signals to detect the maximum level of each frequency band specified in ANNEX D&E of Super Audio CD format and output the peak values of every 44.1kHz cycle for the signal level measurement and display.

Functions

- Up to 8 channels of 1bit, 2.8224MHz (44.1kHz × 64) DSD input supported.
- MaxPeak measurement (ANNEX D3):
28-tap 1st-order moving average filter is used for MaxPeak level measurement.
- DC removal filter:
DC removal filter ($f_c = \text{about } 0.1\text{Hz}$) is inserted to HF/MF/LF filters.
- HF measurement (ANNEX D4):
40kHz 5th-order Butterworth high-pass filter and 100kHz 5th-order Butterworth low-pass filter are used for HF band measurement. In addition, "Mean-Square" and "Square-Root" are calculated for RMS metering.
- MF measurement (ANNEX E2):
20kHz 10th-order Butterworth high-pass filter and 50kHz 5th-order Butterworth low-pass filter are used for MF band measurement.
- LF measurement:
20kHz 10th-order Butterworth low-pass filter is used for LF band measurement.
- DC measurement (ANNEX E4):
0.1Hz 2nd-order low-pass filter is used for DC measurement.
- MF over warning flag (ANNEX E2):
As the MF specification has the exceptional condition for warning, the signal level of MF and LF are continuously compared and output the warning status from this LSI.

Sony reserves the right to change products and specifications without prior notice. This information does not convey any license by any implication or otherwise under any patents or other right. Application circuits shown, if any, are typical examples illustrating the operation of the devices. Sony cannot assume responsibility for any problems arising out of the use of these circuits.

208 pin QFP (Plastic)

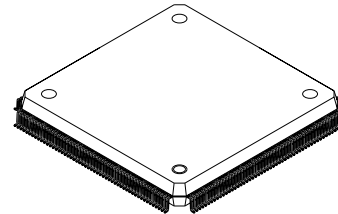

Structure

Silicon gate CMOS IC

Absolute Maximum Ratings (Ta = 25°C)

- Supply voltage V_{DD} $V_{SS} - 0.5$ to $+4.6$ V
- Input voltage V_I $V_{SS} - 0.5$ to $V_{DD} + 0.5$ V
- Output voltage V_O $V_{SS} - 0.5$ to $V_{DD} + 0.5$ V
- Storage temperature
 T_{stg} -55 to $+150$ °C

Recommended Operating Conditions

- Supply voltage V_{DD} 3.0 to 3.6 V
- Operating temperature
 T_{opr} -10 to $+75$ °C

Input/Output Capacitance

- Input capacitance C_I Max. 9pF
- Output capacitance C_O Max. 11pF

Note) Measurement conditions

$$V_{DD} = V_I = 0V, f_M = 1\text{MHz}$$

Block Diagram

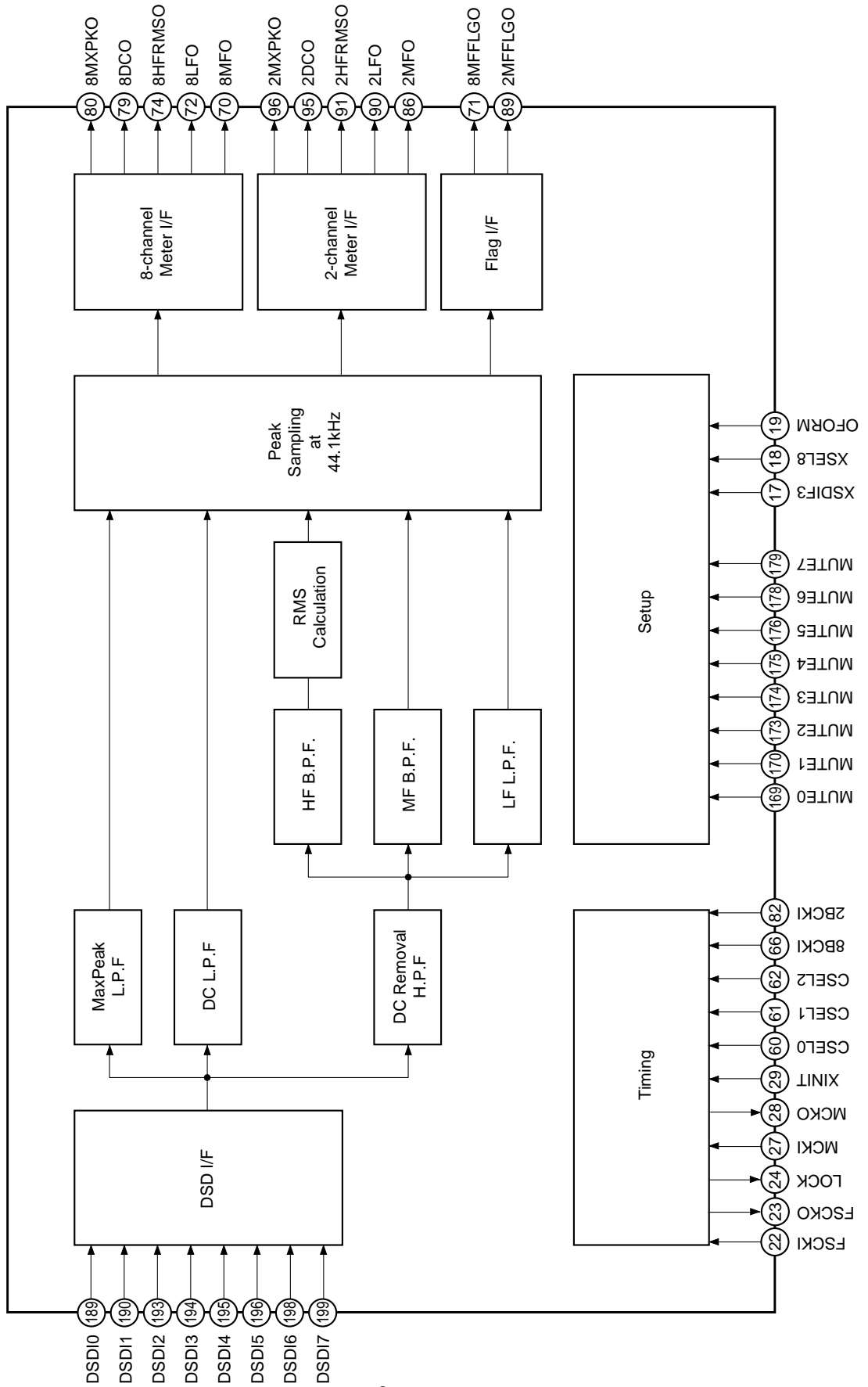

Pin Configuration

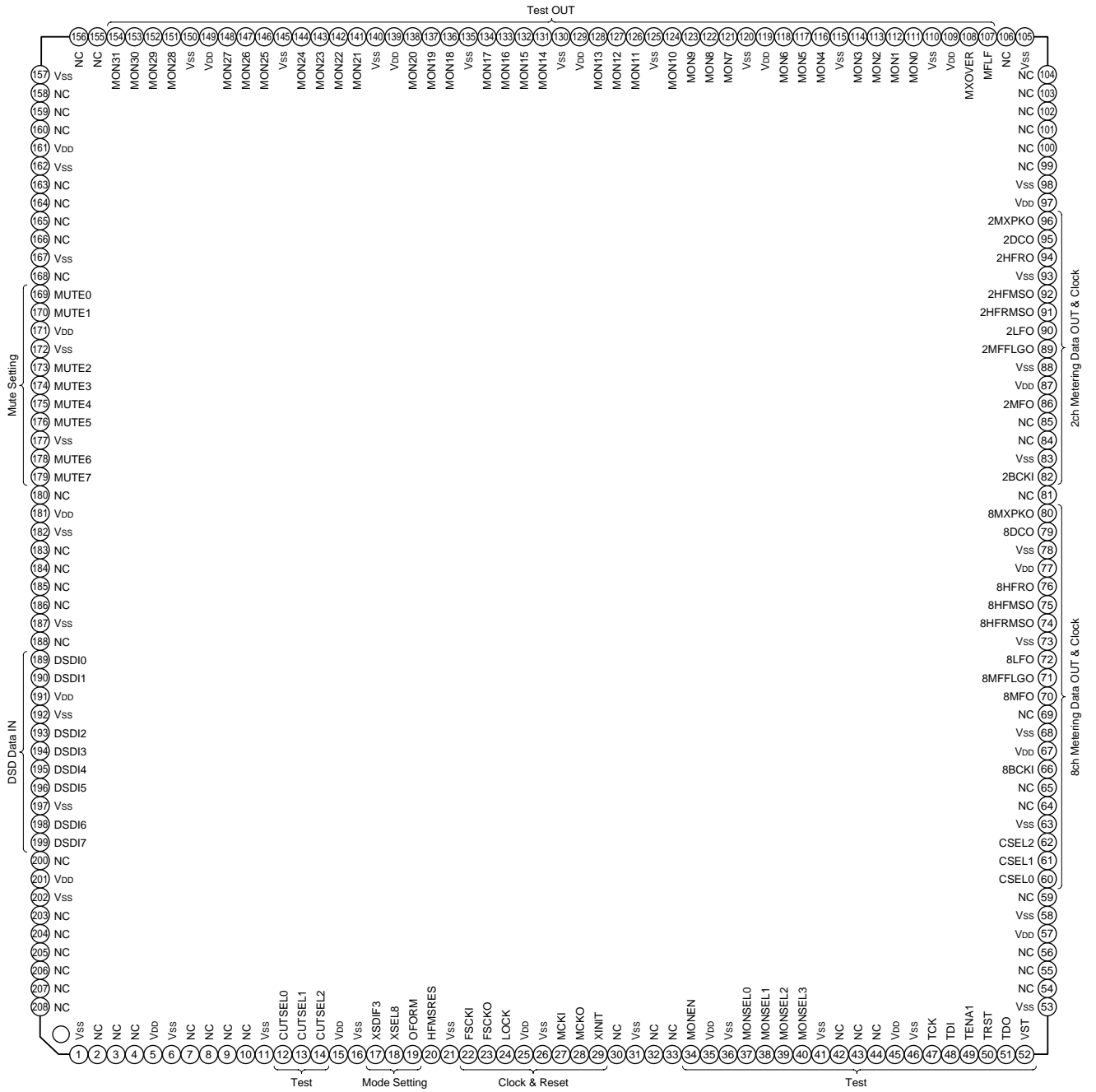

Pin Description

Pin No.	Symbol	I/O	Description
1	V _{SS}		
2	NC		
3	NC		
4	NC		
5	V _{DD}		
6	V _{SS}		
7	NC		
8	NC		
9	NC		
10	NC		
11	V _{SS}		
12	CUTSEL0	Ipd	NC.
13	CUTSEL1	Ipd	NC.
14	CUTSEL2	Ipd	NC.
15	V _{DD}		
16	V _{SS}		
17	XSDIF3	Ipu	DSD input format setting. (High: DSD-raw/Low: SDIF-3)
18	XSEL8	Ipd	Output channels setting. (High: 2-channel/Low: 8-channel)
19	OFORM	Ipu	Output format setting. (High: MSB first, left justified/Low: LSB first, right justified)
20	HFMSRES	Ipu	NC.
21	V _{SS}		
22	FSCKI	Isc	Base-band sampling frequency (Fs) input. Fs = 44.1kHz
23	FSCKO	O	Generated base-band sampling frequency (Fs) output. Fs = 44.1kHz
24	LOCK	O	Status flag of synchronization between FSCKI and FSCKO. (High: Locked/Low: Un-locked)
25	V _{DD}		
26	V _{SS}		
27	MCKI	I	Master clock input. MCKI = 22.5792MHz (512Fs)
28	MCKO	O	Buffered master clock output.
29	XINIT	Ipu	System initialization at Low level. (I/O clock is active while initializing.)
30	NC		
31	V _{SS}		
32	NC		
33	NC		
34	MONEN	Ipd	NC.
35	V _{DD}		

* I_{sc}: Hysteresis (Schmitt) input / I_{pu}: Pulled-up input / I_{pd}: Pulled-down input

Pin No.	Symbol	I/O	Description
36	V _{SS}		
37	MONSEL0	l _{pd}	NC.
38	MONSEL1	l _{pd}	NC.
39	MONSEL2	l _{pd}	NC.
40	MONSEL3	l _{pd}	NC.
41	V _{SS}		
42	NC		
43	NC		
44	NC		
45	V _{DD}		
46	V _{SS}		
47	TCK	l _{pu}	NC.
48	TDI	l _{pu}	NC.
49	TENA1	l _{pu}	NC.
50	TRST	l _{pu}	Fixed to Low level or input Power on reset signal.
51	TDO	O	NC.
52	VST		GND. (V _{SS} for test circuit)
53	V _{SS}		
54	NC		
55	NC		
56	NC		
57	V _{DD}		
58	V _{SS}		
59	NC		
60	CSEL0	I	Channel select input 0 for 8-channel output stream. (Normally, 4Fs clock should be input.)
61	CSEL1	I	Channel select input 1 for 8-channel output stream. (Normally, 2Fs clock should be input.)
62	CSEL2	I	Channel select input 2 for 8-channel output stream. (Normally, 1Fs clock should be input.)
63	V _{SS}		
64	NC		
65	NC		
66	8BCKI	I _{sc}	Bit clock input for 8-channel output stream. (Normally, 256Fs clock should be input.)
67	V _{DD}		
68	V _{SS}		
69	NC		

* I_{sc}: Hysteresis (Schmitt) input / I_{pu}: Pulled-up input / I_{pd}: Pulled-down input

Pin No.	Symbol	I/O	Description
70	8MFO	O	8-channel MF band (20kHz to 50kHz) data output.
71	8MFFLGO	O	8-channel MF band (20kHz to 50kHz) level warning status output.
72	8LFO	O	8-channel LF band (up to 20kHz) data output.
73	V _{SS}		
74	8HFRMSO	O	8-channel HF band (40kHz to 100kHz) RMS calculated data output.
75	8HFMSO	O	NC.
76	8HFRO	O	NC.
77	V _{DD}		
78	V _{SS}		
79	8DCO	O	8-channel DC (up to 0.1Hz) data output.
80	8MXPKO	O	8-channel MaxPeak (up to 50kHz) data output.
81	NC		
82	2BCKI	I _{sc}	Bit clock input for 2-channel output stream. (Normally 64Fs clock should be input.)
83	V _{SS}		
84	NC		
85	NC		
86	2MFO	O	2-channel MF band (20kHz to 50kHz) data output.
87	V _{DD}		
88	V _{SS}		
89	2MFFLGO	O	2-channel MF band (20kHz to 50kHz) level warning status output.
90	2LFO	O	2-channel LF band (up to 20kHz) data output.
91	2HFRMSO	O	2-channel HF band (40kHz to 100kHz) RMS calculated data output.
92	2HFMSO	O	NC.
93	V _{SS}		
94	2HFRO	O	NC.
95	2DCO	O	2-channel DC (up to 0.1Hz) data output.
96	2MXPKO	O	2-channel MaxPeak (up to 50kHz) data output.
97	V _{DD}		
98	V _{SS}		
99	NC		
100	NC		
101	NC		
102	NC		
103	NC		
104	NC		
105	V _{SS}		

* I_{sc}: Hysteresis (Schmitt) input / I_{pu}: Pulled-up input / I_{pd}: Pulled-down input

Pin No.	Symbol	I/O	Description
106	NC		
107	MFLF	O	NC.
108	MXOVER	O	NC.
109	V _{DD}		
110	V _{SS}		
111	MON0	O	NC.
112	MON1	O	NC.
113	MON2	O	NC.
114	MON3	O	NC.
115	V _{SS}		
116	MON4	O	NC.
117	MON5	O	NC.
118	MON6	O	NC.
119	V _{DD}		
120	V _{SS}		
121	MON7	O	NC.
122	MON8	O	NC.
123	MON9	O	NC.
124	MON10	O	NC.
125	V _{SS}		
126	MON11	O	NC.
127	MON12	O	NC.
128	MON13	O	NC.
129	V _{DD}		
130	V _{SS}		
131	MON14	O	NC.
132	MON15	O	NC.
133	MON16	O	NC.
134	MON17	O	NC.
135	V _{SS}		
136	MON18	O	NC.
137	MON19	O	NC.
138	MON20	O	NC.
139	V _{DD}		
140	V _{SS}		
141	MON21	O	NC.

* Isc: Hysteresis (Schmitt) input / Ipu: Pulled-up input / Ipd: Pulled-down input

Pin No.	Symbol	I/O	Description
142	MON22	O	NC.
143	MON23	O	NC.
144	MON24	O	NC.
145	V _{SS}		
146	MON25	O	NC.
147	MON26	O	NC.
148	MON27	O	NC.
149	V _{DD}		
150	V _{SS}		
151	MON28	O	NC.
152	MON29	O	NC.
153	MON30	O	NC.
154	MON31	O	NC.
155	NC		
156	NC		
157	V _{SS}		
158	NC		
159	NC		
160	NC		
161	V _{DD}		
162	V _{SS}		
163	NC		
164	NC		
165	NC		
166	NC		
167	V _{SS}		
168	NC		
169	MUTE0	Ipd	DSD channel 0 input mute. (High: mute/Low: normal input)
170	MUTE1	Ipd	DSD channel 1 input mute. (High: mute/Low: normal input)
171	V _{DD}		
172	V _{SS}		
173	MUTE2	Ipd	DSD channel 2 input mute. (High: mute/Low: normal input)
174	MUTE3	Ipd	DSD channel 3 input mute. (High: mute/Low: normal input)
175	MUTE4	Ipd	DSD channel 4 input mute. (High: mute/Low: normal input)
176	MUTE5	Ipd	DSD channel 5 input mute. (High: mute/Low: normal input)
177	V _{SS}		

* Isc: Hysteresis (Schmitt) input / Ipu: Pulled-up input / Ipd: Pulled-down input

Pin No.	Symbol	I/O	Description
178	MUTE6	l _{pd}	DSD channel 6 input mute. (High: mute/Low: normal input)
179	MUTE7	l _{pd}	DSD channel 7 input mute. (High: mute/Low: normal input)
180	NC		
181	V _{DD}		
182	V _{SS}		
183	NC		
184	NC		
185	NC		
186	NC		
187	V _{SS}		
188	NC		
189	DSDI0	l _{sc}	DSD channel 0 input.
190	DSDI1	l _{sc}	DSD channel 1 input.
191	V _{DD}		
192	V _{SS}		
193	DSDI2	l _{sc}	DSD channel 2 input.
194	DSDI3	l _{sc}	DSD channel 3 input.
195	DSDI4	l _{sc}	DSD channel 4 input.
196	DSDI5	l _{sc}	DSD channel 5 input.
197	V _{SS}		
198	DSDI6	l _{sc}	DSD channel 6 input.
199	DSDI7	l _{sc}	DSD channel 7 input.
200	NC		
201	V _{DD}		
202	V _{SS}		
203	NC		
204	NC		
205	NC		
206	NC		
207	NC		
208	NC		

* l_{sc}: Hysteresis (Schmitt) input / l_{pu}: Pulled-up input / l_{pd}: Pulled-down input

Electrical Characteristics

DC Characteristics

($V_{DD} = 3.0$ to $3.6V$, $T_{opr} = -20$ to $+75^{\circ}C$)

Item	Symbol	Conditions	Min.	Typ.	Max.	Unit	Applicable pins
Input voltage	High level	V_{IH}	$0.7V_{DD}$			V	*1, *3, *4
	Low level	V_{IL}			$0.2V_{DD}$	V	*1, *3, *4
Input voltage	High level	V_{T+}	$0.7V_{DD}$			V	*5
	Low level	V_{T-}			$0.2V_{DD}$	V	*5
	Hysteresis	$V_{T+} - V_{T-}$		0.5		V	*5
Output voltage	High level	V_{OH}	$I_{OH} = -4.0mA$	$V_{DD} - 0.4$		V	*2
	Low level	V_{OL}	$I_{OL} = 4.0mA$		0.4	V	*2
Input leak (1)	I_{IH}	$V_{IH} = V_{DD}$	40	100	240	μA	*4
Input leak (2)	I_{IL}	$V_{IL} = 0V$	-240	-100	-40	μA	*3
Input leak (3)	I_I	$V = V_{DD}$ or $0V$	-10		10	μA	*1, *5

*1 MCKI, CSEL0, CSEL1, CSEL2

*2 FSCKO, LOCK, MCKO, 8MFO, 8MFFLGO, 8LFO, 8HFRMSO, 8HFMSO, 8HFRO, 8DCO, 8MXPKO, 2MFO, 2MFFLGO, 2LFO, 2HFRMSO, 2HFMSO, 2HFRO, 2DCO, 2MXPKO, MFLF, MXOVER, MON0 to MON31

*3 XSDIF3, OFORM, HFMSRES, XINIT, TCK, TDI, TENA1, TRST

*4 CUTSEL0, CUTSEL1, CUTSEL2, XSEL8, MONEN, MONSEL0 to MONSEL3, MUTE0 to MUTE7

*5 FSCKI, 2BCKI, 8BCKI, DSDI0 to DSDI7

AC Characteristics

1. Master Clock (MCKI, MCKO pins)

($V_{DD} = 3.0$ to $3.6V$, $T_{opr} = -20$ to $+75^{\circ}C$)

Item	Symbol	Min.	Typ.	Max.	Unit
MCKI frequency	fmck	—	22.5792	—	MHz
MCKI pulse width	twmck	15.28	22.14	—	ns
Propagation delay from MCKI rise to MCKO rise	tphmck	5.12	10.73	22.24	ns
Propagation delay from MCKI fall to MCKO fall	tplmck	5.41	11.34	23.52	ns

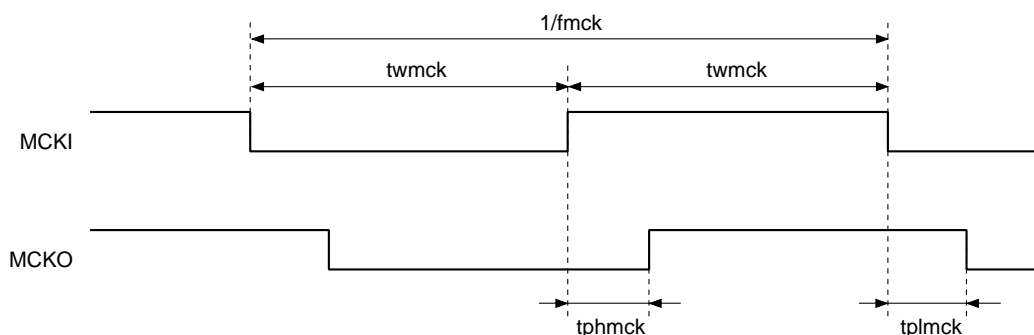

2. Output for 2-Channel Meter (FSCKI, FSCKO, 2BCKI, 2***O) (V_{DD} = 3.0 to 3.6V, Topr = -20 to +75°C)

Item	Symbol	Min.	Typ.	Max.	Unit
FSCKI frequency	ffscki	—	44.1	—	kHz
FSCKO rise time from FSCKI rise	tfsczkodly	-39.2* ¹	10.7* ²	66.5* ³	ns
2BCKI frequency	f2bcki	—	2.8224	—	MHz
2BCKI clock pulse width (High)	tw2bckih	143	177	211	ns
2BCKI clock pulse width (Low)	tw2bckil	143	177	211	ns
FSCKO setup time, relative to 2BCKI rise	tsufscsko	143	177	211	ns
FSCKO hold time, relative to 2BCKI rise	thdfscsko	143	177	211	ns
2BCKI fall setup time, relative to MCKI rise	tsu2bckil	2.3	5.0	10.3	ns
2BCKI rise setup time, relative to MCKI rise	tsu2bckih	2.2	4.7	9.8	ns
2***O change time from 2BCKI fall	t2***odly	12.1	25.6	52.9	ns

*1 Minimum gate delay -1MCK

*2 Typical gate delay

*3 Maximum gate delay +1MCK

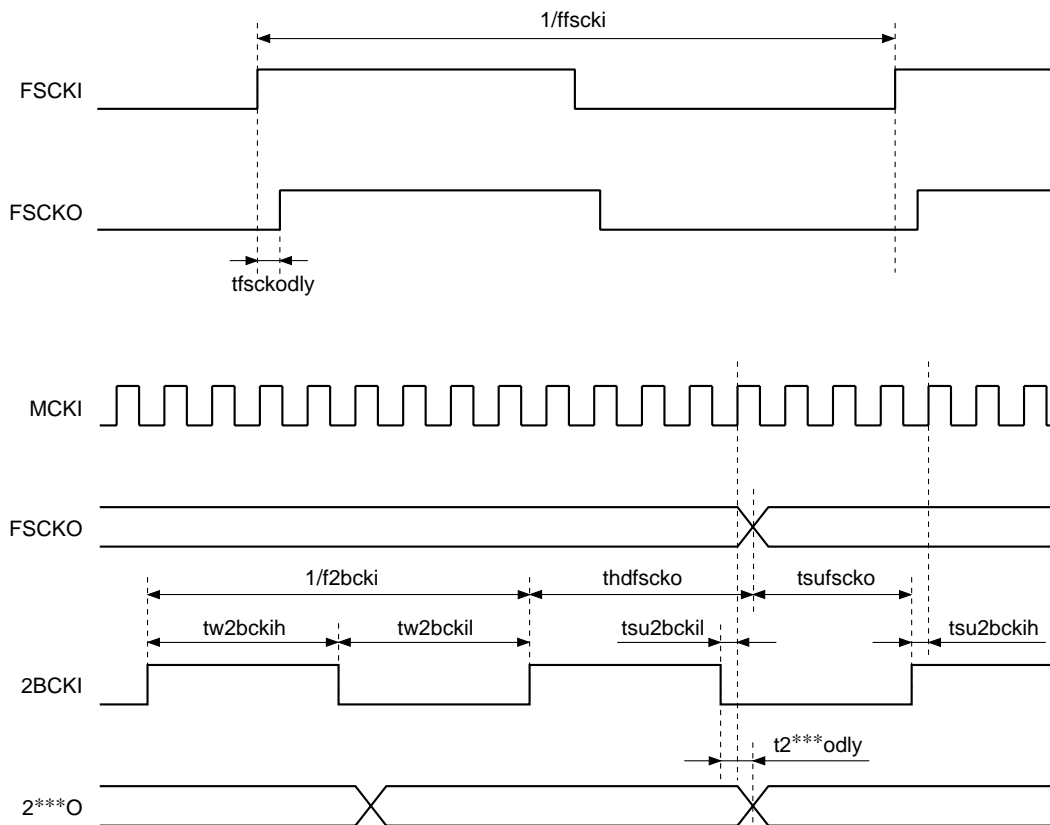

3. Output for 8-Channel Meter (CSEL*, 8BCKI, 8***O)

(V_{DD} = 3.0 to 3.6V, Topr = -20 to +75°C)

Item	Symbol	Min.	Typ.	Max.	Unit
CSEL0 frequency	f _{csel0}	—	176.4	—	kHz
CSEL1 frequency	f _{csel1}	—	88.2	—	kHz
CSEL2 frequency	f _{csel2}	—	44.1	—	kHz
8BCKI frequency	f _{8bcki}	—	11.2896	—	MHz
8BCKI clock pulse width (High)	tw _{8bckih}	—	44.3	—	ns
8BCKI clock pulse width (Low)	tw _{8bckil}	—	44.3	—	ns
8BCKI fall setup time, relative to MCKI rise	tsu _{8bckil}	3.6	7.6	15.8	ns
8BCKI rise setup time, relative to MCKI rise	tsu _{8bckih}	3.1	6.6	13.8	ns
CSEL* setup time, relative to 8BCKI rise	tsuf _{scko}	-44.3		44.3	ns
CSEL* hold time, relative to 8BCKI rise	thd _{f_{scko}}	-44.3		44.3	ns
8***O change time from 8BCKI fall	t _{8***odly}	13.4	28.2	58.4	ns

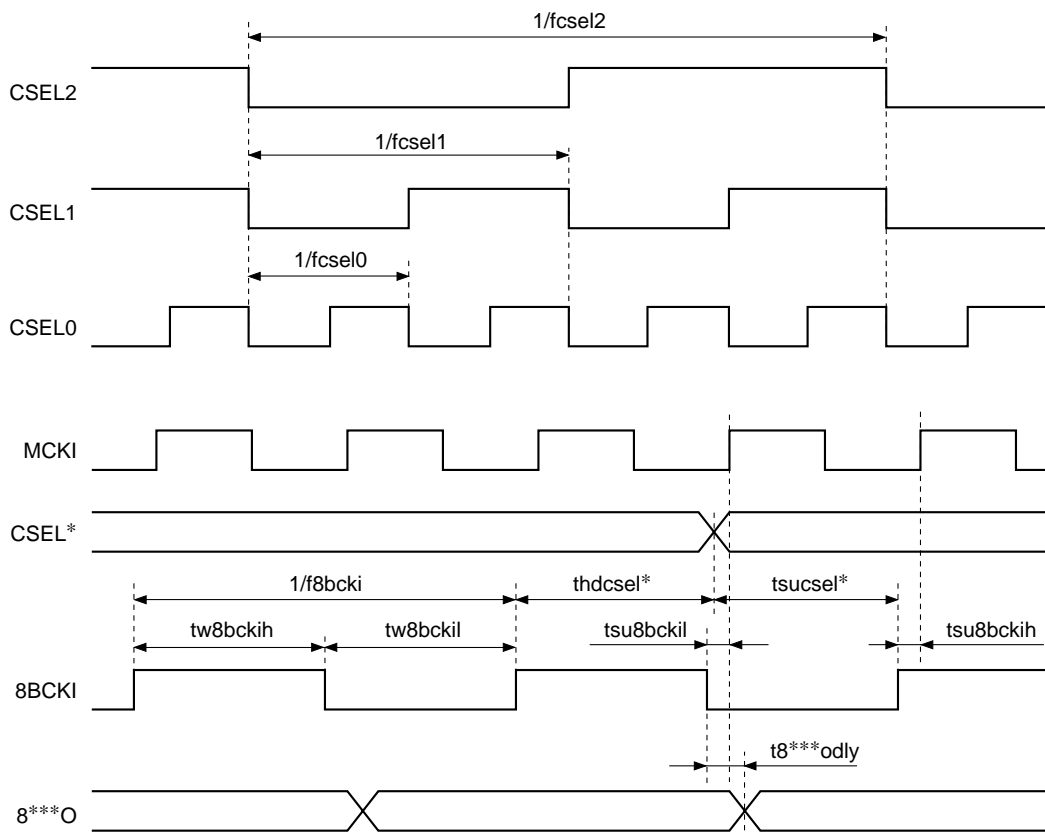

Description of Functions

Description of Operation Modes

This LSI has two operating modes.

- 2-channel mode: Detect the maximum level of each frequency band specified in ANNEX D&E of Super Audio CD format and output the peak values of every 44.1kHz cycle for stereo signal level measurement and display.
- 8-channel mode: Detect the maximum level of each frequency band specified in ANNEX D&E of Super Audio CD format and output the peak values of every 44.1kHz cycle for signal level measurement and display up to 8 channels.

1) Description of 2-Channel Mode

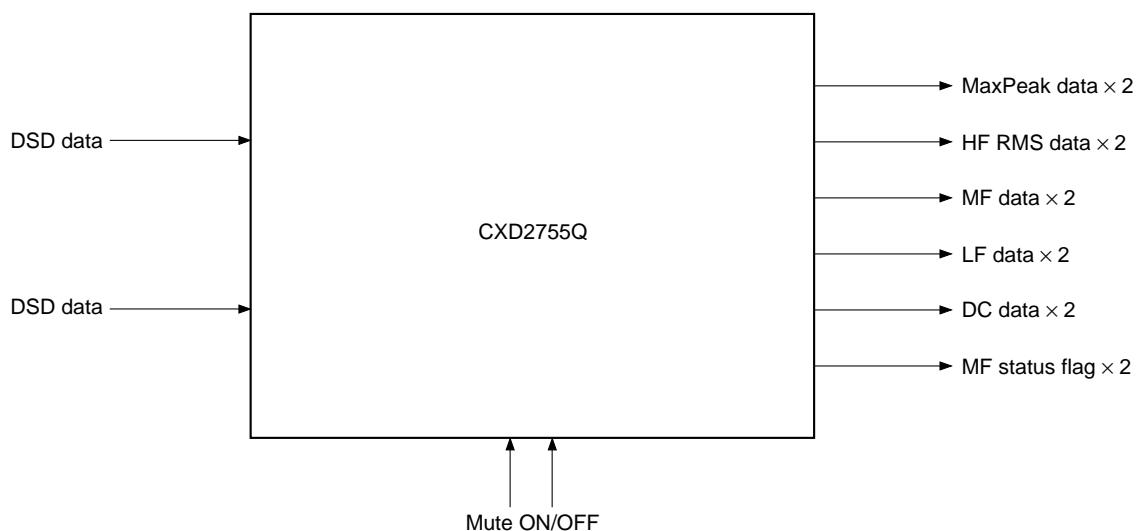

2) Description of 8-Channel Mode

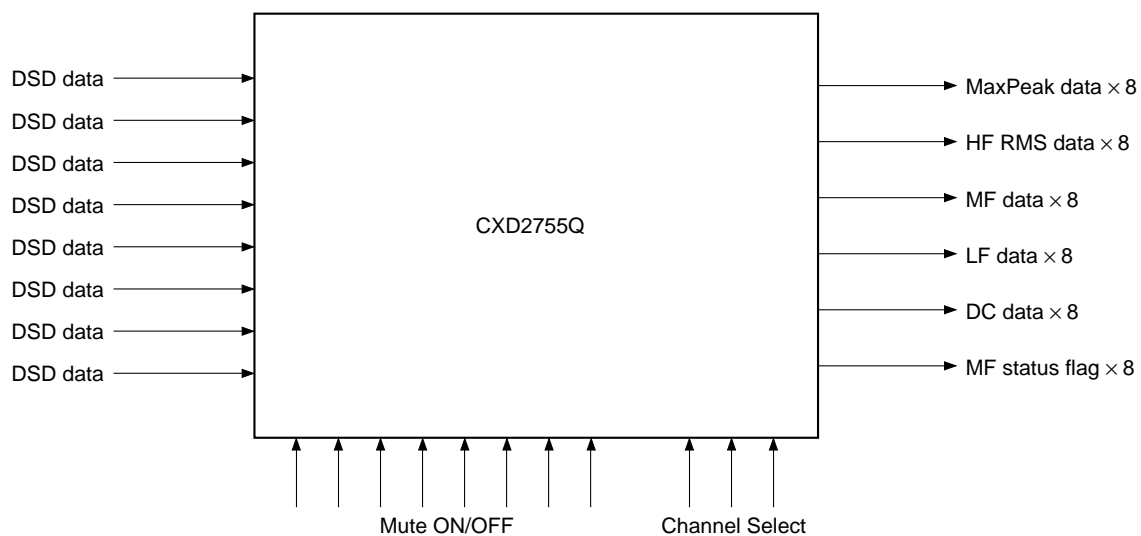

Setup

This LSI can setup the various functions by parallel setting which sets the functions according to the pin High and Low levels.

Setup Pins and Their Contents

Pin No.	Symbol	Contents	High	Low	Effective modes	
					2-channel	8-channel
17	XSDIF3	DSD input format setting	DSD-raw	SDIF-3	O	O
18	XSEL8	Output channel setting	2-channel	8-channel	O	O
19	OFORM	Output format setting	MSB first, left justified	LSB first, right justified	O	O
169	MUTE0	DSD channel 0 input mute	Mute	Normal input	O	O
170	MUTE1	DSD channel 1 input mute	Mute	Normal input	O	O
173	MUTE2	DSD channel 2 input mute	Mute	Normal input		O
174	MUTE3	DSD channel 3 input mute	Mute	Normal input		O
175	MUTE4	DSD channel 4 input mute	Mute	Normal input		O
176	MUTE5	DSD channel 5 input mute	Mute	Normal input		O
178	MUTE6	DSD channel 6 input mute	Mute	Normal input		O
179	MUTE7	DSD channel 7 input mute	Mute	Normal input		O

1. 2-Channel Mode

1-1. Input/Output Signals

DSDI0, DSDI1: Input the 2-channel DSD data

2MXPKO: Output the 2-channel MaxPeak (ANNEX D3) data

2HFRMSO: Output the 2-channel HF RMS (ANNEX D4) calculated data

2MFO: Output the 2-channel MF (ANNEX E2) data

2MFFLGO: Output the 2-channel status flags for MF (ANNEX E2) warning

2LFO: Output the 2-channel LF data

2DCO: Output the 2-channel DC (ANNEX E4) data

1-2. DSD Data Input

The 1-bit DSD data with 2.8224MHz ($44.1\text{kHz} \times 64$) sampling frequency is input to the DSDI0 and DSDI1 pins. As the input circuit detects the data edge for data acquisition internally, any bit clock is not necessary. Assure the input signal format (DSD-raw or SDIF-3) and select the proper mode by the XSDIF3 pin.

XSDIF3 = High: DSD-raw format

XSDIF3 = Low: SDIF-3 format

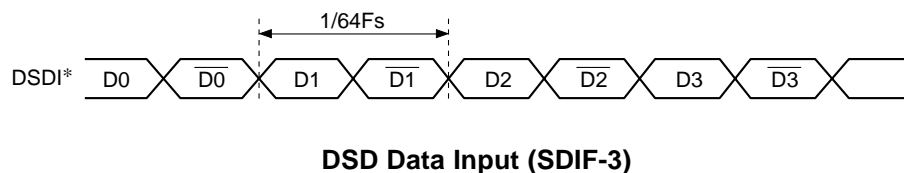
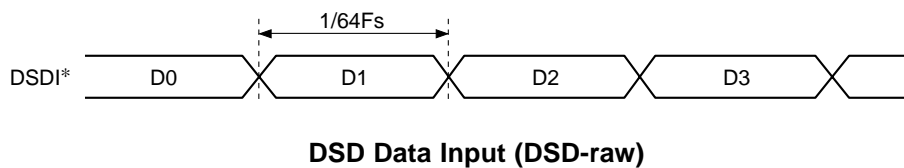

1-3. Metering Data Output

Each metering data output is expressed as two's complement data except for 2MFFLGO and formed to be the left justified MSB first or right justified LSB first by the OFORM pin setting. The resolution of each metering data is 16 bits and read out by $64F_s$ 2BCKI clock. The reference level of SACD (0dB SACD) corresponds to 3FFF (H) or C000 (H) in order to display up to +6dB SACD except for MaxPeak.

* 0dB SACD for MaxPeak is 3800 (H) or C800 (H), then 7000 (H) or 9000 (H) at +6dB SACD.

Output Format

OFORM = High: MSB first, left justified

OFORM = Low: LSB first, right justified

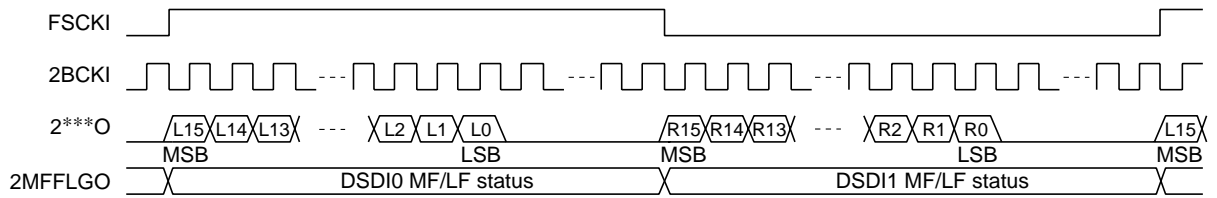

OFORM (MSB first, left justified)

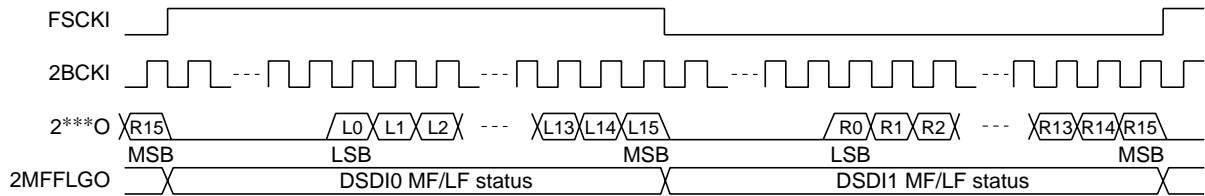

OFORM (LSB first, right justified)

MaxPeak (ANNEX D3)

The MaxPeak filter consists of 28-tap 1st-order moving average filter for quasi-50kHz bandwidth signal level monitoring.

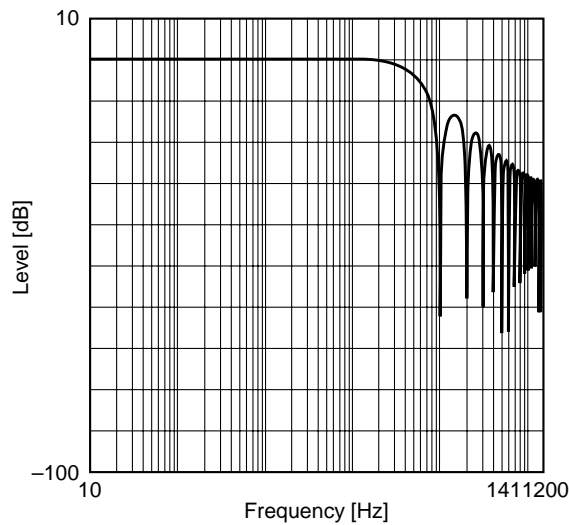

MaxPeak Filter Frequency Response

In the SACD Format Book V1.2, up to +3.1dBSACD MaxPeak is allowed and it corresponds to 5000 (H) or B000 (H). The correspondence between the MaxPeak signal level and the output codes is as follows.

MaxPeak signal level	Output code		Status
+6.02dBSACD	7000 (H)	9000 (H)	Format Error
+5.38dBSACD	6800 (H)	9800 (H)	Format Error
+4.68dBSACD	6000 (H)	A000 (H)	Format Error
+3.93dBSACD	5800 (H)	A800 (H)	Format Error
+3.10dBSACD	5000 (H)	B000 (H)	OK
+2.18dBSACD	4800 (H)	B800 (H)	OK
+1.16dBSACD	4000 (H)	C000 (H)	OK
0dBSACD	3800 (H)	C800 (H)	OK
-1.34dBSACD	3000 (H)	D000 (H)	OK
-2.92dBSACD	2800 (H)	D800 (H)	OK
-4.86dBSACD	2000 (H)	E000 (H)	OK
-7.36dBSACD	1800 (H)	E800 (H)	OK
-10.88dBSACD	1000 (H)	F000 (H)	OK
-16.90dBSACD	0800 (H)	F800 (H)	OK
-∞dBSACD	0000 (H)		OK

MaxPeak Signal Level vs. Output Codes

As over +3.1dBSACD MaxPeak is prohibited, SACD mastering meter should indicate "Format Error" for over +3.1dBSACD MaxPeak signals.

HF RMS (ANNEX D4)

HF filter consists of 40kHz cut-off 5th-order Butterworth high-pass filter and 100kHz cut-off 5th-order Butterworth low-pass filter for high frequency noise power monitoring. For noise power monitoring, Mean-Square and Square-Root are calculated for RMS metering internally.

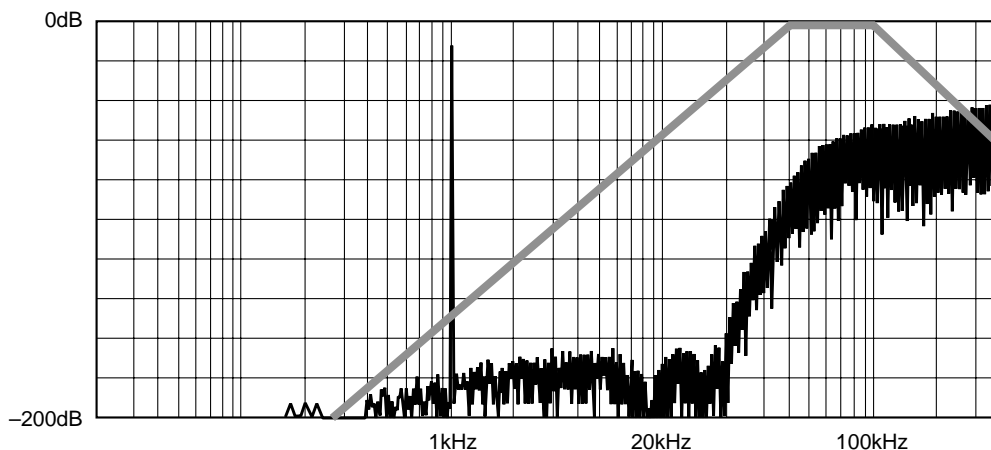

HF Filter Frequency Response

In the SACD Format Book V1.2, up to $-20\text{dB}_{\text{SACD}}$ HF RMS is allowed. As the output code contains -3.01dB offset for the sine wave input because of RMS calculation, $+3.01\text{dB}$ offset should be added for actual metering and -23.01dB output becomes equivalent to $-20\text{dB}_{\text{SACD}}$. Therefore, the correspondence between HF RMS and output codes is as follows.

HF RMS signal level	Output readout	Output code		Status
:	:	:	:	:
$+3.01\text{dB}_{\text{SACD}}$	$+0\text{dB}$	3FFF (H)	C000 (H)	Format Error
:	:	:	:	:
0dB_{SACD}	-3.01dB	2D40 (H)	D2BF (H)	Format Error
:	:	:	:	:
$-19.99\text{dB}_{\text{SACD}}$	-23.00dB	0487 (H)	FB78 (H)	Format Error
$-20.00\text{dB}_{\text{SACD}}$	-23.01dB	0486 (H)	FB79 (H)	OK
:	:	:	:	:

HF RMS vs. Output Codes

As over $-20\text{dB}_{\text{SACD}}$ HF RMS is prohibited, the SACD mastering meter should indicate "Format Error" for over $-20\text{dB}_{\text{SACD}}$ HF RMS.

MF (ANNEX E2)

MF filter consists of 20kHz cut-off 10th-order Butterworth high-pass filter and 50kHz cut-off 5th-order Butterworth low-pass filter for high frequency signal and noise level monitoring.

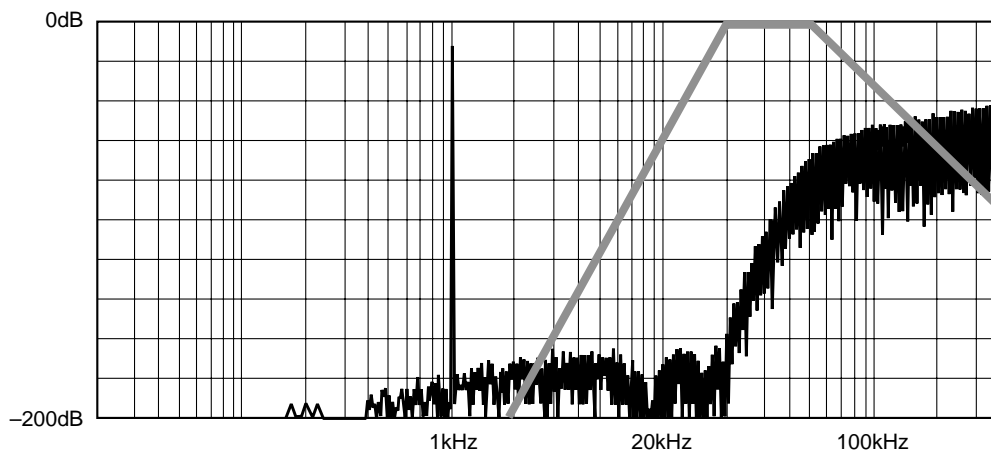

MF Filter Frequency Response

In the SACD Format Book V1.2, over -28dBSACD MF signal is not recommended while LF is lower than MF. However, any MF signal is allowed if MF is lower than LF. The correspondence between the MF signal level and the output codes is as follows.

MF signal level	Output code		Status
:	:	:	:
0dBSACD	3FFF (H)	C000 (H)	See MFFLGO
:	:	:	:
-27.98dBSACD	028D (H)	FD72 (H)	See MFFLGO
-28.00dBSACD	028C (H)	FD73 (H)	OK
:	:	:	:

MF vs. Output Codes

MF Status Flags (ANNEX E2)

MF status flags indicate the ANNEX E2 warning condition. If the internal comparator detects over -28dBSACD MF signals while LF is lower than MF, 2MFFLGO becomes "High". If MF is lower than LF, 2MFFLGO stays "Low". Therefore, 2MFFLGO can be use for ANNEX E2 warning.

LF

LF filter consists of 20kHz cut-off 10th-order Butterworth low-pass filter for audio frequency signal level monitoring.

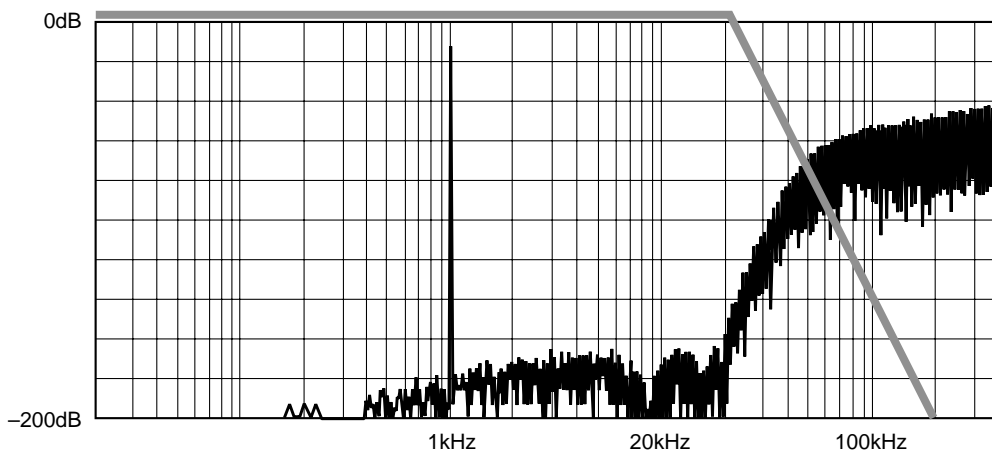

LF Filter Frequency Response

In the SACD Format Book V1.2, LF is not specified, however, LF is used for comparison with MF for MF warning. The correspondence between the LF signal level and the output codes is as follows.

LF signal level	Output code	
:	:	:
0dBSACD	3FFF (H)	C000 (H)
:	:	:

LF vs. Output Codes

DC (ANNEX E4)

The DC filter consists of 0.1Hz cut-off 2nd-order (cascaded 1st-order) low-pass filter for DC offset monitoring. In the SACD Format Book V1.2, over -50dBSACD DC offset is not recommended. The correspondence between the DC offset and the output codes is as follows.

DC signal level	Output code		Status
:	:	:	:
0dBSACD	3FFF (H)	C000 (H)	Warning
:	:	:	:
-49.96dBSACD	0034 (H)	FFCB (H)	Warning
-50.13dBSACD	0033 (H)	FFCC (H)	OK
:	:	:	:

DC vs. Output Codes

2. 8-Channel Mode

2-1. Input/Output Signals

DSDI0 to DSDI7: Input the 8-channel DSD data

CSEL0 to CSEL2: Input the channel select signal

8MXPKO: Output the 8-channel MaxPeak (ANNEX D3) data

8HFRMSO: Output the 8-channel HF RMS (ANNEX D4) calculated data

8MFO: Output the 8-channel MF (ANNEX E2) data

8MFFLGO: Output the 8-channel status flags for MF (ANNEX E2) warning

8LFO: Output the 8-channel LF data

8DCO: Output the 8-channel DC (ANNEX E4) data

2-2. DSD Data Input

See 1-2.

2-3. Metering Data Output

Each metering data output is expressed as two's complement data except for 8MFFLGO and formed to be the left justified MSB first or right justified LSB first by OFORM pin setting. The resolution of each metering data is 16 bits and read out with 256Fs 8BCKI clock. The reference level of SACD (0dB SACD) corresponds to 3FFF (H) or C000 (H) in order to display up to +6dB SACD except for MaxPeak.

*0dB SACD for MaxPeak is 3800 (H) or C800 (H), then 7000 (H) or 9000 (H) at +6dB SACD.

Output Format

OFORM = High: MSB first, left justified
 OFORM = Low: LSB first, right justified

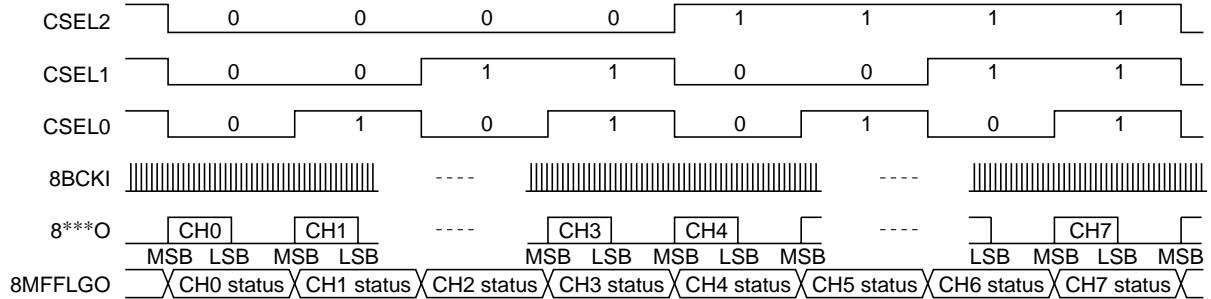

OFORM (MSB first, left justified)

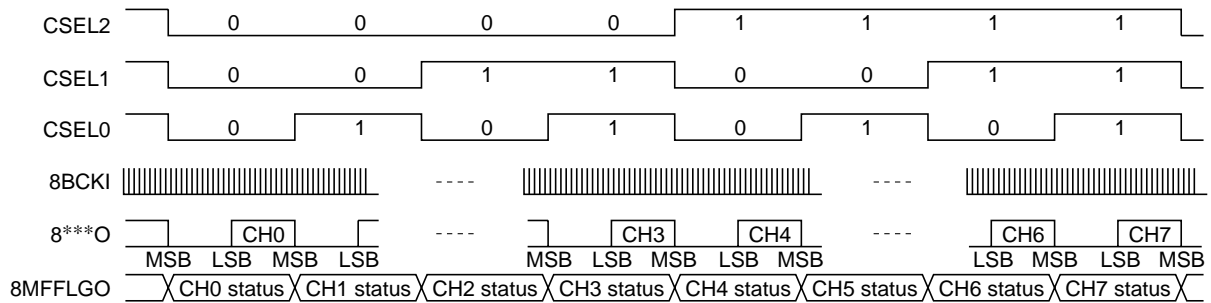

OFORM (LSB first, right justified)

- MaxPeak (ANNEX D3)**
- HF RMS (ANNEX D4)**
- MF (ANNEX E2)**
- MF Status Flags (ANNEX E2)**
- LF**
- DC (ANNEX E4)**

See 1-3.

Package Outline

Unit: mm

208PIN QFP (PLASTIC)

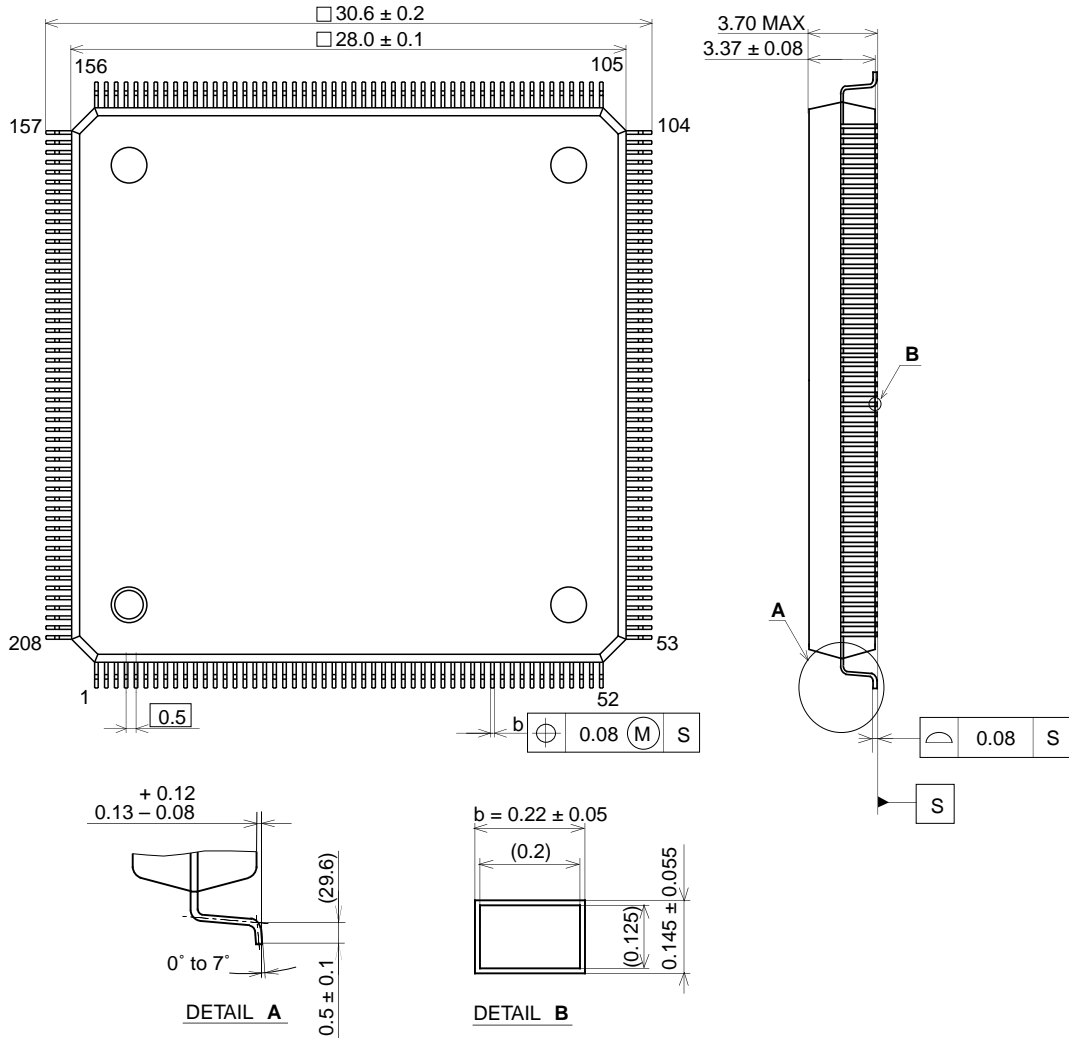

PACKAGE STRUCTURE

PACKAGE MATERIAL	EPOXY RESIN
LEAD TREATMENT	SOLDER PLATING
LEAD MATERIAL	COPPER ALLOY
PACKAGE MASS	4.9g

SONY CODE	QFP-208P-L281
EIAJ CODE	P-QFP208-28X28-0.5
JEDEC CODE	_____

LEAD PLATING SPECIFICATIONS

ITEM	SPEC.
LEAD MATERIAL	COPPER ALLOY
SOLDER COMPOSITION	Sn-Bi Bi:1-4wt%
PLATING THICKNESS	5-18μm



LittleDiode supplies new, hard to find or obsolete electronic components and semiconductors all over the world.

With over two million different components listed you are sure to find the part you need.

Feel free to visit us today at our online store:

LittleDiode.com

Looking forward to providing you with the best possible service.