

CD Digital Signal Processor with Built-in Digital Servo and DAC

Description

The CXD2588Q/R is a digital signal processor LSI for CD players. This LSI incorporates a digital servo, digital filter, zero detection circuit, 1-bit DAC and analog low-pass filter on a single chip.

Features

- Digital Signal Processor (DSP) Block
- Playback mode which supports CAV (Constant Angular Velocity)
 - Frame jitter free
 - 0.5× to 4× continuous playback possible
 - Allows relative rotational velocity readout
 - Supports spindle external control
 - Wide capture range playback mode
 - Spindle rotational velocity following method
 - Supports normal-speed, 4× speed playback
 - 16K RAM
 - EFM data demodulation
 - Enhanced EFM frame sync signal protection
 - SEC strategy-based error correction
 - Subcode demodulation and Sub Q data error detection
 - Digital spindle servo
 - 16-bit traverse counter
 - Asymmetry compensation circuit
 - CPU interface on serial bus
 - Error correction monitor signal, etc. output from a new CPU interface
 - Servo auto sequencer
 - Digital audio interface outputs
 - Digital level meter, peak meter
 - CD TEXT data demodulation

Digital Servo (DSSP) Block

- Microcomputer software-based flexible servo control
- Offset cancel function for servo error signal
- Auto gain control function for servo loop
- E:F balance, focus bias adjustment functions
- Surf jump function supporting micro two-axis

Digital Filter, DAC and Analog Low-Pass Filter Blocks

- DBB (digital bass boost) function
- Double-speed playback supported
- Digital de-emphasis
- Digital attenuation
- Zero detection function
- 8Fs oversampling digital filter
- S/N: 100dB or more (master clock: 384Fs, typ.)
- Logical value: 109dB
- THD + N: 0.007% or less (master clock: 384Fs, typ.)
- Rejection band attenuation: -60dB or less

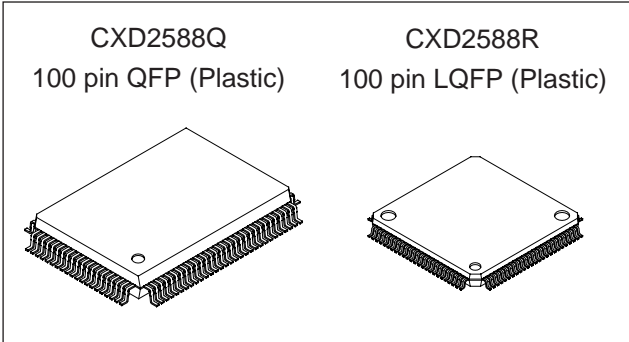

Applications

CD players

Structure

Silicon gate CMOS IC

Absolute Maximum Ratings

- Supply voltage V_{DD} -0.3 to +7.0 V
- Input voltage V_I -0.3 to +7.0 V
($V_{SS} - 0.3V$ to $V_{DD} + 0.3$)
- Output voltage V_O -0.3 to +7.0 V
- Storage temperature T_{stg} -40 to +125 °C
- Supply voltage difference
 - $V_{SS} - AV_{SS}$ -0.3 to +0.3 V
 - $V_{DD} - AV_{DD}$ -0.3 to +0.3 V

Recommended Operating Conditions

- Supply voltage $V_{DD}^{(Note)}$ +2.7 to +5.5 V
- Operating temperature T_{opr} -20 to +75 °C

Note) The V_{DD} for the CXD2588Q/R varies according to the playback speed selection.

Playback speed	V_{DD} [V]	
	CD-DSP block	DAC block
4×	4.75 to 5.25	/
1×	3.0 to 5.5	4.5 to 5.5
1×	2.7 to 5.5	2.7 to 5.5

I/O Capacitance

- Input pin C_I 11 (Max.) pF
- Output pin C_O 11 (Max.) pF
- I/O pin $C_{I/O}$ 11 (Max.) pF

Note) Measurement conditions $V_{DD} = V_I = 0V$
 $f_M = 1MHz$

Sony reserves the right to change products and specifications without prior notice. This information does not convey any license by any implication or otherwise under any patents or other right. Application circuits shown, if any, are typical examples illustrating the operation of the devices. Sony cannot assume responsibility for any problems arising out of the use of these circuits.

Block Diagram

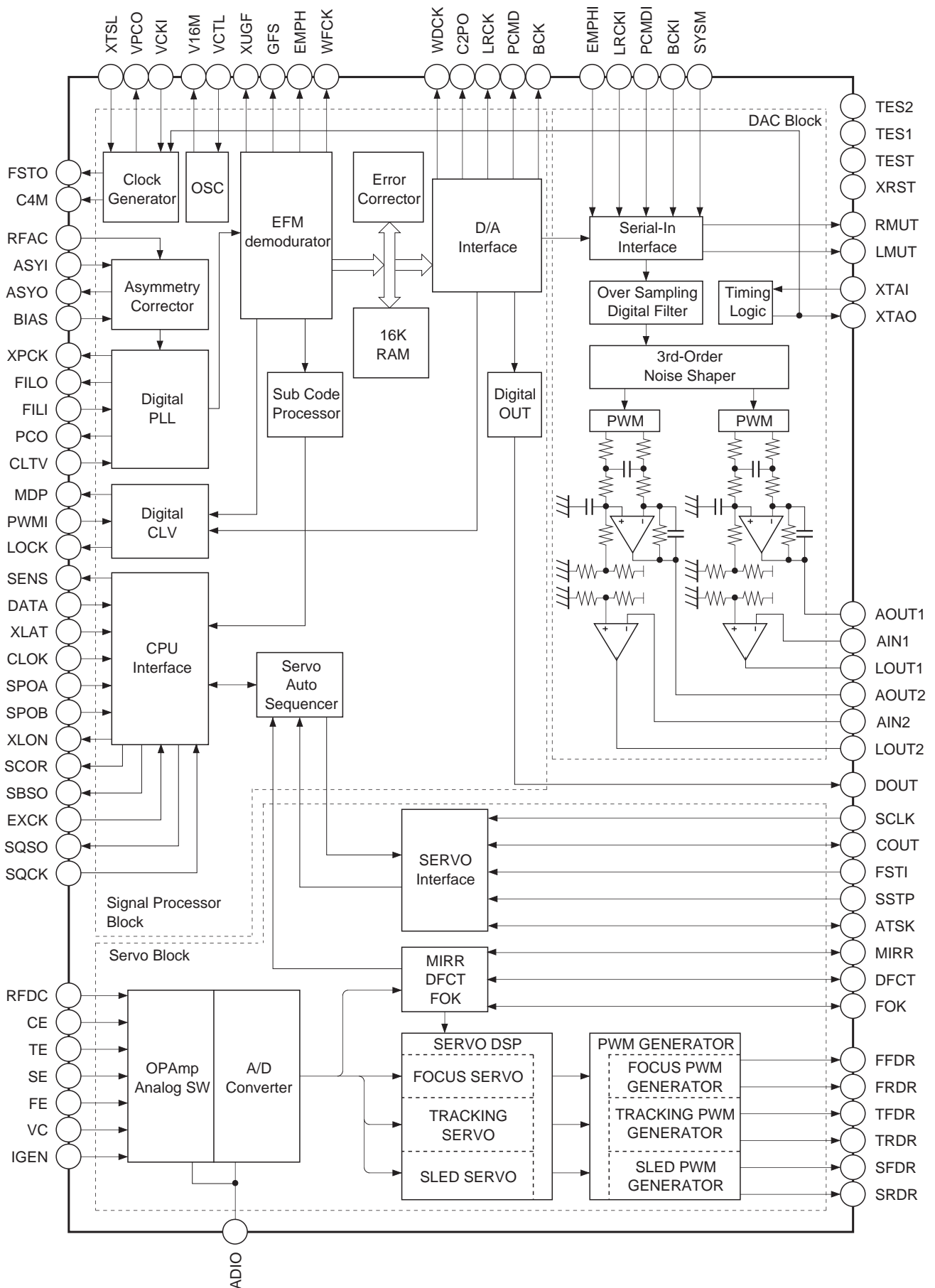

Pin Configuration (CXD2588Q)



Pin Configuration (CXD2588R)

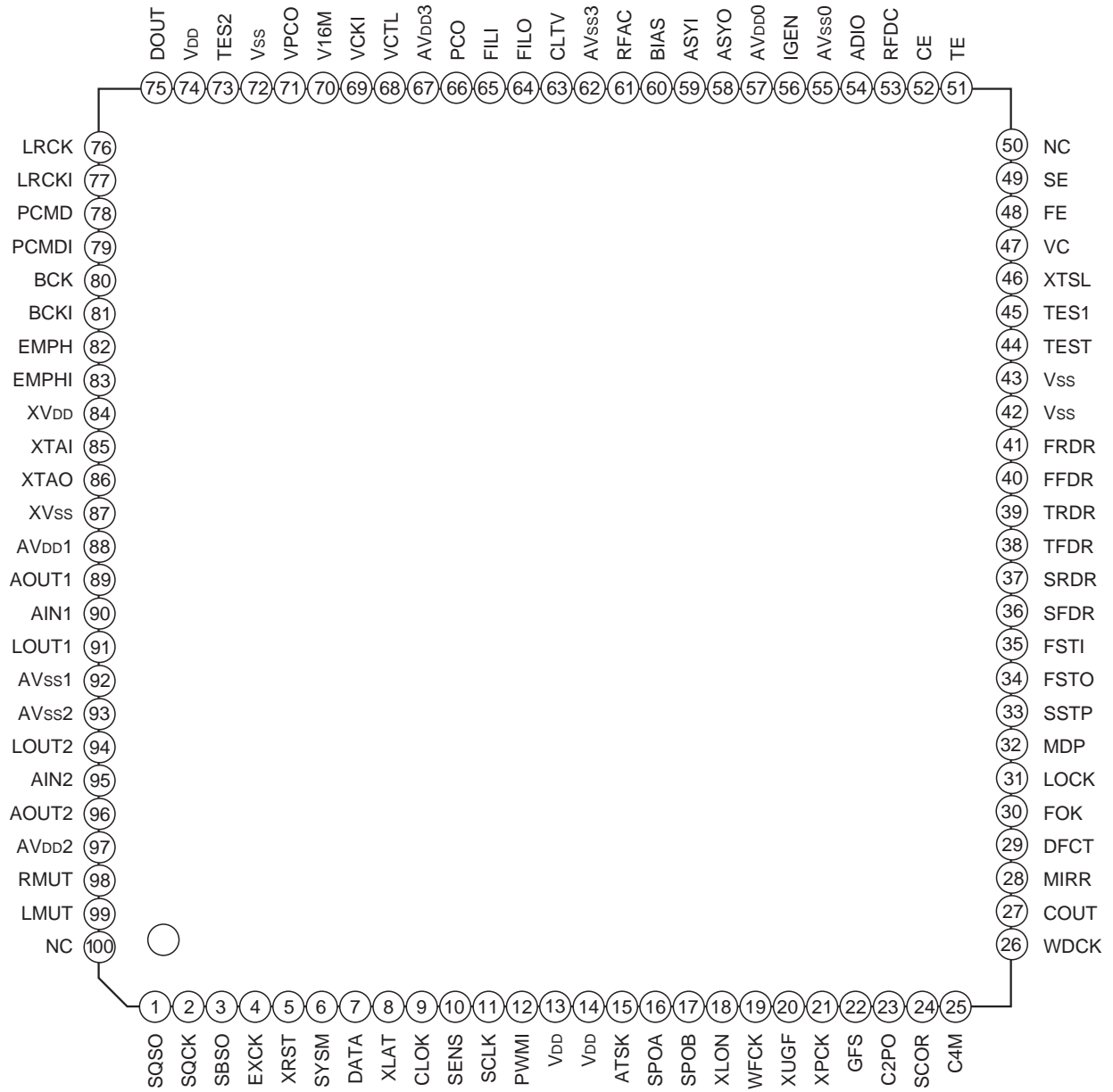

Pin Description

Pin No.		Symbol	I/O	Output values	Description
CXD 2588R	CXD 2588Q				
1	3	SQSO	O	1, 0	Sub Q 80-bit, PCM peak and level data outputs. CD TEXT data output.
2	4	SQCK	I		SQSO readout clock input.
3	5	SBSO	O	1, 0	Sub Q P to W serial output.
4	6	EXCK	I		SBSO readout clock input.
5	7	XRST	I		System reset. Reset when low.
6	8	YSM	I		Mute input. Muted when high.
7	9	DATA	I		Serial data input from CPU.
8	10	XLAT	I		Latch input from CPU. Serial data is latched at the falling edge.
9	11	CLOK	I		Serial data transfer clock input from CPU.
10	12	SENS	O	1, 0	SENS output to CPU.
11	13	SCLK	I		SENS serial data readout clock input.
12	14	PWMI	I		Spindle motor external control input.
13	15	V _{DD}	—	—	Digital power supply.
14	16	V _{DD}	—	—	Digital power supply.
15	17	ATSK	I/O	1, 0	Anti-shock input/output.
16	18	SPOA	I		Microcomputer extension interface (input A)
17	19	SPOB	I		Microcomputer extension interface (input B)
18	20	XLON	O	1, 0	Microcomputer extension interface (output)
19	21	WFCK	O	1, 0	WFCK output.
20	22	XUGF	O	1, 0	XUGF output. MINT1 or RFCK is output by switching with the command.
21	23	XPCK	O	1, 0	XPCK output. MNT0 is output by switching with the command.
22	24	GFS	O	1, 0	GFS output. MNT3 or XROF is output by switching with the command.
23	25	C2PO	O	1, 0	C2PO output. GTOP is output by switching with the command.
24	26	SCOR	O	1, 0	Outputs a high signal when either subcode sync S0 or S1 is detected.
25	27	C4M	O	1, 0	4.2336MHz output. In CAV-W mode, 1/4 frequency division output for VCKI.
26	28	WDCK	O	1, 0	Word clock output. $f = 2Fs$.
27	29	COUT	I/O	1, 0	Track count signal input/output.
28	30	MIRR	I/O	1, 0	Mirror signal input/output.
29	31	DFCT	I/O	1, 0	Defect signal input/output.
30	32	FOK	I/O	1, 0	Focus OK signal input/output.
31	33	LOCK	I/O	1, 0	GFS is sampled at 460Hz; when GFS is high, this pin outputs a high signal. If GFS is low eight consecutive samples, this pin outputs low. Or input when LKIN = 1.
32	34	MDP	O	1, Z, 0	Spindle motor servo control output.
33	35	SSTP	I		Disc innermost track detection signal input.
34	36	FSTO	O	1, 0	2/3 frequency division output for XTAL pin.

Pin No.		Symbol	I/O	Output values	Description
CXD 2588R	CXD 2588Q				
35	37	FSTI	I		2/3 frequency division input for XTAL pin.
36	38	SFDR	O	1, 0	Sled drive output.
37	39	SRDR	O	1, 0	Sled drive output.
38	40	TFDR	O	1, 0	Tracking drive output.
39	41	TRDR	O	1, 0	Tracking drive output.
40	42	FFDR	O	1, 0	Focus drive output.
41	43	FRDR	O	1, 0	Focus drive output.
42	44	Vss	—	—	Digital GND.
43	45	Vss	—	—	Digital GND.
44	46	TEST	I		Test pin. Normally, GND.
45	47	TES1	I		Test pin. Normally, GND.
46	48	XTSL	I		Crystal selection input. Low when the crystal is 16.9344MHz; high when the crystal is 33.8688MHz.
47	49	VC	I		Center voltage input.
48	50	FE	I		Focus error signal input.
49	51	SE	I		Sled error signal input.
50	52	NC			
51	53	TE	I		Tracking error signal input.
52	54	CE	I		Center servo analog input.
53	55	RFDC	I		RF signal input.
54	56	ADIO	O	Analog	Test pin. No connected.
55	57	AVss0	—	—	Analog GND.
56	58	IGEN	I		Operational amplifier constant current input.
57	59	AVDD0	—	—	Analog power supply.
58	60	ASYO	O	1, 0	EFM full-swing output. (low = Vss, high = VDD)
59	61	ASYI	I		Asymmetry comparator voltage input.
60	62	BIAS	I		Asymmetry circuit constant current input.
61	63	RFAC	I		EFM signal input.
62	64	AVss3	—	—	Analog GND.
63	65	CLTV	I		Multiplier VCO1 control voltage input.
64	66	FILO	O	Analog	Master PLL filter output. (slave = digital PLL)
65	67	FILI	I		Master PLL filter input.
66	68	PCO	O	1, Z, 0	Master PLL charge pump output.
67	69	AVDD3	—	—	Analog power supply.
68	70	VCTL	I		Wide-band EFM PLL VCO2 control voltage input.
69	71	VCKI	I		Wide-band EFM PLL VCO2 oscillation input.

Pin No.		Symbol	I/O	Output values	Description
CXD 2588R	CXD 2588Q				
70	72	V16M	O	1, 0	Wide-band EFM PLL VCO2 oscillation output.
71	73	VPCO	O	1, Z, 0	Wide-band EFM PLL charge pump output.
72	74	V _{SS}	—	—	Digital GND.
73	75	TES2	I		Test pin. Normally GND.
74	76	V _{DD}	—	—	Digital power supply.
75	77	DOUT	O	1, 0	Digital Out output.
76	78	LRCK	O	1, 0	D/A interface. LR clock output f = Fs.
77	79	KRCKI	I		D/A interface. LR clock input.
78	80	PCMD	O	1, 0	D/A interface. Serial data output. (two's complement, MSB first)
79	81	PCMDI	I		D/A interface. Serial data input. (two's complement, MSB first)
80	82	BCK	O	1, 0	D/A interface. Bit clock output.
81	83	BCKI	I		D/A interface. Bit clock input.
82	84	EMPH	O	1, 0	Outputs a high signal when the playback disc has emphasis, and a low signal when there is no emphasis.
83	85	EMPHI	I		Inputs a high signal when de-emphasis is on, and a low signal when de-emphasis is off.
84	86	XV _{DD}	—	—	Master clock power supply.
85	87	XTAI	I		Crystal oscillation circuit input. Master clock is externally input from this pin.
86	88	XTAO	O		Crystal oscillation circuit output.
87	89	XV _{SS}	—	—	Master clock GND.
88	90	AV _{DD1}	—	—	Analog power supply.
89	91	AOUT1	O		L ch analog output.
90	92	AIN1	I		L ch operational amplifier input.
91	93	LOUT1	O		L ch LINE output.
92	94	AV _{SS1}	—	—	Analog GND.
93	95	AV _{SS2}	—	—	Analog GND.
94	96	LOUT2	O		R ch LINE output.
95	97	AIN2	I		R ch operational amplifier output.
96	98	AOUT2	O		R ch analog output.
97	99	AV _{DD2}	—	—	Analog power supply.
98	100	RMUT	O	1, 0	R ch zero detection flag.
99	1	LMUT	O	1, 0	L ch zero detection flag.
100	2	NC			

- Notes)**
- PCMD is a MSB first, two's complement output.
 - GTOP is used to monitor the frame sync protection status. (High: sync protection window released.)
 - XUGF is the frame sync obtained from the EFM signal, and is negative pulse. It is the signal before sync protection.
 - XPCK is the inverse of the EFM PLL clock. The PLL is designed so that the falling edge and the EFM signal transition point coincide.
 - The GFS signal goes high when the frame sync and the insertion timing match.
 - RFCK is derived from the crystal accuracy, and has a cycle of 136 μ s.
 - C2PO represents the data error status.
 - XROF is generated when the 16K RAM exceeds the $\pm 4F$ jitter margin.

Monitor Pin Output Combinations

Command bit		Output data			
MTSL1	MTSL0				
0	0	XUGF	XPCK	GFS	C2PO
0	1	MNT1	MNT0	MNT3	C2PO
1	0	RFCK	XPCK	XROF	GTOP

Electrical Characteristics

1. DC Characteristics

(V_{DD} = AV_{DD} = 5.0V ± 5%, V_{SS} = AV_{SS} = 0V, Topr = -20 to +75°C)

Item		Conditions	Min.	Typ.	Max.	Unit	Applicable pins	
Input voltage (1)	High level input voltage	V _{IH} (1)	0.7V _{DD}			V	*1, *11	
	Low level input voltage	V _{IL} (1)			0.3V _{DD}	V		
Input voltage (2)	High level input voltage	V _{IH} (2)	0.8V _{DD}			V	*2, *12	
	Low level input voltage	V _{IL} (2)				0.2V _{DD}		V
Input voltage (3)	High level input voltage	V _{IH} (3)	0.8V _{DD}			V	*3	
	Low level input voltage	V _{IL} (3)				0.2V _{DD}		V
Input voltage (4)	Input voltage	V _{IN} (4)	Analog input	V _{SS}		V _{DD}	V	*4, *9, *10
Output Voltage (1)	High level output voltage	V _{OH} (1)	I _{OH} = -2mA	V _{DD} - 0.8		V _{DD}	V	*5
	Low level output voltage	V _{OL} (1)	I _{OL} = 4mA	V _{SS}		0.4	V	
Output Voltage (2)	High level output voltage	V _{OH} (2)	I _{OH} = -4mA	V _{DD} - 0.8		V _{DD}	V	*6
	Low level output voltage	V _{OL} (2)	I _{OL} = 8mA	V _{SS}		0.4	V	
Output Voltage (3)	High level output voltage	V _{OH} (3)	I _{OH} = -6mA	V _{DD} - 0.8		V _{DD}	V	*7
	Low level output voltage	V _{OL} (3)	I _{OL} = 4mA	V _{SS}		0.4	V	
Output Voltage (4)	High level output voltage	V _{OH} (4)	I _{OH} = -0.28mA	V _{DD} - 0.5		V _{DD}	V	*8
	Low level output voltage	V _{OL} (4)	I _{OL} = 0.36mA	V _{SS}		0.4	V	
Input leak current (1)		I _{LI} (1)	V _{IN} = V _{SS} or V _{DD}	-10		10	μA	*1, *2
Input leak current (2)		I _{LI} (2)	V _{IN} = V _{SS} or V _{DD}	-40		40	μA	*11, *12
Input leak current (3)		I _{LI} (3)	V _I = 1.5 to 3.5V	-20		20	μA	*9
Input leak current (4)		I _{LI} (4)	V _I = 0 to 5.0V	-40		600	μA	*10

Applicable pins

*1 SYSM, DATA, XLAT, PWMI, SSTP, FSTI, XTSL, TEST, TES1, VCKI, TES2

*2 SQCK, XRST, CLOK

*3 LRCKI, PCMDI, BCKI, EMPHI

*4 ASYI, RFAC, CLTV, FILI, VCTL

*5 SQSO, SBSO, SENS, ATSK, XLON, WFCK, XUGF, XPCK, GFS, C2PO, SCOR, C4M, WDCK, COUT, MIRR, DFCT, FOK, LOCK, FSTO, SFDR, SRDR, TFDR, TRDR, FFDR, FRDR, ASYO, DOUT, LRCK, PCMD, BCK, EMPH, RMUT, LMUT

*6 V16M

*7 MDP, PCO, VPCO

*8 FILO

*9 VC, FE, SE, TE, CE

*10 RFDC

*11 EXCK, ATSK, COUT, MIRR, DFCT, FOK, LOCK

*12 SCLK, SPOA, SPOB

2. AC Characteristics

(1) XTAI pin

(a) When using self-excited oscillation

($T_{opr} = -20$ to $+75^{\circ}\text{C}$, $V_{DD} = AV_{DD} = 5.0\text{V} \pm 5\%$)

Item	Symbol	Min.	Typ.	Max.	Unit
Oscillation frequency	f_{MAX}	7		34	MHz

(b) When inputting pulses to XTAI pin

($T_{opr} = -20$ to $+75^{\circ}\text{C}$, $V_{DD} = AV_{DD} = 5.0\text{V} \pm 5\%$)

Item	Symbol	Min.	Typ.	Max.	Unit
High level pulse width	t_{WHX}	13		500	ns
Low level pulse width	t_{WLX}	13		500	ns
Pulse cycle	t_{CK}	26		1,000	ns
Input high level	V_{IHx}	$V_{DD} - 1.0$			V
Input low level	V_{ILx}			0.8	V
Rise time, fall time	t_R, t_F			10	ns

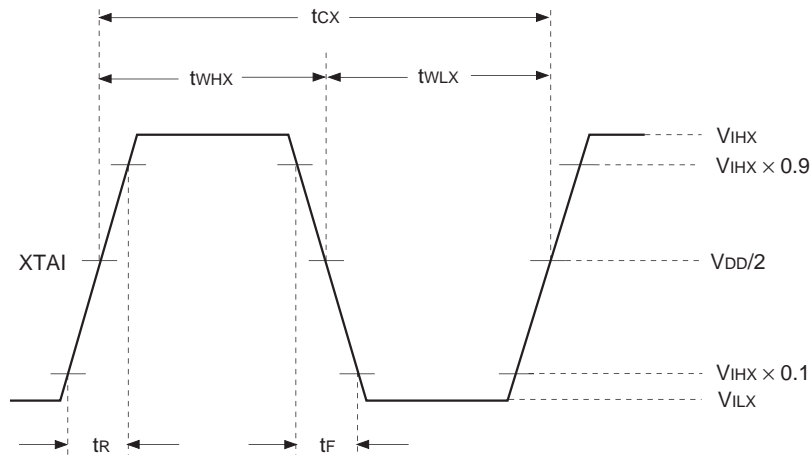

(c) When inputting sine waves to XTAI pin via a capacitor

($T_{opr} = -20$ to $+75^{\circ}\text{C}$, $V_{DD} = AV_{DD} = 5.0\text{V} \pm 5\%$)

Item	Symbol	Min.	Typ.	Max.	Unit
Input amplitude	V_i	2.0		$V_{DD} + 0.3$	Vp-p

(2) CLOK, DATA, XLAT, COUT, SQCK, and EXCK pins
 ($V_{DD} = AV_{DD} = 5.0V \pm 5\%$, $V_{SS} = AV_{SS} = 0V$, $T_{opr} = -20$ to $+75^{\circ}C$)

Item	Symbol	Min.	Typ.	Max.	Unit
Clock frequency	f _{ck}			0.65	MHz
Clock pulse width	t _{wck}	750			ns
Setup time	t _{su}	300			ns
Hold time	t _h	300			ns
Delay time	t _d	300			ns
Latch pulse width	t _{wl}	750			ns
EXCK, SQCK frequency	f _t			0.65 ^{Note)}	MHz
EXCK, SQCK pulse width	f _{wT}	750 ^{Note)}			ns

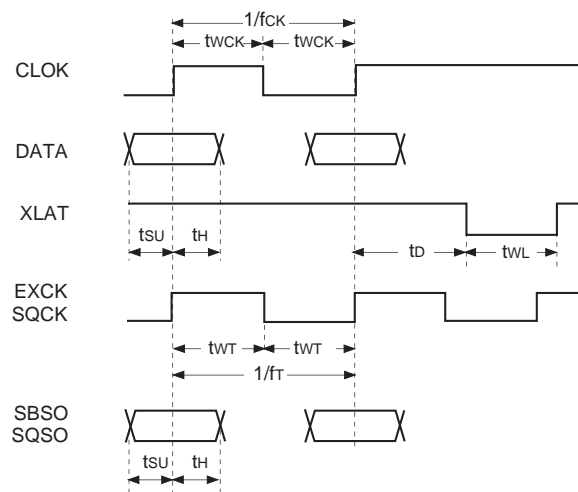

Note) In quasi double-speed playback mode, except when SQSO is Sub Q Read, the SQCK maximum operating frequency is 300kHz and its minimum pulse width is 1.5 μ s.

(3) BCKI, LRCKI and PCMDI pins ($V_{DD} = AV_{DD} = 5.0V \pm 5\%$, $V_{SS} = AV_{SS} = 0V$, $T_{opr} = -20$ to $+75^{\circ}C$)

Item	Symbol	Conditions	Min.	Typ.	Max.	Unit
BCK pulse width	t _w		94			ns
DATAL, R setup time	t _{su}		18			ns
DATAL, R hold time	t _h		18			ns
LRCK setup time	t _{su}		18			ns

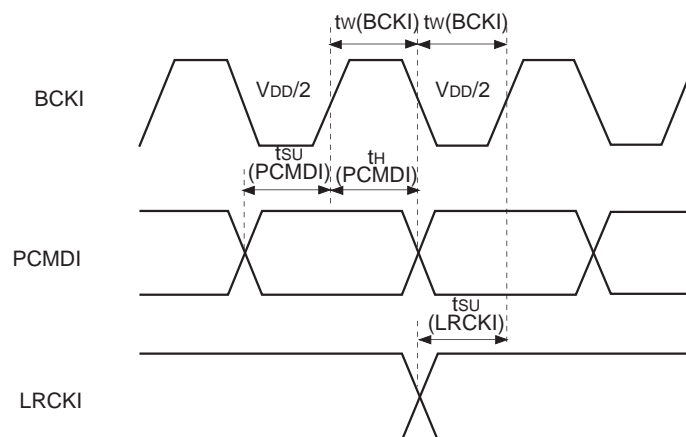

(4) SCLK pin

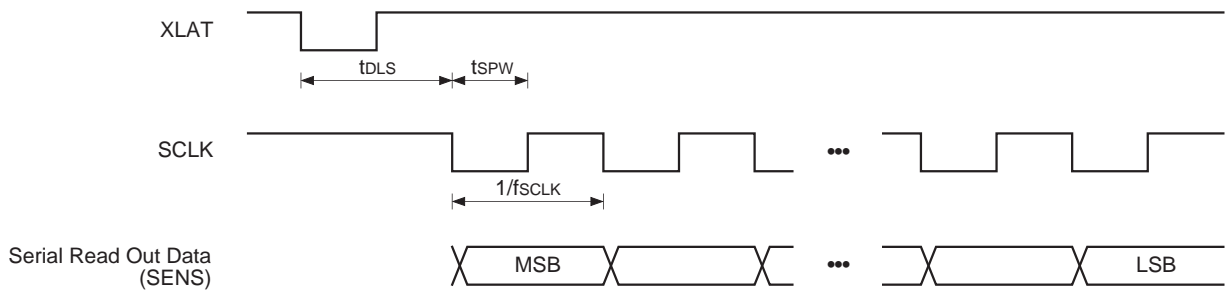

Item	Symbol	Min.	Typ.	Max.	Unit
SCLK frequency	f _{SCLK}			16	MHz
SCLK pulse width	t _{SPW}	31.3			ns
Delay time	t _{DLS}	15			μs

(5) COUT, MIRR and DFCT pins

Operating frequency (V_{DD} = AV_{DD} = 5.0V ± 5%, V_{SS} = AV_{SS} = 0V, Topr = -20 to +75°C)

Item	Symbol	Min.	Typ.	Max.	Unit	Conditions
COUT maximum operating frequency	f _{COUT}	40			kHz	*1
MIRR maximum operating frequency	f _{MIRR}	40			kHz	*2
DFCT maximum operating frequency	f _{DFCTH}	5			kHz	*3

*1 When using a high-speed traverse TZC

*2

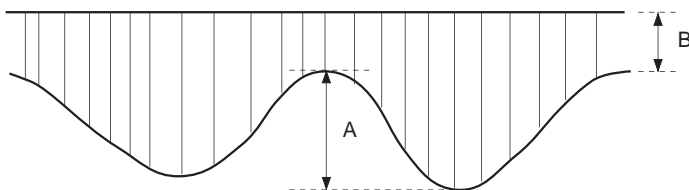

When the RF signal continuously satisfies the following conditions during the above traverse.

- $A = 0.12V_{DD}$ to $0.26V_{DD}$

- $\frac{B}{A + B} = 25\%$

*3 During complete RF signal omission

When settings related to DFCT signal generation are Typ.

1-bit DAC and LPF Block Analog Characteristics

Analog characteristics ($V_{DD} = AV_{DD} = 5.0V$, $V_{SS} = AV_{SS} = 0V$, $T_a = 25^{\circ}C$)

Item	Symbol	Conditions	Crystal	Min.	Typ.	Max.	Unit
Total harmonic distortion	THD	1kHz, 0dB data	384Fs		0.0050	0.0070	%
			768Fs		0.0045	0.0065	
Signal-to-noise ratio	S/N	1kHz, 0dB data (Using A-weighting filter)	384Fs	96	100		dB
			768Fs	96	100		

Fs = 44.1kHz in all cases.

The total harmonic distortion and signal-to-noise ratio measurement circuits are shown below.

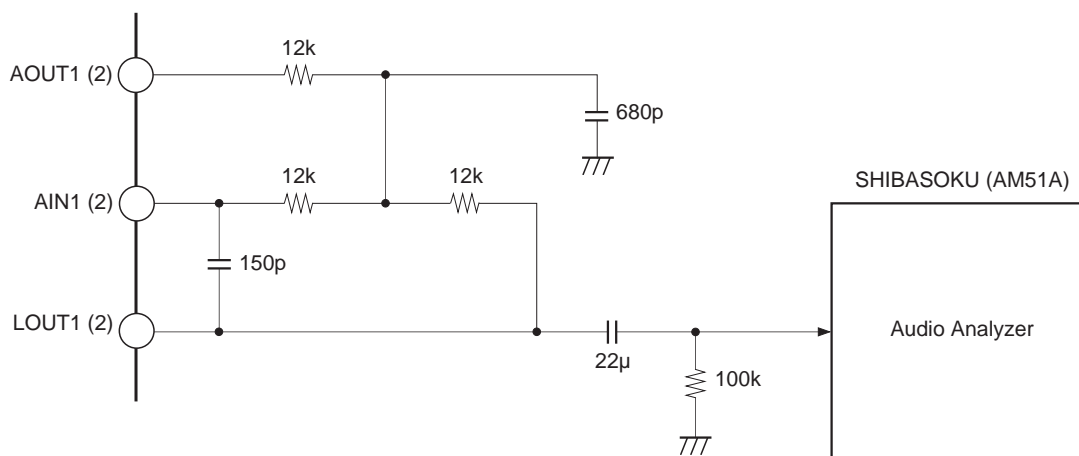

LPF external circuit diagram

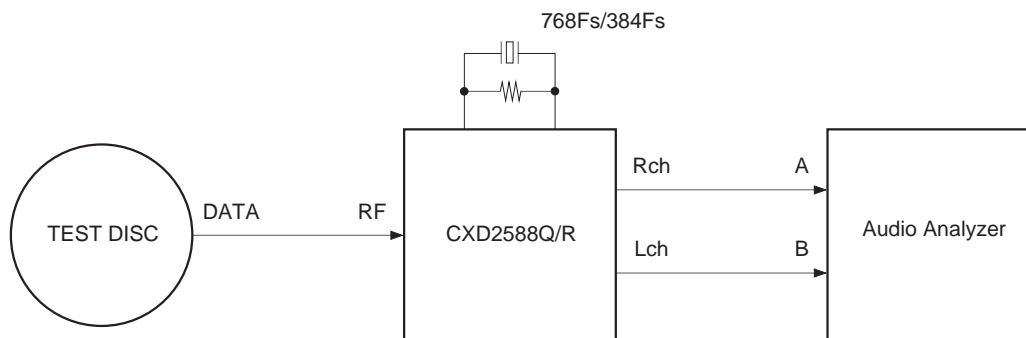

Block diagram of analog characteristics measurement

($V_{DD} = AV_{DD} = 5.0V$, $V_{SS} = AV_{SS} = 0V$, $T_{opr} = -20$ to $+75^{\circ}C$)

Item	Symbol	Min.	Typ.	Max.	Unit	Applicable pins
Output voltage	V_{OUT}		1.12		V _{rms}	*1
Load resistance	R_L	8			k Ω	*1

* Measurement is conducted for the LPF external circuit diagram with the sine wave output of 1kHz and 0dB.

Applicable pins

*1 LOUT1, LOUT2

Contents

§1. CPU Interface	
§1-1. CPU Interface Timing	16
§1-2. CPU Interface Command Table	16
§1-3. CPU Command Presets	26
§1-4. Description of SENS Signals and Commands	31
§2. Subcode Interface	
§2-1. P to W Subcode Readout	51
§2-2. 80-bit Sub Q Readout	51
§3. Description of Modes	
§3-1. CLV-N Mode	56
§3-2. CLV-W Mode	56
§3-3. CAV-W Mode	56
§4. Description of Other Functions	
§4-1. Channel Clock Regeneration by the Digital PLL Circuit	58
§4-2. Frame Sync Protection	60
§4-3. Error Correction	60
§4-4. DA Interface	61
§4-5. Digital Out	63
§4-6. Servo Auto Sequence	63
§4-7. Digital CLV	70
§4-8. CD-DSP Block Playback Speed	71
§4-9. DAC Block Playback Speed	71
§4-10. DAC Block Input Timing	72
§4-11. Description of DAC Block Functions	72
§4-12. LPF Block	76
§4-13. Asymmetry Compensation	77
§4-14. CD Text Data Demodulation	78
§5. Description of Servo Signal Processing System Functions and Commands	
§5-1. General Description of Servo Signal Processing System	80
§5-2. Digital Servo Block Master Clock (MCK)	81
§5-3. AVRГ Measurement and Compensation	81
§5-4. E:F Balance Adjustment Function	83
§5-5. FCS Bias Adjustment Function	83
§5-6. AGCNTL Function	85
§5-7. FCS Servo and FCS Search	87
§5-8. TRK and SLD Servo Control	88
§5-9. MIRR and DFCT Signal Generation	89
§5-10. DFCT Countermeasure Circuit	90
§5-11. Anti-Shock Circuit	90
§5-12. Brake Circuit	91
§5-13. COUT Signal	92
§5-14. Serial Readout Circuit	92
§5-15. Writing to the Coefficient RAM	93
§5-16. PWM Output	93
§5-17. Servo Status Changes Produced by the LOCK Signal	95
§5-18. Description of Commands and Data Sets	95
§5-19. List of Servo Filter Coefficients	110
§5-20. Filter Composition	112
§5-21. TRACKING and FOCUS Frequency Response	119
§6. Application Circuit	120

Explanation of abbreviations	AVRG: Average
	AGCNTL: Auto gain control
	FCS: Focus
	TRK: Tracking
	SLD: Sled
	DFCT: Defect

§1. CPU Interface

§1-1. CPU Interface Timing

• CPU interface

This interface uses DATA, CLOK and XLAT to set the modes.

The interface timing chart is shown below.

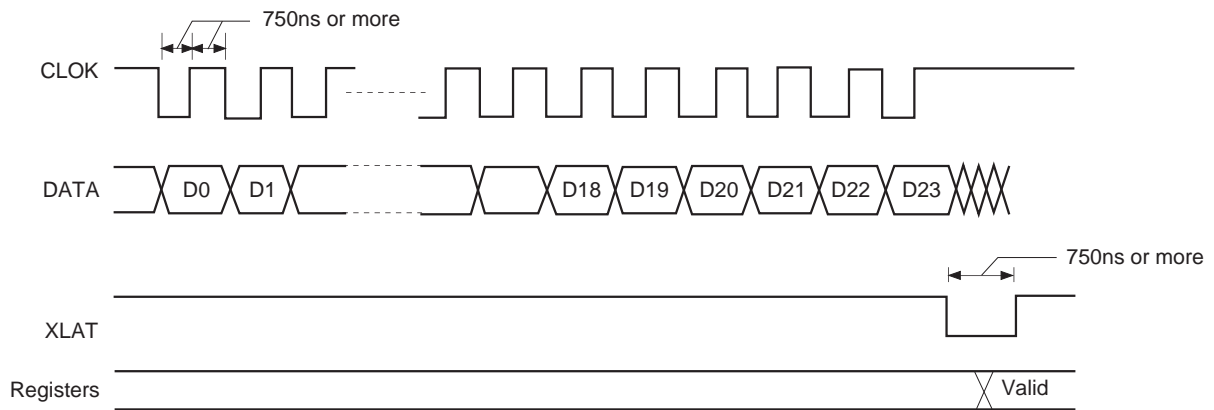

- The internal registers are initialized by a reset when XRST = 0.

Note) Be sure to set SQCK to high when XLAT is low.

§1-2. CPU Interface Command Table

Total bit length for each register

Register	Total bit length
0 to 2	8 bits
3	8 to 24 bits
4 to 6	8 bits
7	20 bits
8	28 bits
9	24 bits
A	28 bits
B	16 bits
C	8 bits
D	16 bits
E	20 bits

Command Table (\$2X to 3X)

Register	Command	Address																				
		Data 1				Data 2				Data 3				Data 4				Data 5				
		D19	D18	D17	D16	D15	D14	D13	D12	D11	D10	D9	D8	D7	D6	D5	D4	D3	D2	D1	D0	
2	TRACKING MODE	0	0	—	—	—	—	—	—	—	—	—	—	—	—	—	—	—	—	—	—	TRACKING SERVO OFF
		0	1	—	—	—	—	—	—	—	—	—	—	—	—	—	—	—	—	—	—	TRACKING SERVO ON
		1	0	—	—	—	—	—	—	—	—	—	—	—	—	—	—	—	—	—	—	FORWARD TRACK JUMP
		1	1	—	—	—	—	—	—	—	—	—	—	—	—	—	—	—	—	—	—	REVERSE TRACK JUMP
		—	—	0	0	—	—	—	—	—	—	—	—	—	—	—	—	—	—	—	—	SLED SERVO OFF
		—	—	0	1	—	—	—	—	—	—	—	—	—	—	—	—	—	—	—	—	SLED SERVO ON
		—	—	1	0	—	—	—	—	—	—	—	—	—	—	—	—	—	—	—	—	FORWARD SLED MOVE
		—	—	1	1	—	—	—	—	—	—	—	—	—	—	—	—	—	—	—	—	REVERSE SLED MOVE
3	SELECT	Address																				
		D23 to D20																				
		D19																				
		D18																				
		D17																				
		0	0	0	0	—	—	—	—	—	—	—	—	—	—	—	—	—	—	—	—	SLED KICK LEVEL (±1 × basic value) (Default)
		0	0	0	1	—	—	—	—	—	—	—	—	—	—	—	—	—	—	—	—	SLED KICK LEVEL (±2 × basic value)
		0	0	1	0	—	—	—	—	—	—	—	—	—	—	—	—	—	—	—	—	SLED KICK LEVEL (±3 × basic value)
		0	0	1	1	—	—	—	—	—	—	—	—	—	—	—	—	—	—	—	—	SLED KICK LEVEL (±4 × basic value)

—: Don't care

Command Table (\$340X)

Register	Command	Address 1		Address 2		Address 3		Address 4			Data 1				Data 2							
		D23 to D20	D19 to D16	D15 to D12	D11	D10	D9	D8	D7	D6	D5	D4	D3	D2	D1	D0						
3	SELECT	0 0 1 1	0 1 0 0	0 0 0 0	0	0	0	0	0	KD7	KD6	KD5	KD4	KD3	KD2	KD1	KD0	KRAM DATA (K00) SLED INPUT GAIN				
					0	0	1	0	0	0	0	0	KD7	KD6	KD5	KD4	KD3	KD2	KD1	KD0	KRAM DATA (K01) SLED LOW BOOST FILTER A-H	
					0	0	1	0	0	1	0	0	0	KD7	KD6	KD5	KD4	KD3	KD2	KD1	KD0	KRAM DATA (K02) SLED LOW BOOST FILTER A-L
					0	0	1	0	0	1	1	0	0	KD7	KD6	KD5	KD4	KD3	KD2	KD1	KD0	KRAM DATA (K03) SLED LOW BOOST FILTER B-H
					0	1	0	0	1	0	0	0	0	KD7	KD6	KD5	KD4	KD3	KD2	KD1	KD0	KRAM DATA (K04) SLED LOW BOOST FILTER B-L
					0	1	0	1	0	0	1	0	0	KD7	KD6	KD5	KD4	KD3	KD2	KD1	KD0	KRAM DATA (K05) SLED OUTPUT GAIN
					0	1	1	0	1	0	0	0	0	KD7	KD6	KD5	KD4	KD3	KD2	KD1	KD0	KRAM DATA (K06) FOCUS INPUT GAIN
					0	1	1	1	0	0	1	0	0	KD7	KD6	KD5	KD4	KD3	KD2	KD1	KD0	KRAM DATA (K07) SLED AUTO GAIN
					1	0	0	0	0	0	0	0	0	KD7	KD6	KD5	KD4	KD3	KD2	KD1	KD0	KRAM DATA (K08) FOCUS HIGH CUT FILTER A
					1	0	0	1	0	0	1	0	0	KD7	KD6	KD5	KD4	KD3	KD2	KD1	KD0	KRAM DATA (K09) FOCUS HIGH CUT FILTER B
					1	0	1	0	1	0	0	0	0	KD7	KD6	KD5	KD4	KD3	KD2	KD1	KD0	KRAM DATA (K0A) FOCUS LOW BOOST FILTER A-H
					1	0	1	1	1	0	1	0	0	KD7	KD6	KD5	KD4	KD3	KD2	KD1	KD0	KRAM DATA (K0B) FOCUS LOW BOOST FILTER A-L
					1	1	0	0	0	0	0	0	0	KD7	KD6	KD5	KD4	KD3	KD2	KD1	KD0	KRAM DATA (K0C) FOCUS LOW BOOST FILTER B-H
					1	1	0	1	0	1	0	1	0	KD7	KD6	KD5	KD4	KD3	KD2	KD1	KD0	KRAM DATA (K0D) FOCUS LOW BOOST FILTER B-L
					1	1	1	1	0	1	0	0	0	KD7	KD6	KD5	KD4	KD3	KD2	KD1	KD0	KRAM DATA (K0E) FOCUS PHASE COMPENSATE FILTER A
					1	1	1	1	1	1	1	1	1	KD7	KD6	KD5	KD4	KD3	KD2	KD1	KD0	KRAM DATA (K0F) FOCUS DEFECT HOLD GAIN

Command Table (\$342X)

Register	Command	Address 1		Address 2		Address 3		Address 4			Data 1				Data 2					
		D23 to D20		D19 to D16		D15 to D12		D11	D10	D9	D8	D7	D6	D5	D4	D3	D2	D1		D0
3	SELECT	0011		0100		0010		0	0	0	0	KD7	KD6	KD5	KD4	KD3	KD2	KD1	KD0	KRAM DATA (K20) TRACKING PHASE COMPENSATE FILTER A
								0	0	1	0	KD7	KD6	KD5	KD4	KD3	KD2	KD1	KD0	KRAM DATA (K21) TRACKING PHASE COMPENSATE FILTER B
								0	0	1	0	KD7	KD6	KD5	KD4	KD3	KD2	KD1	KD0	KRAM DATA (K22) TRACKING OUTPUT GAIN
								0	0	1	1	KD7	KD6	KD5	KD4	KD3	KD2	KD1	KD0	KRAM DATA (K23) TRACKING AUTO GAIN
								0	1	0	0	KD7	KD6	KD5	KD4	KD3	KD2	KD1	KD0	KRAM DATA (K24) FOCUS GAIN DOWN HIGH CUT FILTER A
								0	1	0	1	KD7	KD6	KD5	KD4	KD3	KD2	KD1	KD0	KRAM DATA (K25) FOCUS GAIN DOWN HIGH CUT FILTER B
								0	1	1	0	KD7	KD6	KD5	KD4	KD3	KD2	KD1	KD0	KRAM DATA (K26) FOCUS GAIN DOWN LOW BOOST FILTER A-H
								0	1	1	1	KD7	KD6	KD5	KD4	KD3	KD2	KD1	KD0	KRAM DATA (K27) FOCUS GAIN DOWN LOW BOOST FILTER A-L
								1	0	0	0	KD7	KD6	KD5	KD4	KD3	KD2	KD1	KD0	KRAM DATA (K28) FOCUS GAIN DOWN LOW BOOST FILTER B-H
								1	0	0	1	KD7	KD6	KD5	KD4	KD3	KD2	KD1	KD0	KRAM DATA (K29) FOCUS GAIN DOWN LOW BOOST FILTER B-L
								1	0	1	0	KD7	KD6	KD5	KD4	KD3	KD2	KD1	KD0	KRAM DATA (K2A) FOCUS GAIN DOWN PHASE COMPENSATE FILTER A
								1	0	1	1	KD7	KD6	KD5	KD4	KD3	KD2	KD1	KD0	KRAM DATA (K2B) FOCUS GAIN DOWN DEFECT HOLD GAIN
								1	1	0	0	KD7	KD6	KD5	KD4	KD3	KD2	KD1	KD0	KRAM DATA (K2C) FOCUS GAIN DOWN PHASE COMPENSATE FILTER B
								1	1	0	1	KD7	KD6	KD5	KD4	KD3	KD2	KD1	KD0	KRAM DATA (K2D) FOCUS GAIN DOWN OUTPUT GAIN
								1	1	1	0	KD7	KD6	KD5	KD4	KD3	KD2	KD1	KD0	KRAM DATA (K2E) NOT USED
								1	1	1	1	KD7	KD6	KD5	KD4	KD3	KD2	KD1	KD0	KRAM DATA (K2F) NOT USED

Command Table (\$343X)

Register	Command	Address 1		Address 2		Address 3		Address 4			Data 1				Data 2					
		D23 to D20		D19 to D16		D15 to D12		D11	D10	D9	D8	D7	D6	D5	D4	D3	D2	D1	D0	
3	SELECT	0 0 1 1		0 1 0 0	0 0 1 1	0 0 1 1	0	0	0	0	0	KD7	KD6	KD5	KD4	KD3	KD2	KD1	KD0	KRAM DATA (K30) SLED INPUT GAIN (when SF SK = 1 TG up2)
							0	0	0	1	0	KD7	KD6	KD5	KD4	KD3	KD2	KD1	KD0	KRAM DATA (K31) ANTI SHOCK LOW PASS FILTER B
							0	0	1	0	0	KD7	KD6	KD5	KD4	KD3	KD2	KD1	KD0	KRAM DATA (K32) NOT USED
							0	0	1	1	0	KD7	KD6	KD5	KD4	KD3	KD2	KD1	KD0	KRAM DATA (K33) ANTI SHOCK HIGH PASS FILTER B-H
							0	1	0	0	0	KD7	KD6	KD5	KD4	KD3	KD2	KD1	KD0	KRAM DATA (K34) ANTI SHOCK HIGH PASS FILTER B-L
							0	1	0	1	0	KD7	KD6	KD5	KD4	KD3	KD2	KD1	KD0	KRAM DATA (K35) ANTI SHOCK FILTER COMPARETE GAIN
							0	1	1	0	0	KD7	KD6	KD5	KD4	KD3	KD2	KD1	KD0	KRAM DATA (K36) TRACKING GAIN UP2 HIGH CUT FILTER A
							0	1	1	1	1	KD7	KD6	KD5	KD4	KD3	KD2	KD1	KD0	KRAM DATA (K37) TRACKING GAIN UP2 HIGH CUT FILTER B
							1	0	0	0	0	KD7	KD6	KD5	KD4	KD3	KD2	KD1	KD0	KRAM DATA (K38) TRACKING GAIN UP2 LOW BOOST FILTER A-H
							1	0	0	1	0	KD7	KD6	KD5	KD4	KD3	KD2	KD1	KD0	KRAM DATA (K39) TRACKING GAIN UP2 LOW BOOST FILTER A-L
							1	0	1	0	0	KD7	KD6	KD5	KD4	KD3	KD2	KD1	KD0	KRAM DATA (K3A) TRACKING GAIN UP2 LOW BOOST FILTER B-H
							1	0	1	1	1	KD7	KD6	KD5	KD4	KD3	KD2	KD1	KD0	KRAM DATA (K3B) TRACKING GAIN UP2 LOW BOOST FILTER B-L
							1	1	0	0	0	KD7	KD6	KD5	KD4	KD3	KD2	KD1	KD0	KRAM DATA (K3C) TRACKING GAIN UP PHASE COMPENSATE FILTER A
							1	1	0	1	0	KD7	KD6	KD5	KD4	KD3	KD2	KD1	KD0	KRAM DATA (K3D) TRACKING GAIN UP PHASE COMPENSATE FILTER B
							1	1	1	1	0	KD7	KD6	KD5	KD4	KD3	KD2	KD1	KD0	KRAM DATA (K3E) TRACKING GAIN UP OUTPUT GAIN
							1	1	1	1	1	KD7	KD6	KD5	KD4	KD3	KD2	KD1	KD0	KRAM DATA (K3F) NOT USED

Instruction Table

Register	Command	Address				Data 1				Data 2				Data 3				Data 4				Data 5				Data 6				
		D3	D2	D1	D0	D3	D2	D1	D0	D3	D2	D1	D0	D3	D2	D1	D0	D3	D2	D1	D0	D3	D2	D1	D0	D3	D2	D1	D0	
4	Auto sequence	0	1	0	0	AS3	AS2	AS1	AS0	—	—	—	—	—	—	—	—	—	—	—	—	—	—	—	—	—	—	—	—	
5	Blind (A, E), Overflow (C) Brake (B)	0	1	0	1	0.18ms	0.09ms	0.05ms	0.02ms	—	—	—	—	—	—	—	—	—	—	—	—	—	—	—	—	—	—	—		
						0.36ms	0.18ms	0.09ms	0.05ms																					
6	KICK (D)	0	1	1	0	11.6ms	5.8ms	2.9ms	1.45ms	—	—	—	—	—	—	—	—	—	—	—	—	—	—	—	—	—	—	—	—	
7	Auto sequence (N) track jump count setting	0	1	1	1	32768	16384	8192	4096	2048	1024	512	256	16	32	64	128	256	128	64	32	16	8	4	2	1	—	—	—	—
8	MODE specification	1	0	0	0	CDROM	DOUT Mute	DOUT ON/OFF	WSEL	VCO SEL1	0	SOCT	VCO SEL2	KSL3	KSL2	KSL1	KSL0	VCO THRU	0	0	0	0	0	0	0	0	0	0	0	0
9	Function specification	1	0	0	1	0	DSPB ON/OFF	0	0	0	0	0	SYCOF	0	OPSL1	MCSL	0	ZDPL	ZMUT	—	—	—	—	—	—	—	—	—	—	—
						0	DSPB ON/OFF	0	0	0	0	0	0	0	0	0	0	0	0	0	0	0	0	0	0	0	0	0	0	0
A	Audio CTRL	1	0	1	0	0	0	Mute	ATT	0	0	OPSL2	EMPH	SMUT	0	AD8	AD7	AD6	AD5	AD4	AD3	AD2	AD1	AD0	—	—	—	—	—	
						0	0	0	0	0	0	0	0	0	0	0	0	0	0	0	0	0	0	0	0	0	0	0	0	0
B	Serial bus CTRL	1	0	1	1	SL1	SL0	CPUSR	0	TRMI	TRMO	MTSL1	MTSL0	0	0	0	0	—	—	—	—	—	—	—	—	—	—	—	—	
C	Spindle servo coefficient setting	1	1	0	0	Gain MDP1	Gain MDP0	Gain MDS1	MDS0	—	—	—	—	—	—	—	—	—	—	—	—	—	—	—	—	—	—	—	—	
D	CLV CTRL	1	1	0	1	0	TB	TP	Gain CLVS	VP7	VP6	VP5	VP4	VP3	VP2	VP1	VP0	—	—	—	—	—	—	—	—	—	—	—	—	
E	CLV mode	1	1	1	0	CM3	CM2	CM1	CM0	EPWM	SPDC	ICAP	SFSL	VC2C	HIFC	LPWR	VPON	Gain CAV1	Gain CAV0	0	0	—	—	—	—	—	—	—	—	

§1-3. CPU Command Presets

Command Preset Table (\$0X to 34X)

Register	Command	Address																			
		Data 1			Data 2				Data 3				Data 4				Data 5				
		D19	D18	D17	D16	D15	D14	D13	D12	D11	D10	D9	D8	D7	D6	D5	D4	D3	D2	D1	D0
0	FOCUS CONTROL	0	0	0	0	—	—	—	—	—	—	—	—	—	—	—	—	—	—	—	—
1	TRACKING CONTROL	0	0	0	1	—	—	—	—	—	—	—	—	—	—	—	—	—	—	—	—
2	TRACKING MODE	0	0	0	0	—	—	—	—	—	—	—	—	—	—	—	—	—	—	—	—
Register	Command	Data 1			Data 2				Data 3				Data 4				Data 5				
		D19	D18	D17	D16	D15	D14	D13	D12	D11	D10	D9	D8	D7	D6	D5	D4	D3	D2	D1	D0
3	SELECT	Address 1			Address 2				Address 3				Data 1				Data 2				
		D19	D18	D17	D16	D15	D14	D13	D12	D11	D10	D9	D8	D7	D6	D5	D4	D3	D2	D1	D0
		0	1	0	0	0	—	—	—	—	—	—	—	—	—	—	—	—	—	—	—
		See "Coefficient ROM Preset Values Table".																			
		KRAM DATA (\$3400XX to \$344fXX)																			

—: Don't care

Command Preset Table (\$34FX to 3FX)

Register	Command	Address 1																Address 2				Data 1		Data 2				Data 3				Data 4					
		D23 to D20								D19	D18	D17	D16	D15	D14	D13	D12	D11	D10	D9	D8	D7	D6	D5	D4	D3	D2	D1	D0								
		0 0 1 1								0	1	0	0	1	1	1	1	1	0	0	0	0	0	0	0	0	0	0	0	0	0						
3	SELECT	Address 1																Address 2				Data 1		Data 2				Data 3				Data 4				FOCUS BIAS LIMIT	
		0 0 1 1								0	1	0 <td>0 <td>1 <td>1 <td>1 <td>1 <td>0</td> <td>0</td> <td>0</td> <td>0</td> <td>0</td> <td>0</td> <td>0</td> <td>0</td> <td>0</td> <td>0</td> <td>0</td> <td>0</td> <td>0</td> <td>0</td> <td>0</td> <td>0</td> <td>0</td> <td>0</td> <td>FOCUS BIAS DATA</td> </td></td></td></td></td>	0 <td>1 <td>1 <td>1 <td>1 <td>0</td> <td>0</td> <td>0</td> <td>0</td> <td>0</td> <td>0</td> <td>0</td> <td>0</td> <td>0</td> <td>0</td> <td>0</td> <td>0</td> <td>0</td> <td>0</td> <td>0</td> <td>0</td> <td>0</td> <td>0</td> <td>FOCUS BIAS DATA</td> </td></td></td></td>	1 <td>1 <td>1 <td>1 <td>0</td> <td>0</td> <td>0</td> <td>0</td> <td>0</td> <td>0</td> <td>0</td> <td>0</td> <td>0</td> <td>0</td> <td>0</td> <td>0</td> <td>0</td> <td>0</td> <td>0</td> <td>0</td> <td>0</td> <td>0</td> <td>FOCUS BIAS DATA</td> </td></td></td>	1 <td>1 <td>1 <td>0</td> <td>0</td> <td>0</td> <td>0</td> <td>0</td> <td>0</td> <td>0</td> <td>0</td> <td>0</td> <td>0</td> <td>0</td> <td>0</td> <td>0</td> <td>0</td> <td>0</td> <td>0</td> <td>0</td> <td>0</td> <td>FOCUS BIAS DATA</td> </td></td>	1 <td>1 <td>0</td> <td>0</td> <td>0</td> <td>0</td> <td>0</td> <td>0</td> <td>0</td> <td>0</td> <td>0</td> <td>0</td> <td>0</td> <td>0</td> <td>0</td> <td>0</td> <td>0</td> <td>0</td> <td>0</td> <td>0</td> <td>FOCUS BIAS DATA</td> </td>	1 <td>0</td> <td>0</td> <td>0</td> <td>0</td> <td>0</td> <td>0</td> <td>0</td> <td>0</td> <td>0</td> <td>0</td> <td>0</td> <td>0</td> <td>0</td> <td>0</td> <td>0</td> <td>0</td> <td>0</td> <td>0</td> <td>FOCUS BIAS DATA</td>	0	0	0	0	0	0	0	0	0	0	0	0	0	0	0	0	0	0	FOCUS BIAS DATA	
		0 0 1 1								0	1	0 <td>0 <td>1 <td>1 <td>1 <td>1 <td>0</td> <td>0</td> <td>0</td> <td>0</td> <td>0</td> <td>0</td> <td>0</td> <td>0</td> <td>0</td> <td>0</td> <td>0</td> <td>0</td> <td>0</td> <td>0</td> <td>0</td> <td>0</td> <td>0</td> <td>TRVSC DATA</td> </td></td></td></td></td>	0 <td>1 <td>1 <td>1 <td>1 <td>0</td> <td>0</td> <td>0</td> <td>0</td> <td>0</td> <td>0</td> <td>0</td> <td>0</td> <td>0</td> <td>0</td> <td>0</td> <td>0</td> <td>0</td> <td>0</td> <td>0</td> <td>0</td> <td>0</td> <td>TRVSC DATA</td> </td></td></td></td>	1 <td>1 <td>1 <td>1 <td>0</td> <td>0</td> <td>0</td> <td>0</td> <td>0</td> <td>0</td> <td>0</td> <td>0</td> <td>0</td> <td>0</td> <td>0</td> <td>0</td> <td>0</td> <td>0</td> <td>0</td> <td>0</td> <td>0</td> <td>TRVSC DATA</td> </td></td></td>	1 <td>1 <td>1 <td>0</td> <td>0</td> <td>0</td> <td>0</td> <td>0</td> <td>0</td> <td>0</td> <td>0</td> <td>0</td> <td>0</td> <td>0</td> <td>0</td> <td>0</td> <td>0</td> <td>0</td> <td>0</td> <td>0</td> <td>TRVSC DATA</td> </td></td>	1 <td>1 <td>0</td> <td>0</td> <td>0</td> <td>0</td> <td>0</td> <td>0</td> <td>0</td> <td>0</td> <td>0</td> <td>0</td> <td>0</td> <td>0</td> <td>0</td> <td>0</td> <td>0</td> <td>0</td> <td>0</td> <td>TRVSC DATA</td> </td>	1 <td>0</td> <td>0</td> <td>0</td> <td>0</td> <td>0</td> <td>0</td> <td>0</td> <td>0</td> <td>0</td> <td>0</td> <td>0</td> <td>0</td> <td>0</td> <td>0</td> <td>0</td> <td>0</td> <td>0</td> <td>TRVSC DATA</td>	0	0	0	0	0	0	0	0	0	0	0	0	0	0	0	0	0	TRVSC DATA		
		0 0 1 1								0	1	0 <td>0 <td>1 <td>1 <td>1 <td>1 <td>0</td> <td>0</td> <td>0</td> <td>0</td> <td>0</td> <td>0</td> <td>0</td> <td>0</td> <td>0</td> <td>0</td> <td>0</td> <td>0</td> <td>0</td> <td>0</td> <td>0</td> <td>0</td> <td>0</td> <td>FOCUS SEARCH SPEED/ VOLTAGE AUTO GAIN</td> </td></td></td></td></td>	0 <td>1 <td>1 <td>1 <td>1 <td>0</td> <td>0</td> <td>0</td> <td>0</td> <td>0</td> <td>0</td> <td>0</td> <td>0</td> <td>0</td> <td>0</td> <td>0</td> <td>0</td> <td>0</td> <td>0</td> <td>0</td> <td>0</td> <td>0</td> <td>FOCUS SEARCH SPEED/ VOLTAGE AUTO GAIN</td> </td></td></td></td>	1 <td>1 <td>1 <td>1 <td>0</td> <td>0</td> <td>0</td> <td>0</td> <td>0</td> <td>0</td> <td>0</td> <td>0</td> <td>0</td> <td>0</td> <td>0</td> <td>0</td> <td>0</td> <td>0</td> <td>0</td> <td>0</td> <td>0</td> <td>FOCUS SEARCH SPEED/ VOLTAGE AUTO GAIN</td> </td></td></td>	1 <td>1 <td>1 <td>0</td> <td>0</td> <td>0</td> <td>0</td> <td>0</td> <td>0</td> <td>0</td> <td>0</td> <td>0</td> <td>0</td> <td>0</td> <td>0</td> <td>0</td> <td>0</td> <td>0</td> <td>0</td> <td>0</td> <td>FOCUS SEARCH SPEED/ VOLTAGE AUTO GAIN</td> </td></td>	1 <td>1 <td>0</td> <td>0</td> <td>0</td> <td>0</td> <td>0</td> <td>0</td> <td>0</td> <td>0</td> <td>0</td> <td>0</td> <td>0</td> <td>0</td> <td>0</td> <td>0</td> <td>0</td> <td>0</td> <td>0</td> <td>FOCUS SEARCH SPEED/ VOLTAGE AUTO GAIN</td> </td>	1 <td>0</td> <td>0</td> <td>0</td> <td>0</td> <td>0</td> <td>0</td> <td>0</td> <td>0</td> <td>0</td> <td>0</td> <td>0</td> <td>0</td> <td>0</td> <td>0</td> <td>0</td> <td>0</td> <td>0</td> <td>FOCUS SEARCH SPEED/ VOLTAGE AUTO GAIN</td>	0	0	0	0	0	0	0	0	0	0	0	0	0	0	0	0	0	FOCUS SEARCH SPEED/ VOLTAGE AUTO GAIN		
		0 0 1 1								0	1	1 <td>0 <td>0 <td>0 <td>0 <td>0 <td>0 <td>0 <td>0 <td>0</td> <td>0</td> <td>0</td> <td>0</td> <td>0</td> <td>0</td> <td>0</td> <td>0</td> <td>0</td> <td>0</td> <td>0</td> <td>0</td> <td>0</td> <td>DTZC/TRACK JUMP VOLTAGE AUTO GAIN</td> </td></td></td></td></td></td></td></td>	0 <td>0 <td>0 <td>0 <td>0 <td>0 <td>0 <td>0 <td>0</td> <td>0</td> <td>0</td> <td>0</td> <td>0</td> <td>0</td> <td>0</td> <td>0</td> <td>0</td> <td>0</td> <td>0</td> <td>0</td> <td>0</td> <td>DTZC/TRACK JUMP VOLTAGE AUTO GAIN</td> </td></td></td></td></td></td></td>	0 <td>0 <td>0 <td>0 <td>0 <td>0 <td>0 <td>0</td> <td>0</td> <td>0</td> <td>0</td> <td>0</td> <td>0</td> <td>0</td> <td>0</td> <td>0</td> <td>0</td> <td>0</td> <td>0</td> <td>0</td> <td>DTZC/TRACK JUMP VOLTAGE AUTO GAIN</td> </td></td></td></td></td></td>	0 <td>0 <td>0 <td>0 <td>0 <td>0 <td>0</td> <td>0</td> <td>0</td> <td>0</td> <td>0</td> <td>0</td> <td>0</td> <td>0</td> <td>0</td> <td>0</td> <td>0</td> <td>0</td> <td>0</td> <td>DTZC/TRACK JUMP VOLTAGE AUTO GAIN</td> </td></td></td></td></td>	0 <td>0 <td>0 <td>0 <td>0 <td>0</td> <td>0</td> <td>0</td> <td>0</td> <td>0</td> <td>0</td> <td>0</td> <td>0</td> <td>0</td> <td>0</td> <td>0</td> <td>0</td> <td>0</td> <td>DTZC/TRACK JUMP VOLTAGE AUTO GAIN</td> </td></td></td></td>	0 <td>0 <td>0 <td>0 <td>0</td> <td>0</td> <td>0</td> <td>0</td> <td>0</td> <td>0</td> <td>0</td> <td>0</td> <td>0</td> <td>0</td> <td>0</td> <td>0</td> <td>0</td> <td>DTZC/TRACK JUMP VOLTAGE AUTO GAIN</td> </td></td></td>	0 <td>0 <td>0 <td>0</td> <td>0</td> <td>0</td> <td>0</td> <td>0</td> <td>0</td> <td>0</td> <td>0</td> <td>0</td> <td>0</td> <td>0</td> <td>0</td> <td>0</td> <td>DTZC/TRACK JUMP VOLTAGE AUTO GAIN</td> </td></td>	0 <td>0 <td>0</td> <td>0</td> <td>0</td> <td>0</td> <td>0</td> <td>0</td> <td>0</td> <td>0</td> <td>0</td> <td>0</td> <td>0</td> <td>0</td> <td>0</td> <td>DTZC/TRACK JUMP VOLTAGE AUTO GAIN</td> </td>	0 <td>0</td> <td>0</td> <td>0</td> <td>0</td> <td>0</td> <td>0</td> <td>0</td> <td>0</td> <td>0</td> <td>0</td> <td>0</td> <td>0</td> <td>0</td> <td>DTZC/TRACK JUMP VOLTAGE AUTO GAIN</td>	0	0	0	0	0	0	0	0	0	0	0	0	0	DTZC/TRACK JUMP VOLTAGE AUTO GAIN			
		0 0 1 1								0	1	1 <td>1 <td>0 <td>0 <td>0 <td>0 <td>0 <td>0 <td>0 <td>0</td> <td>0</td> <td>0</td> <td>0</td> <td>0</td> <td>0</td> <td>0</td> <td>0</td> <td>0</td> <td>0</td> <td>0</td> <td>0</td> <td>0</td> <td>0</td> <td>FZSL/SLED MOVE/ Voltage/AUTO GAIN</td> </td></td></td></td></td></td></td></td>	1 <td>0 <td>0 <td>0 <td>0 <td>0 <td>0 <td>0 <td>0</td> <td>0</td> <td>0</td> <td>0</td> <td>0</td> <td>0</td> <td>0</td> <td>0</td> <td>0</td> <td>0</td> <td>0</td> <td>0</td> <td>0</td> <td>0</td> <td>FZSL/SLED MOVE/ Voltage/AUTO GAIN</td> </td></td></td></td></td></td></td>	0 <td>0 <td>0 <td>0 <td>0 <td>0 <td>0 <td>0</td> <td>0</td> <td>0</td> <td>0</td> <td>0</td> <td>0</td> <td>0</td> <td>0</td> <td>0</td> <td>0</td> <td>0</td> <td>0</td> <td>0</td> <td>0</td> <td>FZSL/SLED MOVE/ Voltage/AUTO GAIN</td> </td></td></td></td></td></td>	0 <td>0 <td>0 <td>0 <td>0 <td>0 <td>0</td> <td>0</td> <td>0</td> <td>0</td> <td>0</td> <td>0</td> <td>0</td> <td>0</td> <td>0</td> <td>0</td> <td>0</td> <td>0</td> <td>0</td> <td>0</td> <td>FZSL/SLED MOVE/ Voltage/AUTO GAIN</td> </td></td></td></td></td>	0 <td>0 <td>0 <td>0 <td>0 <td>0</td> <td>0</td> <td>0</td> <td>0</td> <td>0</td> <td>0</td> <td>0</td> <td>0</td> <td>0</td> <td>0</td> <td>0</td> <td>0</td> <td>0</td> <td>0</td> <td>FZSL/SLED MOVE/ Voltage/AUTO GAIN</td> </td></td></td></td>	0 <td>0 <td>0 <td>0 <td>0</td> <td>0</td> <td>0</td> <td>0</td> <td>0</td> <td>0</td> <td>0</td> <td>0</td> <td>0</td> <td>0</td> <td>0</td> <td>0</td> <td>0</td> <td>0</td> <td>FZSL/SLED MOVE/ Voltage/AUTO GAIN</td> </td></td></td>	0 <td>0 <td>0 <td>0</td> <td>0</td> <td>0</td> <td>0</td> <td>0</td> <td>0</td> <td>0</td> <td>0</td> <td>0</td> <td>0</td> <td>0</td> <td>0</td> <td>0</td> <td>0</td> <td>FZSL/SLED MOVE/ Voltage/AUTO GAIN</td> </td></td>	0 <td>0 <td>0</td> <td>0</td> <td>0</td> <td>0</td> <td>0</td> <td>0</td> <td>0</td> <td>0</td> <td>0</td> <td>0</td> <td>0</td> <td>0</td> <td>0</td> <td>0</td> <td>FZSL/SLED MOVE/ Voltage/AUTO GAIN</td> </td>	0 <td>0</td> <td>0</td> <td>0</td> <td>0</td> <td>0</td> <td>0</td> <td>0</td> <td>0</td> <td>0</td> <td>0</td> <td>0</td> <td>0</td> <td>0</td> <td>0</td> <td>FZSL/SLED MOVE/ Voltage/AUTO GAIN</td>	0	0	0	0	0	0	0	0	0	0	0	0	0	0	FZSL/SLED MOVE/ Voltage/AUTO GAIN		
		0 0 1 1								1	0	0 <td>0 <td>0 <td>0 <td>0 <td>0 <td>0 <td>0 <td>0 <td>0</td> <td>0</td> <td>0</td> <td>0</td> <td>0</td> <td>0</td> <td>0</td> <td>0</td> <td>0</td> <td>0</td> <td>0</td> <td>0</td> <td>0</td> <td>0</td> <td>LEVEL/AUTO GAIN/ DFSW/ (Initialize)</td> </td></td></td></td></td></td></td></td>	0 <td>0 <td>0 <td>0 <td>0 <td>0 <td>0 <td>0 <td>0</td> <td>0</td> <td>0</td> <td>0</td> <td>0</td> <td>0</td> <td>0</td> <td>0</td> <td>0</td> <td>0</td> <td>0</td> <td>0</td> <td>0</td> <td>0</td> <td>LEVEL/AUTO GAIN/ DFSW/ (Initialize)</td> </td></td></td></td></td></td></td>	0 <td>0 <td>0 <td>0 <td>0 <td>0 <td>0 <td>0</td> <td>0</td> <td>0</td> <td>0</td> <td>0</td> <td>0</td> <td>0</td> <td>0</td> <td>0</td> <td>0</td> <td>0</td> <td>0</td> <td>0</td> <td>0</td> <td>LEVEL/AUTO GAIN/ DFSW/ (Initialize)</td> </td></td></td></td></td></td>	0 <td>0 <td>0 <td>0 <td>0 <td>0 <td>0</td> <td>0</td> <td>0</td> <td>0</td> <td>0</td> <td>0</td> <td>0</td> <td>0</td> <td>0</td> <td>0</td> <td>0</td> <td>0</td> <td>0</td> <td>0</td> <td>LEVEL/AUTO GAIN/ DFSW/ (Initialize)</td> </td></td></td></td></td>	0 <td>0 <td>0 <td>0 <td>0 <td>0</td> <td>0</td> <td>0</td> <td>0</td> <td>0</td> <td>0</td> <td>0</td> <td>0</td> <td>0</td> <td>0</td> <td>0</td> <td>0</td> <td>0</td> <td>0</td> <td>LEVEL/AUTO GAIN/ DFSW/ (Initialize)</td> </td></td></td></td>	0 <td>0 <td>0 <td>0 <td>0</td> <td>0</td> <td>0</td> <td>0</td> <td>0</td> <td>0</td> <td>0</td> <td>0</td> <td>0</td> <td>0</td> <td>0</td> <td>0</td> <td>0</td> <td>0</td> <td>LEVEL/AUTO GAIN/ DFSW/ (Initialize)</td> </td></td></td>	0 <td>0 <td>0 <td>0</td> <td>0</td> <td>0</td> <td>0</td> <td>0</td> <td>0</td> <td>0</td> <td>0</td> <td>0</td> <td>0</td> <td>0</td> <td>0</td> <td>0</td> <td>0</td> <td>LEVEL/AUTO GAIN/ DFSW/ (Initialize)</td> </td></td>	0 <td>0 <td>0</td> <td>0</td> <td>0</td> <td>0</td> <td>0</td> <td>0</td> <td>0</td> <td>0</td> <td>0</td> <td>0</td> <td>0</td> <td>0</td> <td>0</td> <td>0</td> <td>LEVEL/AUTO GAIN/ DFSW/ (Initialize)</td> </td>	0 <td>0</td> <td>0</td> <td>0</td> <td>0</td> <td>0</td> <td>0</td> <td>0</td> <td>0</td> <td>0</td> <td>0</td> <td>0</td> <td>0</td> <td>0</td> <td>0</td> <td>LEVEL/AUTO GAIN/ DFSW/ (Initialize)</td>	0	0	0	0	0	0	0	0	0	0	0	0	0	0	LEVEL/AUTO GAIN/ DFSW/ (Initialize)		
		0 0 1 1								1	0	0 <td>1 <td>0 <td>0 <td>0 <td>0 <td>0 <td>0 <td>0 <td>0 <td>0</td> <td>0</td> <td>0</td> <td>0</td> <td>0</td> <td>0</td> <td>0</td> <td>0</td> <td>0</td> <td>0</td> <td>0</td> <td>0</td> <td>0</td> <td>SERIAL DATA READ MODE/SELECT</td> </td></td></td></td></td></td></td></td></td>	1 <td>0 <td>0 <td>0 <td>0 <td>0 <td>0 <td>0 <td>0 <td>0</td> <td>0</td> <td>0</td> <td>0</td> <td>0</td> <td>0</td> <td>0</td> <td>0</td> <td>0</td> <td>0</td> <td>0</td> <td>0</td> <td>0</td> <td>SERIAL DATA READ MODE/SELECT</td> </td></td></td></td></td></td></td></td>	0 <td>0 <td>0 <td>0 <td>0 <td>0 <td>0 <td>0 <td>0</td> <td>0</td> <td>0</td> <td>0</td> <td>0</td> <td>0</td> <td>0</td> <td>0</td> <td>0</td> <td>0</td> <td>0</td> <td>0</td> <td>0</td> <td>SERIAL DATA READ MODE/SELECT</td> </td></td></td></td></td></td></td>	0 <td>0 <td>0 <td>0 <td>0 <td>0 <td>0 <td>0</td> <td>0</td> <td>0</td> <td>0</td> <td>0</td> <td>0</td> <td>0</td> <td>0</td> <td>0</td> <td>0</td> <td>0</td> <td>0</td> <td>0</td> <td>SERIAL DATA READ MODE/SELECT</td> </td></td></td></td></td></td>	0 <td>0 <td>0 <td>0 <td>0 <td>0 <td>0</td> <td>0</td> <td>0</td> <td>0</td> <td>0</td> <td>0</td> <td>0</td> <td>0</td> <td>0</td> <td>0</td> <td>0</td> <td>0</td> <td>0</td> <td>SERIAL DATA READ MODE/SELECT</td> </td></td></td></td></td>	0 <td>0 <td>0 <td>0 <td>0 <td>0</td> <td>0</td> <td>0</td> <td>0</td> <td>0</td> <td>0</td> <td>0</td> <td>0</td> <td>0</td> <td>0</td> <td>0</td> <td>0</td> <td>0</td> <td>SERIAL DATA READ MODE/SELECT</td> </td></td></td></td>	0 <td>0 <td>0 <td>0 <td>0</td> <td>0</td> <td>0</td> <td>0</td> <td>0</td> <td>0</td> <td>0</td> <td>0</td> <td>0</td> <td>0</td> <td>0</td> <td>0</td> <td>0</td> <td>SERIAL DATA READ MODE/SELECT</td> </td></td></td>	0 <td>0 <td>0 <td>0</td> <td>0</td> <td>0</td> <td>0</td> <td>0</td> <td>0</td> <td>0</td> <td>0</td> <td>0</td> <td>0</td> <td>0</td> <td>0</td> <td>0</td> <td>SERIAL DATA READ MODE/SELECT</td> </td></td>	0 <td>0 <td>0</td> <td>0</td> <td>0</td> <td>0</td> <td>0</td> <td>0</td> <td>0</td> <td>0</td> <td>0</td> <td>0</td> <td>0</td> <td>0</td> <td>0</td> <td>SERIAL DATA READ MODE/SELECT</td> </td>	0 <td>0</td> <td>0</td> <td>0</td> <td>0</td> <td>0</td> <td>0</td> <td>0</td> <td>0</td> <td>0</td> <td>0</td> <td>0</td> <td>0</td> <td>0</td> <td>SERIAL DATA READ MODE/SELECT</td>	0	0	0	0	0	0	0	0	0	0	0	0	0	SERIAL DATA READ MODE/SELECT		
		0 0 1 1								1	0	1 <td>0 <td>0 <td>0 <td>0 <td>0 <td>0 <td>0 <td>0 <td>0 <td>0</td> <td>0</td> <td>0</td> <td>0</td> <td>0</td> <td>0</td> <td>0</td> <td>0</td> <td>0</td> <td>0</td> <td>0</td> <td>0</td> <td>0</td> <td>0</td> <td>FOCUS BIAS</td> </td></td></td></td></td></td></td></td></td>	0 <td>0 <td>0 <td>0 <td>0 <td>0 <td>0 <td>0 <td>0 <td>0</td> <td>0</td> <td>0</td> <td>0</td> <td>0</td> <td>0</td> <td>0</td> <td>0</td> <td>0</td> <td>0</td> <td>0</td> <td>0</td> <td>0</td> <td>0</td> <td>FOCUS BIAS</td> </td></td></td></td></td></td></td></td>	0 <td>0 <td>0 <td>0 <td>0 <td>0 <td>0 <td>0 <td>0</td> <td>0</td> <td>0</td> <td>0</td> <td>0</td> <td>0</td> <td>0</td> <td>0</td> <td>0</td> <td>0</td> <td>0</td> <td>0</td> <td>0</td> <td>0</td> <td>FOCUS BIAS</td> </td></td></td></td></td></td></td>	0 <td>0 <td>0 <td>0 <td>0 <td>0 <td>0 <td>0</td> <td>0</td> <td>0</td> <td>0</td> <td>0</td> <td>0</td> <td>0</td> <td>0</td> <td>0</td> <td>0</td> <td>0</td> <td>0</td> <td>0</td> <td>0</td> <td>FOCUS BIAS</td> </td></td></td></td></td></td>	0 <td>0 <td>0 <td>0 <td>0 <td>0 <td>0</td> <td>0</td> <td>0</td> <td>0</td> <td>0</td> <td>0</td> <td>0</td> <td>0</td> <td>0</td> <td>0</td> <td>0</td> <td>0</td> <td>0</td> <td>0</td> <td>FOCUS BIAS</td> </td></td></td></td></td>	0 <td>0 <td>0 <td>0 <td>0 <td>0</td> <td>0</td> <td>0</td> <td>0</td> <td>0</td> <td>0</td> <td>0</td> <td>0</td> <td>0</td> <td>0</td> <td>0</td> <td>0</td> <td>0</td> <td>0</td> <td>FOCUS BIAS</td> </td></td></td></td>	0 <td>0 <td>0 <td>0 <td>0</td> <td>0</td> <td>0</td> <td>0</td> <td>0</td> <td>0</td> <td>0</td> <td>0</td> <td>0</td> <td>0</td> <td>0</td> <td>0</td> <td>0</td> <td>0</td> <td>FOCUS BIAS</td> </td></td></td>	0 <td>0 <td>0 <td>0</td> <td>0</td> <td>0</td> <td>0</td> <td>0</td> <td>0</td> <td>0</td> <td>0</td> <td>0</td> <td>0</td> <td>0</td> <td>0</td> <td>0</td> <td>0</td> <td>FOCUS BIAS</td> </td></td>	0 <td>0 <td>0</td> <td>0</td> <td>0</td> <td>0</td> <td>0</td> <td>0</td> <td>0</td> <td>0</td> <td>0</td> <td>0</td> <td>0</td> <td>0</td> <td>0</td> <td>0</td> <td>FOCUS BIAS</td> </td>	0 <td>0</td> <td>0</td> <td>0</td> <td>0</td> <td>0</td> <td>0</td> <td>0</td> <td>0</td> <td>0</td> <td>0</td> <td>0</td> <td>0</td> <td>0</td> <td>0</td> <td>FOCUS BIAS</td>	0	0	0	0	0	0	0	0	0	0	0	0	0	0	FOCUS BIAS	
		0 0 1 1								1	0	1 <td>1 <td>1 <td>1 <td>1 <td>1 <td>1 <td>0 <td>0</td> <td>0</td> <td>0</td> <td>0</td> <td>0</td> <td>0</td> <td>0</td> <td>1</td> <td>0</td> <td>0</td> <td>0</td> <td>0</td> <td>0</td> <td>0</td> <td>0</td> <td>0</td> <td>0</td> <td>Operation for MIRR/ DFCT/FOK</td> </td></td></td></td></td></td></td>	1 <td>1 <td>1 <td>1 <td>1 <td>1 <td>0 <td>0</td> <td>0</td> <td>0</td> <td>0</td> <td>0</td> <td>0</td> <td>0</td> <td>1</td> <td>0</td> <td>0</td> <td>0</td> <td>0</td> <td>0</td> <td>0</td> <td>0</td> <td>0</td> <td>0</td> <td>Operation for MIRR/ DFCT/FOK</td> </td></td></td></td></td></td>	1 <td>1 <td>1 <td>1 <td>1 <td>0 <td>0</td> <td>0</td> <td>0</td> <td>0</td> <td>0</td> <td>0</td> <td>0</td> <td>1</td> <td>0</td> <td>0</td> <td>0</td> <td>0</td> <td>0</td> <td>0</td> <td>0</td> <td>0</td> <td>0</td> <td>Operation for MIRR/ DFCT/FOK</td> </td></td></td></td></td>	1 <td>1 <td>1 <td>1 <td>0 <td>0</td> <td>0</td> <td>0</td> <td>0</td> <td>0</td> <td>0</td> <td>0</td> <td>1</td> <td>0</td> <td>0</td> <td>0</td> <td>0</td> <td>0</td> <td>0</td> <td>0</td> <td>0</td> <td>0</td> <td>Operation for MIRR/ DFCT/FOK</td> </td></td></td></td>	1 <td>1 <td>1 <td>0 <td>0</td> <td>0</td> <td>0</td> <td>0</td> <td>0</td> <td>0</td> <td>0</td> <td>1</td> <td>0</td> <td>0</td> <td>0</td> <td>0</td> <td>0</td> <td>0</td> <td>0</td> <td>0</td> <td>0</td> <td>Operation for MIRR/ DFCT/FOK</td> </td></td></td>	1 <td>1 <td>0 <td>0</td> <td>0</td> <td>0</td> <td>0</td> <td>0</td> <td>0</td> <td>0</td> <td>1</td> <td>0</td> <td>0</td> <td>0</td> <td>0</td> <td>0</td> <td>0</td> <td>0</td> <td>0</td> <td>0</td> <td>Operation for MIRR/ DFCT/FOK</td> </td></td>	1 <td>0 <td>0</td> <td>0</td> <td>0</td> <td>0</td> <td>0</td> <td>0</td> <td>0</td> <td>1</td> <td>0</td> <td>0</td> <td>0</td> <td>0</td> <td>0</td> <td>0</td> <td>0</td> <td>0</td> <td>0</td> <td>Operation for MIRR/ DFCT/FOK</td> </td>	0 <td>0</td> <td>0</td> <td>0</td> <td>0</td> <td>0</td> <td>0</td> <td>0</td> <td>1</td> <td>0</td> <td>0</td> <td>0</td> <td>0</td> <td>0</td> <td>0</td> <td>0</td> <td>0</td> <td>0</td> <td>Operation for MIRR/ DFCT/FOK</td>	0	0	0	0	0	0	0	1	0	0	0	0	0	0	0	0	0	Operation for MIRR/ DFCT/FOK
		0 0 1 1								1	1	0 <td>0 <td>0 <td>0 <td>0 <td>0 <td>0 <td>0 <td>0 <td>0</td> <td>0</td> <td>0</td> <td>0</td> <td>0</td> <td>0</td> <td>0</td> <td>0</td> <td>0</td> <td>0</td> <td>0</td> <td>0</td> <td>0</td> <td>0</td> <td>0</td> <td>0</td> <td>TZC/COU BOTTOM/MIRR</td> </td></td></td></td></td></td></td></td>	0 <td>0 <td>0 <td>0 <td>0 <td>0 <td>0 <td>0 <td>0</td> <td>0</td> <td>0</td> <td>0</td> <td>0</td> <td>0</td> <td>0</td> <td>0</td> <td>0</td> <td>0</td> <td>0</td> <td>0</td> <td>0</td> <td>0</td> <td>0</td> <td>0</td> <td>TZC/COU BOTTOM/MIRR</td> </td></td></td></td></td></td></td>	0 <td>0 <td>0 <td>0 <td>0 <td>0 <td>0 <td>0</td> <td>0</td> <td>0</td> <td>0</td> <td>0</td> <td>0</td> <td>0</td> <td>0</td> <td>0</td> <td>0</td> <td>0</td> <td>0</td> <td>0</td> <td>0</td> <td>0</td> <td>0</td> <td>TZC/COU BOTTOM/MIRR</td> </td></td></td></td></td></td>	0 <td>0 <td>0 <td>0 <td>0 <td>0 <td>0</td> <td>0</td> <td>0</td> <td>0</td> <td>0</td> <td>0</td> <td>0</td> <td>0</td> <td>0</td> <td>0</td> <td>0</td> <td>0</td> <td>0</td> <td>0</td> <td>0</td> <td>0</td> <td>TZC/COU BOTTOM/MIRR</td> </td></td></td></td></td>	0 <td>0 <td>0 <td>0 <td>0 <td>0</td> <td>0</td> <td>0</td> <td>0</td> <td>0</td> <td>0</td> <td>0</td> <td>0</td> <td>0</td> <td>0</td> <td>0</td> <td>0</td> <td>0</td> <td>0</td> <td>0</td> <td>0</td> <td>TZC/COU BOTTOM/MIRR</td> </td></td></td></td>	0 <td>0 <td>0 <td>0 <td>0</td> <td>0</td> <td>0</td> <td>0</td> <td>0</td> <td>0</td> <td>0</td> <td>0</td> <td>0</td> <td>0</td> <td>0</td> <td>0</td> <td>0</td> <td>0</td> <td>0</td> <td>0</td> <td>TZC/COU BOTTOM/MIRR</td> </td></td></td>	0 <td>0 <td>0 <td>0</td> <td>0</td> <td>0</td> <td>0</td> <td>0</td> <td>0</td> <td>0</td> <td>0</td> <td>0</td> <td>0</td> <td>0</td> <td>0</td> <td>0</td> <td>0</td> <td>0</td> <td>0</td> <td>TZC/COU BOTTOM/MIRR</td> </td></td>	0 <td>0 <td>0</td> <td>0</td> <td>0</td> <td>0</td> <td>0</td> <td>0</td> <td>0</td> <td>0</td> <td>0</td> <td>0</td> <td>0</td> <td>0</td> <td>0</td> <td>0</td> <td>0</td> <td>0</td> <td>TZC/COU BOTTOM/MIRR</td> </td>	0 <td>0</td> <td>0</td> <td>0</td> <td>0</td> <td>0</td> <td>0</td> <td>0</td> <td>0</td> <td>0</td> <td>0</td> <td>0</td> <td>0</td> <td>0</td> <td>0</td> <td>0</td> <td>0</td> <td>TZC/COU BOTTOM/MIRR</td>	0	0	0	0	0	0	0	0	0	0	0	0	0	0	0	0	TZC/COU BOTTOM/MIRR
		0 0 1 1								1	1	0 <td>1 <td>0 <td>0 <td>0 <td>0 <td>0 <td>0 <td>0 <td>0</td> <td>0</td> <td>0</td> <td>0</td> <td>0</td> <td>0</td> <td>0</td> <td>0</td> <td>0</td> <td>0</td> <td>0</td> <td>0</td> <td>0</td> <td>0</td> <td>0</td> <td>0</td> <td>SLED FILTER</td> </td></td></td></td></td></td></td></td>	1 <td>0 <td>0 <td>0 <td>0 <td>0 <td>0 <td>0 <td>0</td> <td>0</td> <td>0</td> <td>0</td> <td>0</td> <td>0</td> <td>0</td> <td>0</td> <td>0</td> <td>0</td> <td>0</td> <td>0</td> <td>0</td> <td>0</td> <td>0</td> <td>0</td> <td>SLED FILTER</td> </td></td></td></td></td></td></td>	0 <td>0 <td>0 <td>0 <td>0 <td>0 <td>0 <td>0</td> <td>0</td> <td>0</td> <td>0</td> <td>0</td> <td>0</td> <td>0</td> <td>0</td> <td>0</td> <td>0</td> <td>0</td> <td>0</td> <td>0</td> <td>0</td> <td>0</td> <td>0</td> <td>SLED FILTER</td> </td></td></td></td></td></td>	0 <td>0 <td>0 <td>0 <td>0 <td>0 <td>0</td> <td>0</td> <td>0</td> <td>0</td> <td>0</td> <td>0</td> <td>0</td> <td>0</td> <td>0</td> <td>0</td> <td>0</td> <td>0</td> <td>0</td> <td>0</td> <td>0</td> <td>0</td> <td>SLED FILTER</td> </td></td></td></td></td>	0 <td>0 <td>0 <td>0 <td>0 <td>0</td> <td>0</td> <td>0</td> <td>0</td> <td>0</td> <td>0</td> <td>0</td> <td>0</td> <td>0</td> <td>0</td> <td>0</td> <td>0</td> <td>0</td> <td>0</td> <td>0</td> <td>0</td> <td>SLED FILTER</td> </td></td></td></td>	0 <td>0 <td>0 <td>0 <td>0</td> <td>0</td> <td>0</td> <td>0</td> <td>0</td> <td>0</td> <td>0</td> <td>0</td> <td>0</td> <td>0</td> <td>0</td> <td>0</td> <td>0</td> <td>0</td> <td>0</td> <td>0</td> <td>SLED FILTER</td> </td></td></td>	0 <td>0 <td>0 <td>0</td> <td>0</td> <td>0</td> <td>0</td> <td>0</td> <td>0</td> <td>0</td> <td>0</td> <td>0</td> <td>0</td> <td>0</td> <td>0</td> <td>0</td> <td>0</td> <td>0</td> <td>0</td> <td>SLED FILTER</td> </td></td>	0 <td>0 <td>0</td> <td>0</td> <td>0</td> <td>0</td> <td>0</td> <td>0</td> <td>0</td> <td>0</td> <td>0</td> <td>0</td> <td>0</td> <td>0</td> <td>0</td> <td>0</td> <td>0</td> <td>0</td> <td>SLED FILTER</td> </td>	0 <td>0</td> <td>0</td> <td>0</td> <td>0</td> <td>0</td> <td>0</td> <td>0</td> <td>0</td> <td>0</td> <td>0</td> <td>0</td> <td>0</td> <td>0</td> <td>0</td> <td>0</td> <td>0</td> <td>SLED FILTER</td>	0	0	0	0	0	0	0	0	0	0	0	0	0	0	0	0	SLED FILTER
0 0 1 1								1	1	1 <td>0 <td>0 <td>0 <td>0 <td>0 <td>0 <td>0 <td>0</td> <td>0</td> <td>0</td> <td>0</td> <td>0</td> <td>0</td> <td>0</td> <td>0</td> <td>0</td> <td>0</td> <td>0</td> <td>0</td> <td>0</td> <td>0</td> <td>0</td> <td>0</td> <td>0</td> <td>Filter</td> </td></td></td></td></td></td></td>	0 <td>0 <td>0 <td>0 <td>0 <td>0 <td>0 <td>0</td> <td>0</td> <td>0</td> <td>0</td> <td>0</td> <td>0</td> <td>0</td> <td>0</td> <td>0</td> <td>0</td> <td>0</td> <td>0</td> <td>0</td> <td>0</td> <td>0</td> <td>0</td> <td>0</td> <td>Filter</td> </td></td></td></td></td></td>	0 <td>0 <td>0 <td>0 <td>0 <td>0 <td>0</td> <td>0</td> <td>0</td> <td>0</td> <td>0</td> <td>0</td> <td>0</td> <td>0</td> <td>0</td> <td>0</td> <td>0</td> <td>0</td> <td>0</td> <td>0</td> <td>0</td> <td>0</td> <td>0</td> <td>Filter</td> </td></td></td></td></td>	0 <td>0 <td>0 <td>0 <td>0 <td>0</td> <td>0</td> <td>0</td> <td>0</td> <td>0</td> <td>0</td> <td>0</td> <td>0</td> <td>0</td> <td>0</td> <td>0</td> <td>0</td> <td>0</td> <td>0</td> <td>0</td> <td>0</td> <td>0</td> <td>Filter</td> </td></td></td></td>	0 <td>0 <td>0 <td>0 <td>0</td> <td>0</td> <td>0</td> <td>0</td> <td>0</td> <td>0</td> <td>0</td> <td>0</td> <td>0</td> <td>0</td> <td>0</td> <td>0</td> <td>0</td> <td>0</td> <td>0</td> <td>0</td> <td>0</td> <td>Filter</td> </td></td></td>	0 <td>0 <td>0 <td>0</td> <td>0</td> <td>0</td> <td>0</td> <td>0</td> <td>0</td> <td>0</td> <td>0</td> <td>0</td> <td>0</td> <td>0</td> <td>0</td> <td>0</td> <td>0</td> <td>0</td> <td>0</td> <td>0</td> <td>Filter</td> </td></td>	0 <td>0 <td>0</td> <td>0</td> <td>0</td> <td>0</td> <td>0</td> <td>0</td> <td>0</td> <td>0</td> <td>0</td> <td>0</td> <td>0</td> <td>0</td> <td>0</td> <td>0</td> <td>0</td> <td>0</td> <td>0</td> <td>Filter</td> </td>	0 <td>0</td> <td>0</td> <td>0</td> <td>0</td> <td>0</td> <td>0</td> <td>0</td> <td>0</td> <td>0</td> <td>0</td> <td>0</td> <td>0</td> <td>0</td> <td>0</td> <td>0</td> <td>0</td> <td>0</td> <td>Filter</td>	0	0	0	0	0	0	0	0	0	0	0	0	0	0	0	0	0	Filter		
0 0 1 1								1	1	1 <td>1 <td>0 <td>0 <td>0 <td>0 <td>0 <td>0 <td>0</td> <td>0</td> <td>0</td> <td>0</td> <td>0</td> <td>0</td> <td>0</td> <td>0</td> <td>0</td> <td>0</td> <td>0</td> <td>0</td> <td>0</td> <td>0</td> <td>0</td> <td>0</td> <td>0</td> <td>0</td> <td>Others</td> </td></td></td></td></td></td></td>	1 <td>0 <td>0 <td>0 <td>0 <td>0 <td>0 <td>0</td> <td>0</td> <td>0</td> <td>0</td> <td>0</td> <td>0</td> <td>0</td> <td>0</td> <td>0</td> <td>0</td> <td>0</td> <td>0</td> <td>0</td> <td>0</td> <td>0</td> <td>0</td> <td>0</td> <td>0</td> <td>Others</td> </td></td></td></td></td></td>	0 <td>0 <td>0 <td>0 <td>0 <td>0 <td>0</td> <td>0</td> <td>0</td> <td>0</td> <td>0</td> <td>0</td> <td>0</td> <td>0</td> <td>0</td> <td>0</td> <td>0</td> <td>0</td> <td>0</td> <td>0</td> <td>0</td> <td>0</td> <td>0</td> <td>0</td> <td>Others</td> </td></td></td></td></td>	0 <td>0 <td>0 <td>0 <td>0 <td>0</td> <td>0</td> <td>0</td> <td>0</td> <td>0</td> <td>0</td> <td>0</td> <td>0</td> <td>0</td> <td>0</td> <td>0</td> <td>0</td> <td>0</td> <td>0</td> <td>0</td> <td>0</td> <td>0</td> <td>0</td> <td>Others</td> </td></td></td></td>	0 <td>0 <td>0 <td>0 <td>0</td> <td>0</td> <td>0</td> <td>0</td> <td>0</td> <td>0</td> <td>0</td> <td>0</td> <td>0</td> <td>0</td> <td>0</td> <td>0</td> <td>0</td> <td>0</td> <td>0</td> <td>0</td> <td>0</td> <td>0</td> <td>Others</td> </td></td></td>	0 <td>0 <td>0 <td>0</td> <td>0</td> <td>0</td> <td>0</td> <td>0</td> <td>0</td> <td>0</td> <td>0</td> <td>0</td> <td>0</td> <td>0</td> <td>0</td> <td>0</td> <td>0</td> <td>0</td> <td>0</td> <td>0</td> <td>0</td> <td>Others</td> </td></td>	0 <td>0 <td>0</td> <td>0</td> <td>0</td> <td>0</td> <td>0</td> <td>0</td> <td>0</td> <td>0</td> <td>0</td> <td>0</td> <td>0</td> <td>0</td> <td>0</td> <td>0</td> <td>0</td> <td>0</td> <td>0</td> <td>0</td> <td>Others</td> </td>	0 <td>0</td> <td>0</td> <td>0</td> <td>0</td> <td>0</td> <td>0</td> <td>0</td> <td>0</td> <td>0</td> <td>0</td> <td>0</td> <td>0</td> <td>0</td> <td>0</td> <td>0</td> <td>0</td> <td>0</td> <td>0</td> <td>Others</td>	0	0	0	0	0	0	0	0	0	0	0	0	0	0	0	0	0	0	Others	

—: Don't care

<Coefficient ROM Preset Values Table (1)>

ADDRESS	DATA	CONTENTS
K00	E0	SLED INPUT GAIN
K01	81	SLED LOW BOOST FILTER A-H
K02	23	SLED LOW BOOST FILTER A-L
K03	7F	SLED LOW BOOST FILTER B-H
K04	6A	SLED LOW BOOST FILTER B-L
K05	10	SLED OUTPUT GAIN
K06	14	FOCUS INPUT GAIN
K07	30	SLED AUTO GAIN
K08	7F	FOCUS HIGH CUT FILTER A
K09	46	FOCUS HIGH CUT FILTER B
K0A	81	FOCUS LOW BOOST FILTER A-H
K0B	1C	FOCUS LOW BOOST FILTER A-L
K0C	7F	FOCUS LOW BOOST FILTER B-H
K0D	58	FOCUS LOW BOOST FILTER B-L
K0E	82	FOCUS PHASE COMPENSATE FILTER A
K0F	7F	FOCUS DEFECT HOLD GAIN
K10	4E	FOCUS PHASE COMPENSATE FILTER B
K11	32	FOCUS OUTPUT GAIN
K12	20	ANTI SHOCK INPUT GAIN
K13	30	FOCUS AUTO GAIN
K14	80	HPTZC / Auto Gain HIGH PASS FILTER A
K15	77	HPTZC / Auto Gain HIGH PASS FILTER B
K16	80	ANTI SHOCK HIGH PASS FILTER A
K17	77	HPTZC / Auto Gain LOW PASS FILTER B
K18	00	Fix*
K19	F1	TRACKING INPUT GAIN
K1A	7F	TRACKING HIGH CUT FILTER A
K1B	3B	TRACKING HIGH CUT FILTER B
K1C	81	TRACKING LOW BOOST FILTER A-H
K1D	44	TRACKING LOW BOOST FILTER A-L
K1E	7F	TRACKING LOW BOOST FILTER B-H
K1F	5E	TRACKING LOW BOOST FILTER B-L
K20	82	TRACKING PHASE COMPENSATE FILTER A
K21	44	TRACKING PHASE COMPENSATE FILTER B
K22	18	TRACKING OUTPUT GAIN
K23	30	TRACKING AUTO GAIN
K24	7F	FOCUS GAIN DOWN HIGH CUT FILTER A
K25	46	FOCUS GAIN DOWN HIGH CUT FILTER B
K26	81	FOCUS GAIN DOWN LOW BOOST FILTER A-H
K27	3A	FOCUS GAIN DOWN LOW BOOST FILTER A-L
K28	7F	FOCUS GAIN DOWN LOW BOOST FILTER B-H
K29	66	FOCUS GAIN DOWN LOW BOOST FILTER B-L
K2A	82	FOCUS GAIN DOWN PHASE COMPENSATE FILTER A
K2B	44	FOCUS GAIN DOWN DEFECT HOLD GAIN
K2C	4E	FOCUS GAIN DOWN PHASE COMPENSATE FILTER B
K2D	1B	FOCUS GAIN DOWN OUTPUT GAIN
K2E	00	NOT USED
K2F	00	NOT USED

* Fix indicates that normal preset values should be used.

<Coefficient ROM Preset Values Table (2)>

ADDRESS	DATA	CONTENTS
K30	80	SLED INPUT GAIN (Only when TRK Gain Up2 is accessed with SFSK = 1.)
K31	66	ANTI SHOCK LOW PASS FILTER B
K32	00	NOT USED
K33	7F	ANTI SHOCK HIGH PASS FILTER B-H
K34	6E	ANTI SHOCK HIGH PASS FILTER B-L
K35	20	ANTI SHOCK FILTER COMPARATE GAIN
K36	7F	TRACKING GAIN UP2 HIGH CUT FILTER A
K37	3B	TRACKING GAIN UP2 HIGH CUT FILTER B
K38	80	TRACKING GAIN UP2 LOW BOOST FILTER A-H
K39	44	TRACKING GAIN UP2 LOW BOOST FILTER A-L
K3A	7F	TRACKING GAIN UP2 LOW BOOST FILTER B-H
K3B	77	TRACKING GAIN UP2 LOW BOOST FILTER B-L
K3C	86	TRACKING GAIN UP PHASE COMPENSATE FILTER A
K3D	0D	TRACKING GAIN UP PHASE COMPENSATE FILTER B
K3E	57	TRACKING GAIN UP OUTPUT GAIN
K3F	00	NOT USED
K40	04	TRACKING HOLD FILTER INPUT GAIN
K41	7F	TRACKING HOLD FILTER A-H
K42	7F	TRACKING HOLD FILTER A-L
K43	79	TRACKING HOLD FILTER B-H
K44	17	TRACKING HOLD FILTER B-L
K45	6D	TRACKING HOLD FILTER OUTPUT GAIN
K46	00	TRACKING HOLD FILTER INPUT GAIN (Only when TRK Gain Up2 is a accessed with THSK = 1.)
K47	00	NOT USED
K48	02	FOCUS HOLD FILTER INPUT GAIN
K49	7F	FOCUS HOLD FILTER A-H
K4A	7F	FOCUS HOLD FILTER A-L
K4B	79	FOCUS HOLD FILTER B-H
K4C	17	FOCUS HOLD FILTER B-L
K4D	54	FOCUS HOLD FILTER OUTPUT GAIN
K4E	00	NOT USED
K4F	00	NOT USED

§1-4. Description of SENS Signals and Commands

SENS output

Microcomputer serial register (latching not required)	SENS output	Output data length
\$0X	FZC	—
\$1X	As (Anti Shock)	—
\$2X	TZC	—
\$30 to 37	SSTP	—
\$38	AGOK	—
\$38	XA VEBSY	—
\$3904	TE Avg Reg.	9bit
\$3908	FE Avg Reg.	9bit
\$390C	VC Avg Reg.	9bit
\$391C	TRVSC Reg.	9bit
\$391D	FB Reg.	9bit
\$391F	RFDC Avg. Reg.	8bit
\$3A	FBIAS count STOP	—
\$3B to 3F	SSTP	—
\$4X	XBUSY	—
\$5X	FOK	—
\$6X, 7X, 8X, 9X	0	—
\$AX	GFS	—
\$BX	0	—
\$CX	COUT frequency division	—
\$DX	0	—
\$EX	OV64	—
\$FX	0	—

The SENS output can be read from the SQSO pin when SOUT = 0, SL1 = 1 and SL0 = 0.

\$38 outputs AGOK during AGT and AGF command settings, and XAVEBSY during AVRG measurement. SSTP is output in all other cases.

Description of SENS Signals

SENS output	Contents
XBUSY	Low while the auto sequencer is in operation, high when operation terminates.
FOK	Outputs the same signal as the FOK pin. High for "focus OK".
GFS	High when the regenerated frame sync is obtained with the correct timing.
COUT frequency division	Counts the number of tracks with frequency division ratio set by \$B. High when \$C is latched, and toggles each time COUT is counted just for the frequency division ratio set by \$B.
OV64	Low when the EFM signal is lengthened by 64 channel clock pulses or more after passing through the sync detection filter.

The meaning of the data for each address is explained below.

\$4X commands

Command	AS3	AS2	AS1	AS0
CANCEL	0	0	0	0
FOCUS-ON	0	1	1	1
1 TRACK JUMP	1	0	0	RXF
10 TRACK JUMP	1	0	1	RXF
2 NTRACK JUMP	1	1	0	RXF
N TRACK MOVE	1	1	1	RXF

RXF = 0 FORWARD

RXF = 1 REVERSE

- When the Focus-on command (\$47) is canceled, \$02 is sent and the auto sequence is interrupted.
- When the Track jump/Move commands (\$48 to \$4F) are canceled, \$25 is sent and the auto sequence is interrupted.

\$5X commands

Auto sequence timer setting

Set timers: A, E, C, B

Command	D23	D22	D21	D20
Blind (A, E), Over flow (C)	0.18ms	0.09ms	0.05ms	0.02ms
Brake (B)	0.36ms	0.18ms	0.09ms	0.05ms

e.g.) D2 = D0 = 1, D3 = D1 = 0 (Initial Reset)

A = E = C = 0.11ms

B = 0.23ms

\$6X commands

Auto sequence timer setting

Set timer: D

Command	D23	D22	D21	D20
KICK (D)	11.6ms	5.8ms	2.9ms	1.45ms

e.g.) D3 = 0, D2 = D1 = D0 = 1 (Initial Reset)

D = 10.15ms

\$7X commands

Auto sequence track jump/move count setting (N)

Command	Data 1				Data 2				Data 3				Data 4			
	D3	D2	D1	D0	D3	D2	D1	D0	D3	D2	D1	D0	D3	D2	D1	D0
Auto sequence track jump count setting	2 ¹⁵	2 ¹⁴	2 ¹³	2 ¹²	2 ¹¹	2 ¹⁰	2 ⁹	2 ⁸	2 ⁷	2 ⁶	2 ⁵	2 ⁴	2 ³	2 ²	2 ¹	2 ⁰

This command is used to set N when a 2N-track jump or N-track move is executed for auto sequence.

- The maximum track count is 65,535, but note that with a 2N-track jump the maximum track jump count depends on the mechanical limitations of the optical system.
- The number of tracks jumped is counted according to the COUT signals.

\$8X commands

Command	Data 1				Data 2				Data 3			
	D3	D2	D1	D0	D3	D2	D1	D0	D3	D2	D1	D0
Mode specification	CDROM	DOUT Mute	DOUT ON/OFF	WSEL	VCO SEL1	0	SOCT	VCO SEL2	KSL3	KSL2	KSL1	KSL0

See "\$BX Commands".

Data 4				Data 5				Data 6			
D3	D2	D1	D0	D3	D2	D1	D0	D3	D2	D1	D0
0	0	VCO2 THRU	0	0	0	0	0	TXON	TXOUT	OUTL1	OUTL0

Command bit	C2PO timing	Processing
CDROM = 1	See Timing Chart 1-1.	CDROM mode; average value interpolation and pre-value hold are not performed.
CDROM = 0	See Timing Chart 1-1.	Audio mode; average value interpolation and pre-value hold are performed.

Command bit	Processing
DOUT Mute = 1	Digital Out output is muted. (DA output is not muted.)
DOUT Mute = 0	If other mute conditions are not set, Digital Out is not muted.

Command bit	Processing
DOUT ON/OFF = 1	Digital Out is output from the DOUT pin.
DOUT ON/OFF = 0	Digital Out is not output from the DOUT pin.

Command bit	Sync protection window width	Application
WSEL = 1	±26 channel clock*1	Anti-rolling is enhanced.
WSEL = 0	±6 channel clock	Sync window protection is enhanced.

*1 In normal-speed playback, channel clock = 4.3218MHz.

Command bit			Processing
VCOSEL1	KSL3	KSL2	
0	0	0	Multiplier PLL VCO1 is set to normal speed, and the output is 1/1 frequency-divided.
0	0	1	Multiplier PLL VCO1 is set to normal speed, and the output is 1/2 frequency-divided.
0	1	0	Multiplier PLL VCO1 is set to normal speed, and the output is 1/4 frequency-divided.
0	1	1	Multiplier PLL VCO1 is set to normal speed, and the output is 1/8 frequency-divided.
1	0	0	Multiplier PLL VCO1 is set to high speed*1, and the output is 1/1 frequency-divided.
1	0	1	Multiplier PLL VCO1 is set to high speed*1, and the output is 1/2 frequency-divided.
1	1	0	Multiplier PLL VCO1 is set to high speed*1, and the output is 1/4 frequency-divided.
1	1	1	Multiplier PLL VCO1 is set to high speed*1, and the output is 1/8 frequency-divided.

*1 Approximately twice the normal speed

Command bit			Processing
VCOSEL2	KSL1	KSL0	
0	0	0	Wide-band PLL VCO2 is set to normal speed, and the output is 1/1 frequency-divided.
0	0	1	Wide-band PLL VCO2 is set to normal speed, and the output is 1/2 frequency-divided.
0	1	0	Wide-band PLL VCO2 is set to normal speed, and the output is 1/4 frequency-divided.
0	1	1	Wide-band PLL VCO2 is set to normal speed, and the output is 1/8 frequency-divided.
1	0	0	Wide-band PLL VCO2 is set to high speed*2, and the output is 1/1 frequency-divided.
1	0	1	Wide-band PLL VCO2 is set to high speed*2, and the output is 1/2 frequency-divided.
1	1	0	Wide-band PLL VCO2 is set to high speed*2, and the output is 1/4 frequency-divided.
1	1	1	Wide-band PLL VCO2 is set to high speed*2, and the output is 1/8 frequency-divided.

*2 Approximately twice the normal speed

Command bit	Processing
VCO2 THRU = 0	V16M output is internally connected to VCKI. Set VCKI to low.
VCO2 THRU = 1	V16M output is not internally connected. Input the clock from VCKI.

* These bits select the internal or external connection for the VCO2 used in CAV-W mode.

Command bit	Processing
TXON = 0	When CD TEXT data is not demodulated, set TXON to 0.
TXON = 1	When CD TEXT data is demodulated, set TXON to 1.

* See "\$4-14. CD TEXT Data Demodulation"

Command bit	Processing
TXOUT = 0	Various signals except for CD TEXT is output from the SQSO pin.
TXOUT = 1	CD TEXT data is output from the SQSO pin.

* See "\$4-14. CD TEXT Data Demodulation"

Command bit	Processing
OUTL1 = 0	WFCK, XPCK C4M, WDCK and FSTO are output. The signal input to FSTI is supplied to the digital servo block.
OUTL1 = 1	WFCK, XPCK C4M, WDCK and FSTO outputs are set to low. FSTO and FSTI are internally connected. Set FSTI to low.

Command bit	Processing
OUTL0 = 0	PCMD, BCK, LRCK and EMPH are output.
OUTL0 = 1	PCMD, BCK, LRCK and EMPH outputs are low. PCMD and PCMDI, BCK and BCKI, LRCK and LRCKI and EMPH and EMPHI are internally connected. Set PCMDI, BCKI, LRCKI and EMPHI to low.

Timing Chart 1-1

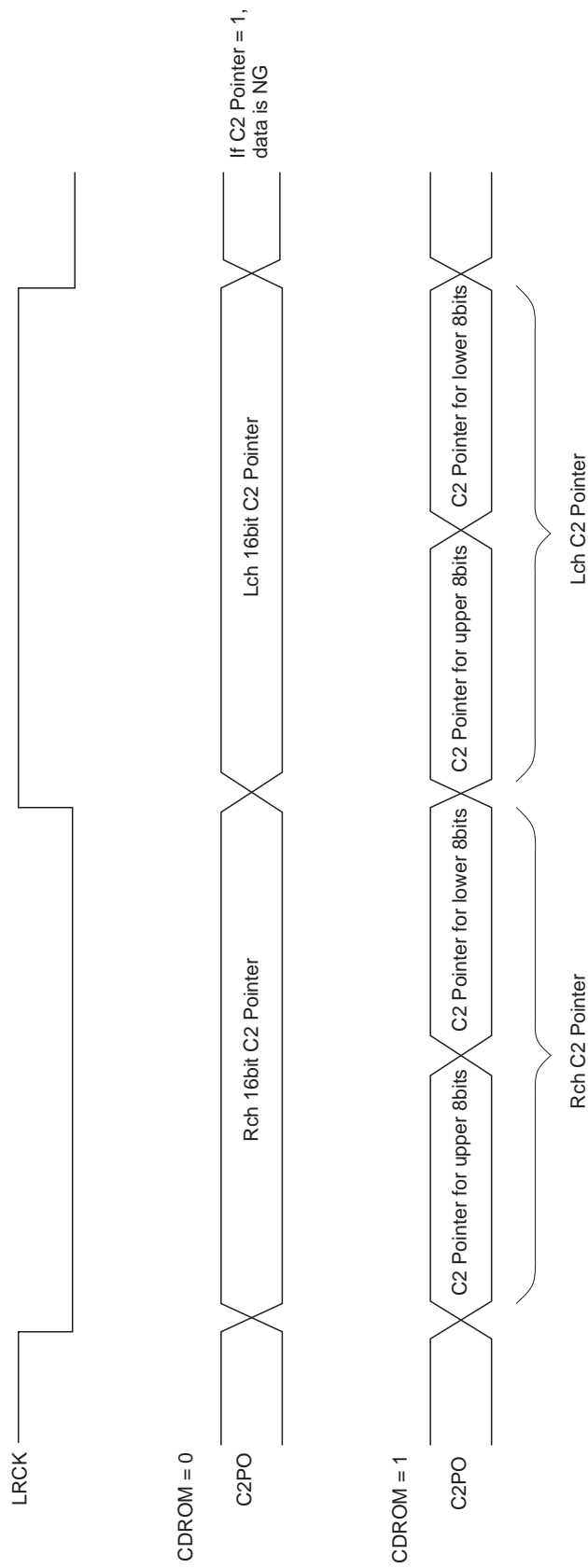

\$9X commands (OPSL1= 0)

* Data 2 D0 and subsequent data are for DF/DAC function settings.

Command	Data 1				Data 2		Data 3				Data 4			
	D3	D2	D1	D0	D3 to D1	D0	D3	D2	D1	D0	D3	D2	D1	D0
Function specification	0	DSPB ON/OFF	0	0	000	SYCOF	0	MCSL	0	0	ZDPL	ZMUT	—	—

OPSL1

Data 5			
D3	D2	D1	D0
—	—	—	—

\$9X commands (OPSL1= 1)

* Data 2 D0 and subsequent data are for DF/DAC function settings.

Command	Data 1				Data 2		Data 3				Data 4			
	D3	D2	D1	D0	D3 to D1	D0	D3	D2	D1	D0	D3	D2	D1	D0
Function specification	0	DSPB ON/OFF	0	0	000	SYCOF	1	MCSL	0	0	ZDPL	ZMUT	0	0

OPSL1

Data 5			
D3	D2	D1	D0
0	DCOF	0	0

Command bit	Processing
DSPB = 1	Double-speed playback (CD-DSP block)
DSPB = 0	Normal-speed playback (CD-DSP block)

Command bit	Processing
SYCOF = 1	LRCK asynchronous mode
SYCOF = 0	Normal operation

* Set SYCOF = 0 in advance when setting the \$AX command LRWO to 1.

Command bit	Processing
OPSL1 = 1	DCOF can be set.
OPSL1 = 0	DCOF cannot be set.

Command bit	Processing
MCSL = 1	DF/DAC block master clock selection. Crystal = 768Fs (33.8688MHz)
MCSL = 0	DF/DAC block master clock selection. Crystal = 384Fs (16.9344MHz)

Command bit	Processing
ZDPL = 1	LMUT and RMUT pins are high when muted.
ZDPL = 0	LMUT and RMUT pins are low when muted.

* See "Mute flag output" for the mute flag output conditions.

Command bit	Processing
ZMUT = 1	Zero detection mute is on.
ZMUT = 0	Zero detection mute is off.

Command bit	Processing
DCOF = 1	DC offset is off.
DCOF = 0	DC offset is on.

* DCOF can be set when OPSL1 = 1.

* Set DC offset to off when zero detection mute is on.

\$AX commands (OPSL2 = 0)

* Data 2 and subsequent data are for DF/DAC function settings.

Command	Data 1				Data 2				Data 3	
	D3	D2	D1	D0	D3	D2	D1	D0	D3	D2
Audio CTRL	0	0	Mute	ATT	0	0	0	EMPH	SMUT	0

OPSL2

Data 3		Data 4				Data 5				Data 6			
D1	D0	D3	D2	D1	D0	D3	D2	D1	D0	D3	D2	D1	D0
AD9	AD8	AD7	AD6	AD5	AD4	AD3	AD2	AD1	AD0	—	—	—	—

\$AX commands (OPSL2 = 1)

* Data 2 and subsequent data are for DF/DAC function settings.

Command	Data 1				Data 2				Data 3	
	D3	D2	D1	D0	D3	D2	D1	D0	D3	D2
Audio CTRL	0	0	Mute	ATT	0	0	1	EMPH	SMUT	0

OPSL2

Data 3		Data 4				Data 5				Data 6			
D1	D0	D3	D2	D1	D0	D3	D2	D1	D0	D3	D2	D1	D0
AD9	AD8	AD7	AD6	AD5	AD4	AD3	AD2	AD1	AD0	FMUT	LRWO	BSBST	BBSL

Command bit	Processing
Mute = 1	CD-DSP block mute is on. 0 data is output from the CD-DSP block.
Mute = 0	CD-DSP block mute is off.

Command bit	Processing
ATT = 1	CD-DSP block output is attenuated (-12dB).
ATT = 0	CD-DSP block output attenuation is off.

Command bit	Meaning
OPSL2 = 1	FMUT, LRWO, BSBST and BBSL can be set.
OPSL2 = 0	FMUT, LRWO, BSBST and BBSL cannot be set.

Command bit	Processing
EMPH = 1	De-emphasis is on.
EMPH = 0	De-emphasis is off.

* If either the EMPHI pin or EMPH is high, de-emphasis is on.

Command bit	Processing
SMUT = 1	Soft mute is on.
SMUT = 0	Soft mute is off.

* If either the SMUT pin or SMUT is high, soft mute is on.

Command bit	Meaning
AD10 to 0	Attenuation data.

The attenuation data consists of 11 bits, and is set as follows.

Attenuation data	Audio output
400h	0dB
3FEh	-0.0085dB
3FDh	-0.0170dB
:	
001h	-60.206dB
000h	-∞

The attenuation data (AD10 to AD0) consists of 11bits, and can be set in 1024 different ways in the range of 000h to 400h.

The audio output from 001h to 400h is obtained using the following equation.

$$\text{Audio output} = 20\log \frac{\text{Attenuation data}}{1024} \text{ [dB]}$$

Command bit	Meaning
FMUT = 1	Forced mute is on.
FMUT = 0	Forced mute is off.

* FMUT can be set when OP SL2 = 1.

Command bit	Meaning
LRWO = 1	Forced synchronization mode Note)
LRWO = 0	Normal operation.

* LRWO can be set when OP SL2 = 1.

Note) Synchronization is performed at the first falling edge of LRCK during reset, so there is normally no need to set this mode. However, synchronization can be forcibly performed by setting LRWO = 1.

Command bit	Processing
BSBST = 1	Bass boost is on.
BSBST = 0	Bass boost is off.

* BSBST can be set when OP SL2 = 1.

Command bit	Processing
BBSL = 1	Bass boost is Max.
BBSL = 0	Bass boost is Mid.

* BBSL can be set when OP SL2 = 1.

\$BX commands

Command	Data 1				Data 2			
	D3	D2	D1	D0	D3	D2	D1	D0
Serial bus CTRL	SL1	SL0	CPUSR	0	TRM1	TRM0	MTSL1	MTSLO

SOCT	SL1	SL0	mode
0	0	0	SubQ
0	0	1	Peak meter
0	1	0	SENS
0	1	1	D
1	0	0	SubQ
1	0	1	A
1	1	0	B
1	1	1	C

The SQSO pin output can be switched to the various signals by setting the SOCT command of \$8X and the SL1 and SL0 commands of \$BX. Set SQCK to high at the falling edge of XLAT.

Except for Sub Q and peak meter, the signals are loaded to the register when they are set at the falling edge of XLAT. Sub Q is loaded to the register with each SCOR, and Peak meter is loaded when a peak is detected.

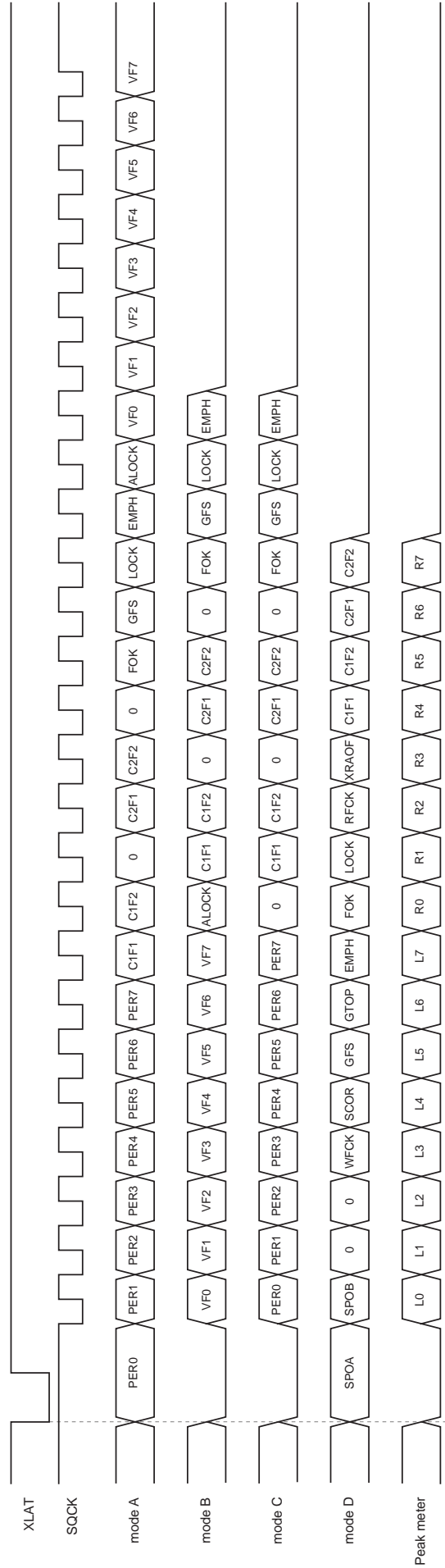

Signal	Description
PER0 to 7	RF jitter amount (used to adjust the focus bias). 8-bit binary data in PER0 = LSB, PER7 = MSB.
FOK	Focus OK
GFS	High when the frame sync and the insertion protection timing match.
LOCK	GFS is sampled at 460Hz; when GFS is high, a high signal is output. If GFS is low eight consecutive samples, a low signal is output.
EMPH	High when the playback disc has emphasis.
ALOCK	GFS is sampled at 460Hz; when GFS is high eight consecutive samples, a high signal is output. If GFS is low eight consecutive samples, a low signal is output.
VF0 to 7	Used in CAV-W mode. Results of measuring the disc rotational velocity. (See Timing Chart 2-3.) VF0 = LSB, VF7 = MSB.
SPOA, B	SPOA and B pin inputs.
WFCK	Write frame clock output.
SCOR	High when either subcode sync S0 or S1 is detected.
GTOP	High when the sync protection window is open.
RFCK	Read frame clock output.
XRAOF	Low when the built-in 16K RAM exceeds the ± 4 frame jitter margin.
L0 to L7, R0 to R7	Peak meter register output. L0 to 7 are the left-channel and R0 to 7 are the right-channel peak data. L0 and R0 are LSB.

C1F1	C1F2	C1 correction status
0	0	No Error
1	0	Single Error Correction
1	1	Irretrievable Error

C2F1	C2F2	C2 correction status
0	0	No Error
1	0	Single Error Correction
1	1	Irretrievable Error

Command bit	Processing
CPUSR = 1	XLON pin is high.
CPUSR = 0	XLON pin is low.

Peak meter

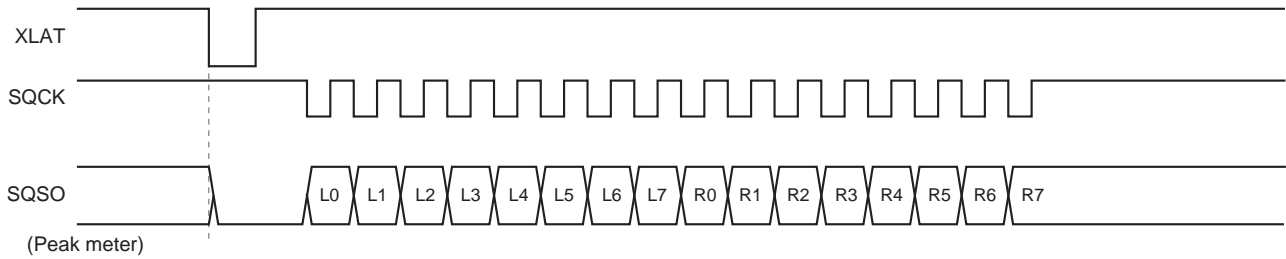

Setting the SOCT command of \$8X to 0 and the SL1 and SL0 commands of \$BX to 0 and 1, respectively, results in peak detection mode. The SQSO output is connected to the peak register. The maximum PCM data values (absolute value, upper 8bits) for the left and right channels can be read from SQSO by inputting 16 clocks to SQCK. Peak detection is not performed during SQCK input, and the peak register does not change during readout. This SQCK input judgment uses a retriggerable monostable multivibrator with a time constant of 270µs to 400µs. The time during which SQCK input is high should be 270µs or less. Also, peak detection is restarted 270µs to 400µs after SQCK input.

The peak register is reset with each readout (16 clocks input to SQCK). The maximum value in peak detection mode is detected and held in this status until the next readout. When switching to peak detection mode, readout should be performed one time initially to reset the peak register.

Peak detection can also be performed for previous value hold and average value interpolation data.

Traverse monitor count value setting

These bits are set when monitoring the traverse condition of the SENS output according to the COUT frequency division.

Command bit		Processing
TRM1	TRM0	
0	0	1/64 frequency division
0	1	1/128 frequency division
1	0	1/256 frequency division
1	1	1/512 frequency division

Monitor output switching

The monitor output can be switched to the various signals by setting the MTS1 and MTS0 commands of \$B.

Command bit		Output data			
		XUGF	XPCK	GFS	C2PO
MTSL1	MTSL0				
0	0	XUGF	XPCK	GFS	C2PO
0	1	MNT1	MNT0	MNT3	C2PO
1	0	RFCK	XPCK	XROF	GTOP

\$CX commands

Command	D3	D2	D1	D0
Servo coefficient setting	Gain MDP1	Gain MDP0	Gain MDS1	Gain MDS0
CLV CTRL (\$DX)				Gain CLVS

• CLV mode gain setting: GCLVS

Gain MDS1	Gain MDS0	Gain CLVS	GCLVS
0	0	0	-12dB
0	0	1	-6dB
0	1	0	-6dB
0	1	1	0dB
1	0	0	0dB
1	0	1	+6dB

• CLVP mode gain setting: GMDP: GMDS

Gain MDP1	Gain MDP0	GMDP
0	0	-6dB
0	1	0dB
1	0	+6dB

Gain MDS1	Gain MDS0	GMDS
0	0	-6dB
0	1	0dB
1	0	+6dB

\$DX commands

Command	Data 1				Data 2				Data 3			
	D3	D2	D1	D0	D3	D2	D1	D0	D3	D2	D1	D0
CLV CTRL	0	TB	TP	Gain CLVS	VP7	VP6	VP5	VP4	VP3	VP2	VP1	VP0

See the \$CX commands.

Command bit	Description
TB = 0	Bottom hold at a cycle of RFCK/32 in CLVS mode.
TB = 1	Bottom hold at a cycle of RFCK/16 in CLVS mode.
TP = 0	Peak hold at a cycle of RFCK/4 in CLVS mode.
TP = 1	Peak hold at a cycle of RFCK/2 in CLVS mode.

Command bit	Description
VP0 to 7 = F0 (H)	Playback at half (normal) speed to
:	
VP0 to 7 = E0 (H)	Playback at normal (double) speed to
:	
VP0 to 7 = C0 (H)	Playback at (quadruple) speed

The rotational velocity R of the spindle can be expressed with the following equation.

$$R = \frac{256 - n}{32}$$

R: Relative velocity at normal speed = 1
n: VP0 to 7 setting value

- Note)**
- Values in parentheses are for when DSPB is 1.
 - Values when crystal is 16.9344MHz and XTSL is low or when crystal is 33.8688MHz and XTSL is high.
 - VP0 to 7 setting values are valid in CAV-W mode.

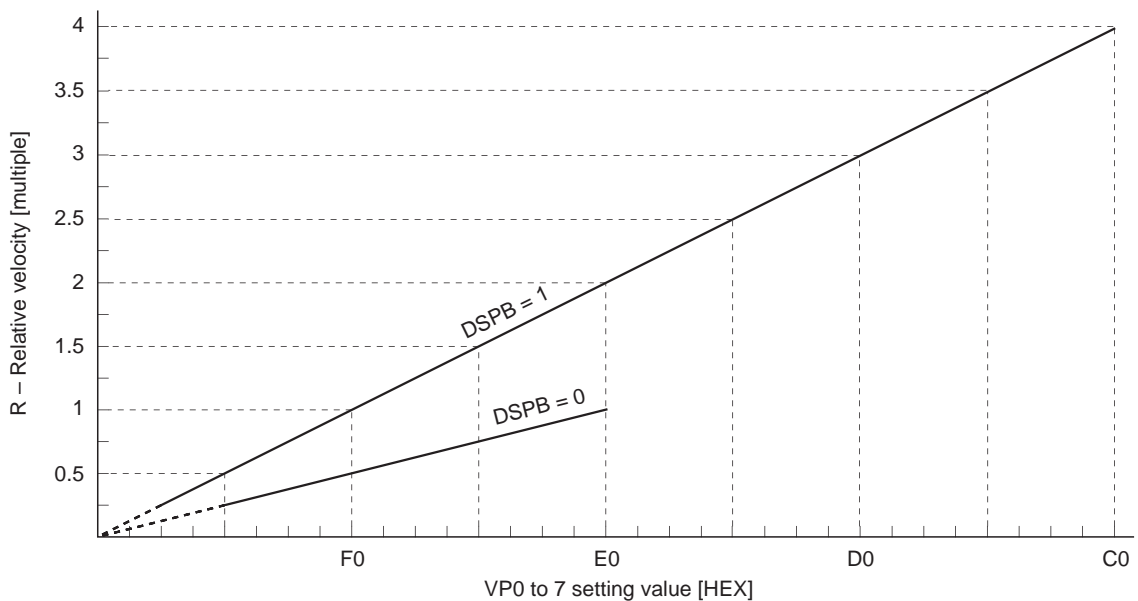

Fig. 1-1

\$EX commands

Command	Data 1				Data 2				Data 3			
	D3	D2	D1	D0	D3	D2	D1	D0	D3	D2	D1	D0
CLV mode	CM3	CM2	CM1	CM0	EPWM	SPDC	ICAP	SFSL	VC2C	HIFC	LPWR	VPON

Command bit				Mode	Description
CM3	CM2	CM1	CM0		
0	0	0	0	STOP	Spindle stop mode.*1
1	0	0	0	KICK	Spindle forward rotation mode.*1
1	0	1	0	BRAKE	Spindle reverse rotation mode. Valid only when LPWR = 0 in any mode.*1
1	1	1	0	CLVS	Rough servo mode. When the RF-PLL circuit isn't locked, this mode is used to pull the disc rotations within the RF-PLL capture range.
1	1	1	1	CLVP	PLL servo mode.
0	1	1	0	CLVA	Automatic CLVS/CLVP switching mode. Used for normal playback.

*1 See Timing Charts 1-2 to 1-6.

Command bit								Mode	Description
EPWM	SPDC	ICAP	SFSL	VC2C	HIFC	LPWR	VPON		
0	0	0	0	0	0	0	0	CLV-N	Crystal reference CLV servo.
0	0	0	0	1	1	0	0	CLV-W	Used for normal-speed playback in CLV-W mode.*2
0	1	1	0	0	1	0	1	CAV-W	Spindle control with VP0 to 7.
1	0	1	0	0	1	0	1	CAV-W	Spindle control with the external PWM.

*2 Figs. 3-1 and 3-2 show the control flow with the microcomputer software in CLV-W mode.

Command	Data 4			
	D3	D2	D1	D0
SPD mode	Gain CAV1	Gain CAV0	0	0

Gain CAV1	Gain CAV0	Gain
0	0	0dB
0	1	-6dB
1	0	-12dB
1	1	-18dB

- This sets the gain when controlling the spindle with the phase comparator in CAV-W mode.

Mode	LPWR	Command	Timing chart
CLV-N	0	KICK	1-2 (a)
		BRAKE	1-2 (b)
		STOP	1-2 (c)
CLV-W	0	KICK	1-3 (a)
		BRAKE	1-3 (b)
		STOP	1-3 (c)
	1	KICK	1-4 (a)
		BRAKE	1-4 (b)
		STOP	1-4 (c)
CAV-W	0	KICK	1-5 (a)
		BRAKE	1-5 (b)
		STOP	1-5 (c)
	1	KICK	1-6 (a)
		BRAKE	1-6 (b)
		STOP	1-6 (c)

Mode	LPWR	Timing chart
CLV-N	0	1-7
CLV-W	0	1-8
	1	1-9
CAV-W	0	1-10 (EPWM = 0)
	1	1-11 (EPWM = 0)
	0	1-12 (EPWM = 1)
	1	1-13 (EPWM = 1)

Timing Chart 1-2

CLV-N mode LPWR = 0

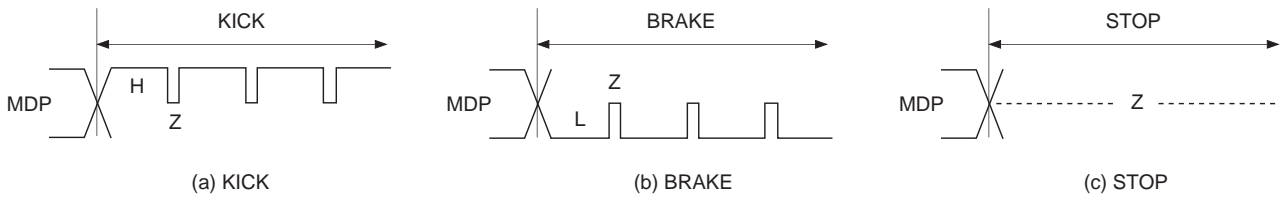

Timing Chart 1-3

CLV-W mode (when following the spindle rotational velocity) LPWR = 0

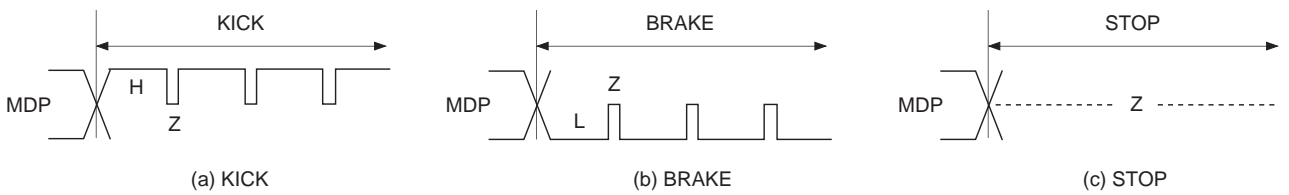

Timing Chart 1-4

CLV-W mode (when following the spindle rotational velocity) LPWR = 1

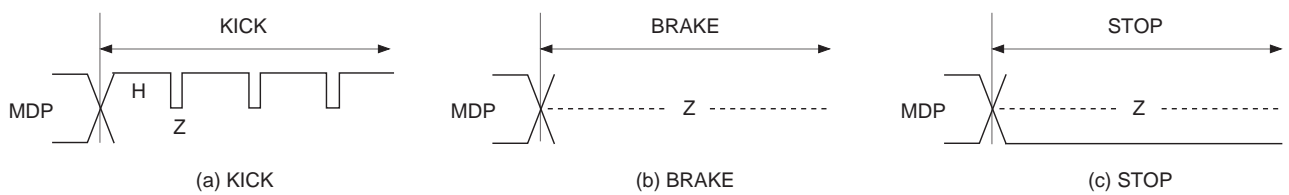

Timing Chart 1-5

CAV-W mode LPWR = 0

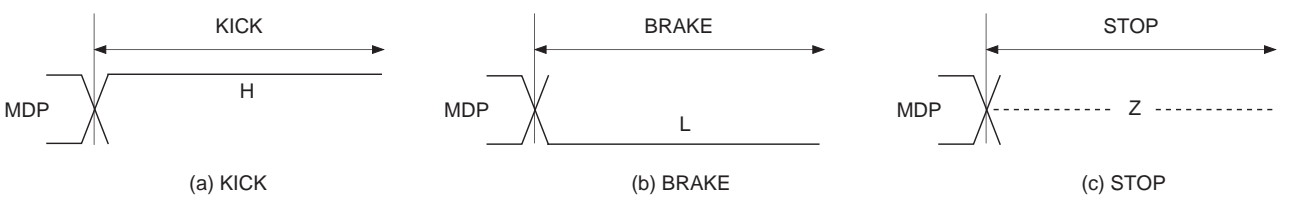

Timing Chart 1-6

CAV-W mode LPWR = 1

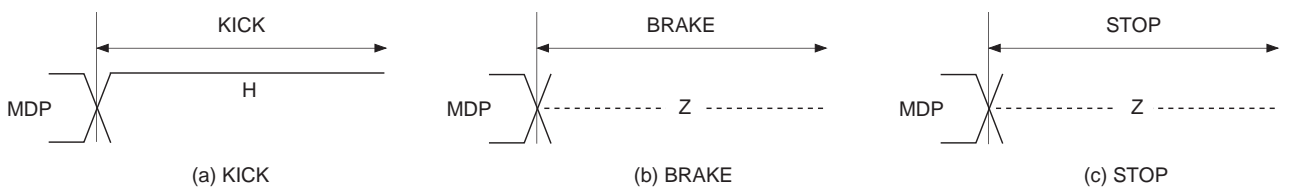

Timing Chart 1-7

CLV-N mode LPWR = 0

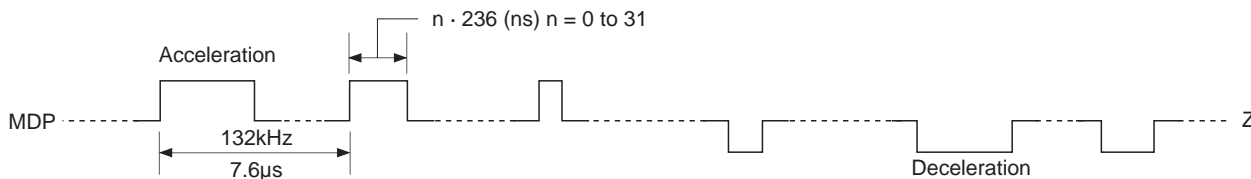

Timing Chart 1-8

CLV-W mode LPWR = 0

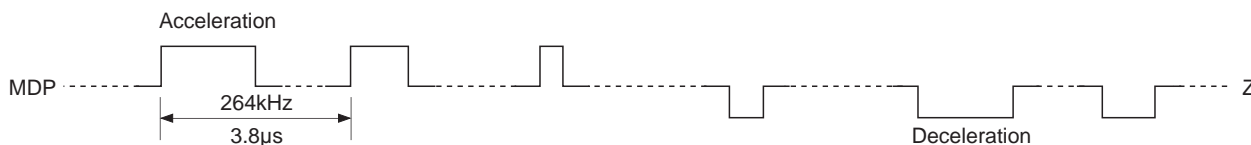

Timing Chart 1-9

CLV-W mode LPWR = 1

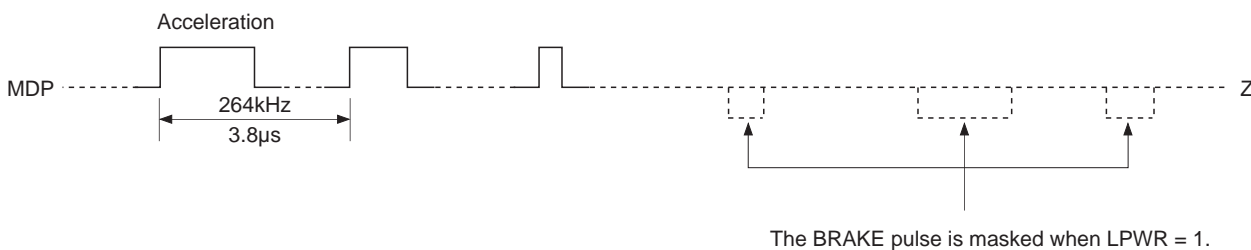

Timing Chart 1-10

CAV-W mode EPWM = LPWR = 0

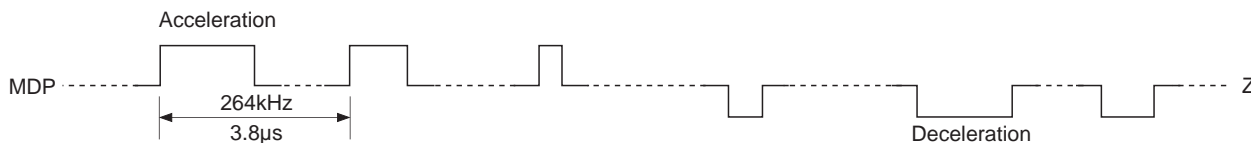

Timing Chart 1-11

CAV-W mode EPWM = LPWR = 1

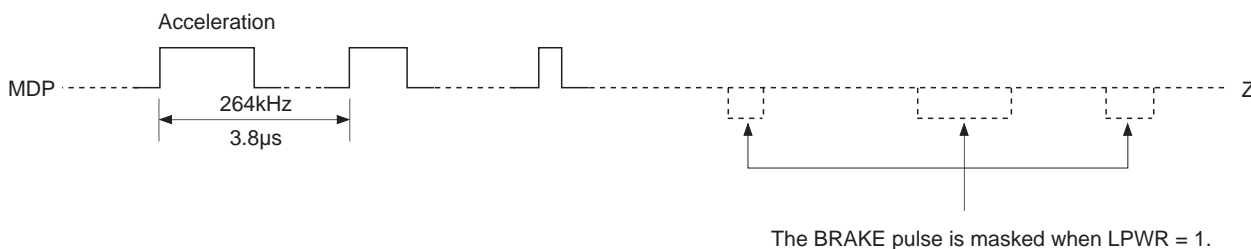

Timing Chart 1-12

CAV-W mode EPWM = 1, LPWR = 0

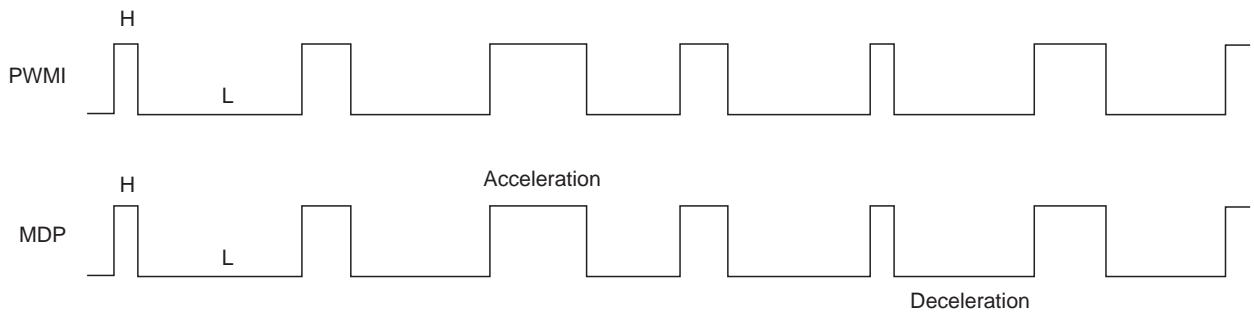

Timing Chart 1-13

CAV-W mode EPWM = LPWR = 1

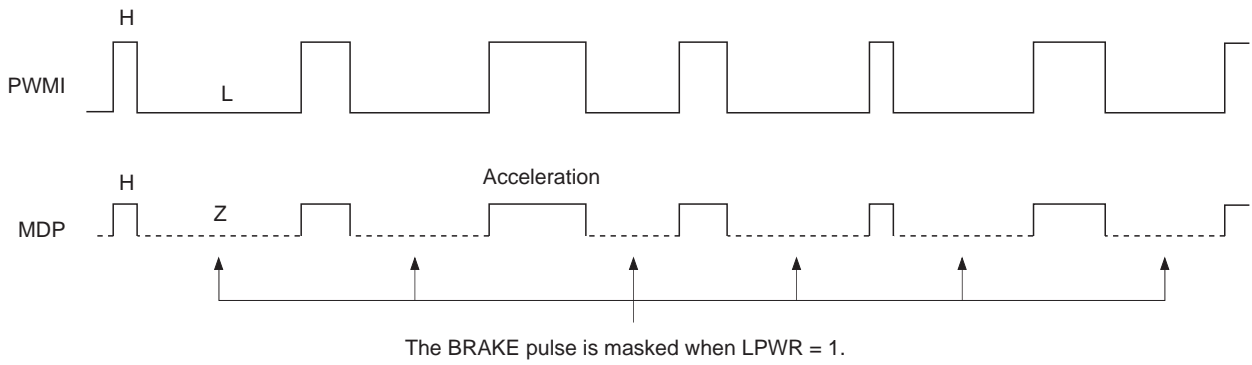

§2. Subcode Interface

This section explains the subcode interface.

There are two methods for reading out a subcode externally.

The 8-bit subcodes P to W can be read from SBSO by inputting EXCK to the CXD2588Q/R.

Sub Q can be readout after checking the CRC of the 80 bits in the subcode frame.

Sub Q can be readout from the SQSO pin by inputting 80 clock pulses to the SQCK pin when SCOR comes correctly and CRCF is high.

§2-1. P to W Subcode Readout

Data can be readout by inputting EXCK immediately after WFCK falls. (See Timing Chart 2-1.)

§2-2. 80-bit Sub Q Readout

Fig. 2-1 shows the peripheral block of the 80-bit Sub Q register.

- First, Sub Q, regenerated at one bit per frame, is input to the 80-bit serial/parallel register and the CRC check circuit.
- 96-bit Sub Q is input, and if the CRC is OK, it is output to SQSO with $CRCF = 1$. In addition, 80 bits are loaded into the parallel/serial register.
When SQSO goes high $400\mu\text{s}$ (monostable multivibrator time constant) or more after subcode readout, the CPU determines that new data (which passed the CRC check) has been loaded.
- The CRCF reset is performed by inputting SQCK. When the subcode data is discontinuous after track jump, etc. CRCF is reset by inputting SQCK. Then, if $CRCF = 1$, the CPU determines that the new data has been loaded.
- When the 80-bit data is loaded, the order of the MSB and LSB is inverted within each byte. As a result, although the sequence of bytes is the same, the bits within the bytes are now ordered LSB first.
- Once the 80-bit data load is confirmed, SQCK is input so that the data can be read.
The SQCK input is detected, and the retriggerable monostable multivibrator is reset while the input is low.
- The retriggerable monostable multivibrator has a time constant from $270\mu\text{s}$ to $400\mu\text{s}$. When the duration when SQCK is high is less than this time constant, the monostable multivibrator is kept reset; during this interval, the serial/parallel register is not loaded into the parallel/serial register.
- While the monostable multivibrator is being reset, data cannot be loaded in the 80-bit parallel/serial register.
In other words, while reading out with a clock cycle shorter than this time constant, the register will not be rewritten by CRCOK and others. (See Timing Chart 2-2.)
- The high and low intervals for SQCK should be between 750ns and $120\mu\text{s}$.

Timing Chart 2-1

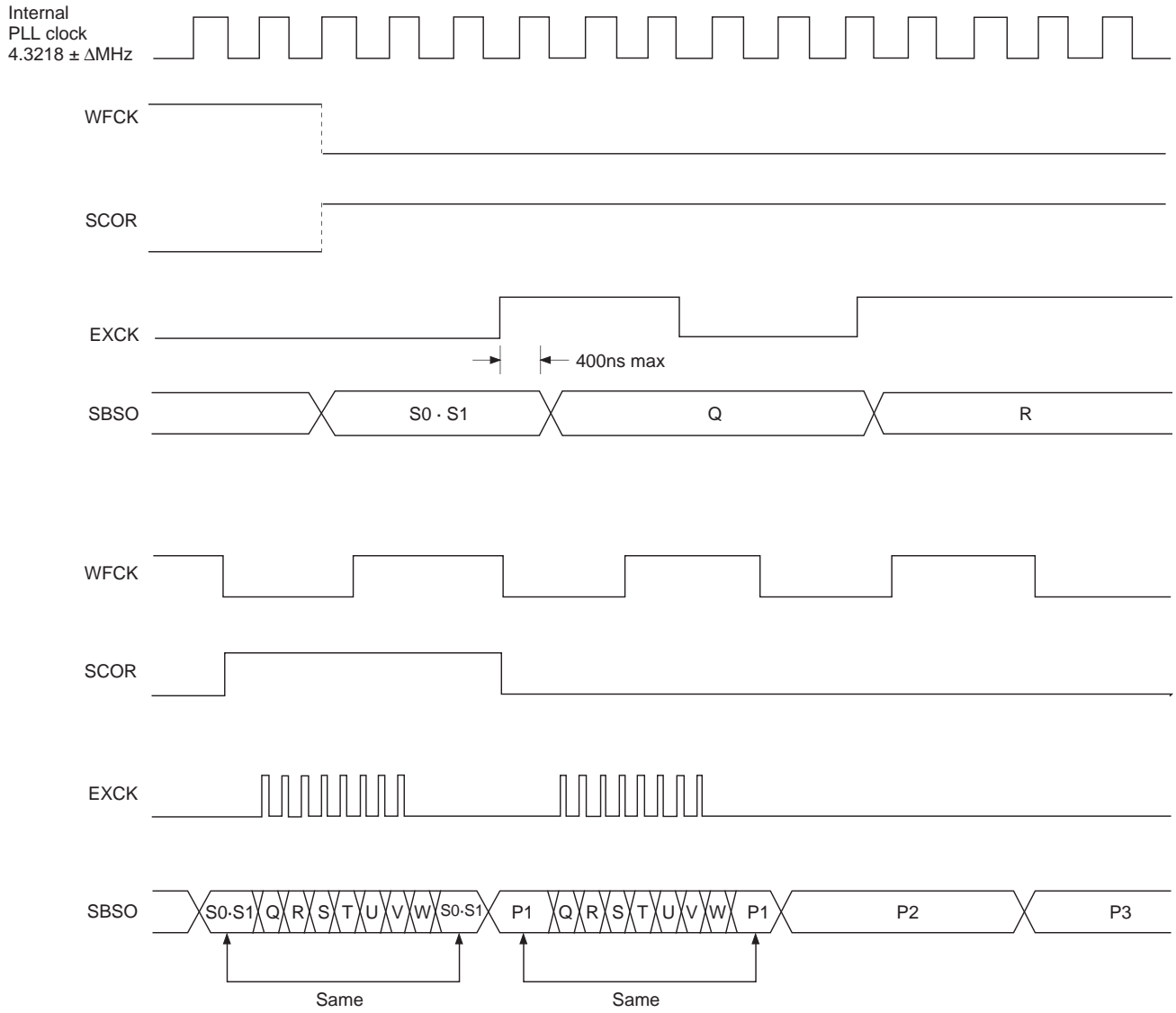

Sub Code P.Q.R.S.T.U.V.W Read Timing

Fig. 2-1. Block Diagram

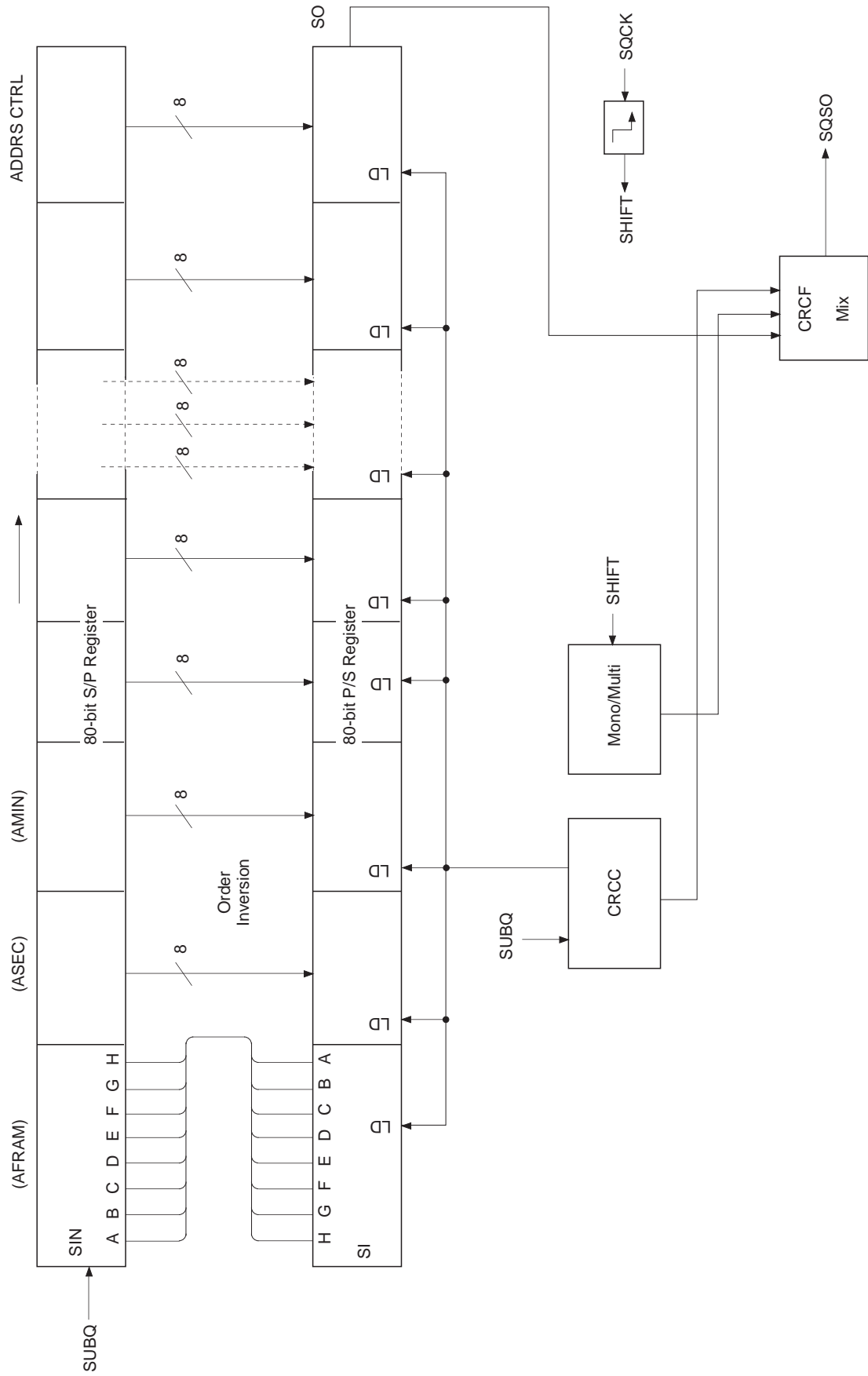

Timing Chart 2-2

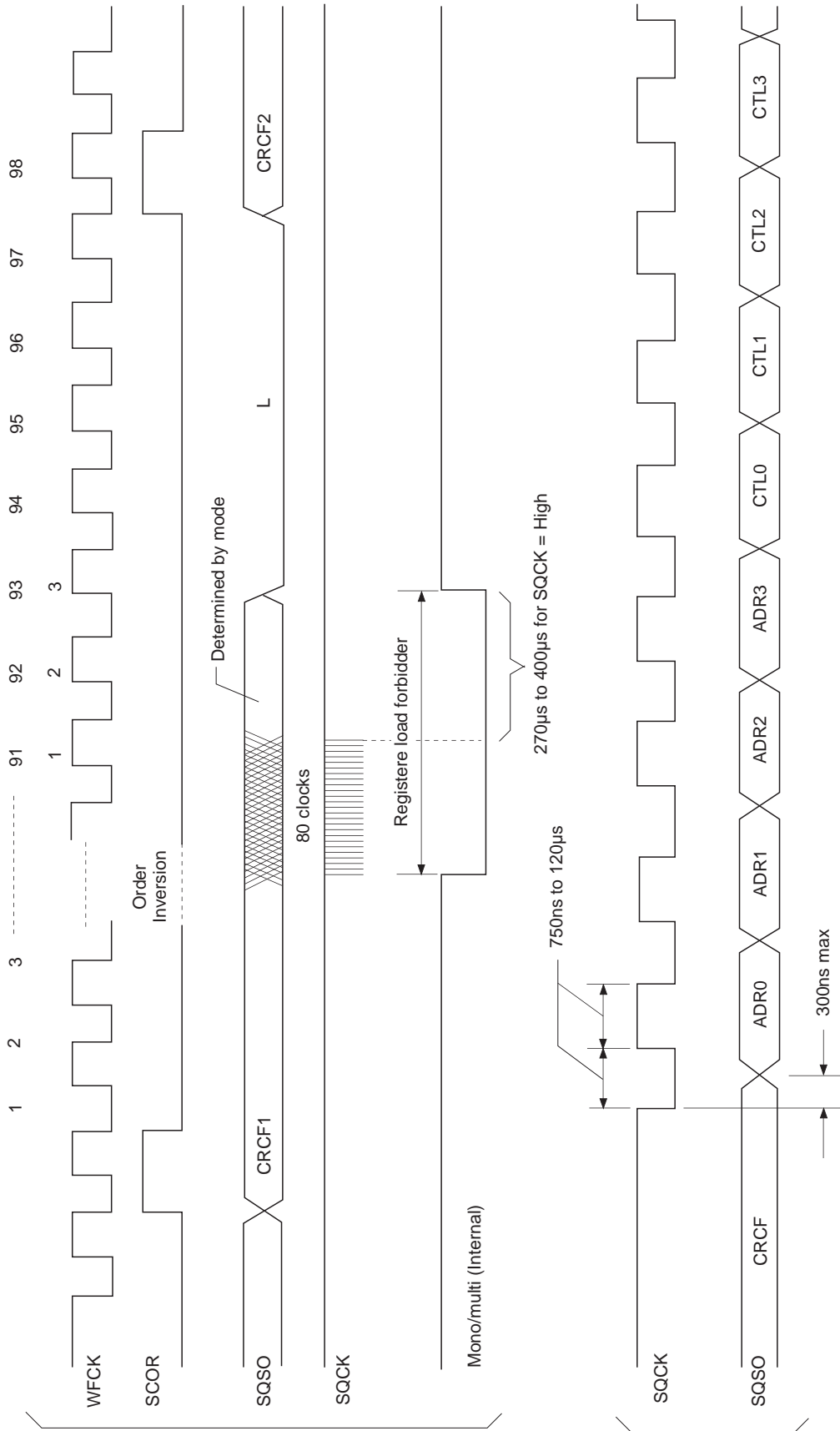

Timing Chart 2-3

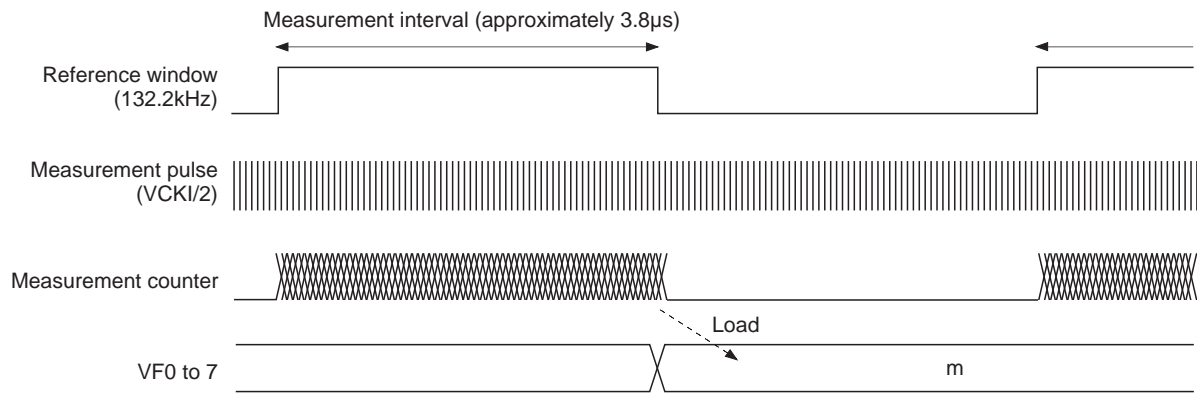

The relative velocity R of the disc can be expressed with the following equation.

$$R = \frac{m + 1}{32} \quad (\text{R: Relative velocity, m: Measurement results})$$

VF0 to 7 is the result obtained by counting VCKI/2 pulses while the reference signal (132.2kHz) generated from the crystal (384Fs) is high. This count is 31 when the disc is rotating at normal speed and 63 when it is rotating at double speed (when DSPB is low).

§3. Description of Modes

This LSI has three basic operating modes using a combination of spindle control and the PLL. The operations for each mode are described below.

§3-1. CLV-N Mode

This mode is compatible with the CXD2507AQ, and operation is the same as for the conventional control. The PLL capture range is $\pm 150\text{kHz}$.

§3-2. CLV-W Mode

This is the wide capture range mode. This mode allows the PLL to follow the rotational velocity of the disc. This rotational following control has two types: using the built-in VCO2 or providing an external VCO. The spindle is the same CLV servo as for the conventional series. Operation using the built-in VCO2 is described below. (When using an external VCO, input the signal from the VPCO pin to the low-pass filter, use the output from the low-pass filter as the control voltage for the external VCO, and input the oscillation output from the VCO to the VCKI pin.)

When starting to rotate the disc and/or speeding up to the lock range from the condition where the disc is stopped, CAV-W mode should be used. Specifically, first send $\$E6650$ to set CAV-W mode and kick the disc, then send $\$E60C0$ to set CLV-W mode if ALOCK is high, which can be readout serially from the SQSO pin. CLV mode can be used while ALOCK is high. The microcomputer monitors the serial data output, and must return the operation to the speed adjusting state (CAV-W mode) when ALOCK becomes low. The control flow according to the microcomputer software is shown in Fig. 3-2.

In CLV-W mode (normal), low power consumption is achieved by setting LPWR to high. Control was formerly performed by applying acceleration and deceleration pulses to the spindle motor. However, when LPWR is set to high, deceleration pulses are not output, thereby achieving low power consumption mode.

Note) The capture range for CLV-W mode has theoretically the range up to the signal processing limit.

§3-3. CAV-W Mode

This is CAV mode. In this mode, the external clock is fixed and it is possible to control the spindle to variable rotational velocity. The rotational velocity is determined by the VP0 to 7 setting values or the external PWM. When controlling the spindle with VP0 to 7, setting CAV-W mode with the $\$E6650$ command and controlling VP0 to 7 with the $\$DX$ commands allows the rotational velocity to be varied from low speed to double speed. (See the $\$DX$ commands.) Also, when controlling the spindle with the external PWM, the PWMI pin is binary input which becomes KICK during high intervals and BRAKE during low intervals.

The microcomputer can know the rotational velocity using V16M. The reference for the velocity measurement is a signal of 132.2kHz obtained by 1/128-frequency dividing the crystal (384Fs). The velocity is obtained by counting V16M/2 pulses while the reference is high, and the result is output from the new CPU interface as 8 bits (VF0 to 7). These measurement results are 31 when the disc is rotating at normal speed or 63 when it is rotating at double speed. These values match those of the 256-n for control with VP0 to 7.

In CAV-W mode, the spindle is set to the desired rotational velocity and the operation speed for the entire system follows this rotational velocity. Therefore, the cycles for the Fs system clock, PCM data and all other output signals from this LSI change according to the rotational velocity of the disc.

Note) The capture range for this mode is theoretically up to the signal processing limit.

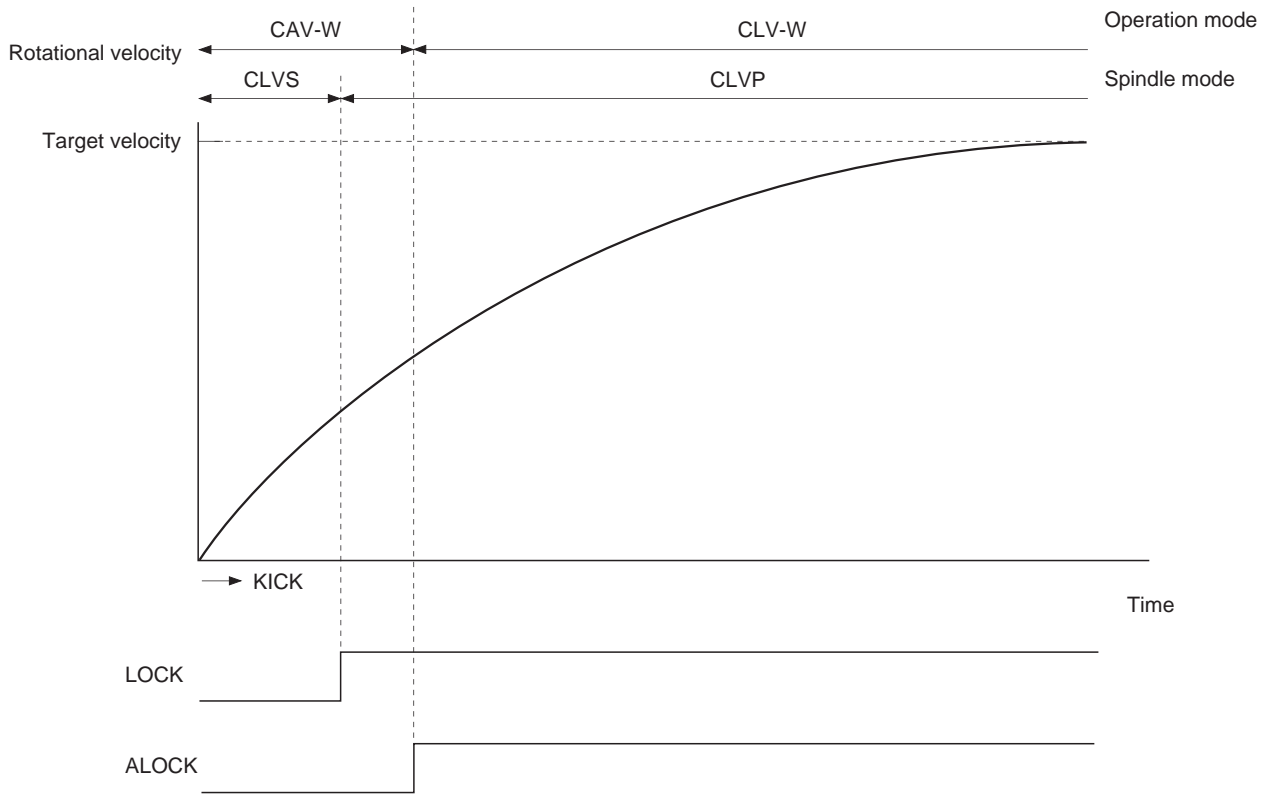

Fig. 3-1. Disc Stop to Normal Condition in CLV-W Mode

CLV-W Mode

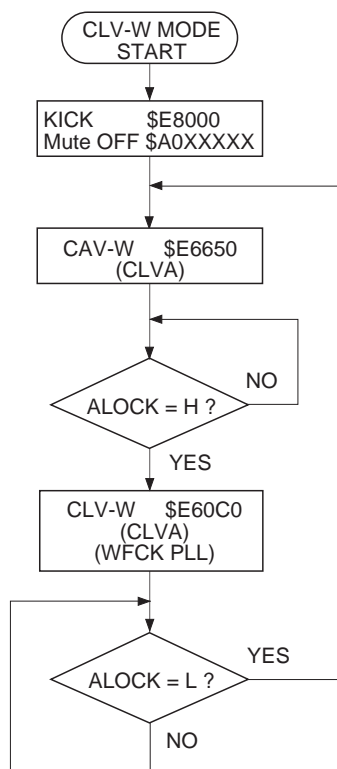

Fig. 3-2. CLV-W Mode Flow Chart

§4. Description of Other Functions

§4-1. Channel Clock Regeneration by the Digital PLL Circuit

- The channel clock is necessary for demodulating the EFM signal regenerated by the optical system. Assuming T as the channel clock cycle, the EFM signal is modulated in an integer multiple of T from $3T$ to $11T$. In order to read the information in the EFM signal, this integer value must be read correctly. As a result, T , that is the channel clock, is necessary. In an actual player, the PLL is necessary to regenerate the channel clock because the fluctuation in the spindle rotation alters the width of the EFM signal pulses.

The block diagram of this PLL is shown in Fig. 4-1.

The CXD2588Q/R has a built-in three-stage PLL.

- The first-stage PLL is for the wide-band PLL. When the internal VCO2 is used, an external LPF is necessary; when not using the internal VCO2, external LPF and VCO are required. The output of this first-stage PLL is used as a reference for all clocks within the LSI.
- The second-stage PLL generates the high-frequency clock needed by the third-stage digital PLL.
- The third-stage PLL is a digital PLL that regenerates the actual channel clock.
- A new digital PLL has been provided for CLV-W mode to follow the rotational velocity of the disc in addition to the conventional secondary loop.

Block Diagram 4-1

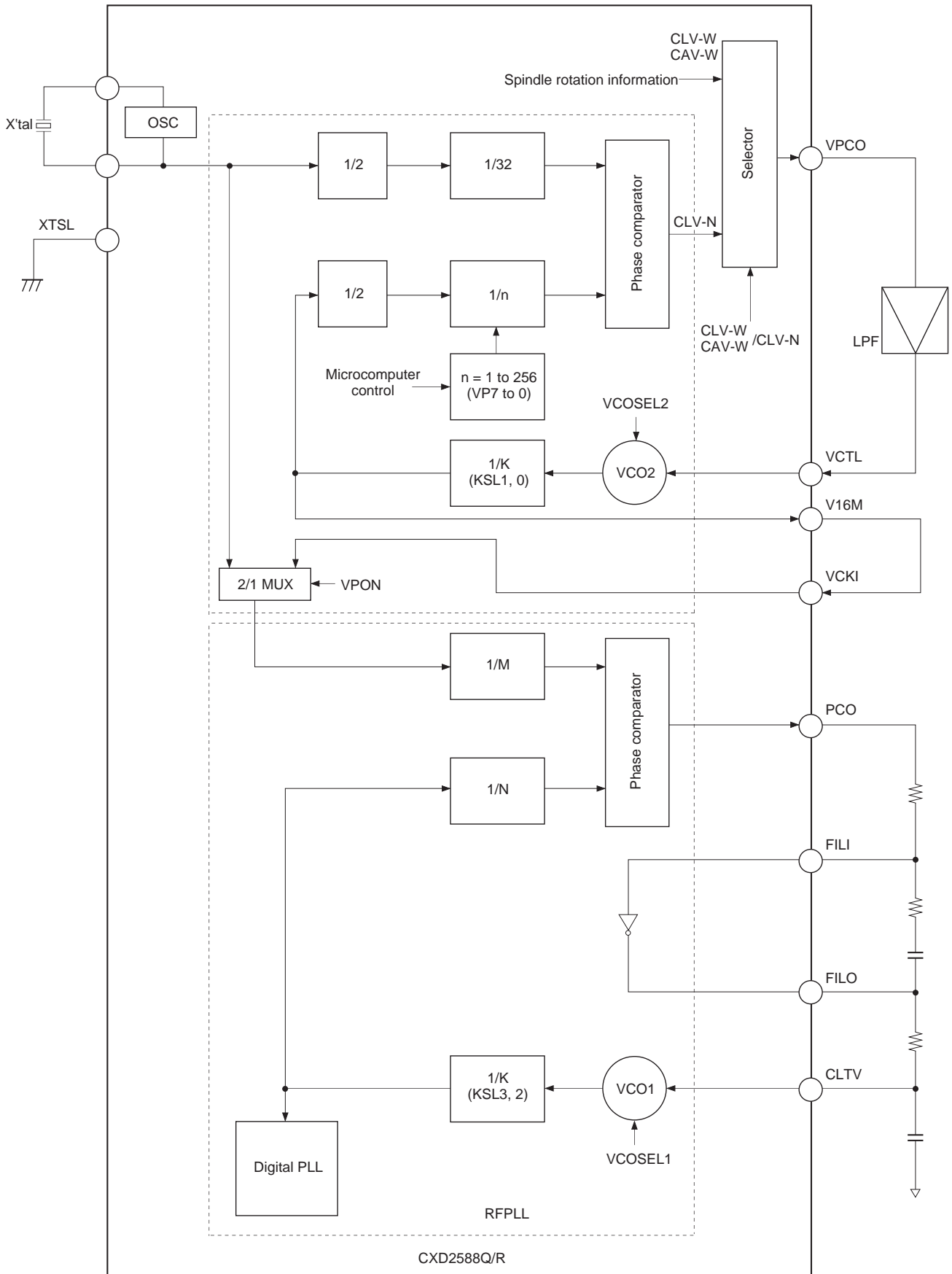

§4-2. Frame Sync Protection

- In normal-speed playback, a frame sync is recorded approximately every 136 μ s (7.35kHz). This signal is used as a reference to recognize the data within a frame. Conversely, if the frame sync cannot be recognized, the data is processed as error data because the data cannot be recognized. As a result, recognizing the frame sync properly is extremely important for improving playability.
- In the CXD2588Q/R, window protection and forward protection/backward protection have been adopted for frame sync protection. These functions achieve very powerful frame sync protection. There are two window widths: one for cases where a rotational disturbance affects the player and the other for cases where there is no rotational disturbance (WSEL = 0/1). In addition, the forward protection counter is fixed to 13, and the backward protection counter to 3. Concretely, when the frame sync is being played back normally and then cannot be detected due to scratches etc., a maximum of 13 frames are inserted. If the frame sync cannot be detected for 13 frames or more, the window opens to resynchronize the frame sync. In addition, immediately after the window opens and the resynchronization is executed, if a proper frame sync cannot be detected within 3 frames, the window opens immediately.

§4-3. Error Correction

- In the CD format, one 8-bit data contains two error correction codes, C1 and C2. For C1 correction, the code is created with 28-byte information and 4-byte C1 parity. For C2 correction, the code is created with 24-byte information and 4-byte parity. Both C1 and C2 are Reed-Solomon codes with a minimum distance of 5.
- The CXD2588Q/R's SEC strategy uses powerful frame sync protection and C1 and C2 error correction to achieve high playability.
- The correction status can be monitored externally. See Table 4-2.
- When the C2 pointer is high, the data in question was uncorrectable. Either the pre-value was held or an average value interpolation was made for the data.

MNT3	MNT1	MNT0	Description
0	0	0	No C1 errors
0	0	1	One C1 error corrected
0	1	1	C1 correction impossible
1	0	0	No C2 errors
1	0	1	One C2 error corrected
1	1	0	C2 correction impossible

Table 4-2.

Timing Chart 4-3

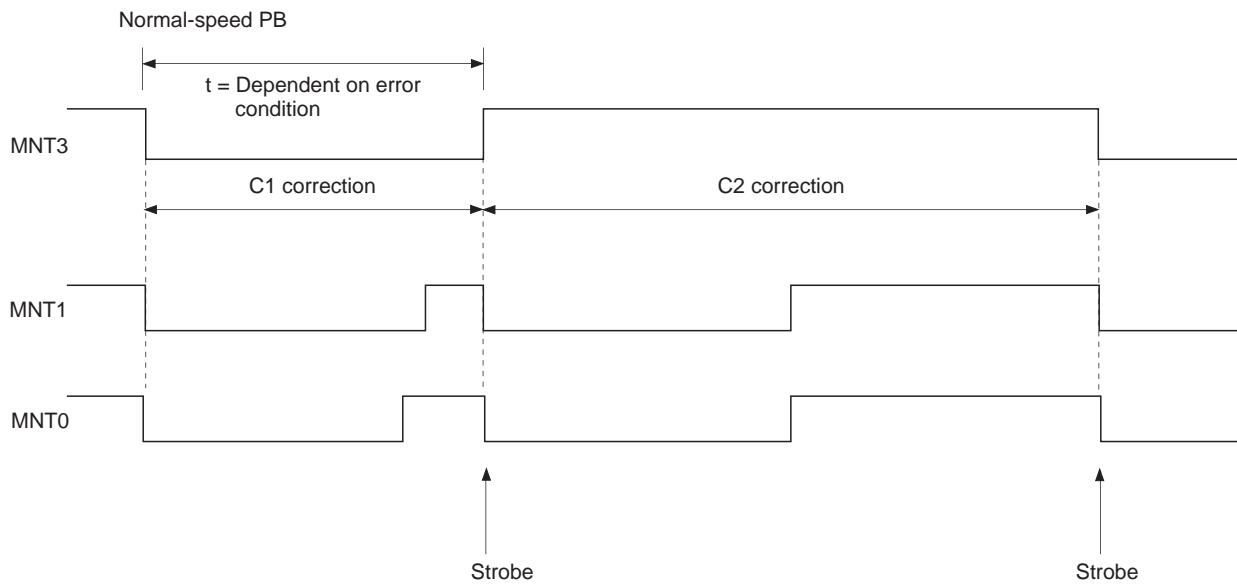

§4-4. DA Interface

- The CXD2588Q/R DA interface is as described below.

This interface includes 48 cycles of the bit clock within one LRCK cycle, and is MSB first. When LRCK is high, the data is for the left channel.

Timing Chart 4-4

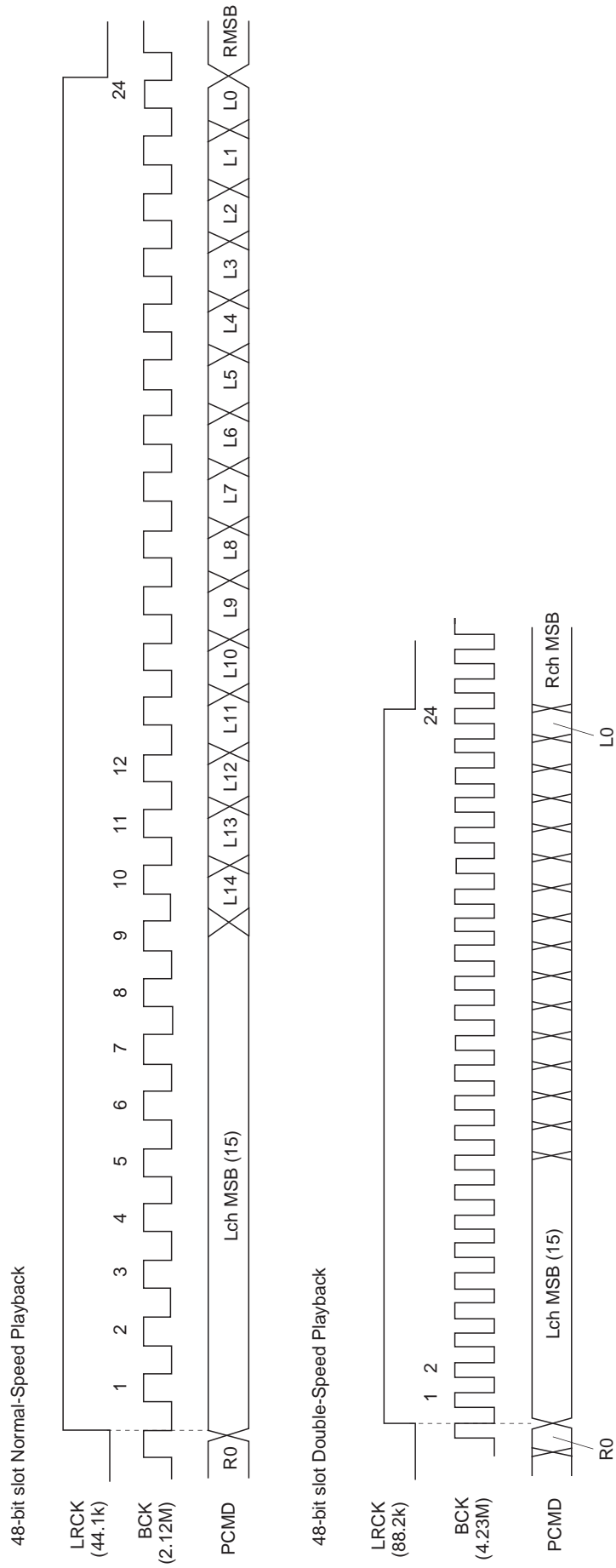

§4-5. Digital Out

There are three Digital Out: the type 1 format for broadcasting stations, the type 2 form 1 format for home use, and the type 2 form 2 format for the manufacture of software.

The CXD2588Q/R supports type 2 form 1.

Sub Q data which are matched twice in succession after a CRC check are input to the first four bits (bits 0 to 3) of the channel status.

Digital Out C bit

	0	1	2	3	4	5	6	7	8	9	10	11	12	13	14	15
0	From sub Q				0	0	0	0	1	0	0	0	0	0	0	0
	ID0	ID1	COPY	Emph												
16	0	0	0	0	0	0	0	0	0	0	0	0	0	0/1	0	0
32	0															
48																
176																

Bits 0 to 3 Sub Q control bits that matched twice with CRCOK
 Bit 29 1 when VPON = 1

Table 4-5.

§4-6. Servo Auto Sequence

This function performs a series of controls, including auto focus and track jumps. When the auto sequence command is received from the CPU, auto focus, 1-track jump, 2N-track jump and N-track move are executed automatically.

The commands which enable transfer to the CXD2588Q/R during the execution of auto sequence are \$4X to \$EX.

When CLOK goes from low to high while XBUSY is low, XBUSY does not become high for a maximum of 100µs after that point.

(a) Auto focus (\$47)

Focus search-up is performed, FOK and FZC are checked, and the focus servo is turned on.

If \$47 is received from the CPU, the focus servo is turned on according to Fig. 4-3. The auto focus starts with focus search-up, and note that the pickup should be lowered beforehand (focus search down). In addition, blind E of register 5 is used to eliminate FZC chattering. Concretely, the focus servo is turned on at the falling edge of FZC after FZC has been continuously high for a longer time than E.

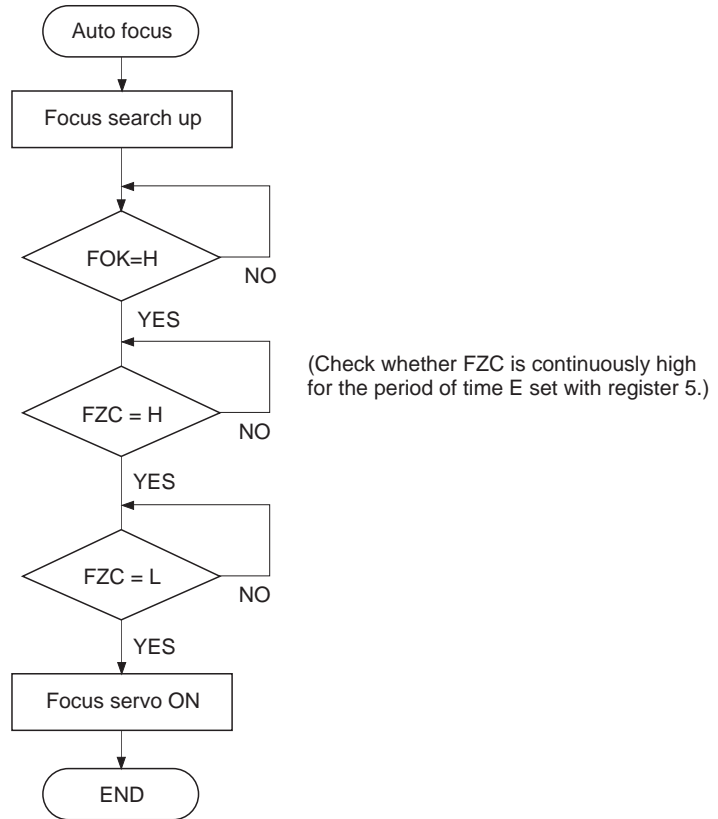

Fig. 4-6-(a). Auto Focus Flow Chart

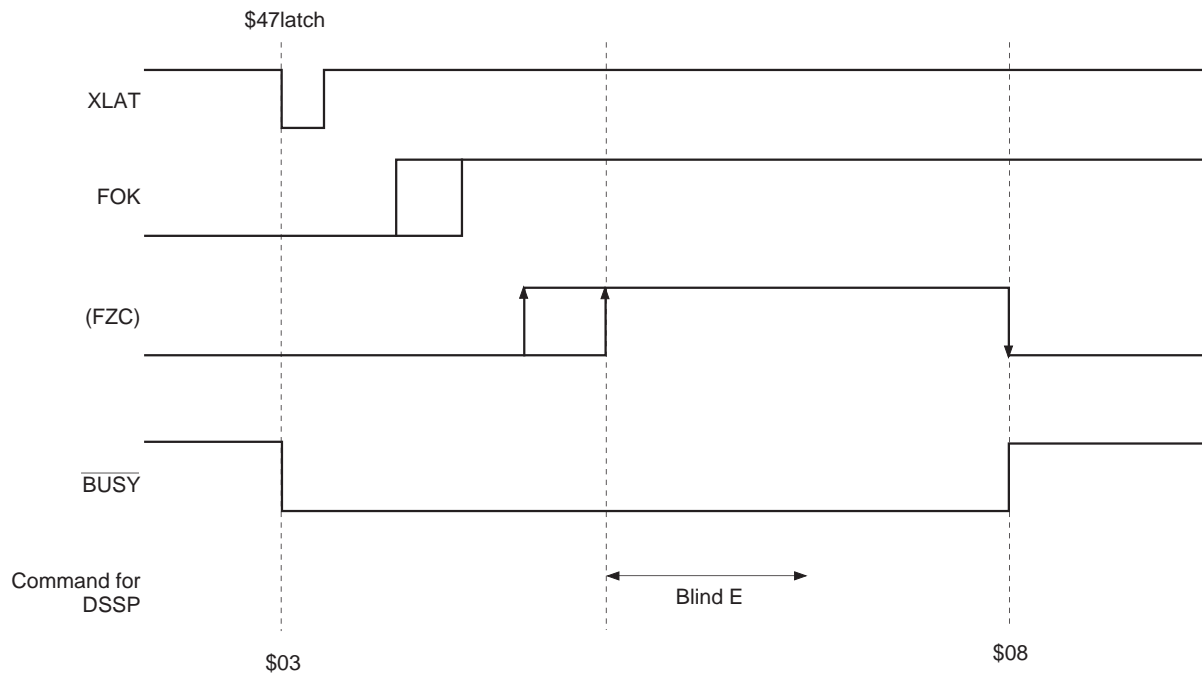

Fig. 4-6-(b). Auto Focus Timing Chart

(b) Track jump

1, 10 and 2N-track jumps are performed respectively. Always use this when the focus, tracking, and sled servos are on. Note that tracking gain-up and braking-on should be sent beforehand because they are not involved in this sequence.

- 1-track jump

When \$48 (\$49 for REV) is received from the CPU, a FWD (REV) 1-track jump is performed in accordance with Fig. 4-7. Set blind A and brake B with register 5.

- 10-track jump

When \$4A (\$4B for REV) is received from the CPU, a FWD (REV) 10-track jump is performed in accordance with Fig. 4-8. The principal difference from the 1-track jump is to kick the sled. In addition, after kicking the actuator, when 5 tracks have been counted through COUT, the brake is applied to the actuator. Then, when the actuator speed is found to have slowed up enough (determined by the COUT cycle becoming longer than the overflow C set with register 5), the tracking and sled servos are turned on.

- 2N-track jump

When \$4C (\$4D for REV) is received from the CPU, a FWD (REV) 2N-track jump is performed in accordance with Fig. 4-9. The track jump count N is set with register 7. Although N can be set to 2^{16} tracks, note that the setting is actually limited by the actuator. COUT is used for counting the number of jumps.

Although the 2N-track jump basically follows the same sequence as the 10-track jump, the one difference is that after the tracking servo is turned on, the sled continues to move only for "D", set with register 6.

- N-track move

When \$4E (\$4F for REV) is received from the CPU, a FWD (REV) N-track move is performed in accordance with Fig. 4-10. N can be set to 2^{16} tracks. COUT is used for counting the number of jumps. The N-track move is executed only by moving the sled, and is therefore suited for moving across several thousand to several ten-thousand tracks.

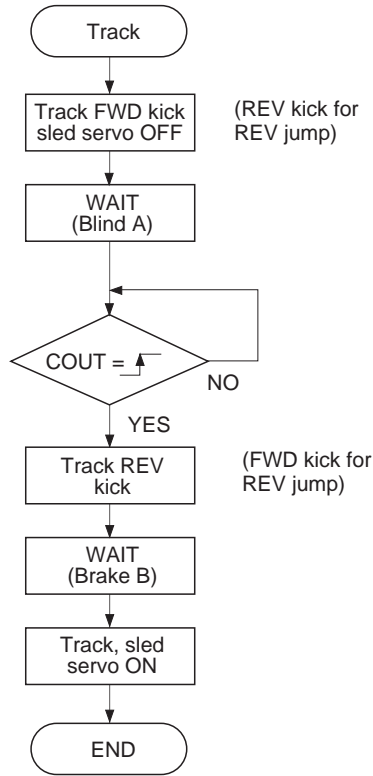

Fig. 4-7-(a). 1-Track Jump Flow Chart

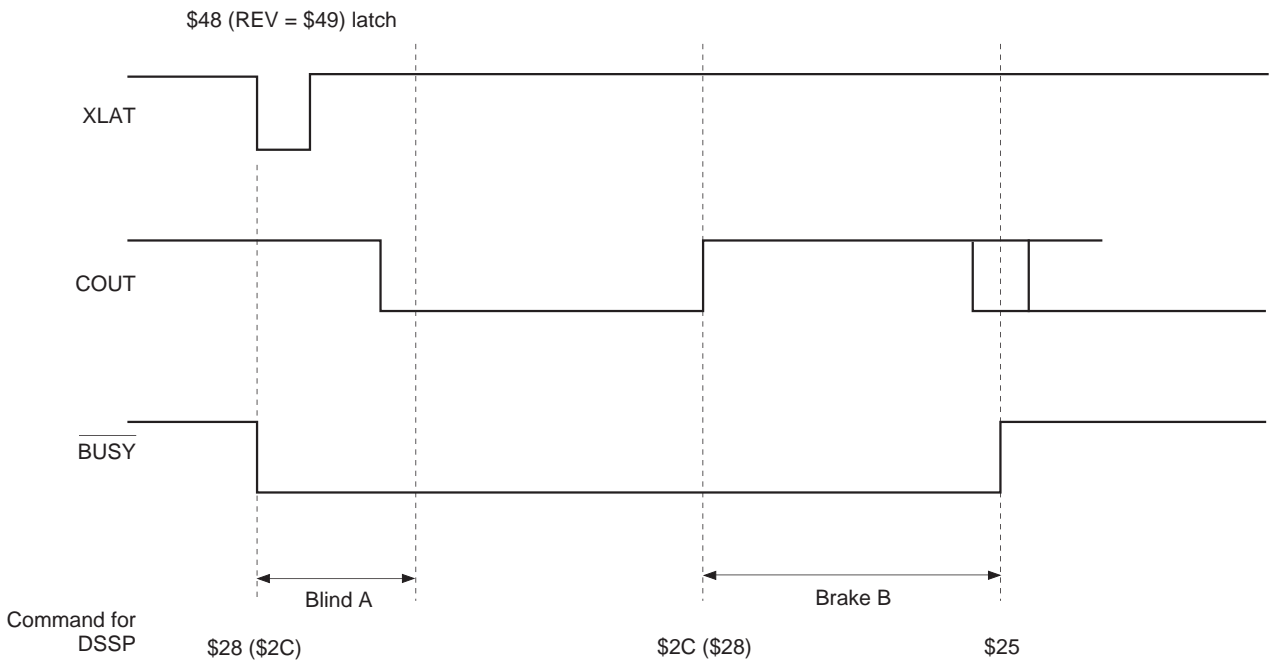

Fig. 4-7-(b). 1-Track Jump Timing Chart

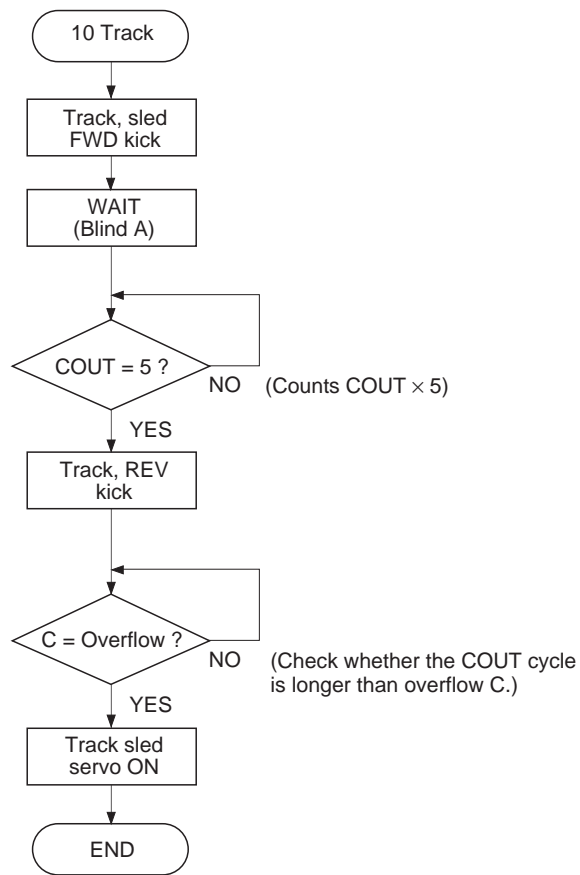

Fig. 4-8-(a). 10-Track Jump Flow Chart

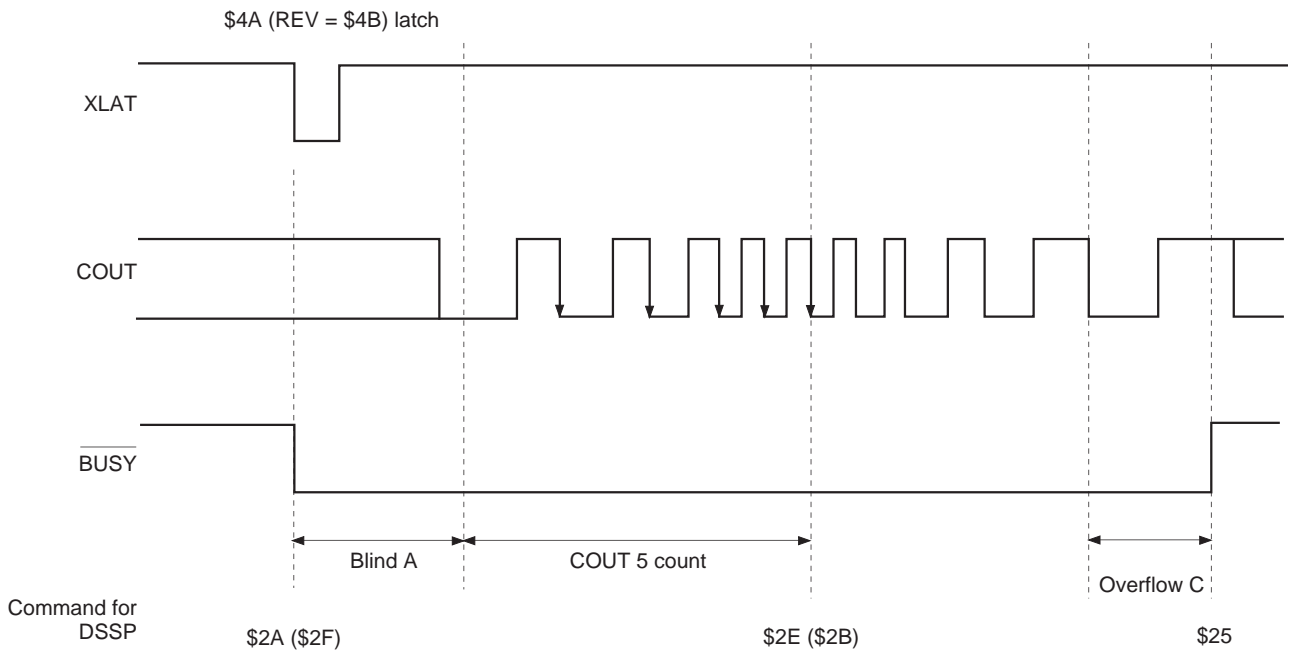

Fig. 4-8-(b). 10-Track Jump Timing Chart

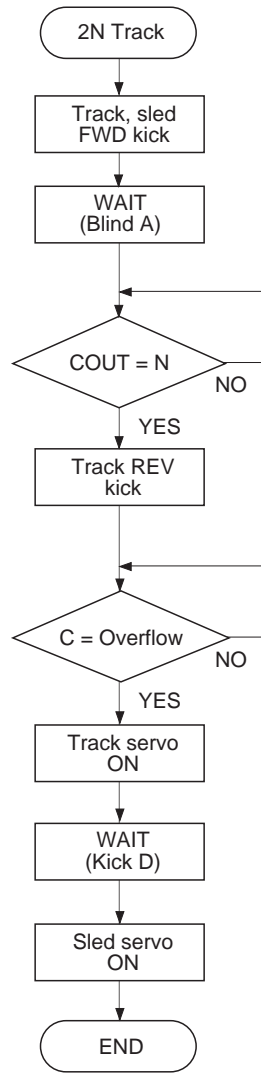

Fig. 4-9-(a). 2N-Track Jump Flow Chart

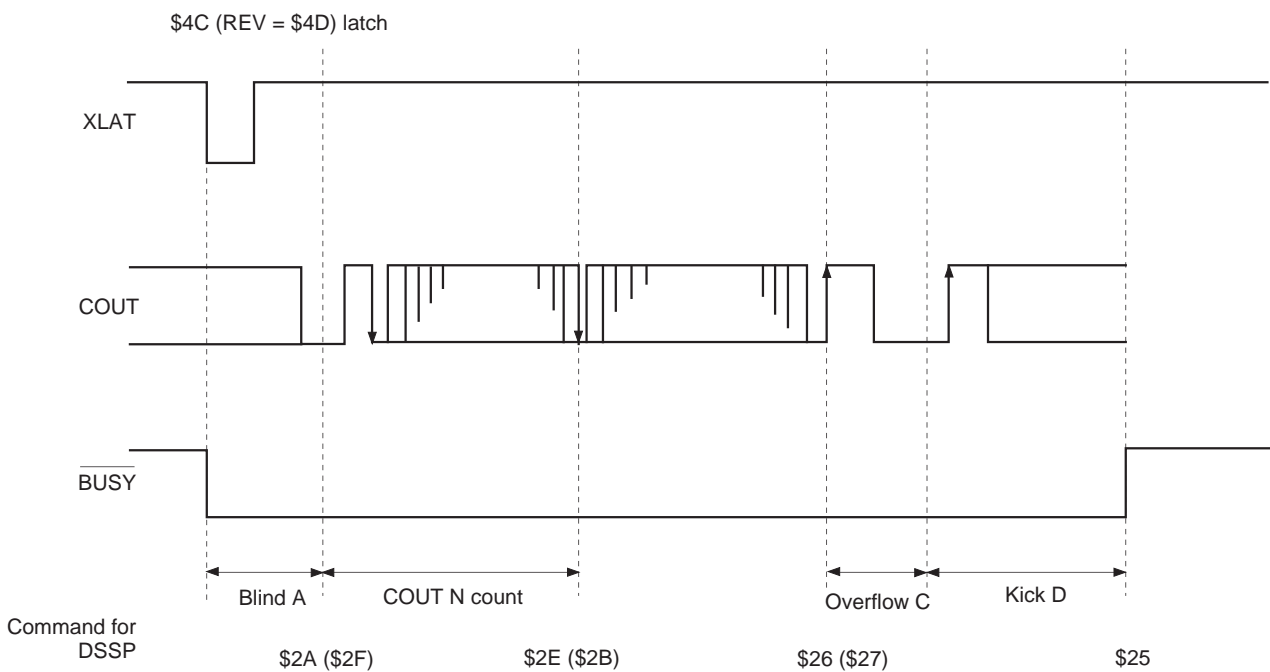

Fig. 4-9-(b). 2N-Track Jump Timing Chart

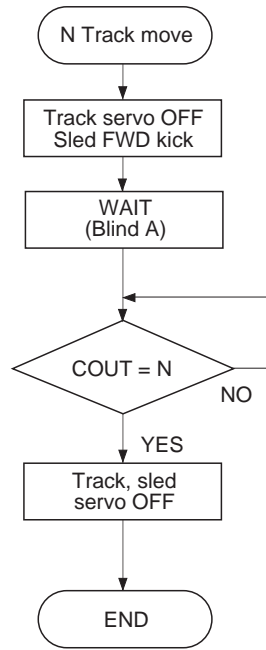

Fig. 4-10-(a). N-Track Move Flow Chart

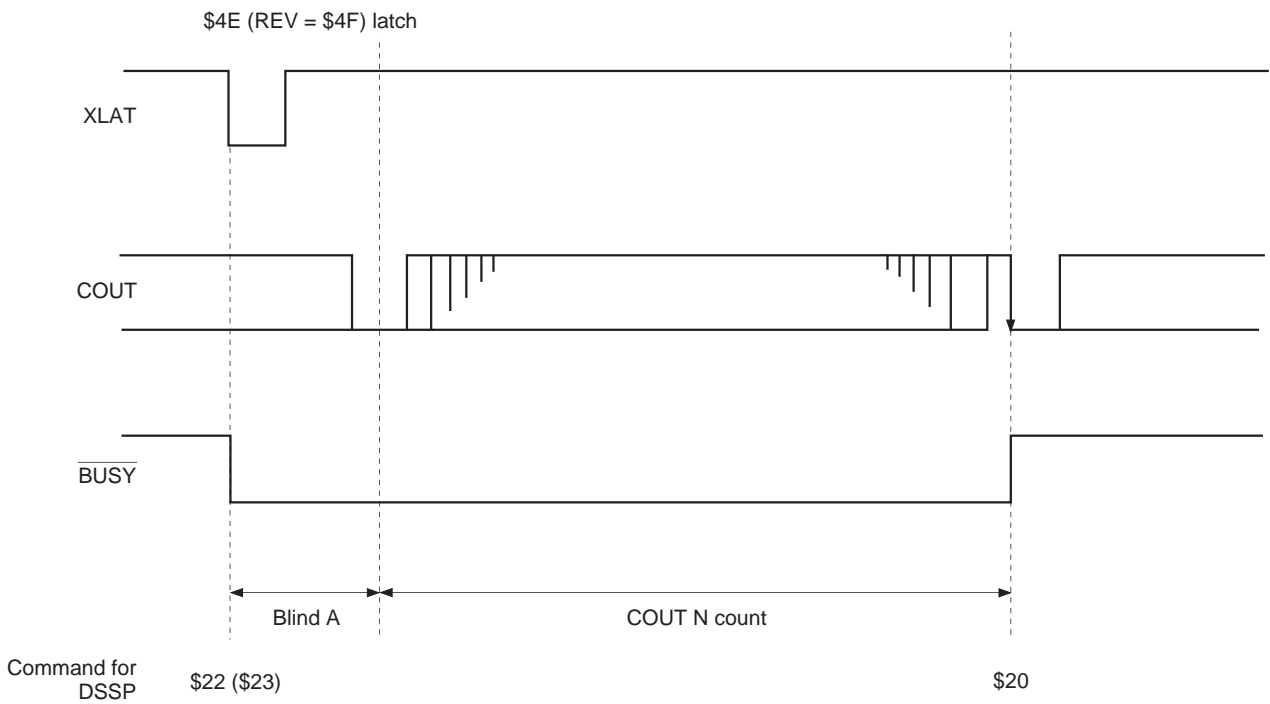
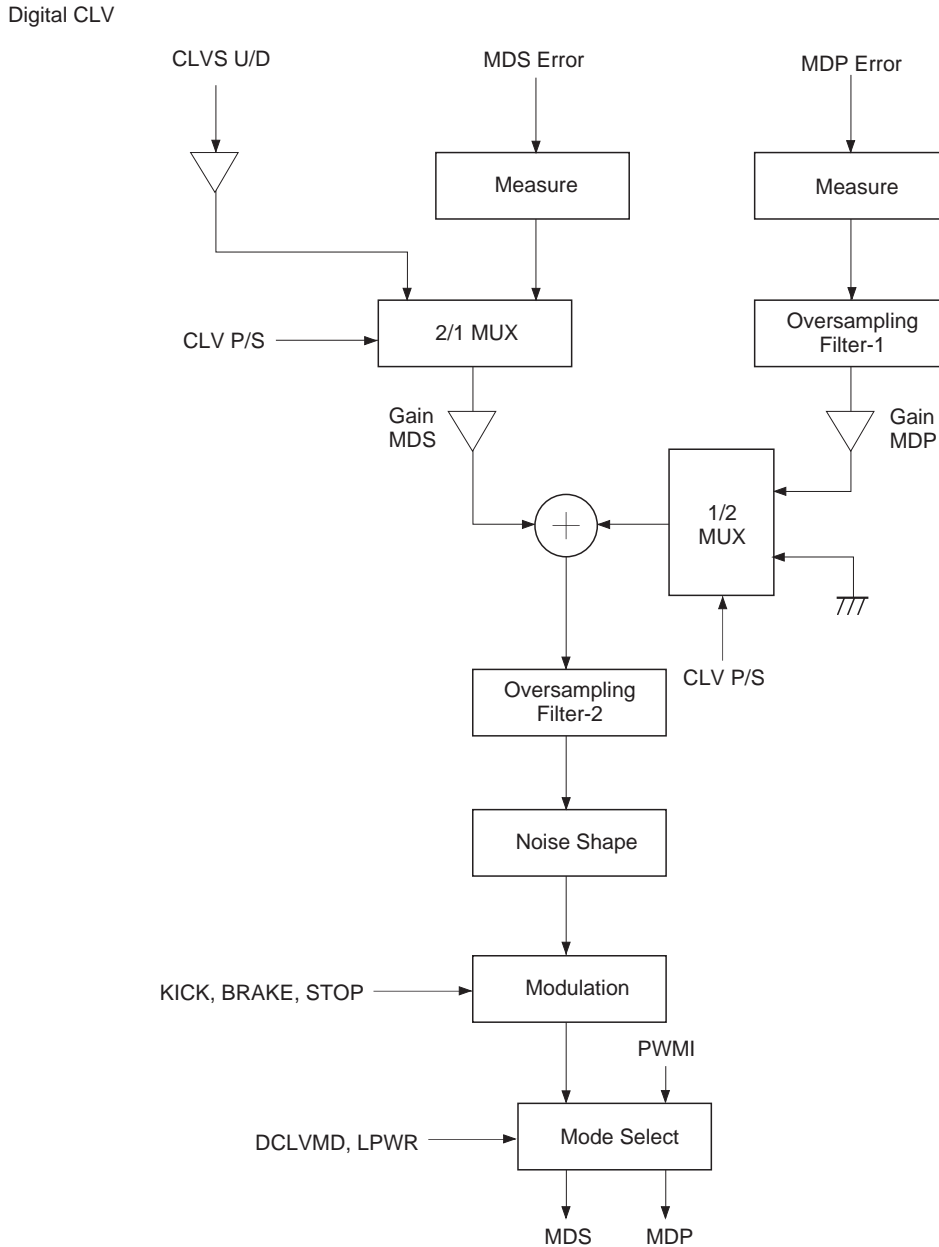

Fig. 4-10-(b). N-Track Move Timing Chart

§4-7. Digital CLV

Fig. 4-11 shows the block diagram. Digital CLV outputs MDS error and MDP error with PWM, with the sampling frequency increased up to 130Hz during normal-speed playback in CLVS, CLVP and other modes. In addition, the digital spindle servo gain is variable.



CLVS U/D : Up/down signal from CLVS servo
 MDS error : Frequency error for CLVP servo
 MDP error : Phase error for CLVP servo
 PWMI : Spindle drive signal from the microcomputer

Fig. 4-11. Block Diagram

§4-8. CD-DSP Block Playback Speed

In the CXD2588Q/R, the following playback modes can be selected through different combinations of the crystal, XTSL pin and the DSPB command of \$9X.

CD-DSP block playback speed

Crystal	XTSL	DSPB	CD-DSP block playback speed
768Fs	0	1	4× ^{*1}
768Fs	1	0	1×
768Fs	1	1	2×
384Fs	0	0	1×
384Fs	0	1	2×
384Fs	1	1	1× ^{*2}

Fs = 44.1kHz.

*1 In 4× speed playback, the timer value for the auto sequence is halved.

*2 Low power consumption mode. The CD-DSP processing speed is halved, allowing power consumption to be reduced.

§4-9. DAC Block Playback Speed

The operation speed for the DAC block is determined by the crystal and the MCSL command of \$9X regardless of the CD-DSP operating conditions noted above. This allows the playback modes for the DAC and CD-DSP blocks to be set independently.

1-bit DAC block playback speed

Crystal	MCSL	DAC block playback speed
768Fs	1	1×
768Fs	0	2×
384Fs	0	1×

Fs = 44.1kHz.

§4-10. DAC Block Input Timing

Timing Chart 4-12 shows the DAC block input timing chart.

In the CXD2588Q/R, the data can be transferred from the CD signal processor block to the DAC block via the outside of the LSI. This allows the data to be sent to the DAC block via the audio DSP, etc.

As for the data input to the DAC block without using the audio DSP, there are two methods: one is to connect directly EMPH, LRCK, BCK and PCMD with EMPHI, LRCKI, BCKI and PCMDI outside the LSI; and the other is to set OUTL0 of \$8X to 1. Note that the outputs of EMPH, LRCK, BCK and PCMD become low when OUTL0 of \$8X is set to 0.

§4-11. Description of DAC Block Functions

Zero data detection

When the condition where the lower 4 bits of the input data are DC and the remaining upper bits are all "0" or all "1" has continued about for 300ms, zero data is detected. Zero data detection is performed independently for the left and right channels.

Mute flag output

The LMUT and RMUT pins go active when any one of the following conditions is met.

The polarity can be selected with the ZDPL command of \$9X.

- When zero data is detected
- When a high signal is input to the SYSM pin
- When the SMUT command of \$AX is set

Attenuation operation

Assuming attenuation data X1, X2 and X3 ($X1 > X3 > X2$), the corresponding audio outputs are Y1, Y2 and Y3 ($Y1 > Y3 > Y2$). First, X1 is sent, followed by X2. If X2 is sent before X1 reaches Y1 (A in the figure), X1 continues approaching Y2. Next, if X3 is sent before X1 reaches Y2 (B or C in the figure), X1 then approaches Y3 from the value (B or C in the figure) at that point.

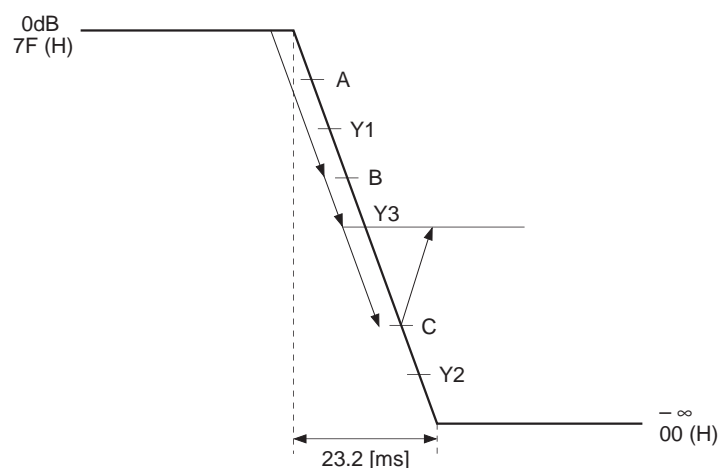

DAC block mute operation

Soft mute

Soft mute results and the input data is attenuated to zero when any one of the following conditions is met.

- When attenuation data of "000" (high) is set
- When the SMUT command of \$AX is set to 1
- When a high signal is input to the SYSM input pin

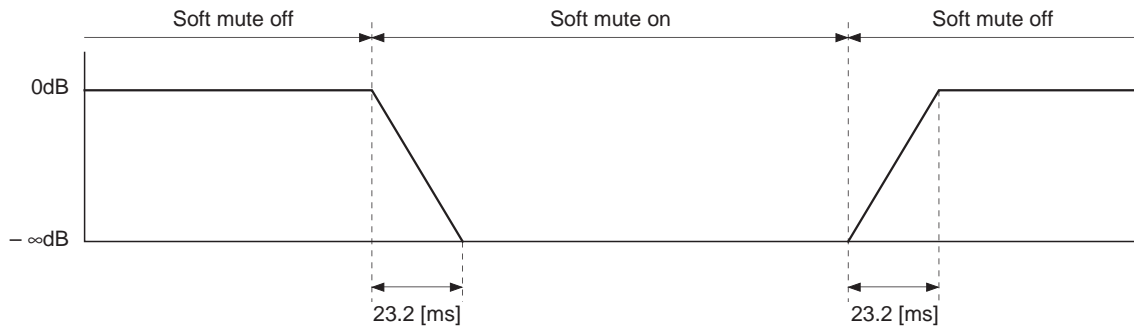

Forced mute

Forced mute results when the FMUT command of \$AX is set to 1.

Forced mute fixes the PWM output that is input to the LPF block to low.

* When setting FMUT, set OPSL2 to 1. (See the \$AX commands.)

Zero detection mute

Forced mute is applied when the ZMUT command of \$9X is set to 1 and the zero data is detected for the left and right channels.

(See "Zero data detection".)

When the ZMUT command of \$9X is set to 1, the forced mute is applied even if the mute flag output condition is met. When the zero detection mute is on, set the DCOF command of \$9X to 1.

Timing Chart 4-12

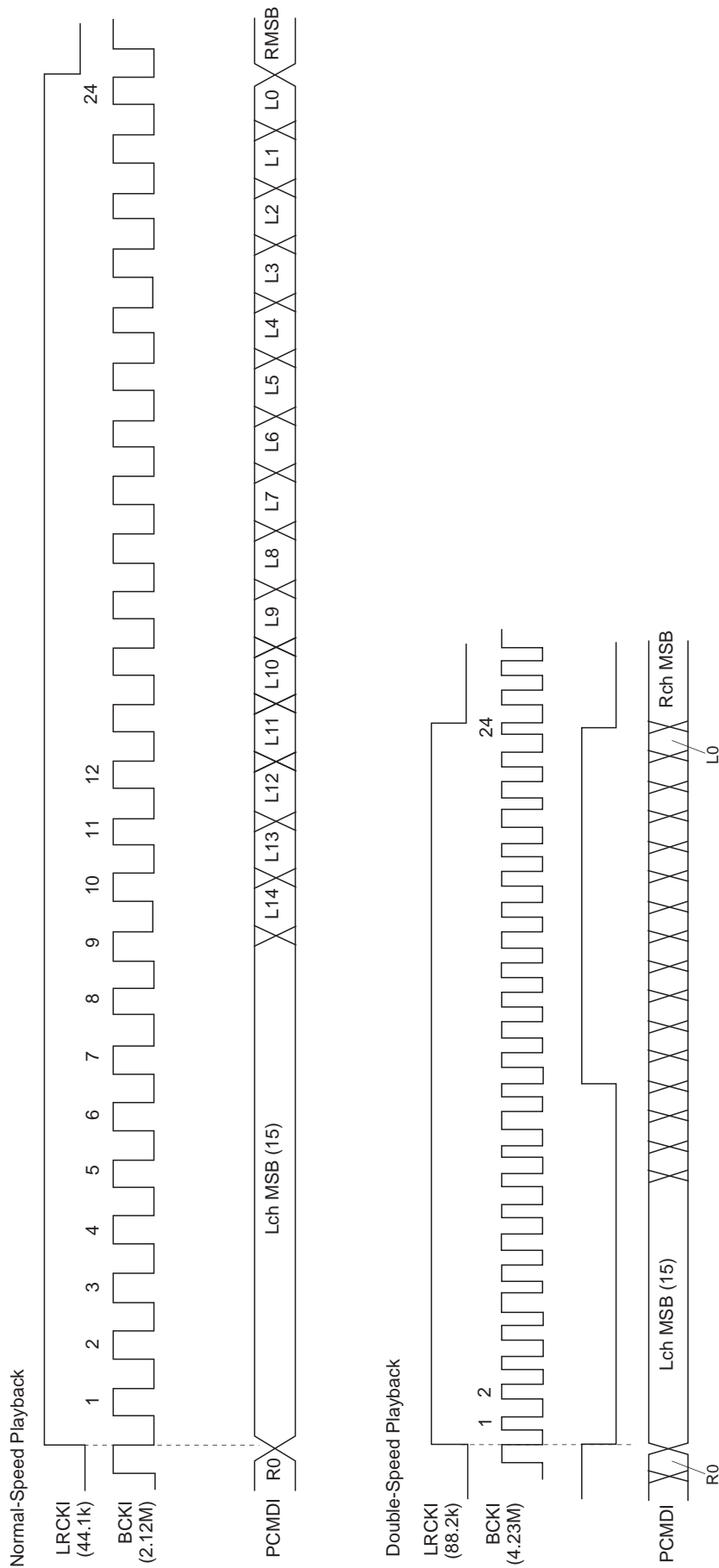

Input Timing DAC Block

LRCK Synchronization

Synchronization is performed at the first falling edge of the LRCK input during reset.

After that, synchronization is lost when the LRCK input frequency changes and resynchronization must be performed.

The LRCK input frequency changes when the master clock of the LSI is switched and the playback speed changes such as the following cases.

- When the XTSL pin switches between high and low
- When the DSPB command of \$9X setting changes
- When the MCSL command of \$9X setting changes

LRCK switching may also be performed if there are other ICs between the CD-DSP block and the DAC block. Resynchronization must be performed in this case as well.

For resynchronization, set the LRWO command of \$AX to 1, wait for one LRCK cycle or more, and then set LRWO to 0.

* When setting LRWO, set OPSL2 to 1. (See the \$AX commands.)

SYCOF

When LRCK, PCMD and BCK are connected directly with LRCKI, PCMDI and BCKI, respectively, playback can be performed easily in CAV-W mode by setting SYCOF of address 9 to 1.

Normally, the memory proof, etc. is used for playback in CAV-W mode.

In CAV-W mode, the LRCK output conforms not to the crystal but to the VCO. Therefore, synchronization is frequently lost.

Setting SYCOF of address 9 to 1 ignores that the LRCKI input synchronization is lost, facilitating playback. However, the playback is not perfect because pre-value hold or data skip occurs due to the wow flutter in the LRCKI input.

* Set SYCOF to 0 except when connecting LRCK, PCMD and BCK directly with LRCKI, PCMDI and BCKI, respectively, and performing playback in CAV-W mode.

Digital Bass Boost

Bass boost without external parts is possible using the built-in digital filter. The boost strength has two levels: Mid. and Max. BSBST and BBSL of address A are used for the setting.

See Graph 4-13 for the digital bass boost frequency response.

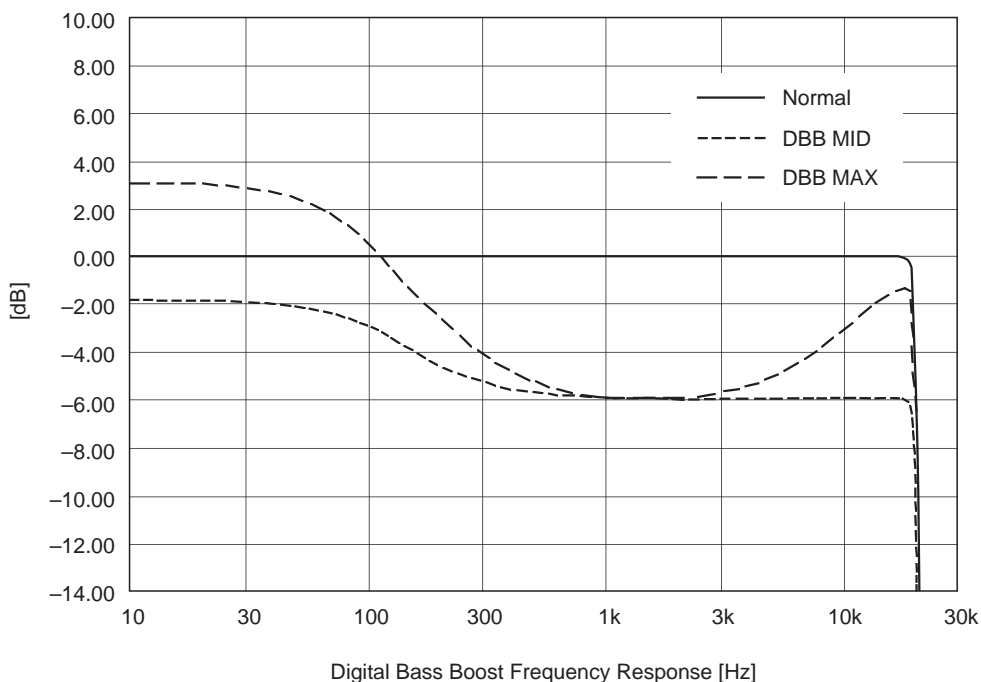

Graph 4-13.

§4-12. LPF Block

The CXD2588Q/R contains an initial-stage secondary active LPF with numerous resistors and capacitors and an operational amplifier with reference voltage.

The resistors and capacitors are attached externally, allowing the cut-off frequency f_c to be determined flexibly. The reference voltage (V_c) is $(AV_{DD} - AV_{SS}) \times 0.43$.

The LPF block application circuit is shown below.

In this circuit, the cut-off frequency is $f_c \approx 40\text{kHz}$.

The external capacitors' values when $f_c = 30\text{kHz}$ and 50kHz are noted below as a reference.

The resistors' values do not change at this time.

- When $f_c \approx 30\text{kHz}$:
C1 = 200pF, C2 = 910pF
- When $f_c \approx 50\text{kHz}$:
C1 = 120pF, C2 = 560pF

LPF Block Application Circuit

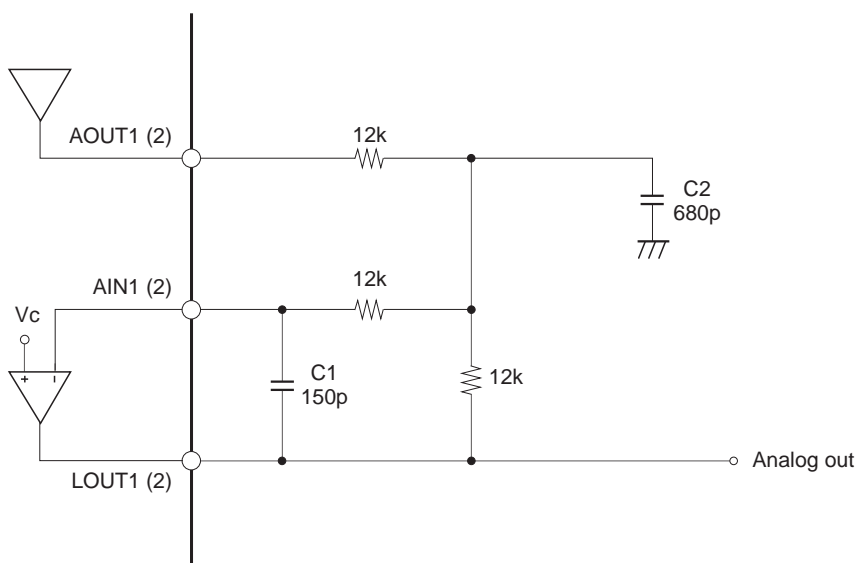

Fig. 4-14. LPF External Circuit

§4-13. Asymmetry Compensation

Fig. 4-15 shows the block diagram and circuit example.

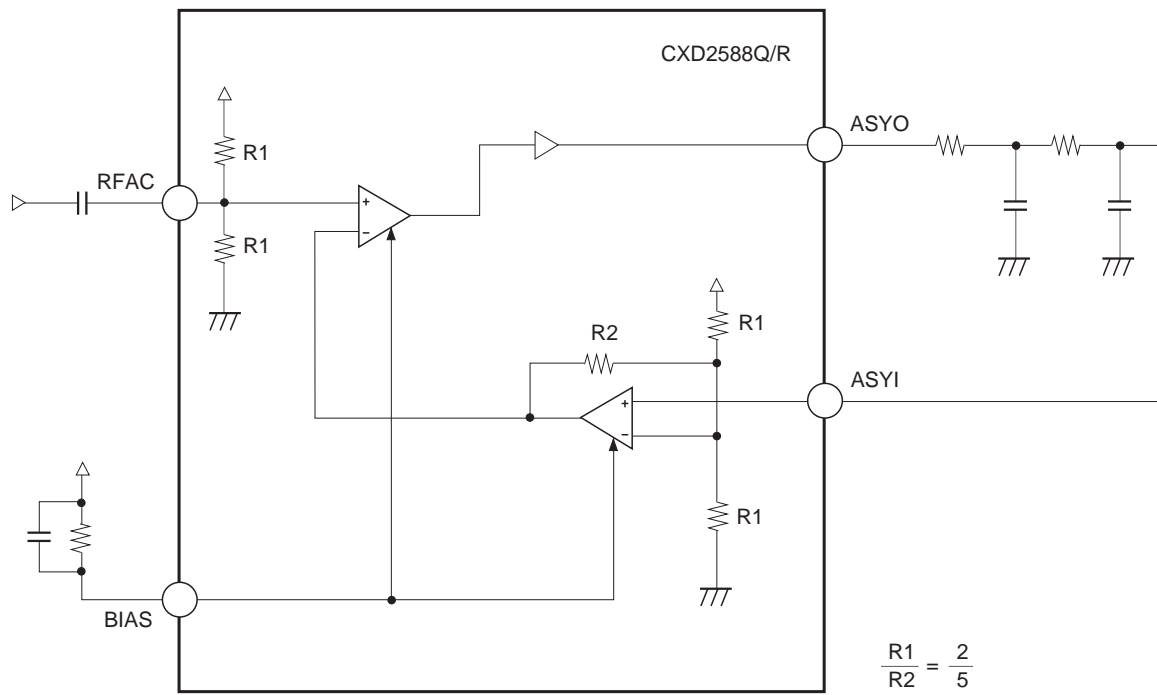

Fig. 4-15. Asymmetry Compensation Application Circuit

§4-14. CD TEXT Data Demodulation

- In order to demodulate the CD TEXT data, set the command \$8 Data 6 D3 TXON to 1. During TXON = 1, connect EXCK to low and do not use the data output from SBSO because the CD TEXT demodulation circuit uses EXCK and the SBSO pin exclusively.

It requires 26.7ms (max.) to demodulate the CD TEXT data correctly after TXON is set to 1.

- The CD TEXT data is output by switching the SQSO pin with the command. The CD TEXT data output is enabled by setting the command \$8 Data 6 D2 TXOUT to 1. To read data, the readout clock should be input to SQCK.
- The readable data are the CRC counting results for the each pack and the CD TEXT data (16 bytes) except for CRC data.
- When the CD TEXT data is read, the order of the MSB and LSB is inverted within each byte. As a result, although the sequence of the bytes is the same, the bits within the bytes are now ordered LSB first.
- Data which can be stored in the LSI is 1 packet (4 packs).

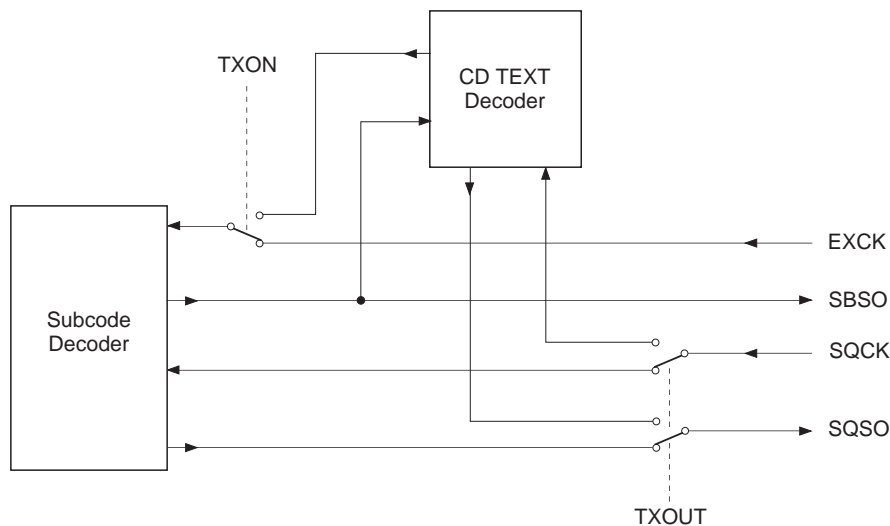

Fig. 4-16. Block Diagram of CD TEXT Demodulation Circuit

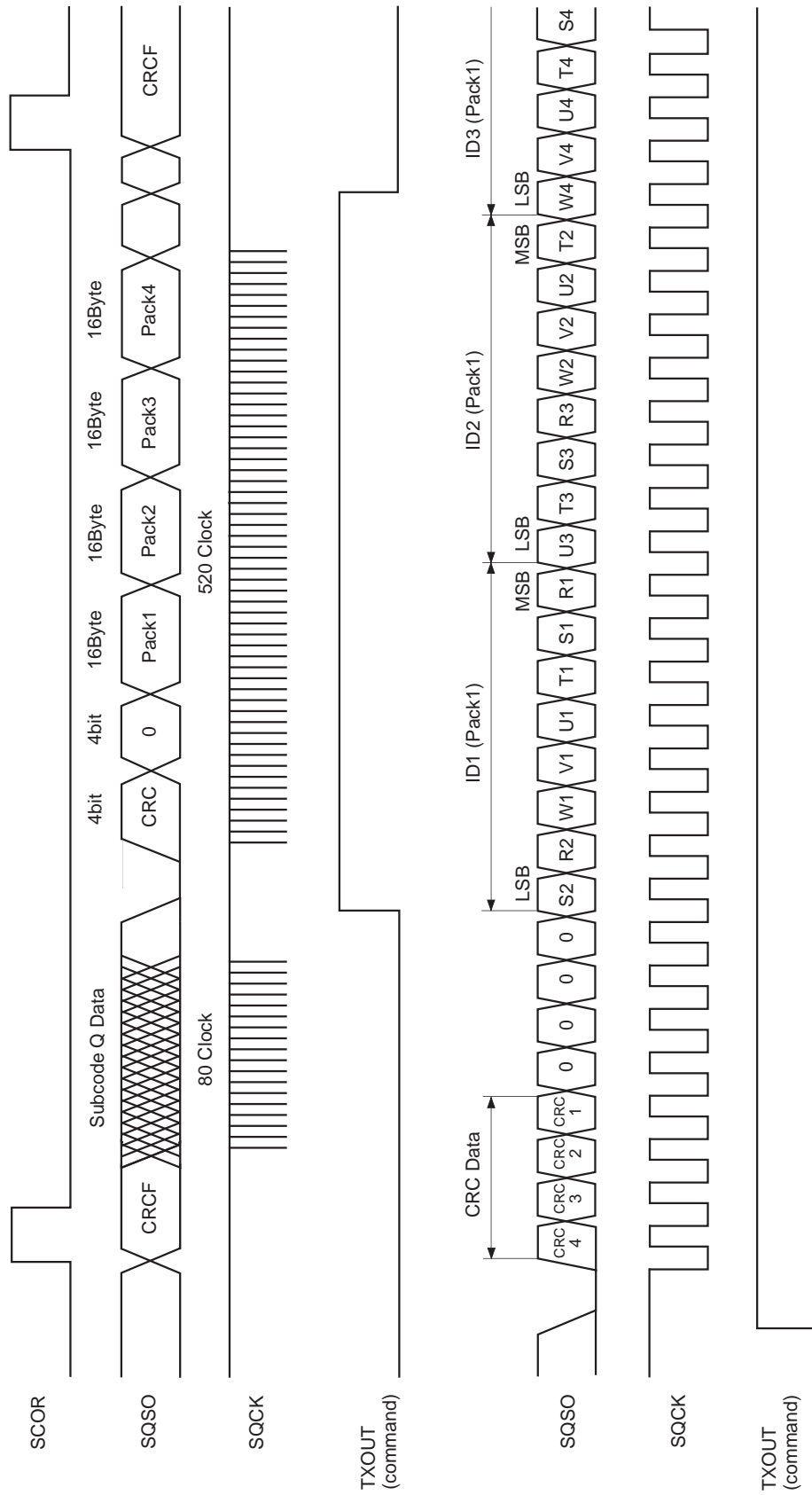

Fig. 4-17. CD TEXT Data Timing Chart

§5. Description of Servo Signal Processing System Functions and Commands

§5-1. General Description of Servo Signal Processing System (V_{DD} : Supply voltage)

Focus servo

Sampling rate:	88.2kHz (when MCK = 128Fs)
Input range:	0.3V _{DD} to 0.7V _{DD}
Output format:	7-bit PWM
Others:	Offset cancel Focus bias adjustment Focus search Gain-down function Defect countermeasure Auto gain control

Tracking servo

Sampling rate:	88.2kHz
Input range:	0.3V _{DD} to 0.7V _{DD}
Output format:	7-bit PWM
Others:	Offset cancel E:F balance adjustment Track jump Gain-up function Defect countermeasure Drive cancel Auto gain control Vibration countermeasure

Sled servo

Sampling rate:	345Hz (MCK = 128Fs)
Input range:	0.3V _{DD} to 0.7V _{DD}
Output format:	7-bit PWM
Others:	Sled move

FOK, MIRR, DFCT signals generation

RF signal sampling rate:	1.4MHz (MCK = 128Fs)
Input range:	0.43V _{DD} to V _{DD}
Others:	RF zero level automatic measurement

§5-2. Digital Servo Block Master Clock (MCK)

The internal master clock (MCK) is generated by dividing the frequency of the signal input to FSTI. The frequency division ratio is 1, 1/2 or 1/4.

Table 5-1 below shows the hypothetical case where the crystal clock generated from the digital signal processor block is 2/3 frequency-divided and input to the FSTI pin by externally connecting the FSTI pin and the FSTO pin. By setting \$8X command D1 OUTL1 to 1, FSTI and FSTO can be internally connected. (See \$8X commands.)

The XT4D and XT2D command settings can be made with D13 and D12 of \$3F, and XT1D with D1 of \$3E. (Default = 0)

The digital servo block is designed with an MCK frequency of 5.6448MHz.

Mode	Crystal	FSTO (FSTI)	XTSL	XT4D	XT2D	XT1D	Frequency division ratio	MCK
1	384Fs	256Fs	*	*	*	1	1	256Fs
2	384Fs	256Fs	*	*	1	0	1/2	128Fs
3	384Fs	256Fs	0	0	0	0	1/2	128Fs
4	768Fs	512Fs	*	*	*	1	1	512Fs
5	768Fs	512Fs	*	*	1	0	1/2	256Fs
6	768Fs	512Fs	*	1	0	0	1/4	128Fs
7	768Fs	512Fs	1	0	0	0	1/4	128Fs

Fs = 44.1kHz, *: Don't care

Table 5-1.

§5-3. AVRG (Average) Measurement and Compensation

The CXD2588Q/R has a circuit that measures the average of RFDC, VC, FE, and TE and a circuit that compensates them to control servo effectively.

AVRG measurement and compensation is necessary to initialize the CXD2588Q/R, and is able to cancel the offset.

The level applied to the VC, FE, RFDC and TE pins can be measured by setting D15 (VLCM), D13 (FLM), D11 (RFLM) and D4 (TCLM) of \$38 respectively to 1.

AVRG measurement consists of digitally measuring the level applied to each analog input pin by taking the average of 256 samples, and then loading these values into the AVRG register.

AVRG measurement requires approximately 2.9ms to 5.8ms after the command is received.

During AVRG measurement, if the upper 8 bits of the command register are 38 (Hex), the completion of AVRG measurement operation can be confirmed through the SENS pin. (See Timing Chart 5-2.)

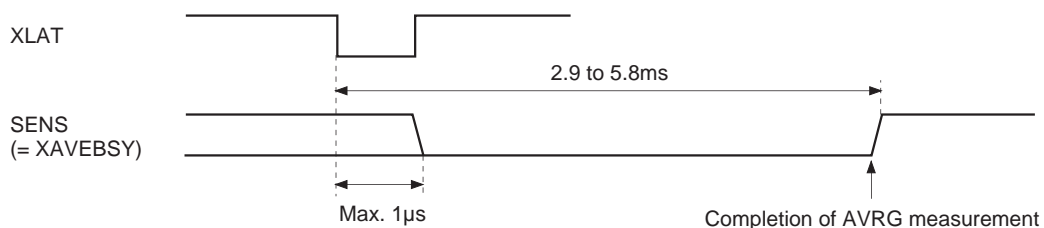

Timing Chart 5-2.

<Measurement>

• VC AVRG

The offset can be canceled by measuring the VC level which is the center voltage for the system and using that value to apply compensation to each input error signal.

• FE AVRG

The FE signal DC level is measured. In addition, compensation is applied to the FZC comparator level output from the SENS pin during FCS SEARCH (focus search) using these measurement results.

• TE AVRG

The TE signal DC level is measured.

• RF AVRG

The MIRR, DFCT and FOK signals are generated from the RF signal. Since the FOK signal is generated by comparing the RF signal at a certain level, it is necessary to establish a zero level which becomes the comparator level reference. Therefore, the RF signal is measured before playback, and is compensated to take this level as the zero level.

An example of sending AVRG measurement and compensation commands is shown below.

(Example) \$380800 (RF AVRG measurement on)

\$382000 (FE AVRG measurement on)

\$380010 (TE AVRG measurement on)

\$388000 (VC AVRG measurement on)

(Complete each AVRG measurement before starting the next.)

\$38140A (RFLC, FLC0, FLC1 and TLC1 commands on)

(The required compensation should be turned on together; see Fig. 5-3.)

An interval of 5.8ms (when MCK = 128Fs) or more must be maintained between each command, or the SENS pin must be monitored to confirm that the previous command has been completed before the next AVRG command is sent.

<Compensation>

See Fig. 5-3 for the contents of each compensation below.

• RFLC

The difference by which the RF signal exceeds the RF AVRG value is input to the RF In register.

(00 is input when the RF signal is lower than the RF AVRG value.)

• TCL0

The value obtained by subtracting the VC AVRG value from the TE signal is input to the TRK In register.

• TCL1

The value obtained by subtracting the TE AVRG value from the TE signal is input to the TRK In register.

• VCLC

The value obtained by subtracting the VC AVRG value from the FE signal is input to the FCS In register.

• FLC1

The value obtained by subtracting the FE AVRG value from the FE signal is input to the FCS In register.

• FLC0

The value obtained by subtracting the FE AVRG value from the FE signal is input to the FZC register.

§5-4. E:F Balance Adjustment Function

When the disc is rotated with the laser on, and with the FCS (focus) servo on via FCS Search (focus search), the traverse waveform appears in the TE signal due to disc eccentricity.

In this condition, the low-frequency component can be extracted from the TE signal using the built-in TRK hold filter by setting D5 (TBLM) of \$38 to 1.

The extracted low-frequency component is loaded into the TRVSC register as a digital value, and the TRVSC register value is established when TBLM returns to 0.

Next, setting D2 (TLC2) of \$38 to 1 compensates TE and SE values with the TRVSC register value (subtraction), resulting the E:F balance offset to be adjusted. (See Fig. 5-3.)

§5-5. FCS Bias (Focus Bias) Adjustment Function

The FBIAS register value can be added to the FCS servo filter input by setting D14 (FBON) of \$3A to 1. (See Fig. 5-3.)

When the FBIAS register value is set when D11 = 0 and D10 = 1 with \$34F, data can be written using the 9-bit value of D9 to D1 (D9: MSB).

In addition, the RF jitter can be monitored by setting the SOCT command of \$8 to 1. (See "DSP Block Timing Chart".)

The FBIAS register can be used as a counter by setting D13 (FBSS) of \$3A to 1. The FBIAS register functions as an up counter when D12 (FBUP) of \$3A = 1, and as a down counter when D12 (FBUP) of \$3A = 0.

The number of up and down steps can be changed by setting D11 and D10 (FBV1 and FBV0) of \$3A.

When using the FBIAS register as a counter, the counter stops if the FBIAS value and the value set beforehand in FBL9 to 1 of \$34 matches. Also, if the upper 8 bits of the command register are \$3A at this time, SENS becomes high and the counter stop can be monitored.

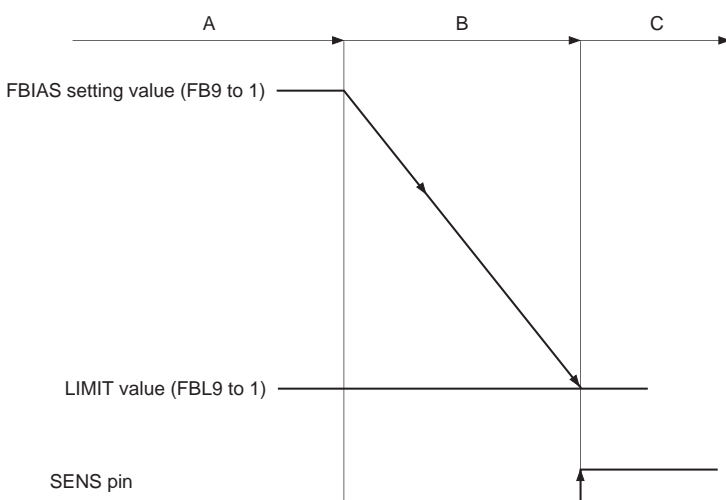

Here, assume the FBIAS setting value FB9 to 1 and the FBIAS LIMIT value FBL9 to 1 like status A. For example, if command registers FBUP = 0, FBV1 = 0, FBV0 = 0 and FBSS = 1 are set from this status, down count starts from status A and approaches the set LIMIT value. When the FBIAS value matches FBL9 to 1, the counter stops and the SENS pin goes to high. Note that the up/down counter counts at each sampling cycle of the focus servo filter. The number of steps by which the count value changes can be selected from 1, 2, 4 or 8 steps by FBV1 and FBV0. When converted to FE input, 1 step corresponds to $1/512 \times V_{DD} \times 0.4$.

A: Register mode
 B: Counter mode
 C: Counter mode (when stopped)

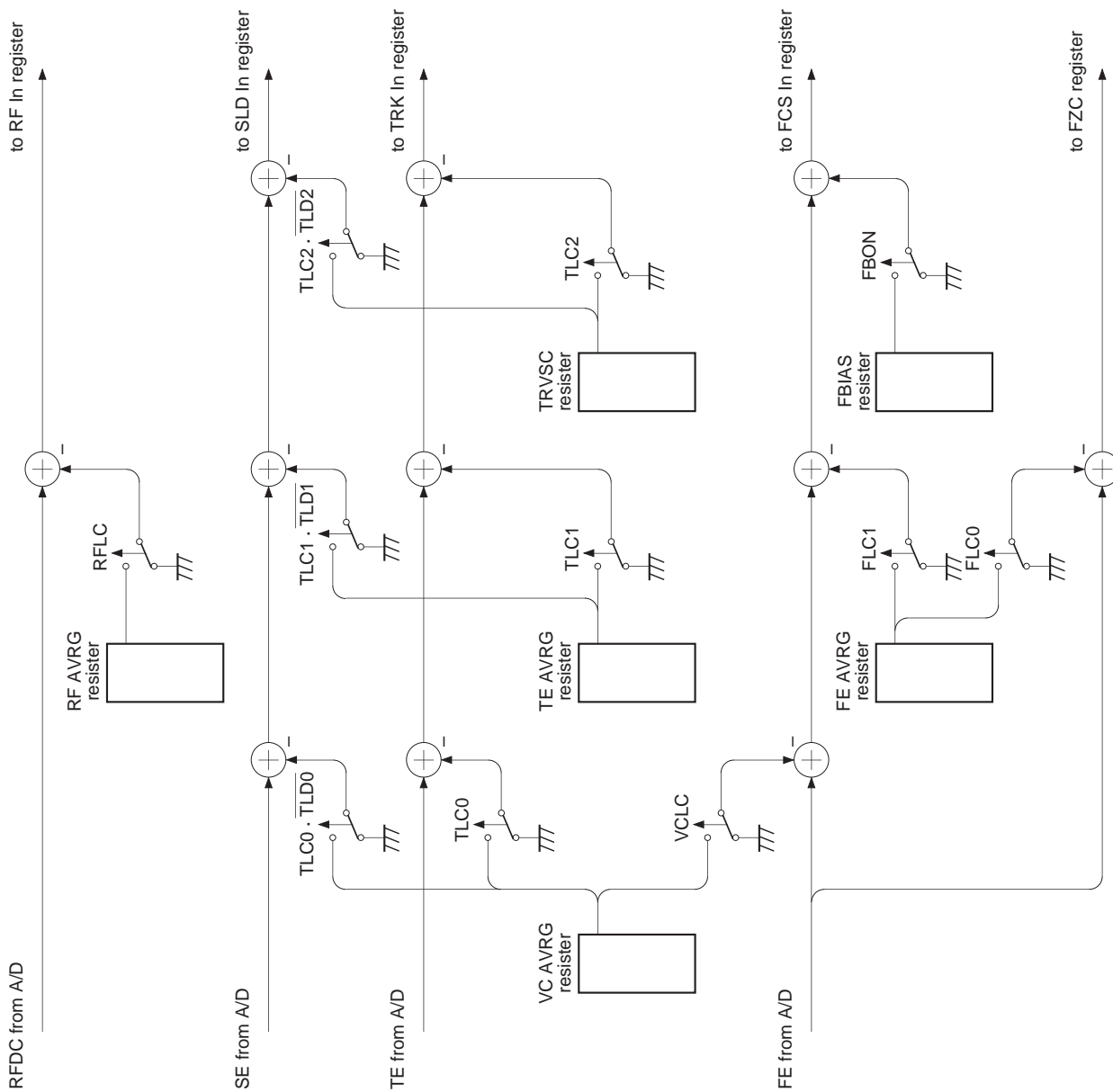

Fig. 5-3.

§5-6. AGCNTL (Automatic Gain Control) Function

The AGCNTL function automatically adjusts the filter internal gain in order to obtain the appropriate gain with the servo loop. AGCNTL not only copes with the sensitivity variation of the actuator and photo diode, etc., but also obtains the optimal gain for each disc.

The AGCNTL command is sent when each servo is turned on. During AGCNTL operation, if the upper 8 bits of the command register are 38 (Hex), the completion of AGCNTL operation can be confirmed through the SENS pin. (See Timing Chart 5-4 and "Description of SENS Signals".)

Setting D9 and D8 of \$38 to 1 set FCS (focus) and TRK (tracking) respectively to AGCNTL operation.

Note) During AGCNTL operation, each servo filter gain must be normal, and the anti-shock circuit (described hereafter) must be disabled.

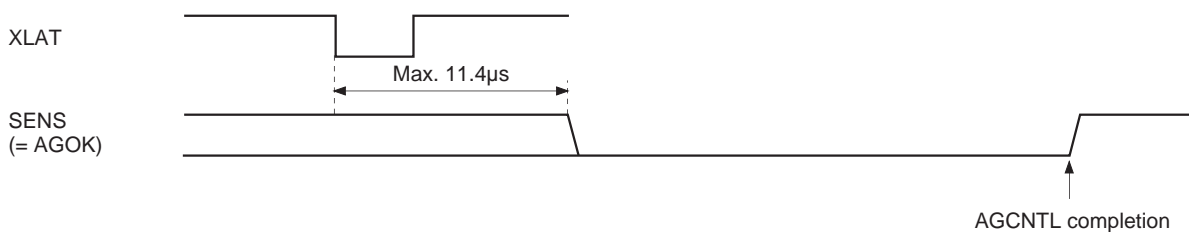

Timing Chart 5-4.

Coefficient K13 changes for AGF (focus AGCNTL) and coefficients K23 and K07 change for AGT (tracking AGCNTL) due to AGCNTL.

These coefficients change from 01 to 7F (Hex), and they must also be set within this range when written externally.

After AGCNTL operation has completed, these coefficient values can be confirmed by reading them out from the SENS pin with the serial readout function (described hereafter).

AGCNTL related settings

The following settings can be changed with \$35, \$36 and \$37.

FG6 to FG0; AGF convergence gain setting, effective setting range: 00 to 57 (Hex)

TG6 to TG0; AGT convergence gain setting, effective setting range: 00 to 57 (Hex)

AGS; Self-stop on/off

AGJ; Convergence completion judgment time

AGGF; Internally generated sine wave amplitude (AGF)

AGGT; Internally generated sine wave amplitude (AGT)

AGV1; AGCNTL sensitivity 1 (during rough adjustment)

AGV2; AGCNTL sensitivity 2 (during fine adjustment)

AGHS; Rough adjustment on/off

AGHT; Fine adjustment time

Note) Converging servo loop gain values can be changed with the FG6 to 0 and TG6 to 0 setting values. In addition, these setting values must be within the effective setting range. The default settings aim for 0 dB at 1kHz. However, since convergence values vary according to the characteristics of each constituent element of the servo loop, FG and TG values should be set as necessary.

AGCNTL and default operation have two stages.

In the first stage, rough adjustment is performed with high sensitivity for a certain period of time (select 256/128ms with AGHT, when MCK = 128Fs), and the AGCNTL coefficient approaches the appropriate value. The sensitivity at this time can be selected from two types with AGV1.

In the second stage, the AGCNTL coefficient is finely adjusted to approach more appropriate value with relatively low sensitivity. The sensitivity for the second stage can be selected from two types with AGV2. In the second stage of default operation, when the AGCNTL coefficient reaches the appropriate value and stops changing, the CXD2588Q/R confirms that the AGCNTL coefficient has not changed for a certain period of time (select 63/31ms with AGHJ, when MCK = 128Fs), and then completes AGCNTL operation. (Self-stop mode) This self-stop mode can be canceled by setting AGS to 0.

In addition, the first stage is omitted for AGCNTL operation when AGHS is set to 0.

An example of AGCNTL coefficient transitions during AGCNTL in various settings are shown in Fig. 5-5.

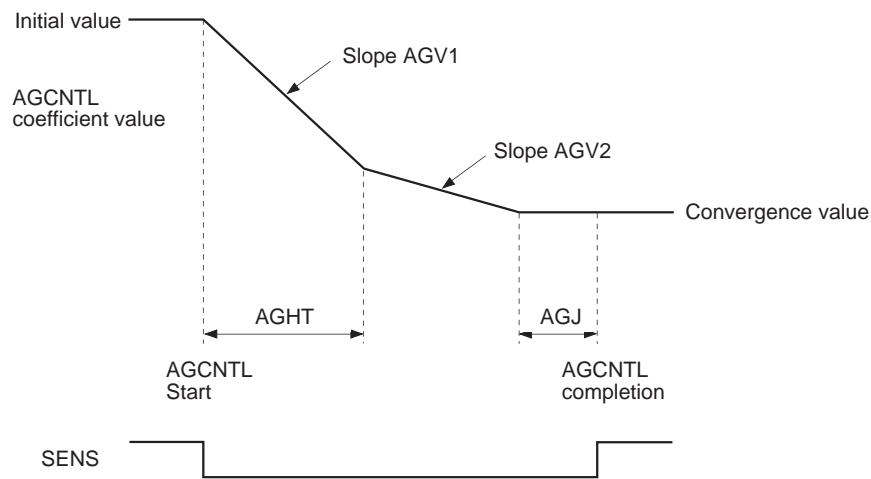

Fig. 5-5.

Note) Fig. 5-5 shows the example where the AGCNTL coefficient value converges to the smaller value from the initial value.

§5-7. FCS Servo and FCS Search (Focus Search)

The FCS servo is controlled by the 8-bit serial command \$0X. (See Table 5-6.)

Register name	Command	D23 to D20	D19 to D16	
0	FOCUS CONTROL	0 0 0 0	1 0 * *	FOCUS SERVO ON (FOCUS GAIN NORMAL)
			1 1 * *	FOCUS SERVO ON (FOCUS GAIN DOWN)
			0 * 0 *	FOCUS SERVO OFF, 0V OUT
			0 * 1 *	FOCUS SERVO OFF, FOCUS SEARCH VOLTAGE OUT
			0 * 1 0	FOCUS SEARCH VOLTAGE DOWN
			0 * 1 1	FOCUS SEARCH VOLTAGE UP

*: Don't care

Table 5-6.

FCS Search

FCS search is required in the course of turning on the FCS servo.

Fig. 5-7 shows the signals for sending commands \$00 → \$02 → \$03 and performing only FCS search operation.

Fig. 5-8 shows the signals for sending \$08 (FCS on) after that.

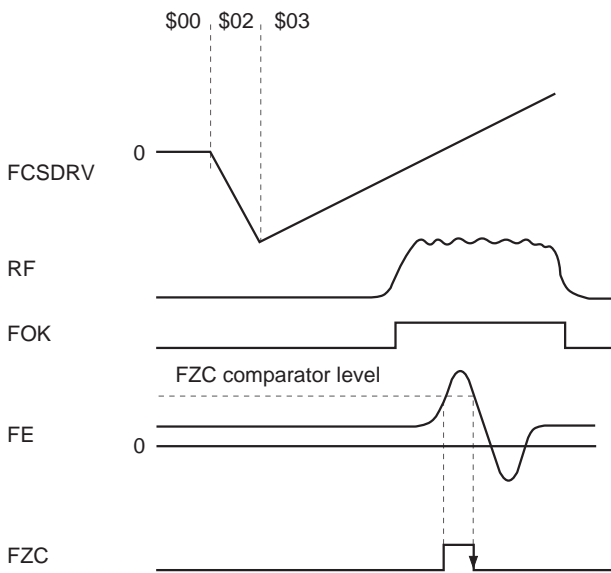

Fig. 5-7.

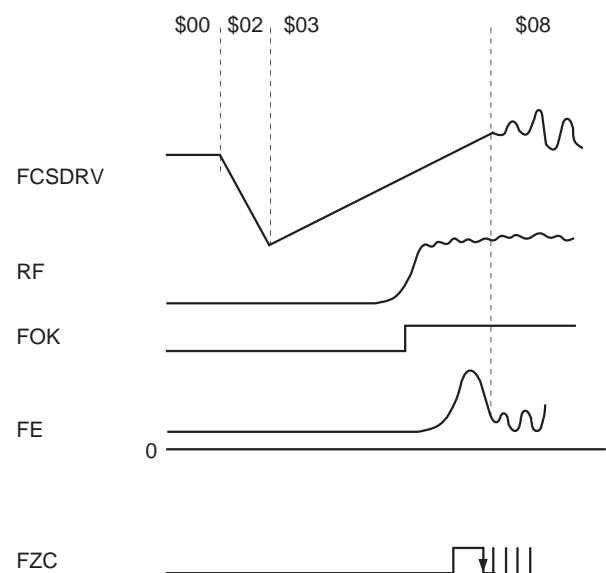

Fig. 5-8.

§5-8. TRK (Tracking) and SLD (Sled) Servo Control

The TRK and SLD servos are controlled by the 8-bit command \$2X. (See Table 5-9.)

When the upper 4 bits of the serial data are 2 (Hex), TZC is output to the SENS pin.

Register name	Command	D23 to D20	D19 to D16	
2	TRACKING MODE	0 0 1 0	0 0 * *	TRACKING SERVO OFF
			0 1 * *	TRACKING SERVO ON
			1 0 * *	FORWARD TRACK JUMP
			1 1 * *	REVERSE TRACK JUMP
			* * 0 0	SLED SERVO OFF
			* * 0 1	SLED SERVO ON
			* * 1 0	FORWARD SLED MOVE
			* * 1 1	REVERSE SLED MOVE

*: Don't care

Table 5-9.

TRK Servo

The TRK JUMP (track jump) level can be set with 6 bits (D13 to D8) of \$36.

In addition, when the TRK servo is on and D17 of \$1 is set to 1, the TRK servo filter switches to gain-up mode. The filter also switches to gain-up mode when the LOCK signal goes low or when vibration is detected with the anti-shock circuit (described hereafter) enabled.

CXD2588Q/R has 2 types of filters in TRK gain-up mode which can be selected by setting D16 of \$1. (See Table 5-17.)

SLD Servo

The SLD MOV (sled move) output, composed of a basic value from 6 bits (D13 to D8) of \$37, is determined by multiplying this value by 1×, 2×, 3× or 4× magnification set using D17 and D16 when D18 = D19 = 0 is set with \$3. (See Table 5-10.)

SLD MOV must be performed continuously for 50μs or more. In addition, if the LOCK input signal goes low when the SLD servo is on, the SLD servo turns off.

Note) When the LOCK signal is low, the TRK servo switches to gain-up mode and the SLD servo is turned off by the default. These operations are disabled by setting D6 (LKSW) of \$38 to 1.

Register name	Command	D23 to D20	D19 to D16	
3	SELECT	0 0 1 1	0 0 0 0	SLED KICK LEVEL (basic value × ±1)
			0 0 0 1	SLED KICK LEVEL (basic value × ±2)
			0 0 1 0	SLED KICK LEVEL (basic value × ±3)
			0 0 1 1	SLED KICK LEVEL (basic value × ±4)

Table 5-10.

§5-9. MIRR and DFCT Signal Generation

The RF signal obtained from the RFDC pin is sampled at approximately 1.4MHz (when MCK = 128Fs) and loaded. The MIRR and DFCT signals are generated from this RF signal.

MIRR Signal Generation

The loaded RF signal is applied to peak hold and bottom hold circuits.

An envelope is generated from the waveforms generated in these circuits, and the MIRR comparator level is generated from the average of this envelope waveform.

The MIRR signal is generated by comparing the waveform generated by subtracting the bottom hold value from the peak hold value with this MIRR comparator level. (See Fig. 5-11.)

The bottom hold speed and mirror sensitivity can be selected from 4 values using D7 and 6, and D5 and 4, respectively, of \$3C.

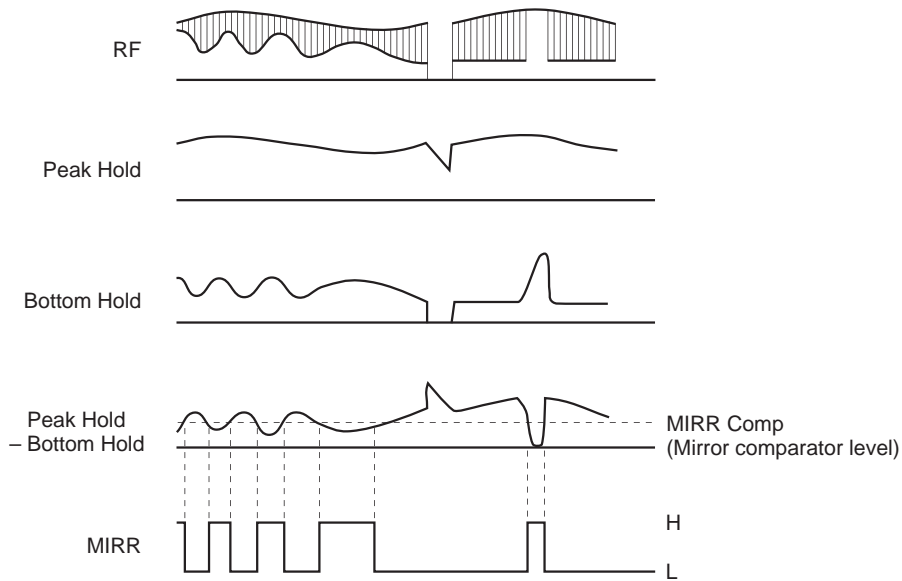

Fig. 5-11.

DFCT Signal Generation

The loaded RF signal is input to two peak hold circuits with different time constants, and the DFCT signal is generated by comparing the difference between these two peak hold waveforms with the DFCT comparator level. (See Fig. 5-12.)

The DFCT comparator level can be selected from four values using D13 and D12 of \$3B.

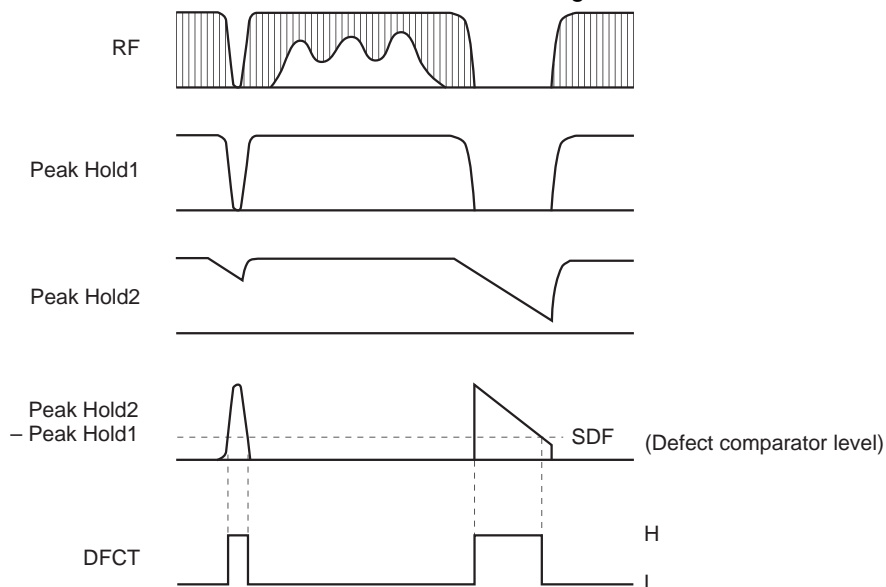

Fig. 5-12.

§5-10. DFCT Countermeasure Circuit

The DFCT countermeasure circuit maintains the directionality of the servo so that the servo does not become easily dislocated due to scratches or defects on discs.

Specifically, these operations are achieved by detecting scratch and defect with the DFCT signal generation circuit, and when DFCT goes high, applying the low-frequency component of the error signal before DFCT went high to the FCS and TRK servo filter inputs. (See Fig. 5-13.)

In addition, these operations are activated by the default. They can be disabled by setting D7 (DFSW) of \$38 to 1.

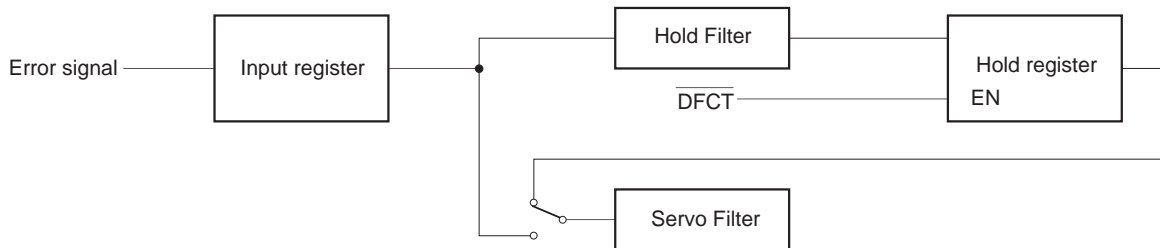

Fig. 5-13.

§5-11. Anti-Shock Circuit

When vibrations occurs in the CD player, this circuit forces the TRK filter to switch to gain-up mode so that the servo does not become easily dislocated. This circuit is for systems which require vibration countermeasures. Concretely, vibrations are detected using an internal anti-shock filter and comparator circuit, and the gain is increased. (See Fig. 5-14.)

The comparator level is fixed to 1/16 of the maximum comparator input amplitude. However, the comparator level is practically variable by adjusting the value of the anti-shock filter output coefficient K35.

This function can be turned on and off by D19 of \$1 when the brake circuit (described hereafter) is off. (See Table 5-17.)

This circuit can also support an external vibration detection circuit, and can set the TRK servo filter to gain-up mode by inputting high level to the ATSK pin.

When the upper 4 bits of the command register are 1 (Hex), vibration detection can be monitored from the SENS pin. It also can be monitored from the ATSK pin by setting the ASOT command of \$3F.

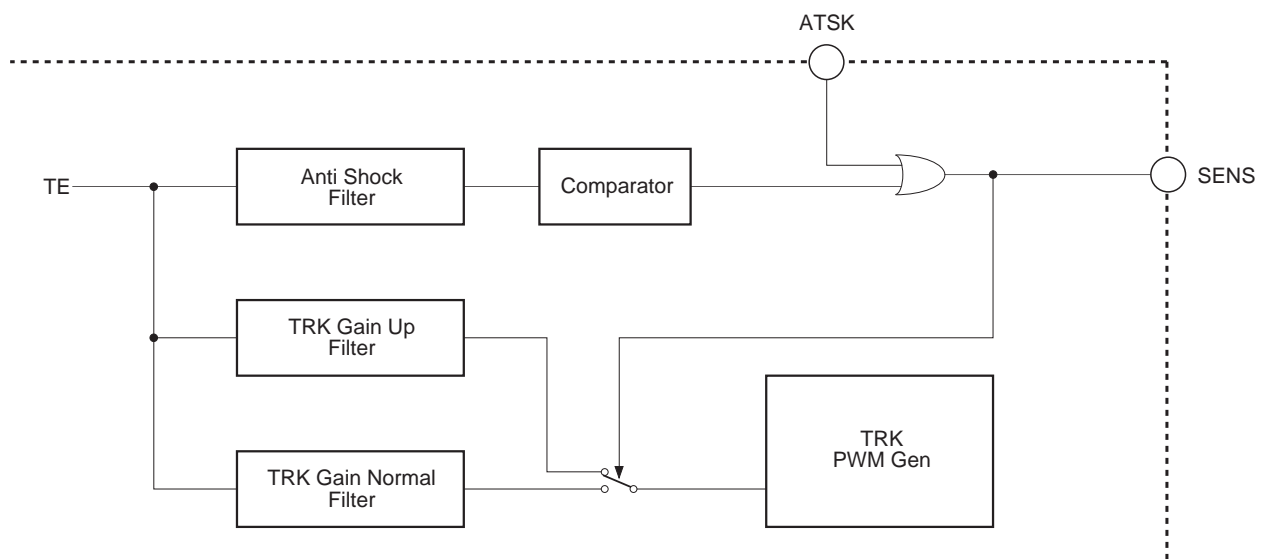

Fig. 5-14.

§5-12. Brake Circuit

Immediately after a long distance track jump it tends to be hard for the actuator to settle and for the servo to turn on.

The brake circuit prevents these phenomenon.

The brake circuit is to use tracking drive as a brake by cutting unnecessary portions of it utilizing the 180° offset in the RF envelope and tracking error phase relationship which occurs when the actuator traverses the track in the radial direction from the inner track to the outer track and vice versa. (See Figs. 5-15 and 5-16.)

Concretely, this operation is achieved by masking the tracking drive using the TRKCNCL signal generated by loading the MIRR signal at the edge of the TZC (Tracking Zero Cross) signal.

The brake circuit can be turned on and off by D18 of \$1. (See Fig. 5-17.)

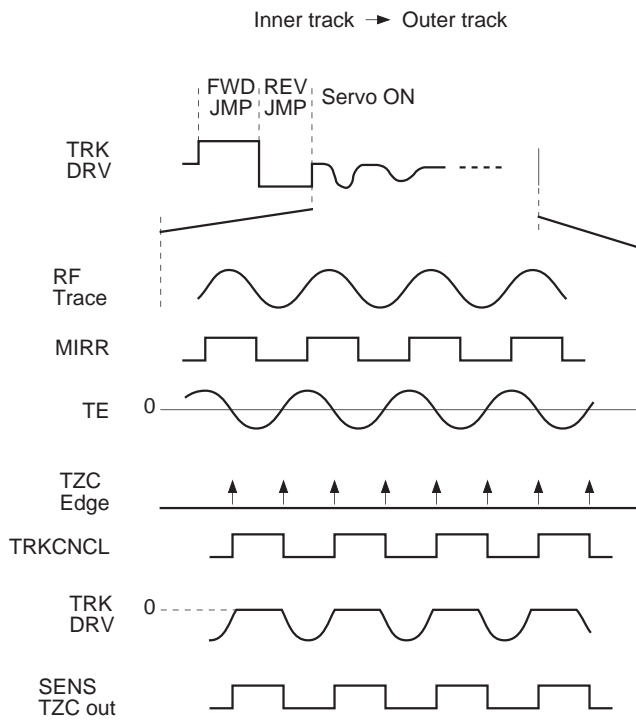

Fig. 5-15.

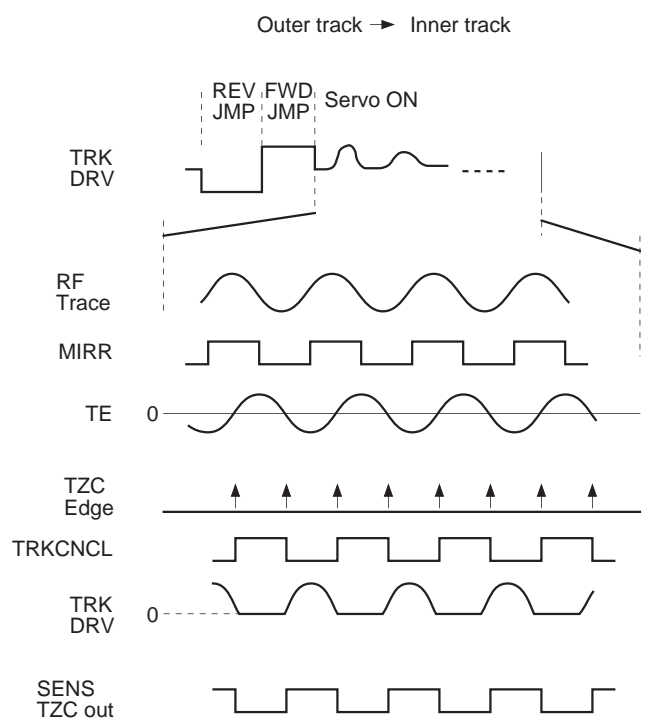

Fig. 5-16.

Register name	Command	D23 to D20	D19 to D16	
1	TRACKING CONTROL	0 0 0 1	1 0 * *	ANTI SHOCK ON
			0 * * *	ANTI SHOCK OFF
			* 1 * *	BRAKE ON
			* 0 * *	BRAKE OFF
			* * 0 *	TRACKING GAIN NORMAL
			* * 1 *	TRACKING GAIN UP
			* * * 1	TRACKING GAIN UP FILTER SELECT 1
			* * * 0	TRACKING GAIN UP FILTER SELECT 2

*: Don't care

Fig. 5-17.

§5-13. COUT Signal

The COUT signal is output to count the number of tracks during traverse, etc. It is basically generated by loading the MIRR signal at both edges of the TZC signal. And the used TZC signal can be selected among three different phases for each COUT signal application.

- HPTZC: For 1-track jumps
Fast phase COUT signal generation with a fast phase TZC signal. (The TZC phase is advanced by a cut-off 1kHz digital HPF; when MCK = 128Fs.)
- STZC: For COUT signal generation when MIRR is externally input and for applications other than COUT generation.
This is generated from sampling TE at 700kHz. (when MCK = 128Fs)
- DTZC: For high-speed traverse
Reliable COUT signal generation with a delayed phase STZC signal.

Since it takes some time to generate the MIRR signal, it is necessary to delay the TZC signal in accordance with the MIRR signal delay during high-speed traverse.

The COUT signal output method is switched with D15 and 14 of \$3C.

- When D15 = 1 : STZC
- When D15 = 0 and D14 = 0 : HPTZC
- When D15 = 0 and D14 = 1 : DTZC

When the DTZC is selected, the delay can be selected from two values with D14 of \$36.

§5-14. Serial Readout Circuit

The following measurement and adjustment results can be readout from the SENS pin by inputting the readout clock to the SCLK pin by \$39. (See Fig. 5-18, Table 5-19 and "Description of SENS Signals".)

Specified commands

- \$390C: VC AVRG measurement result
- \$3908: FE AVRG measurement result
- \$3904: TE AVRG measurement result
- \$391F: RF AVRG measurement result
- \$3953: FCS AGCNTL coefficient result
- \$3963: TRK AGCNTL coefficient result
- \$391C: TRVSC adjustment result
- \$391D: FBIAS register value

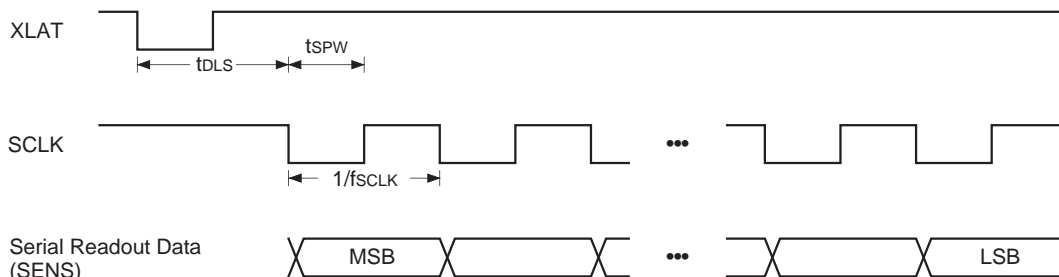

Fig. 5-18.

Item	Symbol	Min.	Typ.	Max.	Unit
SCLK frequency	f _{SCLK}			16	MHz
SCLK pulse width	t _{SPW}	31.3			ns
Delay time	t _{DLS}	15			μs

Table 5-19.

During readout, the upper 8 bits of the command register must be 39 (Hex).

§5-15. Writing to the Coefficient RAM

The coefficient RAM can be rewritten by \$34. All coefficients have default values in the built-in ROM, and transfer from the ROM to the RAM is completed approximately 40µs (when MCK = 128Fs) after the XRST pin rises. (The coefficient RAM cannot be rewritten during this period.)

After that, the characteristics of each built-in filter can be finely adjusted by rewriting the data for each address of the coefficient RAM.

The coefficient rewrite command is comprised of 24 bits, with D14 to D8 of \$34 as the address (D15 = 0) and D7 to D0 as data. Coefficient rewriting is completed 11.3µs (when MCK = 128Fs) after the command is received. When rewriting multiple coefficients, be sure to wait 11.3µs (when MCK = 128Fs) before sending the next rewrite command.

§5-16. PWM Output

FCS, TRK and SLD outputs are output as PWM waveforms.

In particular, FCS and TRK permit accurate drive by using a double oversampling noise shaper.

Timing Chart 5-20 and Fig. 5-21 show examples of output waveforms and drive circuits.

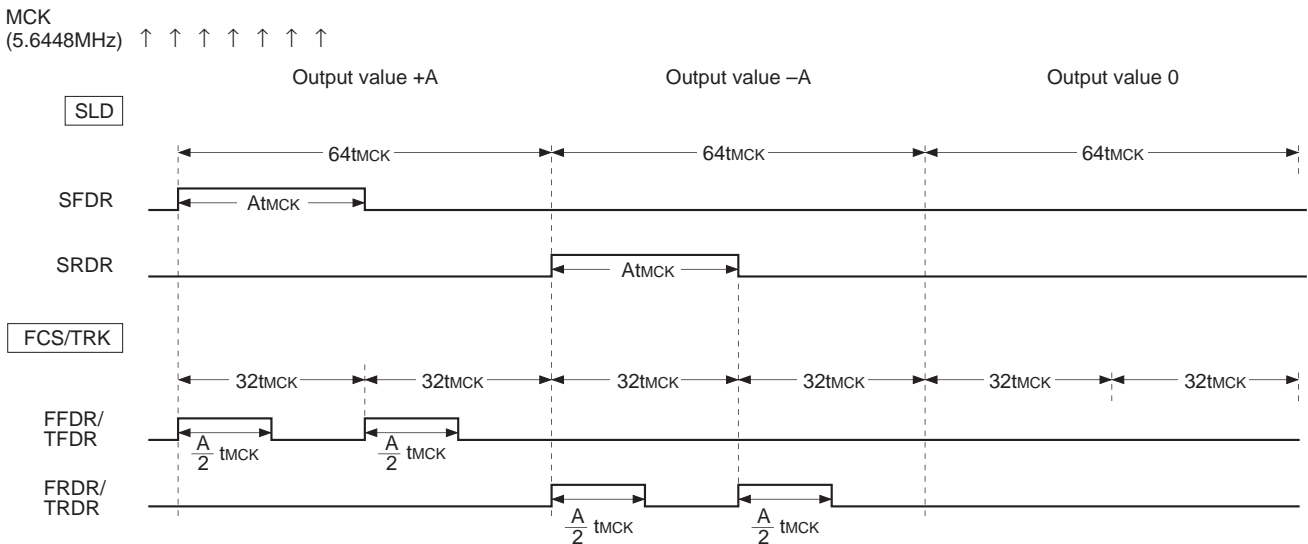

$$t_{MCK} = \frac{1}{5.6448MHz} \approx 180ns$$

Timing Chart 5-20.

Example of Driver Circuit

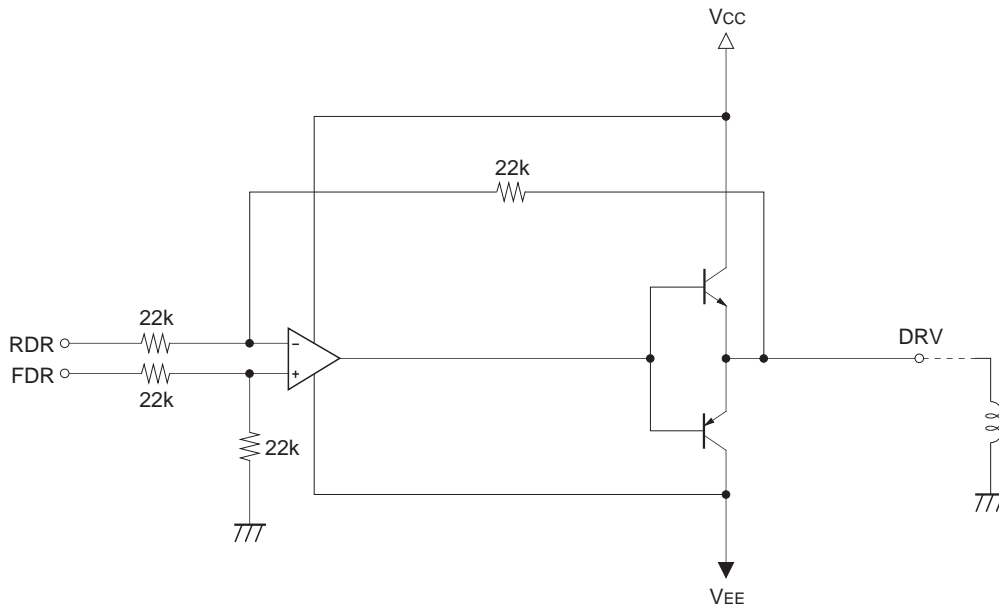

Fig. 5-21. Driver Circuit

§5-17. Servo Status Changes Produced by the LOCK Signal

When the LOCK signal becomes low, the TRK servo switches to the gain-up mode and the SLD servo turns off in order to prevent SLD free-running.

Setting D6 (LKSW) of \$38 to 1 deactivates this function.

In other words, neither the TRK servo nor the SLD servo change even when the LOCK signal becomes low.

This enables microcomputer control.

§5-18. Description of Commands and Data Sets

The following description contains portions which convert internal voltages into the values when they are output externally and describe them as input conversion or output conversion.

Input conversion converts these voltages into the voltages entering input pins before A/D conversion.

Output conversion converts PWM output values into analog voltage values.

\$34

D15	D14	D13	D12	D11	D10	D9	D8	D7	D6	D5	D4	D3	D2	D1	D0
0	KA6	KA5	KA4	KA3	KA2	KA1	KA0	KD7	KD6	KD5	KD4	KD3	KD2	KD1	KD0

When D15 = 0

KA6 to KA0: Coefficient address

KD7 to KD0: Coefficient data

D15	D14	D13	D12	D11	D10	D9	D8	D7	D6	D5	D4	D3	D2	D1	D0
1	1	1	1	1	0	FBL9	FBL8	FBL7	FBL6	FBL5	FBL4	FBL3	FBL2	FBL1	—

When D15 = D14 = D13 = D12 = D11 = 1 (\$34F)

D10 = 0

FBIAS LIMIT register write

FBL9 to FBL1: Data; data compared with FB9 to 1, FBL9 = MSB.

When using the FBIAS register in counter mode, counter operation stops when the value of FB9 to 1 matches with FBL9 to 1.

D15	D14	D13	D12	D11	D10	D9	D8	D7	D6	D5	D4	D3	D2	D1	D0
1	1	1	1	0	1	FB9	FB8	FB7	FB6	FB5	FB4	FB3	FB2	FB1	—

When D15 = D14 = D13 = D12 = 1 (\$34F)

D11 = 0, D10 = 1

FBIAS register write

FB9 to FB1: Data; FB9 is MSB two's complement data.

For FE input conversion, FB9 to FB1 = 01111111 corresponds to $255/256 \times V_{DD}/5$ and FB9 to FB1 = 10000000 to $-256/256 \times V_{DD}/5$ respectively. (V_{DD} : supply voltage)

D15	D14	D13	D12	D11	D10	D9	D8	D7	D6	D5	D4	D3	D2	D1	D0
1	1	1	1	0	0	TV9	TV8	TV7	TV6	TV5	TV4	TV3	TV2	TV1	TV0

When D15 = D14 = D13 = D12 = 1 (\$34F)

D11 = 0, D10 = 0

TRVSC register write

TV9 to TV0: Data; TV9 is MSB two's complement data.

For TE input conversion, TV9 to TV0 = 0011111111 corresponds to $255/256 \times V_{DD}/5$ and TV9 to TV0 = 1100000000 to $-256/256 \times V_{DD}/5$ respectively. (V_{DD} : supply voltage)

- Note)**
- When the TRVSC register is readout, the data length is 9 bits. At this time, data corresponding to each bit TV8 to TV0 during external write are readout.
 - When reading out internally measured values and then writing these values externally, set TV9 the same as TV8.

\$35 (preset: \$35 58 2D)

D15	D14	D13	D12	D11	D10	D9	D8	D7	D6	D5	D4	D3	D2	D1	D0
FT1	FT0	FS5	FS4	FS3	FS2	FS1	FS0	FTZ	FG6	FG5	FG4	FG3	FG2	FG1	FG0

FT1, FT0, FTZ: Focus search-up speed
 Default value: 010 ($0.673 \times V_{DD}$ V/s)
 Focus drive output conversion

	FT1	FT0	FTZ	Focus search speed [V/s]
	0	0	0	$1.35 \times V_{DD}$
*	0	1	0	$0.673 \times V_{DD}$
	1	0	0	$0.449 \times V_{DD}$
	1	1	0	$0.336 \times V_{DD}$
	0	0	1	$1.79 \times V_{DD}$
	0	1	1	$1.08 \times V_{DD}$
	1	0	1	$0.897 \times V_{DD}$
	1	1	1	$0.769 \times V_{DD}$

*: preset, V_{DD} : PWM driver supply voltage

FS5 to FS0: Focus search limit voltage
 Default value: 011000 ($\pm 24/64 \times V_{DD}$, V_{DD} : PWM driver supply voltage)
 Focus drive output conversion

FG6 to FG0: AGF convergence gain setting value
 Default value: 0101101

\$36 (preset: \$36 0E 2E)

D15	D14	D13	D12	D11	D10	D9	D8	D7	D6	D5	D4	D3	D2	D1	D0
TDZC	DTZC	TJ5	TJ4	TJ3	TJ2	TJ1	TJ0	SFJP	TG6	TG5	TG4	TG3	TG2	TG1	TG0

TDZC: Selects the TZC signal for generating the TRKCNCL signal during brake circuit operation.
 TDZC = 0: the edge of the HPTZC or STZC signal, whichever has the faster phase, is used.
 TDZC = 1: the edge of the HPTZC or STZC signal or the tracking drive signal zero-cross, whichever has the faster phase, is used. (See §5-12.)

DTZC: DTZC delay ($8.5/4.25\mu\text{s}$, when $MCK = 128Fs$)
 Default value: 0 ($4.25\mu\text{s}$)

TJ5 to TJ0: Track jump voltage
 Default value: 001110 ($\approx \pm 14/64 \times V_{DD}$, V_{DD} : PWM driver supply voltage)
 Tracking drive output conversion

SFJP: Surf jump mode on/off
 The tracking PWM output is made by adding the tracking filter output and TJReg (TJ5 to 0), by setting D7 to 1 (on)

TG6 to TG0: AGT convergence gain setting value
 Default value: 0101110

\$37 (preset: \$37 50 BA)

D15	D14	D13	D12	D11	D10	D9	D8	D7	D6	D5	D4	D3	D2	D1	D0
FZSH	FZSL	SM5	SM4	SM3	SM2	SM1	SM0	AGS	AGJ	AGGF	AGGT	AGV1	AGV2	AGHS	AGHT

FZSH, FZSL: FZC (Focus Zero Cross) slice level

Default value: 01 ($1/8 \times V_{DD} \times 0.4$, V_{DD} : supply voltage); FE input conversion

	FZSH	FZSL	Slice level
	0	0	$1/4 \times V_{DD} \times 0.4$
*	0	1	$1/8 \times V_{DD} \times 0.4$
	1	0	$1/16 \times V_{DD} \times 0.4$
	1	1	$1/32 \times V_{DD} \times 0.4$

*: preset

SM5 to SM0: Sled move voltage

Default value: 010000 ($\approx \pm 16/64 \times V_{DD}$, V_{DD} : PWM driver supply voltage)

Sled drive output conversion

AGS: AGCNTL self-stop on/off

Default value: 1 (on)

AGJ: AGCNTL convergence completion judgment time during low sensitivity adjustment (31/63ms, when MCK = 128Fs)

Default value: 0 (63ms)

AGGF: Focus AGCNTL internally generated sine wave amplitude (small/large)

Default value: 1 (large)

AGGT: Tracking AGCNTL internally generated sine wave amplitude (small/large)

Default value: 1 (large)

		FE/TE input conversion
AGGF	0 (small)	$1/32 \times V_{DD} \times 0.4$
	1 (large)*	$1/16 \times V_{DD} \times 0.4$
AGGT	0 (small)	$1/16 \times V_{DD} \times 0.4$
	1 (large)*	$1/8 \times V_{DD} \times 0.4$

*: preset

AGV1: AGCNTL convergence sensitivity during high sensitivity adjustment; high/low

Default value: 1 (high)

AGV2: AGCNTL convergence sensitivity during low sensitivity adjustment; high/low

Default value: 0 (low)

AGHS: AGCNTL high sensitivity adjustment on/off

Default value: 1 (on)

AGHT: AGCNTL high sensitivity adjustment time (128/256ms, when MCK = 128Fs)

Default value: 0 (256ms)

\$38 (preset: \$38 00 00)

D15	D14	D13	D12	D11	D10	D9	D8	D7	D6	D5	D4	D3	D2	D1	D0
VCLM	VCLC	FLM	FLC0	RFLM	RFLC	AGF	AGT	DFSW	LKSW	TBLM	TCLM	FLC1	TLC2	TLC1	TLC0

- ◎ VCLM: VC level measurement (on/off)
- VCLC: VC level compensation for FCS In register (on/off)
- ◎ FLM: Focus zero level measurement (on/off)
- FLC0: Focus zero level compensation for FZC register (on/off)
- ◎ RFLM: RF zero level measurement (on/off)
- RFLC: RF zero level compensation (on/off)
- AGF: Focus auto gain adjustment (on/off)
- AGT: Tracking auto gain adjustment (on/off)
- DFSW: Defect disable switch (on/off)
- Setting this switch to 1 (on) disables the defect countermeasure circuit.
- LKSW: Lock switch (on/off)
- Setting this switch to 1 (on) disables the sled free-running prevention circuit.
- TBLM: Traverse center measurement (on/off)
- ◎ TCLM: Tracking zero level measurement (on/off)
- FLC1: Focus zero level compensation for FCS In register (on/off)
- TLC2: Traverse center compensation (on/off)
- TLC1: Tracking zero level compensation (on/off)
- TLC0: VC level compensation for TRK/SLD In register (on/off)

Note) Commands marked with ◎ are accepted every 2.9ms. (when MCK = 128Fs)
All commands are on when set to 1.

\$39

D15	D14	D13	D12	D11	D10	D9	D8
DAC	SD6	SD5	SD4	SD3	SD2	SD1	SD0

DAC: Serial data readout DAC mode (on/off)

SD6 to SD0: Serial readout data select

SD6	SD5	Readout data			Readout data length		
1		Coefficient RAM data for address = SD5 to SD0			8 bits		
0	1	Data RAM data for address = SD4 to SD0			16 bits		
0	0	SD4	SD3 to SD0				
		1	1 1 1 1	RF AVRG register	8 bits	\$399F	
			1 1 1 0	RFDC input signal	8 bits	\$399E	
			1 1 0 1	FBIAS register	9 bits	\$399D	
			1 1 0 0	TRVSC register	9 bits	\$399C	
			0 0 1 1	RFDC envelope (bottom)	8 bits	\$3993	
			0 0 1 0	RFDC envelope (peak)	8 bits	\$3992	
			0 0 0 1	RFDC envelope (peak) – (bottom)	8 bits	\$3991	
			0	0	1 1 * *	VC AVRG register	9 bits
		1 0 * *			FE AVRG register	9 bits	\$3988
		0 1 * *			TE AVRG register	9 bits	\$3984
		0 0 1 1			FE input signal	8 bits	\$3983
		0 0 1 0			TE input signal	8 bits	\$3982
		0 0 0 1			SE input signal	8 bits	\$3981
		0 0 0 0	VC input signal	8 bits	\$3980		

Note) Coefficients K40 to K4F cannot be readout.

*: Don't care

See the description for SRO1 of \$3F concerning readout methods for the above data.

\$3A (preset: \$3A 00 00)

D15	D14	D13	D12	D11	D10	D9	D8	D7	D6	D5	D4	D3	D2	D1	D0
0	FBON	FBSS	FBUP	FBV1	FBV0	0	TJD0	FPS1	FPS0	TPS1	TPS0	0	SJHD	INBK	MTI0

FBON: FBIAS (focus bias) register addition (on/off)
 The FBIAS register value is added to the signal loaded into the FCS In register by FBON = 1 (on).

FBSS: FBIAS (focus bias) register/counter switching
 FBSS = 0: register, FBSS = 1: counter.

FBUP: FBIAS (focus bias) counter up/down operation switching
 This performs counter up/down control when FBSS = 1. FBUP = 0: down counter, FBUP = 1: up counter.

FBV1, FBV0: FBIAS (focus bias) counter voltage switching
 The number of FCS BIAS count-up/-down steps per cycle is decided by these bits.

	FBV1	FBV0	Number of steps per cycle	
*	0	0	1	The counter changes once for each sampling cycle of the focus servo filter. When MCK is 128Fs, the sampling frequency is 88.2kHz. When converted to FE input, 1 step is approximately $1/2^9 \times V_{DD} \times 0.4$, V_{DD} = supply voltage.
	0	1	2	
	1	0	4	
	1	1	8	

*: preset

TJD0: This sets the tracking servo filter data RAM to 0 when switched from track jump to servo on only when SFJP = 1 (during surf jump operation).

FPS1, FPS0: Gain setting when transferring data from the focus filter to the PWM block.

TPS1, TPS0: Gain setting when transferring data from the tracking filter to the PWM block.

This is effective for increasing the overall gain in order to widen the servo band. Operation when FPS1, FPS0 (TPS1, TPS0) = 00 is the same as usual (7-bit shift). However, 6dB, 12dB and 18dB can be selected independently for focus and tracking by setting the relative gain to 0dB when FPS1, FPS0 (TPS1, TPS0) = 00.

	FPS1	FPS0	Relative gain		TPS1	TPS0	Relative gain	
*	0	0	0dB		0	0	0dB	*
	0	1	+6dB		0	1	+6dB	
	1	0	+12dB		1	0	+12dB	
	1	1	+18dB		1	1	+18dB	

*: preset

SJHD: This holds the tracking filter output at the value when surf jump starts during surf jump.

INBK: When INBK = 0 (off), the brake circuit masks the tracking drive signal with TRKCNCL which is generated by taking the MIRR signal at the TZC edge. When INBK = 1 (on), the tracking filter input is masked instead of the drive output.

MTI0: The tracking filter input is masked when the MIRR signal is high by setting MTI0 = 1 (on).

\$3B (preset: \$3B E0 50)

D15	D14	D13	D12	D11	D10	D9	D8	D7	D6	D5	D4	D3	D2	D1	D0
SFO2	SFO1	SDF2	SDF1	MAX2	MAX1	SFOX	BTF	D2V2	D2V1	D1V2	D1V1	RINT	0	0	0

SFOX, SFO2, SFO1: FOK slice level

Default value: 011 ($28/256 \times V_{DD} \times 0.57$, V_{DD} = supply voltage)

RFDC input conversion

SFOX	SFO2	SFO1	Slice level
0	0	0	$16/256 \times V_{DD} \times 0.57$
0	0	1	$20/256 \times V_{DD} \times 0.57$
0	1	0	$24/256 \times V_{DD} \times 0.57$
*	0	1	$28/256 \times V_{DD} \times 0.57$
1	0	0	$32/256 \times V_{DD} \times 0.57$
1	0	1	$40/256 \times V_{DD} \times 0.57$
1	1	0	$48/256 \times V_{DD} \times 0.57$
1	1	1	$50/256 \times V_{DD} \times 0.57$

*: preset

SDF2, SDF1: DFCT slice level
 Default value: 10 ($0.0313 \times V_{DD} \times 1.14V$)
 RFDC input conversion

SDF2	SDF1	Slice level
0	0	$0.0156 \times V_{DD} \times 1.14$
0	1	$0.0234 \times V_{DD} \times 1.14$
1	0	$0.0313 \times V_{DD} \times 1.14$
1	1	$0.0391 \times V_{DD} \times 1.14$

*: preset, V_{DD} : supply voltage

MAX2, MAX1: DFCT maximum time (MCK = 128Fs)
 Default value: 00 (no timer limit)

MAX2	MAX1	DFCT maximum time
0	0	No timer limit
0	1	2.00ms
1	0	2.36
1	1	2.72

*: preset

BTF: Bottom hold double-speed count-up mode for MIRR signal generation
 On/off (default: off)
 On when set to 1.

D2V2, D2V1: Peak hold 2 for DFCT signal generation
 Count-down speed setting
 Default value: 01 ($0.086 \times V_{DD} \times 1.14V/ms$, 44.1kHz)
 [V/ms] unit items indicate RFDC input conversion; [kHz] unit items indicate the operating frequency of the internal counter.

D2V2	D2V1	Count-down speed	
		[V/ms]	[kHz]
0	0	$0.0431 \times V_{DD} \times 1.14$	22.05
0	1	$0.0861 \times V_{DD} \times 1.14$	44.1
1	0	$0.172 \times V_{DD} \times 1.14$	88.2
1	1	$0.344 \times V_{DD} \times 1.14$	176.4

*: preset, V_{DD} : supply voltage

D1V2, D1V1: Peak hold 1 for DFCT signal generation
 Count-down speed setting
 Default value: 01 ($0.688 \times V_{DD} \times 1.14V/ms$, 352.8kHz)
 [V/ms] unit items indicate RFDC input conversion; [kHz] unit items indicate the operating frequency of the internal counter.

D2V2	D2V1	Count-down speed	
		[V/ms]	[kHz]
0	0	$0.344 \times V_{DD} \times 1.14$	176.4
0	1	$0.688 \times V_{DD} \times 1.14$	352.8
1	0	$1.38 \times V_{DD} \times 1.14$	705.6
1	1	$2.75 \times V_{DD} \times 1.14$	1411.2

*: preset, V_{DD} : supply voltage

RINT: This initializes the initial-state registers of the circuits which generate MIRR, DFCT and FOK.

\$3C (preset: \$3C 00 80)

D15	D14	D13	D12	D11	D10	D9	D8	D7	D6	D5	D4	D3	D2	D1	D0
COSS	COTS	CETZ	CETF	COT2	COT1	MOT2	0	BTS1	BTS0	MRC1	MRC0	0	0	0	0

COSS, COTS: These select the TZC signal used when generating the COUT signal.

Preset = HPTZC.

	COSS	COTS	TZC
*	1	—	STZC
	0	0	HPTZC
	0	1	DTZC

*: preset, —: don't care

STZC is the TZC generated by sampling the TE signal at 700kHz. (when MCK = 128Fs)

DTZC is the delayed phase STZC. (The delay amount can be selected by D14 of \$36.)

HPTZC is the fast phase TZC passed through a HPF with a cut-off frequency of 1kHz.

See §5-13.

CETZ: The input from the TE pin normally enters the TRK filter and is used to generate the TZC signal. However, the input from the CE pin can also be used. This function is for the center error servo.

When CETZ = 0, the TZC signal is generated by using the TE input signal.

When CETZ = 1, the TZC signal is generated by using the CE input signal.

CETF: When CETF = 0, the signal input to the TE pin is input to the TRK servo filter.

When CETF = 1, the signal input to the CE pin is input to the TRK servo filter.

These commands output the TZC signal.

COT2, COT1: This outputs the TZC signal from the COUT pin.

	COT2	COT1	COUT pin output
*	1	—	STZC
	0	1	HPTZC
	0	0	COUT

*: preset, —: don't care

MOT2: The STZC signal is output from the MIRR pin by setting MOT2 to 1.

These commands set the MIRR signal generation circuit.

BTS1, BTS0: This sets the count-up speed for the bottom hold value of the MIRR generation circuit. The time per step is approximately 708 ns (when MCK = 128Fs). The preset value is BTS1 = 1, BTS0 = 0. However, this is valid only when BTF of \$3B is 0.

MRC1, MRC0: This sets the minimum pulse width for masking the MIRR signal of the MIRR generation circuit. As noted in §5-9, the MIRR signal is generated by comparing the waveform obtained by subtracting the bottom hold value from the peak hold value with the MIRR comparator level. Strictly speaking, however, for MIRR to become high, these levels must be compared continuously for a certain time. This sets that time.

The preset value is MRC1 = 0, MRC0 = 0.

	BTS1	BTS0	Number of count-up steps per cycle
*	0	0	1
	0	1	2
	1	0	4
	1	1	8

	MRC1	MRC0	Setting time [μs]
	0	0	5.669 *
	0	1	11.338
	1	0	22.675
	1	1	45.351

*: preset (when MCK = 128Fs)

\$3D (preset: \$3D 00 00)

D15	D14	D13	D12	D11	D10	D9	D8	D7	D6	D5	D4	D3	D2	D1	D0
SFID	SFSK	THID	THSK	0	TLD2	TLD1	TLD0	0	0	0	0	0	0	0	0

SFID: SLED servo filter input can be obtained not from SLD in Reg, but from M0D, which is the TRK filter second-stage output.

When the low-frequency component of the tracking error signal obtained from the RF amplifier is attenuated, the low frequency can be amplified and input to the SLD servo filter.

SFSK: Only during TRK servo gain up2 operation, coefficient K30 is used instead of K00. Normally the DC gain between the TE input pin and M0D changes for TRK filter gain normal and gain up2, and error occurs in the DC level at M0D. In this case, the DC level of the signal transmitted to M00 can be kept uniform by adjusting the K30 value even during the above switching.

THID: TRK hold filter input can be obtained not from SLD in Reg, but from M0D, which is the TRK filter second-stage output.

When signals other than the tracking error signal from the RF amplifier are input to the SE input pin, the signal transmitted from the TE pin can be obtained as TRK hold filter input.

THSK: Only during TRK servo gain up2 operation, coefficient K46 is used instead of K40. Normally the DC gain between the TE input pin and M0D changes for TRK filter gain normal and gain up 2, and error occurs in the DC level at M0D. In this case, the DC level of the signal transmitted to M18 can be kept uniform by adjusting the K46 value even during the above switching.

* Please refer to § 5-21. Filter Composition, for further information on SFID, SFSK, THID and THSK commands.

TLD0 to 2: SLD filter correction turns on and off independently of the TRK filter. Please refer also to \$38 (TLC0 to 2) and Figure 5-3.

TLC2	TLD2	Traverse center correction	
		TRK filter	SLD filter
0	—	OFF	OFF
1	0	ON	ON
	1	ON	OFF

TLC1	TLD1	Tracking zero level correction	
		TRK filter	SLD filter
0	—	OFF	OFF
1	0	ON	ON
	1	ON	OFF

TLC0	TLD0	VC level correction	
		TRK filter	SLD filter
0	—	OFF	OFF
1	0	ON	ON
	1	ON	OFF

*: preset, — : Don't care

- Input coefficient inversion when SFID = 1 and THID = 1

The preset coefficients for the TRK filter are negative for input and positive for output. With this, the error input and servo that outputs reversed phase drive can be hypothesized.

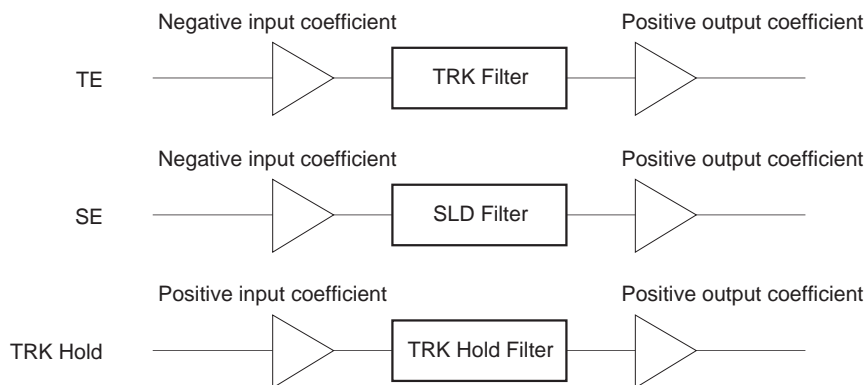

When SFID = 1, the TRK filter negative input coefficient is applied to the SLD filter, so invert the SLD input coefficient (K00) code.

For the same reason, when THID = 1, invert the TRK hold input coefficient (K40) code.

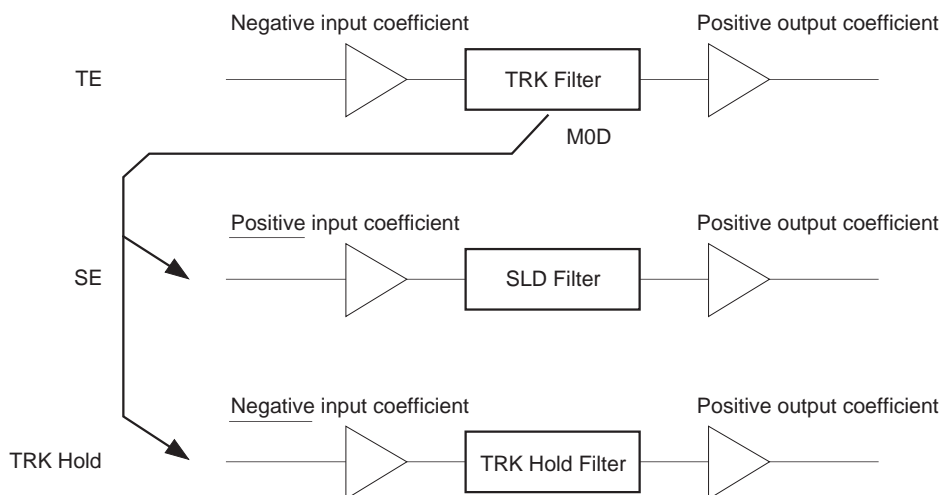

Please refer also to § 5-20. Filter Composition.

\$3E (preset: \$3E 00 00)

D15	D14	D13	D12	D11	D10	D9	D8	D7	D6	D5	D4	D3	D2	D1	D0
F1NM	F1DM	F3NM	F3DM	T1NM	T1UM	T3NM	T3UM	DFIS	TLCD	0	LKIN	COIN	MDFI	MIRI	XT1D

F1NM, F1DM: Quasi double accuracy setting for FCS servo filter first-stage
On when set to 1; default = 0.

F1NM: Gain normal
F1DM: Gain down

T1NM, T1UM: Quasi double accuracy setting for TRK servo filter first-stage
On when set to 1; default = 0.

T1NM: Gain normal
T1UM: Gain up

F3NM, F3DM: Quasi double accuracy setting for FCS servo filter third-stage
On when set to 1; default = 0.

Generally, the advance amount of the phase becomes large by partially setting the FCS servo third-stage filter which is used as the phase compensation filter to double accuracy.

F3NM: Gain normal
F3DM: Gain down

T3NM, T3UM: Quasi double accuracy setting for TRK servo filter third-stage
On when set to 1; default = 0.

Generally, the advance amount of the phase becomes large by partially setting the TRK servo third-stage filter which is used as the phase compensation filter to double accuracy.

T3NM: Gain normal
T3UM: Gain up

Note) Filter first- and third-stage quasi double accuracy settings can be set individually.
See "Filter Composition" at the end of this specification concerning quasi double accuracy.

DFIS: FCS hold filter input extraction node selection
0: M05 (Data RAM address 05); default
1: M04 (Data RAM address 04)

TLCD: This command masks the TLC2 command set by D2 of \$38 only when FOK is low.
On when set to 1; default = 0

LKIN: When 0, the internally generated LOCK signal is output to the LOCK pin. (default)
When 1, the LOCK signal can be input from an external source to the LOCK pin.

COIN: When 0, the internally generated COUT signal is output to the COUT pin. (default)
When 1, the COUT signal can be input from an external source to the COUT pin.
The MIRR, DFCT and FOK signals can also be input from an external source.

MDFI: When 0, the MIRR, DFCT and FOK signals are generated internally. (default)
When 1, the MIRR, DFCT and FOK signals can be input from an external source through the MIRR, DFCT and FOK pins.

MIRI: When 0, the MIRR signal is generated internally. (default)
When 1, the MIRR signal can be input from an external source through the MIRR pin.

	MDFI	MIRI	
*	0	0	MIRR, DFCT and FOK are all generated internally.
	0	1	MIRR only is input from an external source.
	1	—	MIRR, DFCT and FOK are all input from an external source.

*: preset, —: don't care

XT1D: The clock input from FSTI can be used without being frequency-divided as the master clock for the servo block by setting D0 to 1. This command takes precedence over the XTSL pin, XT2D and XT4D. See the description of \$3F for XT2D and XT4D.

\$3F (preset: \$3F 00 00)

D15	D14	D13	D12	D11	D10	D9	D8	D7	D6	D5	D4	D3	D2	D1	D0
0	AGG4	XT4D	XT2D	0	DRR2	DRR1	DRR0	0	ASFG	FTQ	LPAS	SRO1	0	AGHF	ASOT

AGG4: This varies the amplitude of the internally generated sine wave using the AGGF and AGGT commands during AGC.
When AGG4 = 0, the default is used. When AGG4 = 1, the setting is as shown in the table below.

	AGGF (MSB)	AGGT (LSB)	TE/FE input conversion
*	0	0	$1/64 \times V_{DD} \times 0.4$ [V]
	0	1	$1/32 \times V_{DD} \times 0.4$
	1	0	$1/16 \times V_{DD} \times 0.4$
	1	1	$1/8 \times V_{DD} \times 0.4$

These settings are the same for both focus auto gain control and tracking auto gain control.

*: preset

XT4D, XT2D: MCK (digital servo master clock) frequency division setting
This command forcibly sets the frequency division ratio to 1/4, 1/2 or 1/1 when MCK is generated from the signal input to the FSTI pin. See the description of \$3E for XT1D.

	XT1D	XT2D	XT4D	Frequency division ratio
*	0	0	0	According to XTSL
	1	—	—	1/1
	0	1	—	1/2
	0	0	1	1/4

*: preset, —: don't care

DRR2 to DRR0: Partially clears the Data RAM values (0 write).
The following values are cleared when set to 1 (on) respectively; default = 0

- DRR2: M08, M09, M0A
- DRR1: M00, M01, M02
- DRR0: M00, M01, M02 only when LOCK = low

Note) Set DRR1 and DRR0 on for 50µs or more.

ASFG: When vibration detection is performed during anti-shock circuit operation, FCS servo filter is forcibly set to gain normal status.

On when set to 1; default = 0

LPAS: Built-in analog buffer low-current consumption mode

This mode reduces the total analog buffer current consumption for the VC, TE, SE and FE input analog buffers by using a single operational amplifier.

On when set to 1; default = 0

Note) When using this mode, first check whether each error signal is properly A/D converted using the SRO1 and SRO0 commands of \$3F.

SRO1: These commands are used to output various data externally continuously which have been specified with the \$39 command. (However, D15 (DAC) of \$39 must be set to 1.)

Digital output (SOCK, XOLT and SOUT) can be obtained from three specified pins by setting these commands to 1 respectively. The default is 0, 0. (no readout)

The output pins for each case are shown below.

	SRO1 = 1
SOCK	LMUT pin
XOLT	WFCK pin
SOUT	RMUT pin

(See "Description of Data Readout" on the following page.)

AGHF: This halves the frequency of the internally generated sine wave during AGC.

FTQ: The slope of the output during focus search is a quarter of the conventional output slope. ON when set to 1, default = 0.

ASOT: The anti-shock signal, which is internally detected, is output from the ATSK pin. Output when set to 1; default = 0.

Vibration detection when a high signal is output for the anti-shock signal output.

Description of Data Readout

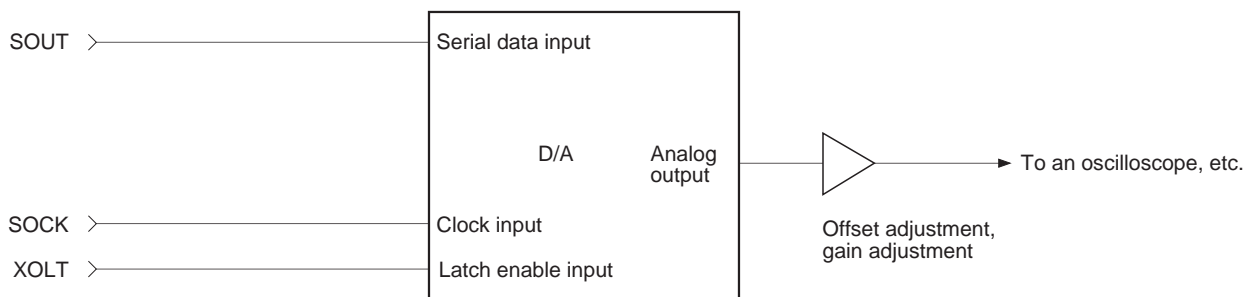
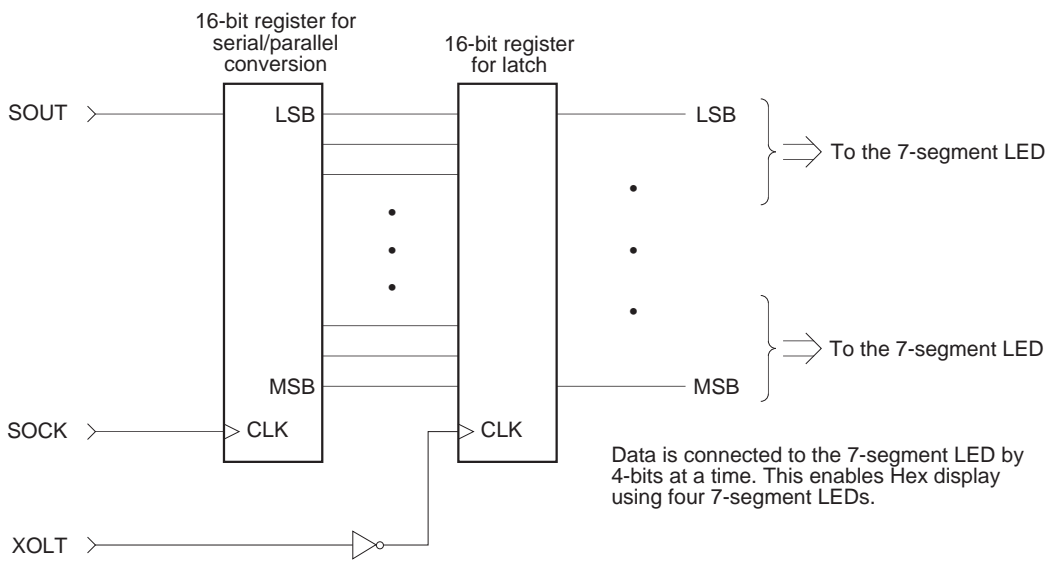
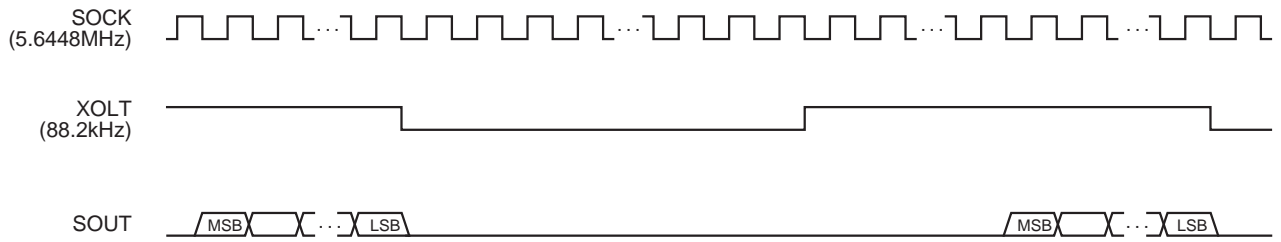

Waveforms can be monitored with an oscilloscope using a serial input-type D/A converter as shown above.

§5-19. List of Servo Filter Coefficients

<Coefficient Preset Value Table (1)>

ADDRESS	DATA	CONTENTS
K00	E0	SLED INPUT GAIN
K01	81	SLED LOW BOOST FILTER A-H
K02	23	SLED LOW BOOST FILTER A-L
K03	7F	SLED LOW BOOST FILTER B-H
K04	6A	SLED LOW BOOST FILTER B-L
K05	10	SLED OUTPUT GAIN
K06	14	FOCUS INPUT GAIN
K07	30	SLED AUTO GAIN
K08	7F	FOCUS HIGH CUT FILTER A
K09	46	FOCUS HIGH CUT FILTER B
K0A	81	FOCUS LOW BOOST FILTER A-H
K0B	1C	FOCUS LOW BOOST FILTER A-L
K0C	7F	FOCUS LOW BOOST FILTER B-H
K0D	58	FOCUS LOW BOOST FILTER B-L
K0E	82	FOCUS PHASE COMPENSATE FILTER A
K0F	7F	FOCUS DEFECT HOLD GAIN
K10	4E	FOCUS PHASE COMPENSATE FILTER B
K11	32	FOCUS OUTPUT GAIN
K12	20	ANTI SHOCK INPUT GAIN
K13	30	FOCUS AUTO GAIN
K14	80	HPTZC / Auto Gain HIGH PASS FILTER A
K15	77	HPTZC / Auto Gain HIGH PASS FILTER B
K16	80	ANTI SHOCK HIGH PASS FILTER A
K17	77	HPTZC / Auto Gain LOW PASS FILTER B
K18	00	Fix*
K19	F1	TRACKING INPUT GAIN
K1A	7F	TRACKING HIGH CUT FILTER A
K1B	3B	TRACKING HIGH CUT FILTER B
K1C	81	TRACKING LOW BOOST FILTER A-H
K1D	44	TRACKING LOW BOOST FILTER A-L
K1E	7F	TRACKING LOW BOOST FILTER B-H
K1F	5E	TRACKING LOW BOOST FILTER B-L
K20	82	TRACKING PHASE COMPENSATE FILTER A
K21	44	TRACKING PHASE COMPENSATE FILTER B
K22	18	TRACKING OUTPUT GAIN
K23	30	TRACKING AUTO GAIN
K24	7F	FOCUS GAIN DOWN HIGH CUT FILTER A
K25	46	FOCUS GAIN DOWN HIGH CUT FILTER B
K26	81	FOCUS GAIN DOWN LOW BOOST FILTER A-H
K27	3A	FOCUS GAIN DOWN LOW BOOST FILTER A-L
K28	7F	FOCUS GAIN DOWN LOW BOOST FILTER B-H
K29	66	FOCUS GAIN DOWN LOW BOOST FILTER B-L
K2A	82	FOCUS GAIN DOWN PHASE COMPENSATE FILTER A
K2B	44	FOCUS GAIN DOWN DEFECT HOLD GAIN
K2C	4E	FOCUS GAIN DOWN PHASE COMPENSATE FILTER B
K2D	1B	FOCUS GAIN DOWN OUTPUT GAIN
K2E	00	NOT USED
K2F	00	NOT USED

* Fix indicates that normal preset values.

<Coefficient Preset Value Table (2)>

ADDRESS	DATA	CONTENTS
K30	80	SLED INPUT GAIN (Only when TRK Gain Up2 is accessed with SFSK = 1.)
K31	66	ANTI SHOCK LOW PASS FILTER B
K32	00	NOT USED
K33	7F	ANTI SHOCK HIGH PASS FILTER B-H
K34	6E	ANTI SHOCK HIGH PASS FILTER B-L
K35	20	ANTI SHOCK FILTER COMPARATE GAIN
K36	7F	TRACKING GAIN UP2 HIGH CUT FILTER A
K37	3B	TRACKING GAIN UP2 HIGH CUT FILTER B
K38	80	TRACKING GAIN UP2 LOW BOOST FILTER A-H
K39	44	TRACKING GAIN UP2 LOW BOOST FILTER A-L
K3A	7F	TRACKING GAIN UP2 LOW BOOST FILTER B-H
K3B	77	TRACKING GAIN UP2 LOW BOOST FILTER B-L
K3C	86	TRACKING GAIN UP PHASE COMPENSATE FILTER A
K3D	0D	TRACKING GAIN UP PHASE COMPENSATE FILTER B
K3E	57	TRACKING GAIN UP OUTPUT GAIN
K3F	00	NOT USED
K40	04	TRACKING HOLD FILTER INPUT GAIN
K41	7F	TRACKING HOLD FILTER A-H
K42	7F	TRACKING HOLD FILTER A-L
K43	79	TRACKING HOLD FILTER B-H
K44	17	TRACKING HOLD FILTER B-L
K45	6D	TRACKING HOLD FILTER OUTPUT GAIN
K46	00	TRACKING HOLD FILTER INPUT GAIN (Only when TRK Gain Up2 is accessed with THSK = 1.)
K47	00	NOT USED
K48	02	FOCUS HOLD FILTER INPUT GAIN
K49	7F	FOCUS HOLD FILTER A-H
K4A	7F	FOCUS HOLD FILTER A-L
K4B	79	FOCUS HOLD FILTER B-H
K4C	17	FOCUS HOLD FILTER B-L
K4D	54	FOCUS HOLD FILTER OUTPUT GAIN
K4E	00	NOT USED
K4F	00	NOT USED

§5-20. Filter Composition

The internal filter composition is shown below.

K** and M** indicate coefficient RAM and Data RAM address values respectively.

FCS Servo Gain Normal $f_s = 88.2\text{kHz}$

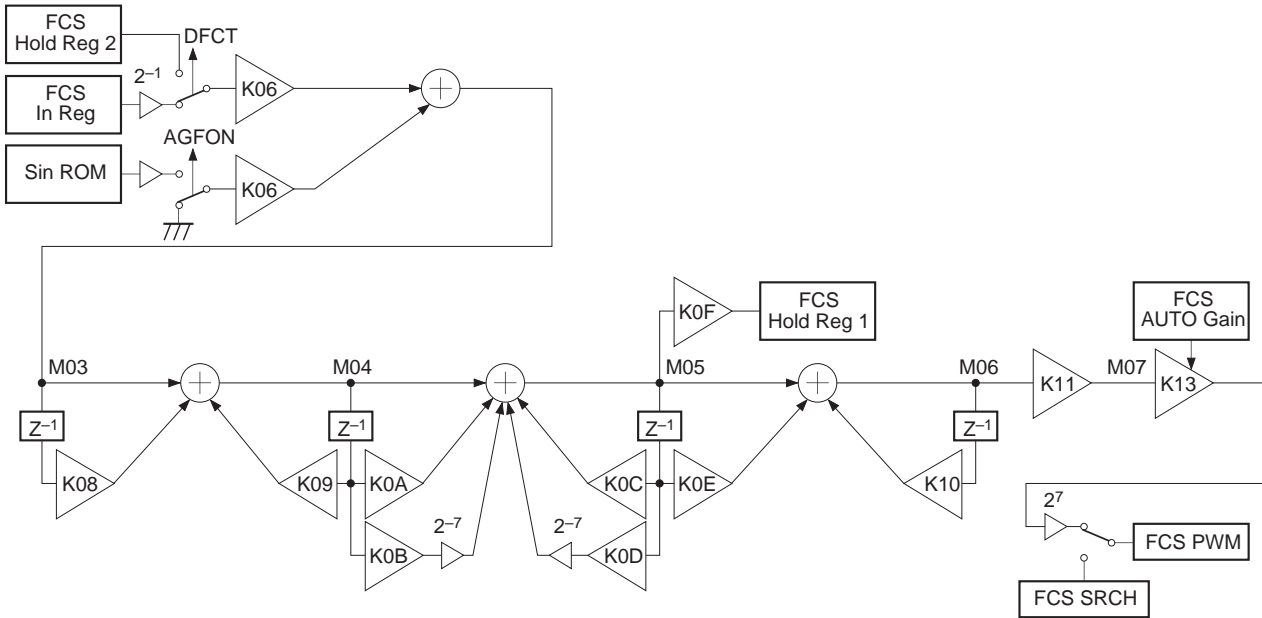

Note) Set the MSB bit of the K0B and K0D coefficients to 0.

FCS Servo Gain Down $f_s = 88.2\text{kHz}$

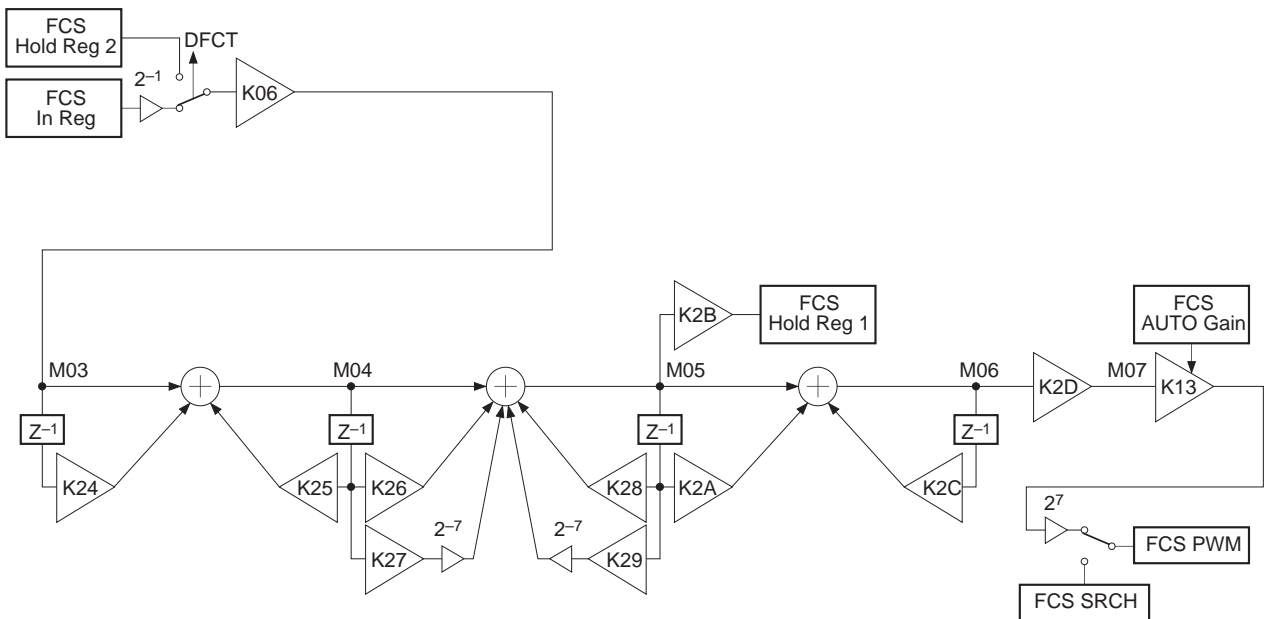

Note) Set the MSB bit of the K27 and K29 coefficients to 0.

TRK Servo Gain Normal fs = 88.2kHz

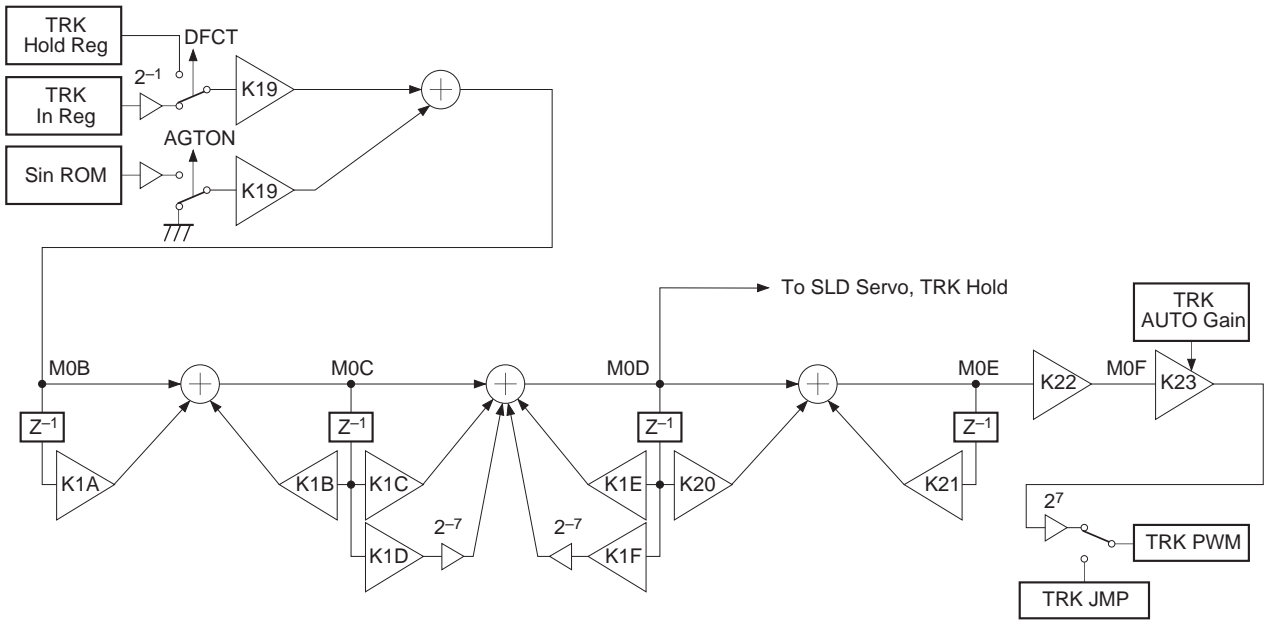

Note) Set the MSB bit of the K1D and K1F coefficients to 0.

TRK Servo Gain Up 1 fs = 88.2kHz

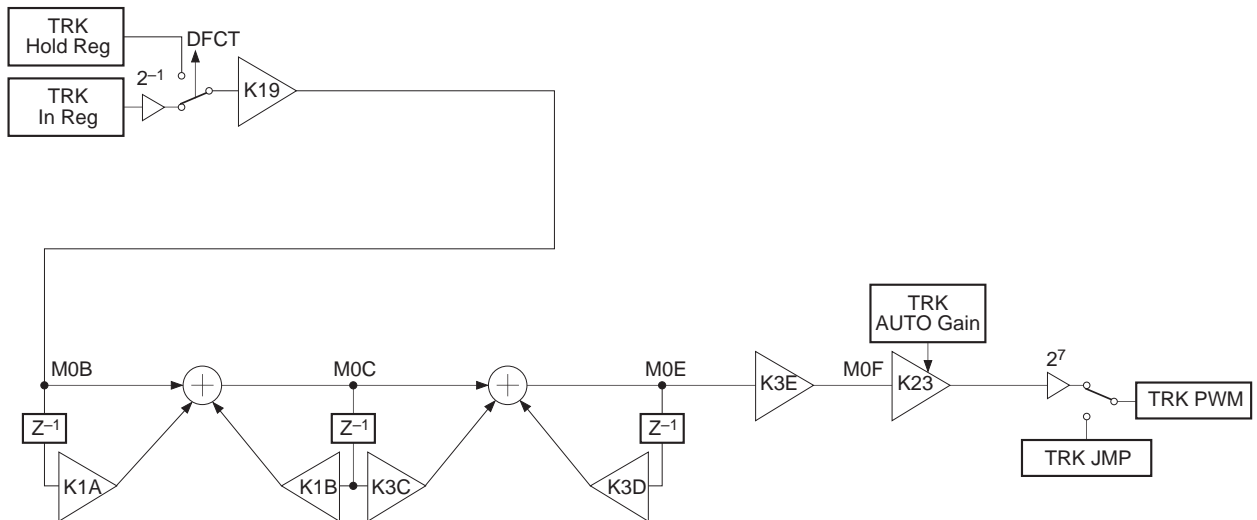

TRK Servo Gain Up 2 fs = 88.2kHz

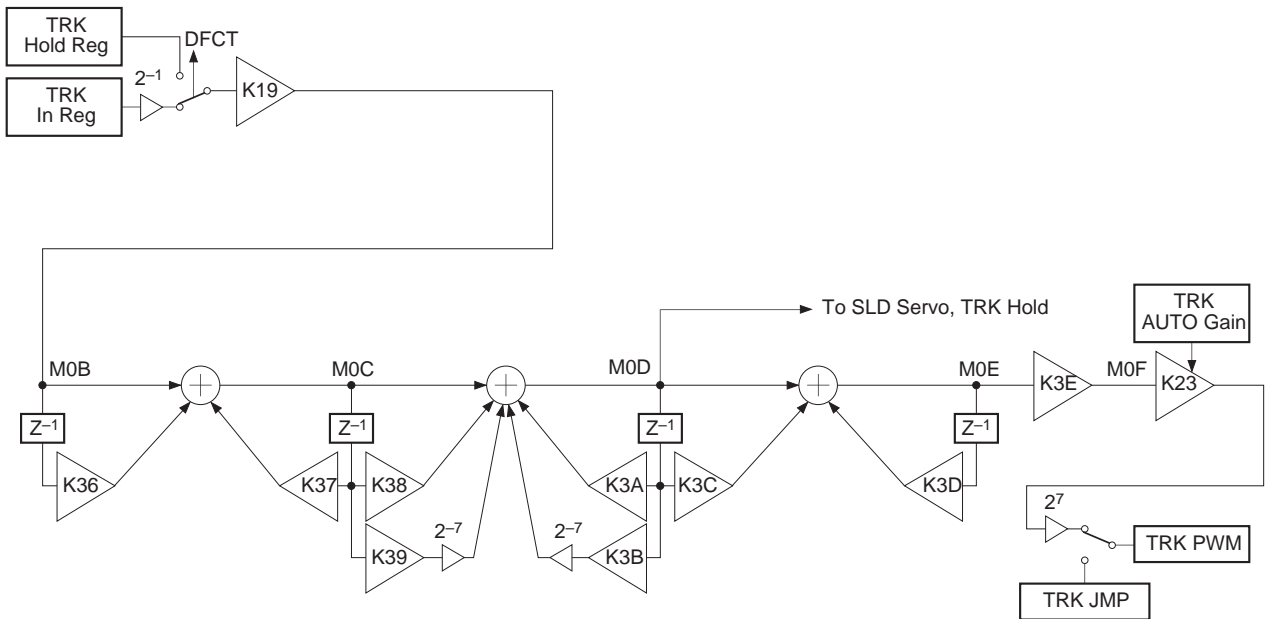

Note) Set the MSB bit of the K39 and K3B coefficients to 0.

SLD Servo fs = 345Hz

TRK SERVO FILTER
Second-stage output

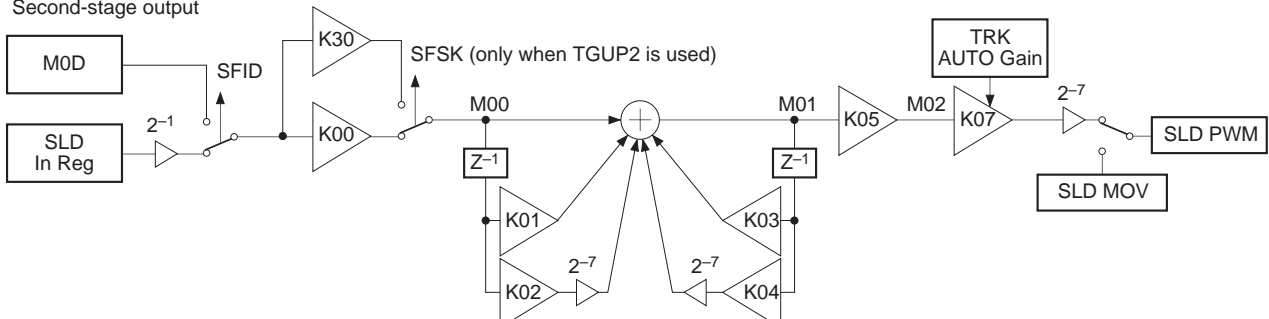

Note) Set the MSB bit of the K02 and K04 coefficients to 0.

HPTZC/Auto Gain fs = 88.2kHz

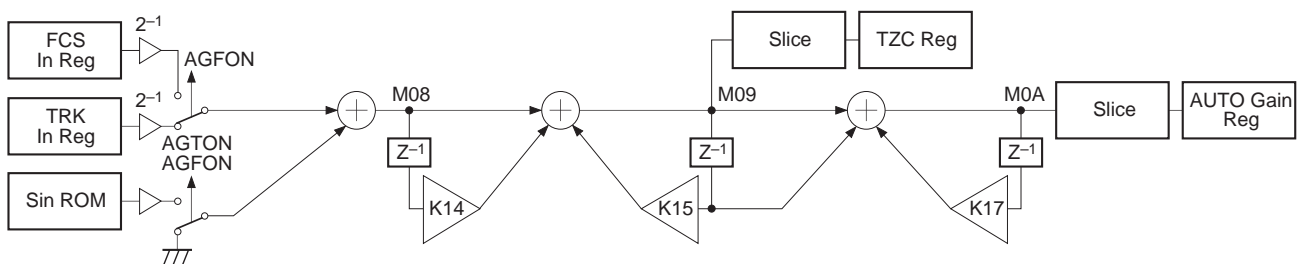

Anti Shock $f_s = 88.2\text{kHz}$

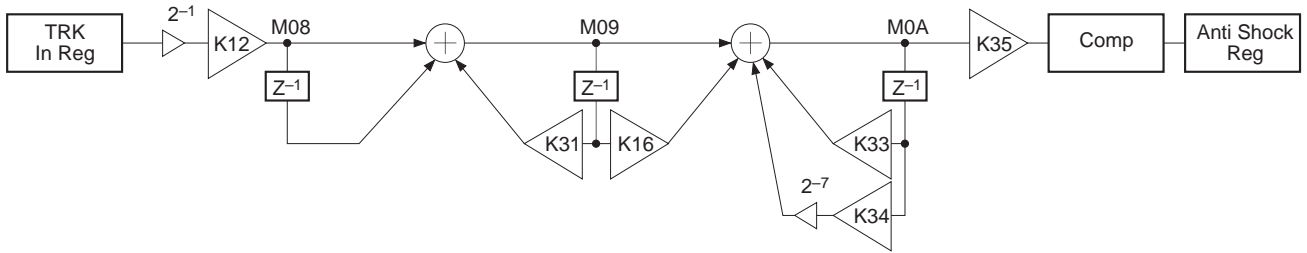

Note) Set the MSB bit of the K34 coefficient to 0.
The comparator input is 1/16 the maximum amplitude of the comparator input.

AVRG $f_s = 88.2\text{kHz}$

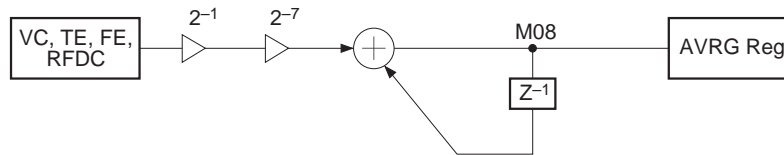

TRK Hold $f_s = 345\text{Hz}$

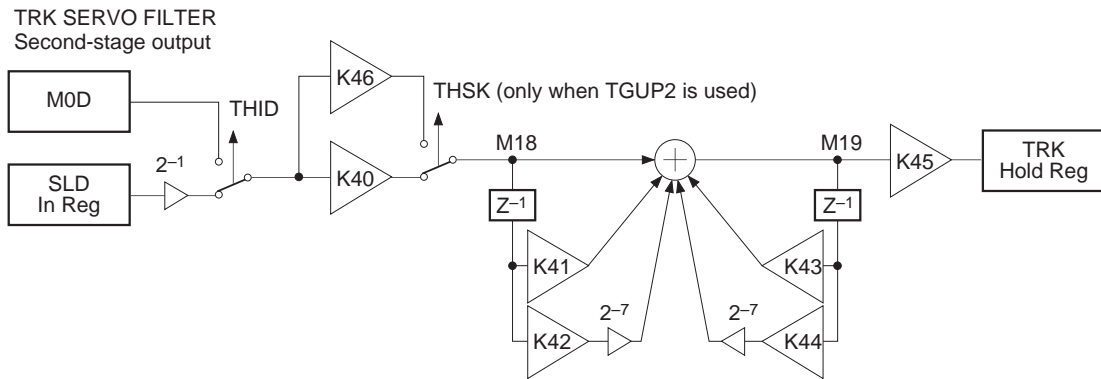

Note) Set the MSB bit of the K42 and K44 coefficients to 0.

FCS Hold $f_s = 345\text{Hz}$

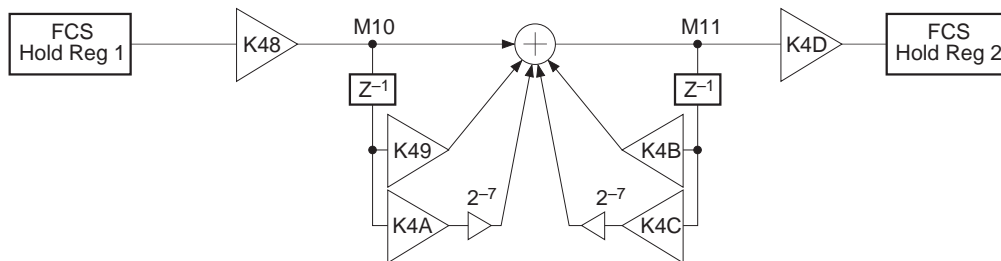

Note) Set the MSB bit of the K4A and K4C coefficients to 0.

FCS Servo Gain Normal; $F_s = 88.2\text{kHz}$, during quasi double accuracy (Ex.: \$3EAXX0)

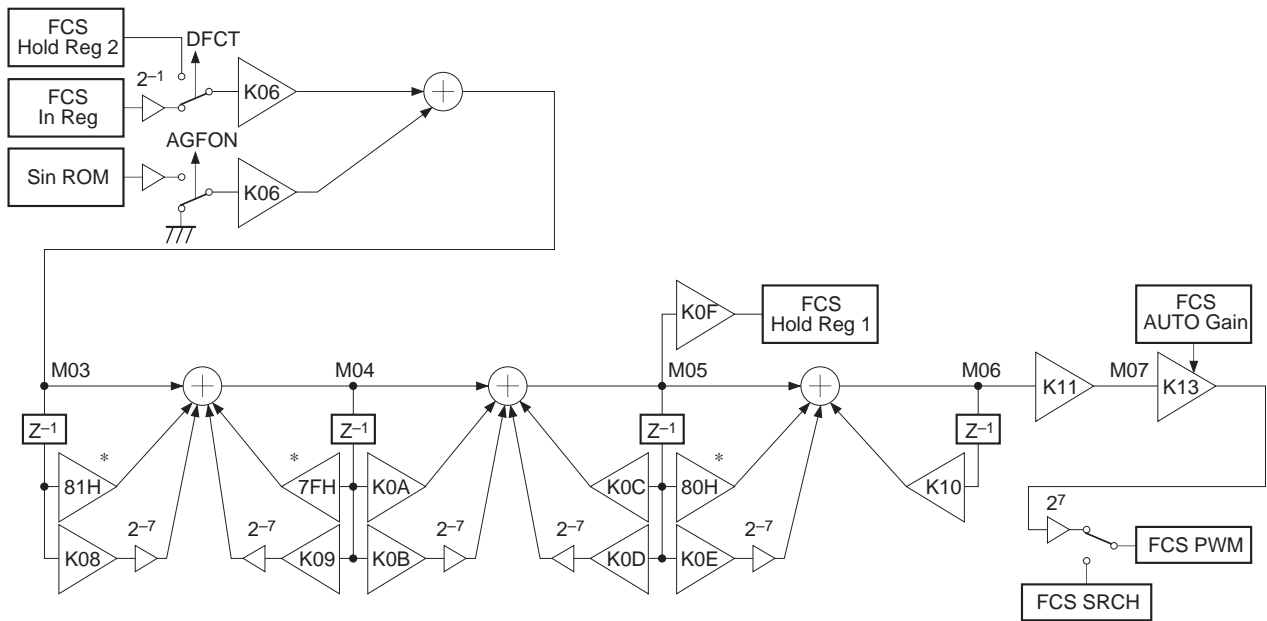

* 81H, 7FH and 80H are each Hex display 8-bit fixed values when set to quasi double accuracy.

Note) Set the MSB bit of the K0B and K0D coefficients during normal operation, and of the K08, K09 and K0E coefficients during quasi double accuracy to 0.

FCS Servo Gain Down; $F_s = 88.2\text{kHz}$, during quasi double accuracy (Ex.: \$3E5XX0)

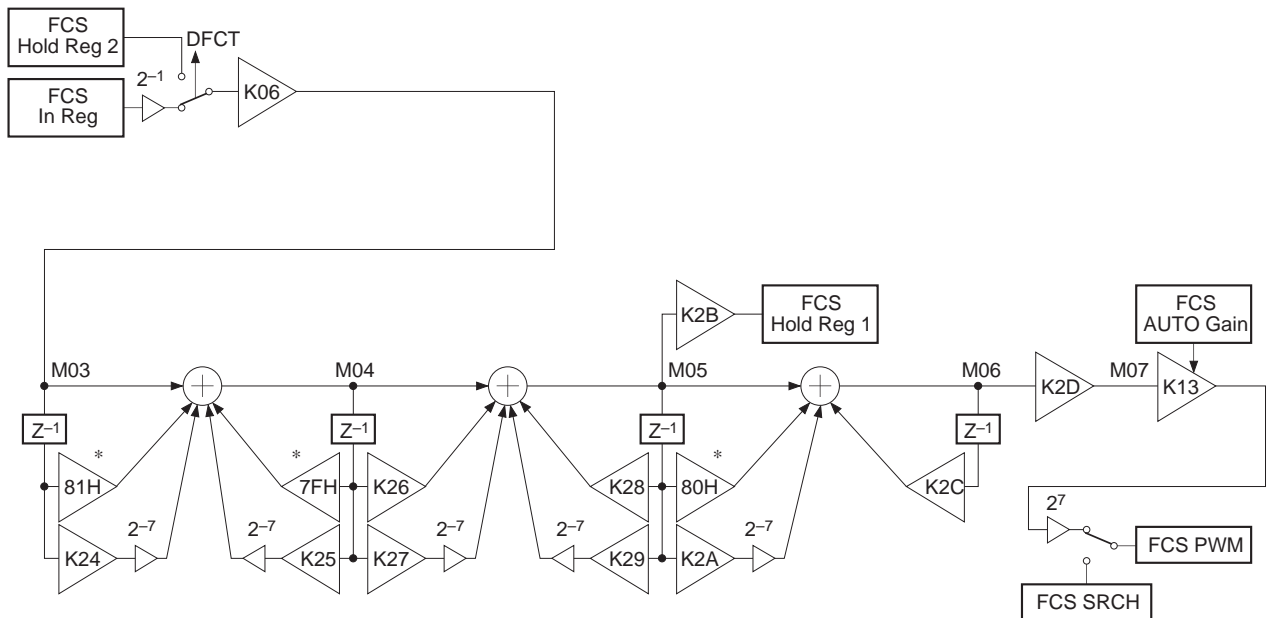

* 81H, 7FH and 80H are each Hex display 8-bit fixed values when set to quasi double accuracy.

Note) Set the MSB bit of the K27 and K29 coefficients during normal operation, and of the K24, K25 and K2A coefficients during quasi double accuracy to 0.

TRK Servo Gain Normal; $F_s = 88.2\text{kHz}$, during quasi double accuracy (Ex.: \$3EXAX0)

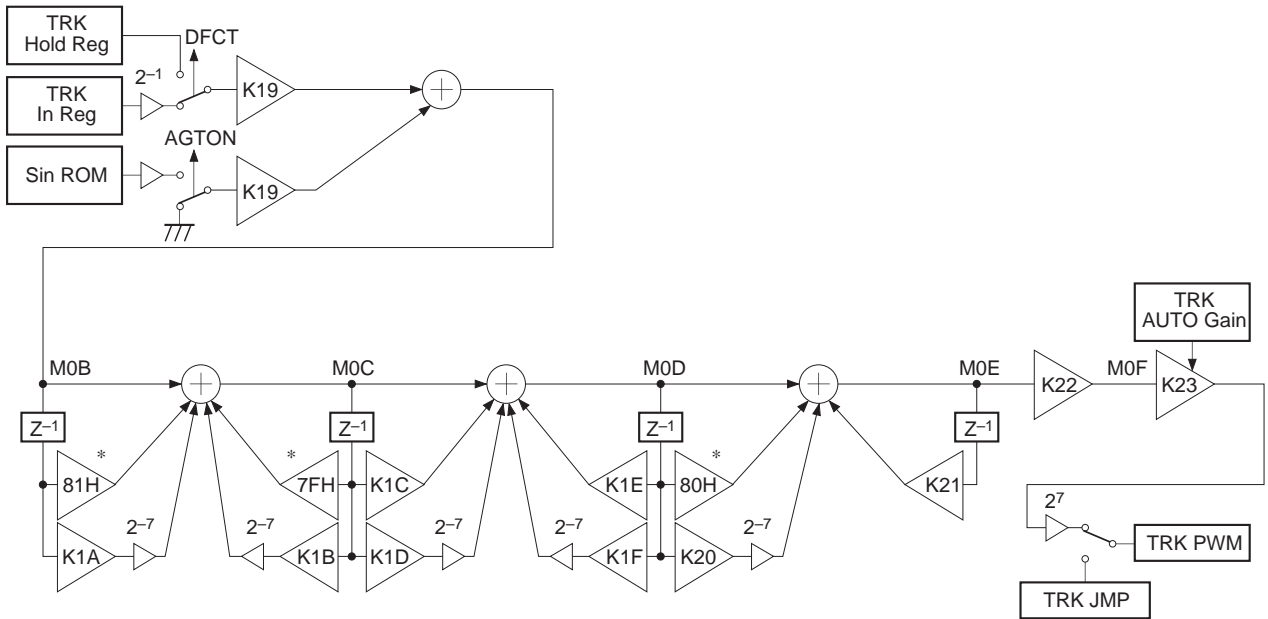

* 81H, 7FH and 80H are each Hex display 8-bit fixed values when set to quasi double accuracy.

Note) Set the MSB bit of the K1D and K1F coefficients during normal operation, and of the K1A, K1B and K20 coefficients during quasi double accuracy to 0.

TRK Servo Gain up 1; $F_s = 88.2\text{kHz}$, during quasi double accuracy (Ex.: \$3EX5X0)

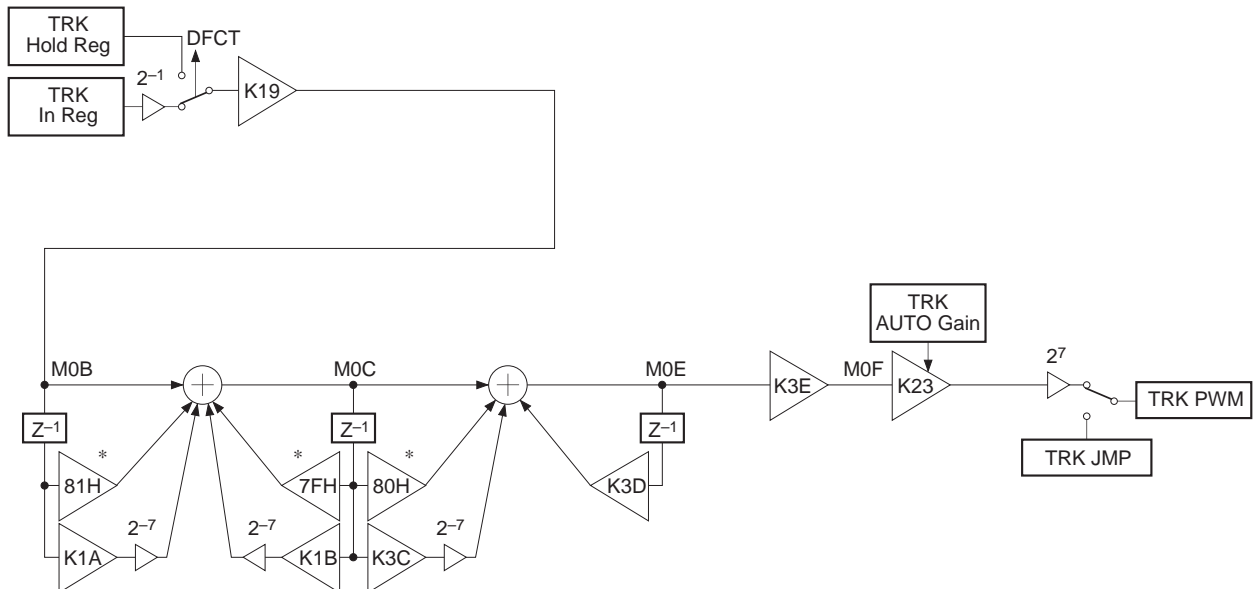

* 81H, 7FH and 80H are each Hex display 8-bit fixed values when set to quasi double accuracy.

Note) Set the MSB bit of the K1A, K1B and K3C coefficients during quasi double accuracy to 0.

TRK Servo Gain up 2; Fs = 88.2kHz, during quasi double accuracy (Ex.: \$3EX5X0)

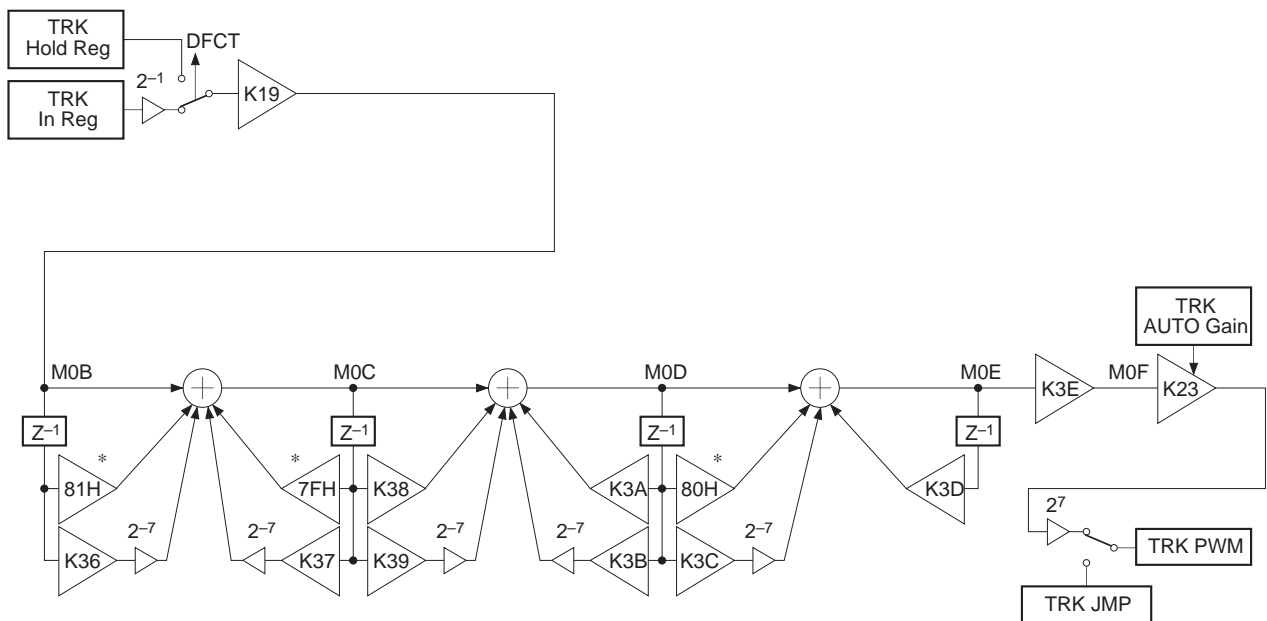

* 81H, 7FH and 80H are each Hex display 8-bit fixed values when set to quasi double accuracy.

Note) Set the MSB bit of the K39 and K3B coefficients during normal operation, and of the K36, K37 and K3C coefficients during quasi double accuracy to 0.

§5-21. TRACKING and FOCUS Frequency Response

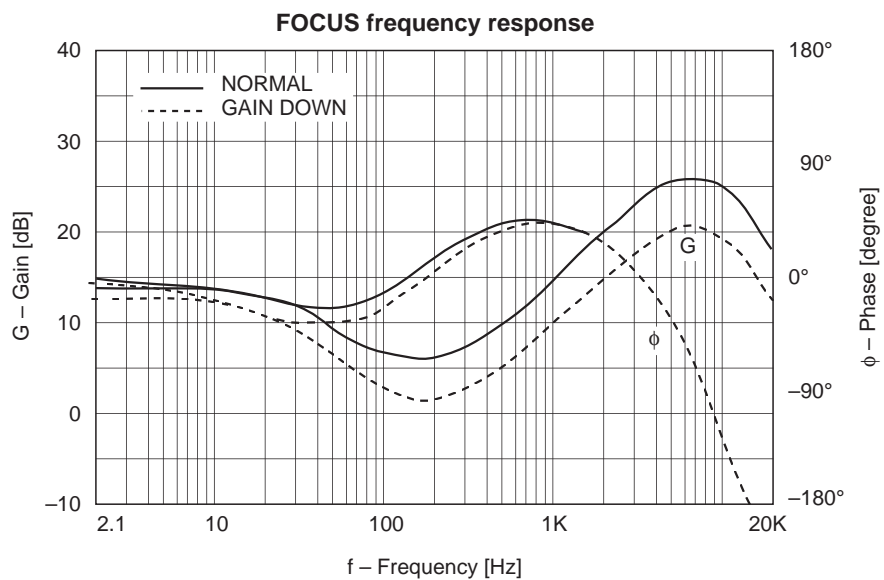
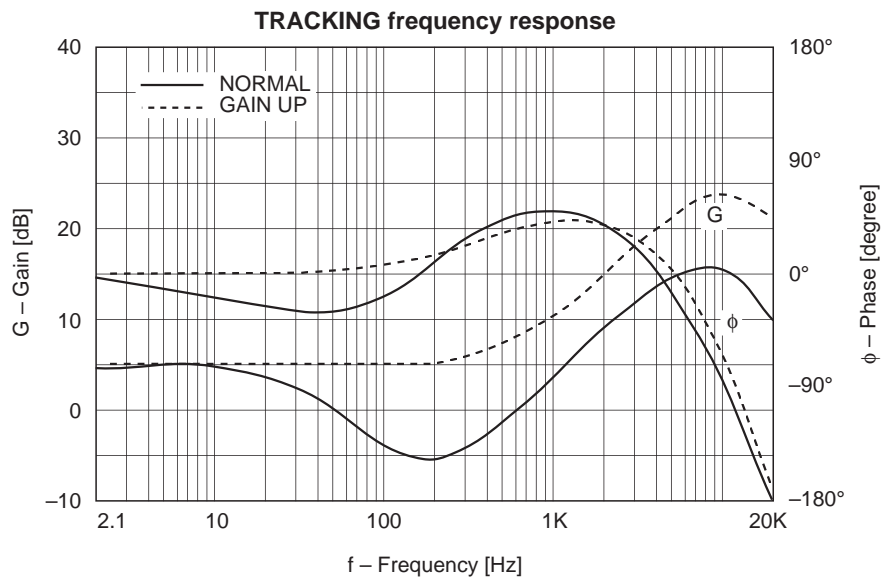

Package Outline

Unit: mm

CXD2588Q

100PIN QFP (PLASTIC)

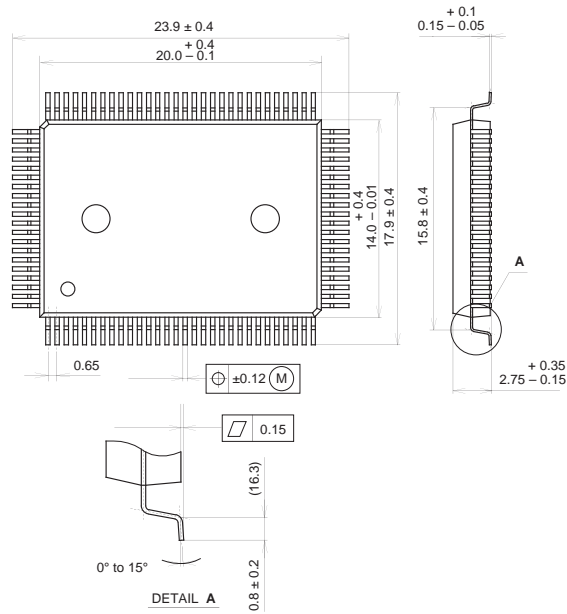

PACKAGE STRUCTURE

SONY CODE	QFP-100P-L01
EIAJ CODE	*QFP100-P-1420-A
JEDEC CODE	

PACKAGE MATERIAL	EPOXY RESIN
LEAD TREATMENT	SOLDER PLATING
LEAD MATERIAL	COPPER / 42 ALLOY
PACKAGE WEIGHT	1.4g

CXD2588R

100PIN LQFP (PLASTIC)

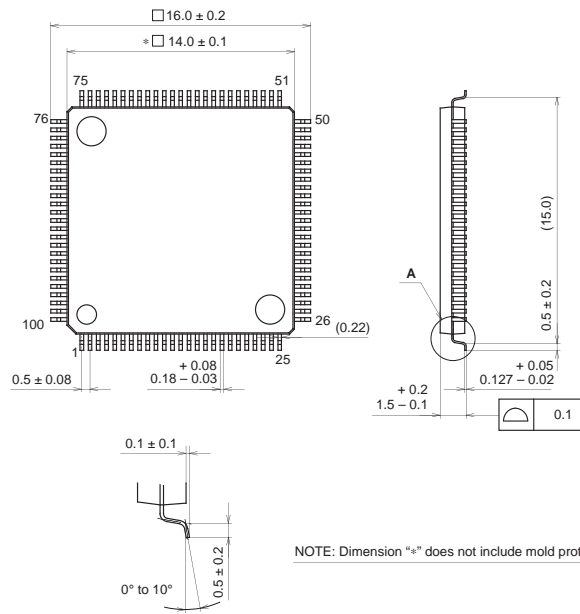

NOTE: Dimension "*" does not include mold protrusion.

PACKAGE STRUCTURE

SONY CODE	LQFP-100P-L01
EIAJ CODE	*QFP100-P-1414-A
JEDEC CODE	

PACKAGE MATERIAL	EPOXY/PHENOL RESIN
LEAD TREATMENT	SOLDER PLATING
LEAD MATERIAL	42 ALLOY
PACKAGE WEIGHT	

This datasheet has been downloaded from:

www.DatasheetCatalog.com

Datasheets for electronic components.



LittleDiode supplies new, hard to find or obsolete electronic components and semiconductors all over the world.

With over two million different components listed you are sure to find the part you need.

Feel free to visit us today at our online store:

LittleDiode.com

Looking forward to providing you with the best possible service.