

**Timing Generator for LCD Panels**

**Description**

The CXD2436Q is a timing signal generator for the VGA LCD panel LCX012 driver. This chip has a built-in serial interface circuit which allows the mode to be switched with respect to various VGA signals through direct control from an external microcomputer, etc.

**Features**

- Generates the LCX012 drive pulse.
- Supports three-panel projectors.
- Built-in serial interface circuit
- Supports various VGA signals. (non-interlaced mode)
- Built-in 2-line pair drive circuits
- Supports NTSC and PAL systems.
- Supports up/down and/or right/left inversion.
- Supports line inversion and field inversion.
- Generates timing signal of external sample-and-hold circuit.

**Applications**

LCD projectors, etc.

**Structure**

Silicon gate CMOS IC

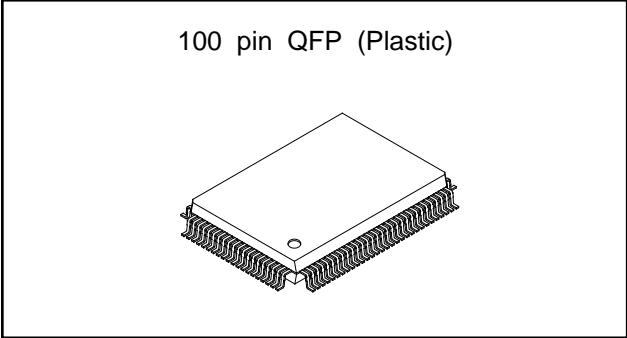

**Absolute Maximum Ratings (Ta=25 °C)**

- Supply voltage           V<sub>DD</sub>   V<sub>SS</sub>-0.5 to +7.0   V
- Input voltage            V<sub>I</sub>    V<sub>SS</sub>-0.5 to V<sub>DD</sub>+0.5   V
- Output voltage          V<sub>O</sub>   V<sub>SS</sub>-0.5 to V<sub>DD</sub>+0.5   V
- Operating temperature
 

T <sub>opr</sub>	-20 to +75	°C
------------------	------------	----
- Storage temperature
 

T <sub>stg</sub>	-55 to +150	°C
------------------	-------------	----

**Recommended Operating Conditions**

- Supply voltage           V<sub>DD</sub>   +4.5 to +5.5    V
- Supply voltage           V<sub>CC</sub>   -20 to +75      °C

Sony reserves the right to change products and specifications without prior notice. This information does not convey any license by any implication or otherwise under any patents or other right. Application circuits shown, if any, are typical examples illustrating the operation of the devices. Sony cannot assume responsibility for any problems arising out of the use of these circuits.

Block Diagram

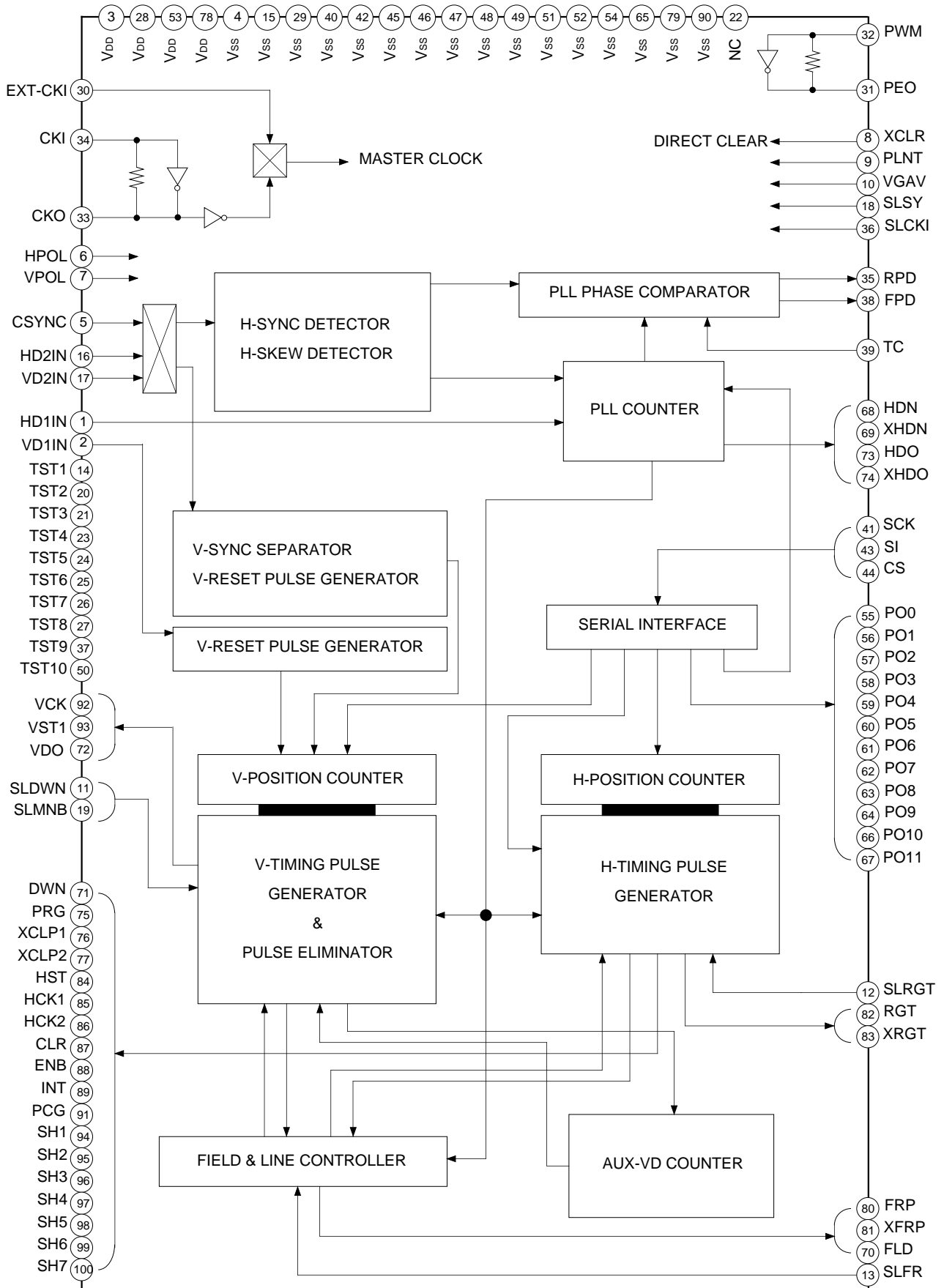

## Pin Description

Pin No.	Symbol	I/O	Description	Input pin for open status
1	HD1IN	I	Hsync input (VGA)	—
2	VD1IN	I	Vsync input (VGA)	—
3	V <sub>DD</sub>	—	Power supply	—
4	V <sub>SS</sub>	—	GND	—
5	CSYNC	I	Composite sync input (NTSC/PAL)	—
6	HPOL	I	HD, CSYNC polarity identification input (High: positive polarity, Low: negative polarity)	H
7	VPOL	I	VD, CSYNC polarity identification input (High: positive polarity, Low: negative polarity)	H
8	XCLR	I	External clear (all clear when Low)	H
9	PLNT	I	PAL/NTSC switching (High: NTSC, Low: PAL)	H
10	VGAV	I	VGA (NTSC/PAL) switching (High: VGA, Low: NTSC/PAL)	H
11	SLDWN	I	Up/down inversion discrimination signal input (High: Down, Low: Up)	H
12	SLRGT	I	Right/left inversion discrimination signal input (High: Normal, Low: Reverse)	H
13	SLFR	I	1H/1F inversion switching (High: 1H, Low: 1F)	H
14	TST1	I	Test pin (Not connected or High.)	H
15	V <sub>SS</sub>	—	GND	—
16	HD2IN	I	HD2 input (for NTSC/PAL separate-sync)	—
17	VD2IN	I	VD2 input (for NTSC/PAL separate-sync)	—
18	SLSY	I	SYNC input switching (High: CSYNC, Low: HD2IN and VD2IN)	H
19	SLMNB	I	Switches mode (High: Nothing, Low: 400 → 480 line conversion)	H
20	TST2	I	Test pin (Not connected or High.)	H
21	TST3	I	Test pin (Connect to GND.)	H
22	N.C.	—	N.C.	—
23	TST4	—	Test pin (Not connected or High.)	—
24	TST5	—	Test pin (Not connected or High.)	—
25	TST6	—	Test pin (Not connected or High.)	—
26	TST7	—	Test pin (Not connected.)	—
27	TST8	—	Test pin (Connect to GND.)	—
28	V <sub>DD</sub>	—	Power supply	—
29	V <sub>SS</sub>	—	GND	—
30	EXT-CKI	I	External clock input	—
31	PEO	I/O	Loop filter integrator output	—
32	PWM	I	Loop filter integrator input	—
33	CKO	I/O	Oscillation cell output (NTSC/PAL)	—
34	CKI	I	Oscillation cell input (NTSC/PAL)	—
35	RPD	O	Phase comparator output (NTSC/PAL)	—
36	SLCKI	I	Clock input selection (High: CKI, Low: EXT-CKI) (NTSC/PAL mode only)	H
37	TST9	I	Test pin (Not connected or High.)	H
38	FPD	O	Phase comparator output (NTSC/PAL)	—

Pin No.	Symbol	I/O	Description	Input pin for open status
39	TC	I/O	FPD pin pulse width adjustment	—
40	V <sub>SS</sub>	—	GND	—
41	SCK	I	Serial interface clock input	H
42	V <sub>SS</sub>	—	GND	—
43	SI	I	Serial interface data input	L
44	CS	I	Serial interface chip select	H
45	V <sub>SS</sub>	—	GND	—
46	V <sub>SS</sub>	—	GND	—
47	V <sub>SS</sub>	—	GND	—
48	V <sub>SS</sub>	—	GND	—
49	V <sub>SS</sub>	—	GND	—
50	TST10	I	Test pin (Not connected or High.)	H
51	V <sub>SS</sub>	—	GND	—
52	V <sub>SS</sub>	—	GND	—
53	V <sub>DD</sub>	—	Power supply	—
54	V <sub>SS</sub>	—	GND	—
55	PO0	O	Serial I/O data output	—
56	PO1	O	Serial I/O data output	—
57	PO2	O	Serial I/O data output	—
58	PO3	O	Serial I/O data output	—
59	PO4	O	Serial I/O data output	—
60	PO5	O	Serial I/O data output	—
61	PO6	O	Serial I/O data output	—
62	PO7	O	Serial I/O data output	—
63	PO8	O	Serial I/O data output	—
64	PO9	O	Serial I/O data output	—
65	V <sub>SS</sub>	—	GND	—
66	PO10	O	Serial I/O data output	—
67	PO11	O	Serial I/O data output	—
68	HDN	O	Phase comparator output (positive polarity)	—
69	XHDN	O	Phase comparator output (negative polarity)	—
70	FLD	O	Field discrimination signal output	—
71	DWM	O	Up/down inversion discrimination signal output	—
72	VDO	O	VD pulse output (positive polarity)	—
73	HDO	O	HD pulse output (positive polarity)	—
74	XHDO	O	HD pulse output (negative polarity)	—
75	PRG	O	Precharge signal pulse (positive polarity)	—
76	XCLP1	O	Pedestal clamp pulse 1	—
77	XCLP2	O	Pedestal clamp pulse 2	—
78	V <sub>DD</sub>	—	Power supply	—
79	V <sub>SS</sub>	—	GND	—
80	FRP	O	AC drive inversion timing output	—
81	XFRP	O	AC drive inversion timing output	—
82	RGT	O	Right/left inversion discrimination signal output	—

Pin No.	Symbol	I/O	Description	Input pin for open status
83	XRGT	O	Right/left inversion discrimination signal output	—
84	HST	O	H start pulse output (positive polarity)	—
85	HCK1	O	H clock pulse 1 output	—
86	HCK2	O	H clock pulse 2 output	—
87	CLR	O	CLR pin output	—
88	ENB	O	ENB pin output	—
89	INT	O	INT pin output	—
90	V <sub>SS</sub>	O	GND	—
91	PCG	O	PCG pin output (positive polarity)	—
92	VCK	O	V clock pulse output	—
93	VST1	O	V start pulse output	—
94	SH1	O	Sample-and-hold pulse 1 (positive polarity)	—
95	SH2	O	Sample-and-hold pulse 2 (positive polarity)	—
96	SH3	O	Sample-and-hold pulse 3 (positive polarity)	—
97	SH4	O	Sample-and-hold pulse 4 (positive polarity)	—
98	SH5	O	Sample-and-hold pulse 5 (positive polarity)	—
99	SH6	O	Sample-and-hold pulse 6 (positive polarity)	—
100	SH7	O	Sample-and-hold pulse 7 (positive polarity)	—

## Electrical Characteristics

### 1. DC characteristics

(Temperature = 25 °C, V<sub>SS</sub> = 0 V)

Item	Symbol	Conditions	Min.	Typ.	Max.	Unit	Applicable pins
Supply voltage	V <sub>DD</sub>		4.5	5.0	5.5	V	
Input voltage 1	VIH1	CMOS input cell	0.7 V <sub>DD</sub>			V	Input pins other than those noted below
	VIL1				0.3 V <sub>DD</sub>		
Input voltage 2	VIH2	CMOS Schmitt trigger input cell	0.8 V <sub>DD</sub>			V	HDnIN, VDnIN, CSYNC, CKI, PWM, TC, PEO, CKO, SI, SCK, CS
	VIL2				0.2 V <sub>DD</sub>		
	VT+ -VT+			0.6			
Output voltage 1	VOH	IOH=-2 mA	V <sub>DD</sub> -0.8			V	Output pins other than those noted below
	VOL	IOL=4 mA			0.4		
Output voltage 2	VOH	IOH=-4 mA	V <sub>DD</sub> -0.8			V	VCK
	VOL	IOL=8 mA			0.4		
Output voltage 3	VOH	IOH=-6 mA	V <sub>DD</sub> -0.8			V	HCKn, SHn, HST
	VOL	IOL=12 mA			0.4		
Output voltage 4	VOH	IOH=-3 mA	V <sub>DD</sub> /2			V	CKO, PEO
	VOL	IOL=3 mA			V <sub>DD</sub> /2		
Input leak current	IIL	Pull-up resistor connected	-40	-100	-240	μA	*1
	IIH	Pull-down resistor connected	40	100	240		SI
Output leak current	ILZ	High impedance status	-40		40	μA	RPD, FPD
Current consumption	IDD	fclk=31 MHz V <sub>DD</sub> =5.0 V		55		mA	At no load

\*1 Input pins with pull-up resistors

HPOL, VPOL, XCLR, PLNT, VGAV, SLDWN, SLRGT, SLFR, TST1, SLSY, TST2, TST3, SLCKI, TST9, SCK, CS

2. AC characteristics

( $V_{DD}=5.0\text{ V}\pm 0.5\text{ V}$ ,  $V_{SS}=0\text{ V}$ )

Item	Applicable pins	Symbol	Conditions	Min.	Typ.	Max.	Unit
Clock input cycle	EXT-CKI, CKI			25			ns
Cross-point time difference	HCK1, 2	$\Delta t$	CL=30 pF	-10		10	ns
Output rise delay	HCKn, SHn	tpr	CL=30 pF			20	ns
Output fall delay	HCKn, SHn	tpf	CL=30 pF			20	ns
Output rise delay	Other than HCKn and SHn	tpr	CL=30 pF			30	ns
Output fall delay	Other than HCKn and SHn	tpf	CL=30 pF			30	ns
HCK1, SH1 delay time difference	HCK1, SH1	dt1	CL=30 pF			10	ns
HCK2, SH1 delay time difference	HCK2, SH1	dt2	CL=30 pF			10	ns
HCK1 duty	HCK1	tH/tH+tL	CL=30 pF	48	50	52	%
HCK2 duty	HCK2	tH/tH+tL	CL=30 pF	48	50	52	%

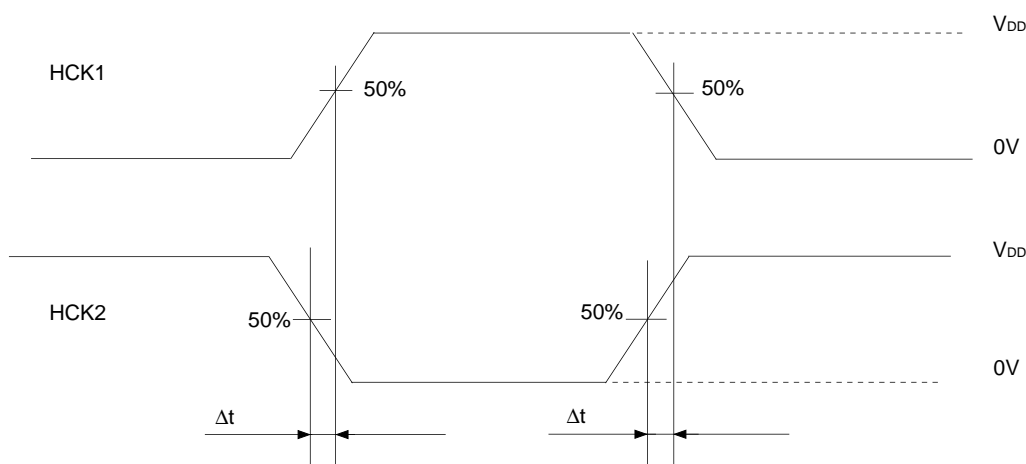
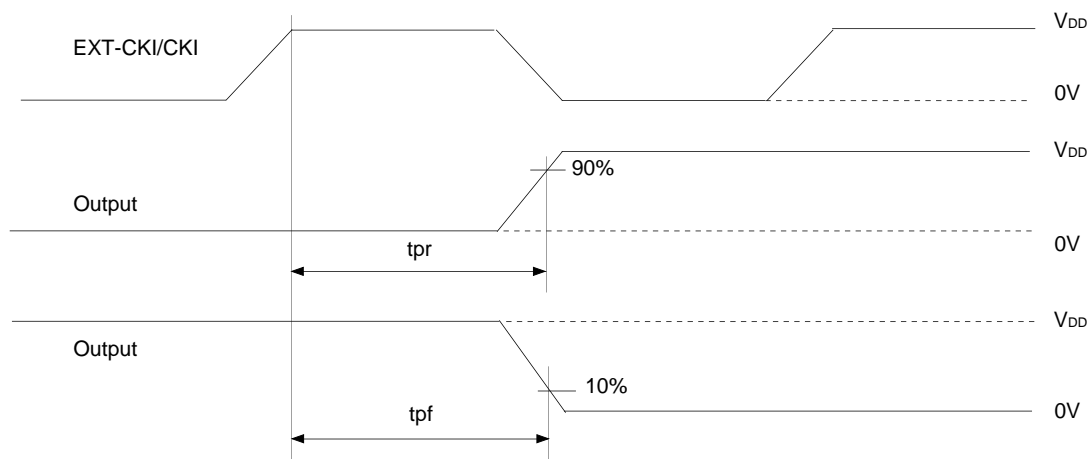

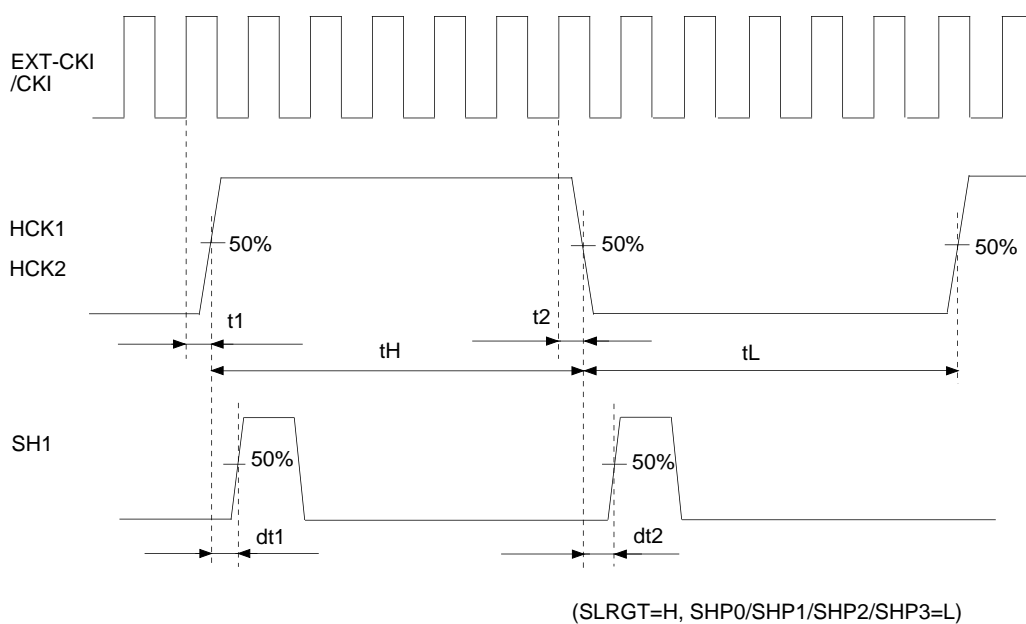

### 3. Serial interface block AC characteristics

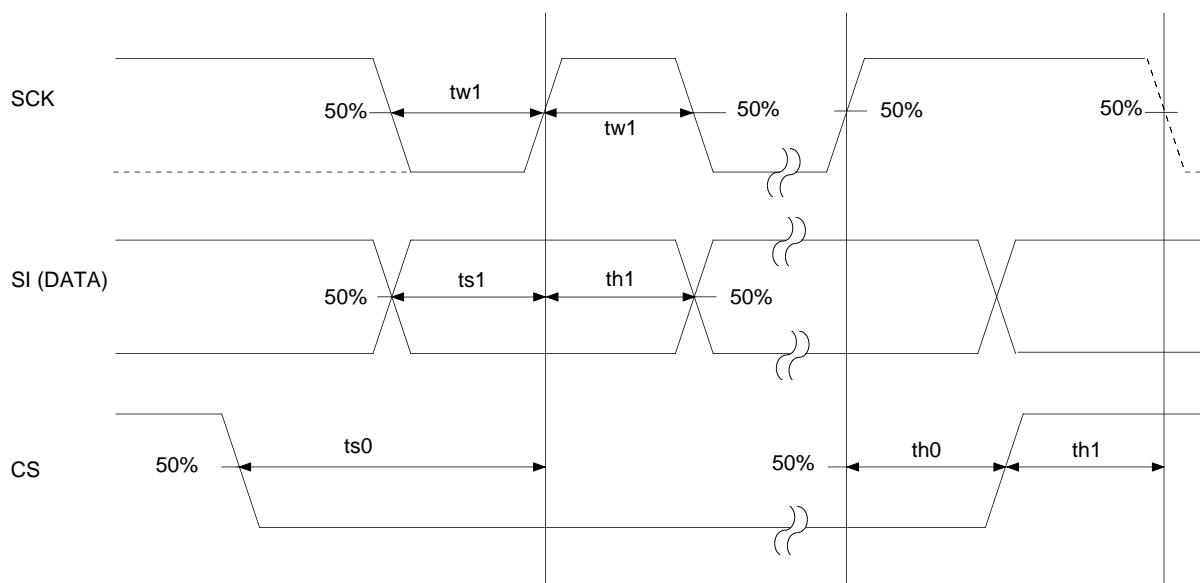

( $V_{DD}=5.0\text{ V}\pm 0.5\text{ V}$ ,  $V_{SS}=0\text{ V}$ ,  $T_{opr}=-20\text{ to }+75\text{ }^{\circ}\text{C}$ )

Symbol	Item	Min.	Max.
ts1	SI setup time with respect to rise of SCK	200 ns	
th1	SI hold time with respect to rise of SCK	200 ns	
tw1	SCK pulse width	200 ns	
ts0	CS setup time with respect to rise of SCK	200 ns	2tw1
th0	CS hold time with respect to rise of SCK	200 ns	2tw1
th1	SCK high-level hold time with respect to rise of CS	200 ns	

LCD Panel Structure

The structure of LCD panels (LCX012AL) driven by this IC is shown below.

The dot arrangement is a square arrangement, and the shaded region within the diagram is not displayed.

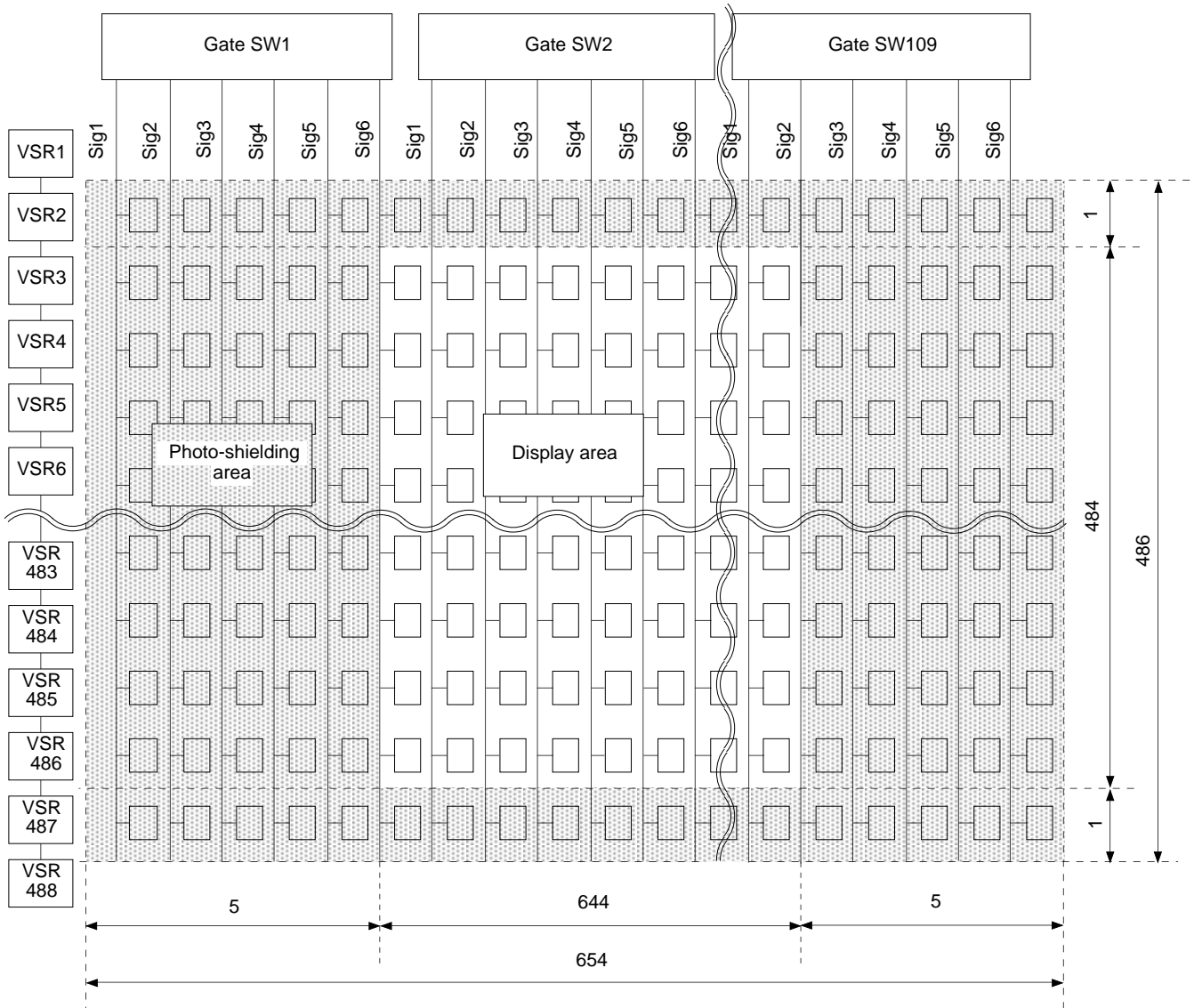

- The effective pixels are horizontal: 644 pixels and vertical: 484 pixels.
- The horizontal pixel start position is from Sig6 of the first-stage scanner. (Sig1 to Sig5 of the first-stage scanner are the photo-shielding area and are not displayed.)
- The vertical pixel start position is from the third-stage scanner.
- These relationships are the same even during up/down and/or right/left inversion. (The entire area within the panel is inverted.)

**Description of Operation**

• Sync input pins

The CXD2436Q has three types of sync input pins.

Pin No.	Symbol	SLSY setting	Application
1	HD1IN	—	SYNC input pins for VGA
2	VD1IN		
5	CSYNC	H	CSYNC input pin for NTSC/PAL
16	HD2IN	L	Separate SYNC input pins for NTSC/PAL
17	VD2IN		

• Clock input pins

The CXD2436Q has two clock input pin systems to support two types of PLL circuits.

1) When using EXT-CKI (using an external PLL IC)

The 1/N frequency divider output is output from the HDN and XHDN pins for the external PLL IC.

The used pins are shown in the following table. (SLCKI = Low)

Pin No.	Symbol	Application
30	EXT-CKI	Clock input
68	HDN	Phase comparison output (positive polarity)
69	XHDN	Phase comparison output (negative polarity)

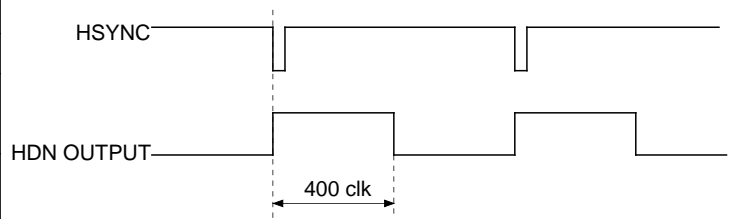

2) When using CKI

This system uses the built-in phase comparator and an externally attached VCO circuit (see the Application Circuit).

This system is used during AV mode (NTSC/PAL).

The used pins are shown in the following table. (Effective when SLCKI is set to High.)

Pin No.	Symbol	Application
31	PEO	Loop filter integrator output
32	PWM	Loop filter integrator input
33	CKO	Clock output (oscillation cell output)
34	CKI	Clock input (oscillation cell input)
35	RPD	Phase comparator output
38	FPD	Phase comparator output
39	TC	FPD pin pulse width adjustment

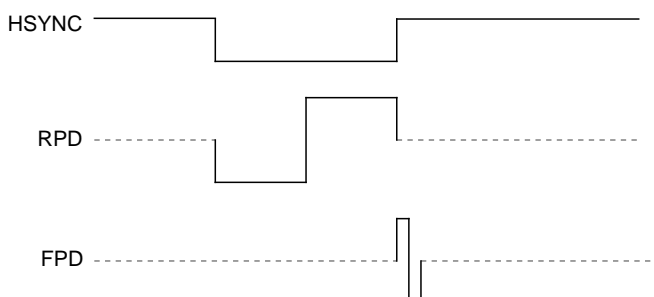

An outline of the output waveforms during PLL lock is shown in the figure to the left.

• **Connections supporting up/down and/or right/left inversion**

The CXD2436Q is designed for use with three-panel projectors, and has a system configuration which permits both normal and reverse scan. The RGT and XRGT output to the panel are switched according to the SLRGT input, and the DWN output is switched according to the SLDWN input in the same manner.

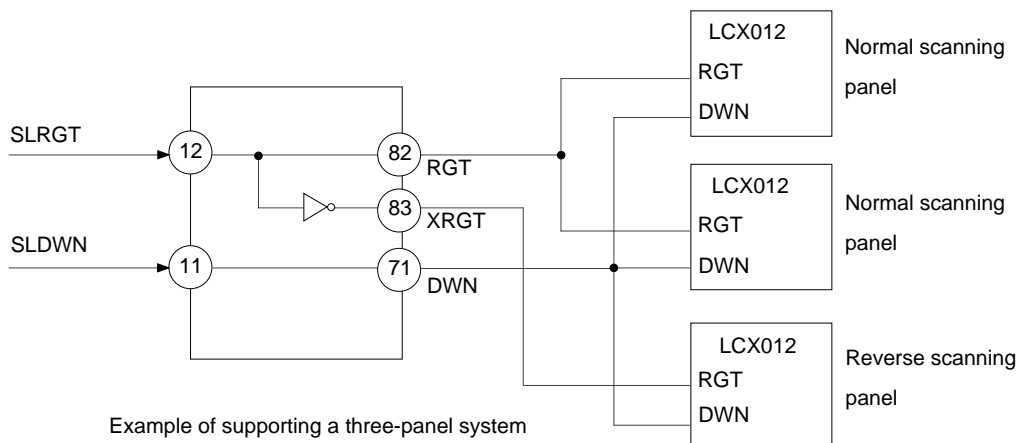

• **AC driving of LCD panels for no signal**

The following measures have been adopted to allow AC driving of LCD panels even when there is no signal.

- Horizontal direction pulse: The PLL is set to free running status. Therefore, the frequency of the horizontal direction pulse is dependent on the PLL free running frequency.
- Vertical direction pulse: The number of lines is counted by an internal counter and VST and FRP are output at a specified cycle.
- VST cycle for no signal
- Free running detection timing

NTSC	269H
PAL	321H
VGA	526H

NTSC	291H
PAL	339H
VGA	873H

Free running operates at the following cycles.

(No signal is judged if there is no VSYNC input for longer than the following periods.)

• **Description of the MODE selector switch**

- VGA/AV (NTSC/PAL) switching is performed with two pins.

VGAV	PLNT	MODE
H	H	VGA
H	L	VGA
L	H	NTSC
L	L	PAL

- The HD1IN, HD2IN, VD1IN, VD2IN and CSYNC input polarities are supported by two pins.

HPOL	VPOL	HD1IN HD2IN	VD1IN VD2IN	CSYNC
H	H	Positive polarity	Positive polarity	Positive polarity
H	L	Positive polarity	Negative polarity	—
L	H	Negative polarity	Positive polarity	—
L	L	Negative polarity	Negative polarity	Negative polarity

- XCLR (External clear)

Reset should be performed during startup in order to initialize the serial interface. Performing external clear sets all serial interface modes to Low.

- **Serial interface specifications**

The CXD2436Q can set and switch the driving mode with the serial interface.

Set the corresponding timing data for each VGA signal according to the format in the diagram below. Be sure to make the initial mode settings. (See the AC characteristics for detailed timing specifications.)

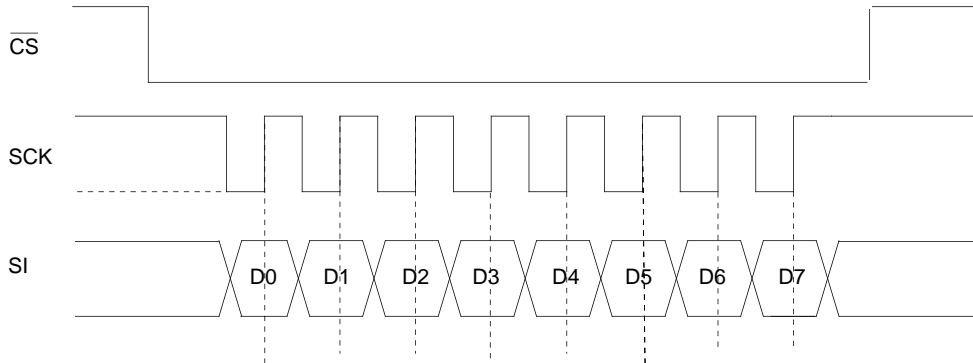

Fig. 1. Timing chart for the serial interface input block

**Note)** D0 to D7 internal transfer is completed by the  $\overline{CS}$  signal switching from a Low to High pulse. Therefore, the data should be transferred in 1-byte units with the  $\overline{CS}$  signal reset each time.

- **Description of mode switching settings using the serial interface**

The CXD2436Q can set the following six modes.

- (1) Frequency division ratio setting for the 1/N frequency divider of the master clock PLL circuit block.
- (2) H screen center adjustment. The center changes by one dot with LSB.
- (3) V screen center adjustment. The center changes by one line with LSB.
- (4) Sample-and-hold circuit phase adjustment. The phase changes by a half-dot with LSB.  
(See the Description of Sample-and-Hold Timing for details.)
- (5) Clamp pulse timing adjustment (4-way)
- (6) Data output (Serial data is held and output.)

Upper 4-bit address value D7 to D4	Lower 4-bit data				Functions
	D3	D2	D1	D0	
0H	PHP3	PHP2	PHP1	PHP0	PLL 1/N frequency divisions
1H	PHP7	PHP6	PHP5	PHP4	
2H	—	PHP10	PHP9	PHP8	
3H	HP3	HP2	HP1	HP0	H screen center adjustment
4H	—	HP6	HP5	HP4	
5H	VP3	VP2	VP1	VP0	V screen center adjustment
6H	—	VP6	VP5	VP4	
7H	SHP3	SHP2	SHP1	SHP0	S/H timing
8H	—	—	CLPP1	CLPP0	Clamp timing
9H	PO3	PO2	PO1	PO0	Data output
AH	PO7	PO6	PO5	PO4	
BH	PO11	PO10	PO9	PO8	

\* PHP0, HP0, VP0, SHP0, CLPP0

• **PLL 1/N frequency division ratio setting**

For the frequency division ratio setting during VGA mode, set the value of the number of dots for the horizontal period –1 in PHP0-10.

(Example) When the horizontal period is set to 800 dots

PHP setting value = 800-1 → 799 (01100011111 LSB)

PHP	10	9	8	7	6	5	4	3	2	1	0
	0	1	1	0	0	0	1	1	1	1	1

Set the value of the number of dots fixed to 816 during NTSC/PAL.

PHP setting value = 816-1 → 815 (01100101111 LSB)

PHP	10	9	8	7	6	5	4	3	2	1	0
	0	1	1	0	0	1	0	1	1	1	1

• **Horizontal position setting**

The horizontal display start position setting can be changed one dot at a time by the HP0 to 6 setting.

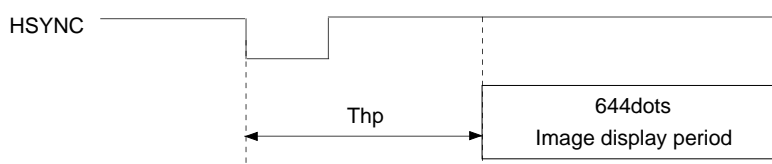

The maximum and minimum Thp values which can be set are shown in the following table.

HP	6	5	4	3	2	1	0	VGA	NTSC	PAL
Minimum value	1	1	1	1	1	1	1	110 dots	5.8 μs	5.8 μs
Maximum value	0	0	0	0	0	0	0	237 dots	15.7 μs	15.8 μs

• **Vertical position setting**

The vertical display start position setting can be changed one dot at a time by the VP0 to 6 setting.

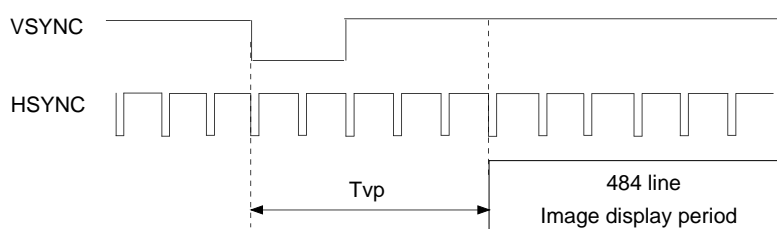

The maximum and minimum Tvp values which can be set are shown in the following table.

VP	6	5	4	3	2	1	0	VGA	NTSC	PAL
Minimum value	1	1	1	1	1	1	1	5 H	14 H	14 H
Maximum value	0	0	0	0	0	0	0	133 H	141 H	141 H

(This table shows the ODD field values for NTSC and PAL.)

• CLP pulse position setting

The XCLP pulse position can be changed to four different positions. Each of these positions is shown below.

The XCLP pulse is linked with the horizontal position setting, and is indicated with the HP (1000000 LSB) setting.

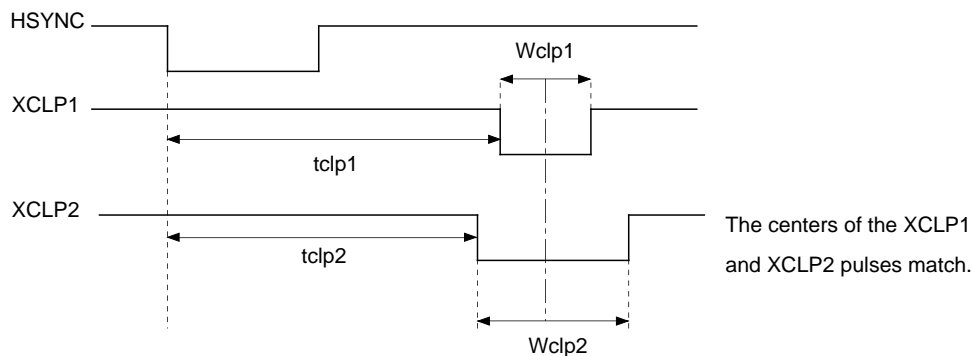

• VGA mode

CLPP1	CLPP0	tclp1	Wclp1	tclp2	Wclp2
0	0	74 dot	40 dot	61 dot	67 dot
0	1	81 dot	40 dot	68 dot	67 dot
1	0	88 dot	40 dot	75 dot	67 dot
1	1	95 dot	40 dot	82 dot	67 dot

• NTSC mode

CLPP1	CLPP0	tclp1	Wclp1	tclp2	Wclp2
0	0	4.83 μs	1.17 μs	4.36 μs	2.18 μs
0	1	5.30 μs	1.17 μs	4.83 μs	2.18 μs
1	0	5.76 μs	1.17 μs	5.30 μs	2.18 μs
1	1	6.23 μs	1.17 μs	5.76 μs	2.18 μs

• PAL mode

CLPP1	CLPP0	tclp1	Wclp1	tclp2	Wclp2
0	0	4.87 μs	1.18 μs	4.39 μs	2.20 μs
0	1	5.33 μs	1.18 μs	4.86 μs	2.20 μs
1	0	5.80 μs	1.18 μs	5.33 μs	2.20 μs
1	1	6.27 μs	1.18 μs	5.80 μs	2.20 μs

• Switching the SH pulse timing

The phase relationship between the sample-and-hold pulses and HCK can be switched in 12 different ways with SHP0, SHP1, SHP2 and SHP3.

(This timing generator has a 0.5 DOT OFFSET function in order to ensure the phase margin.)

In addition, the timing differs according to the scanning direction (right/left scan).

Right scanning pulse (RGT = H)

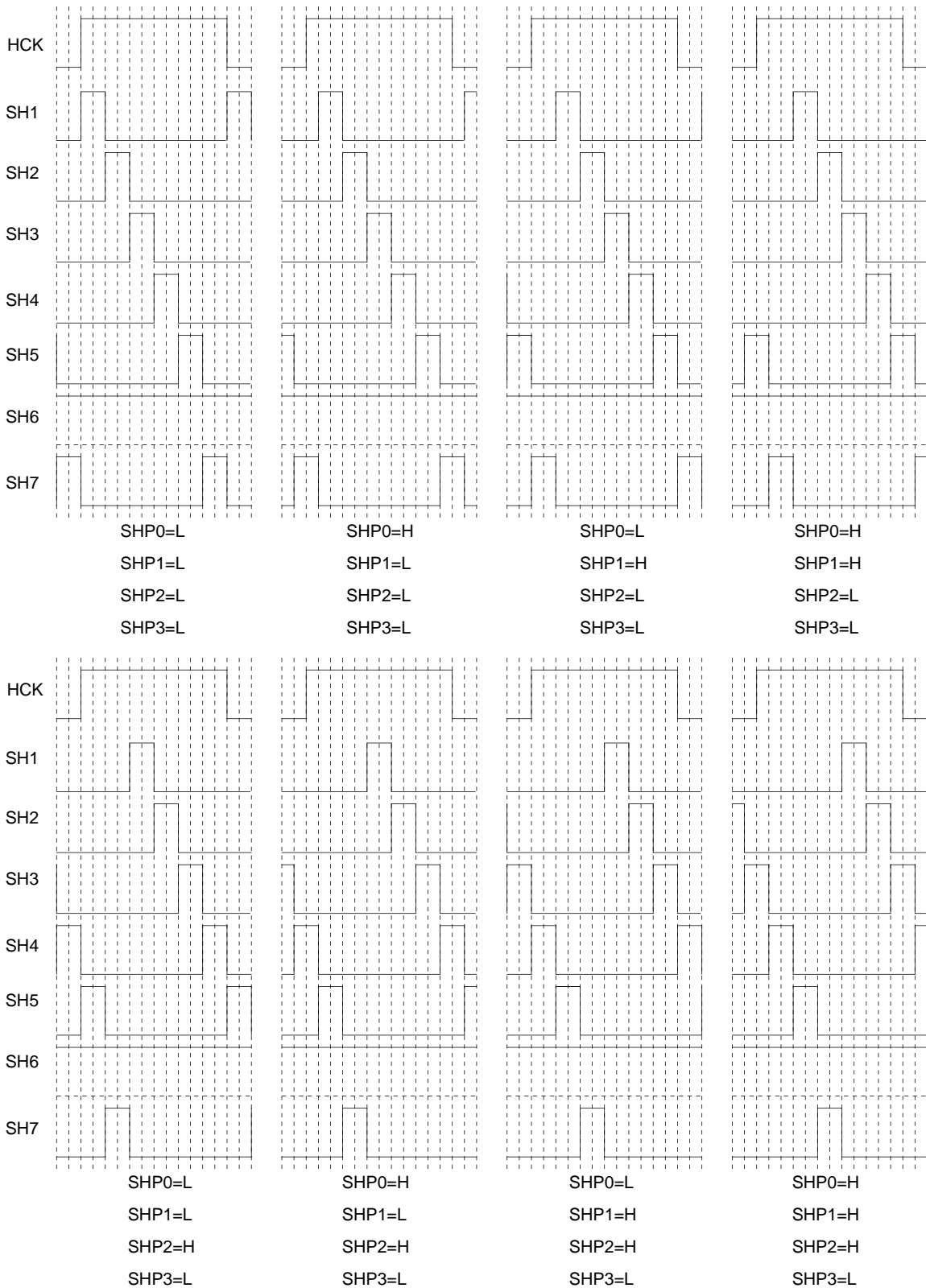

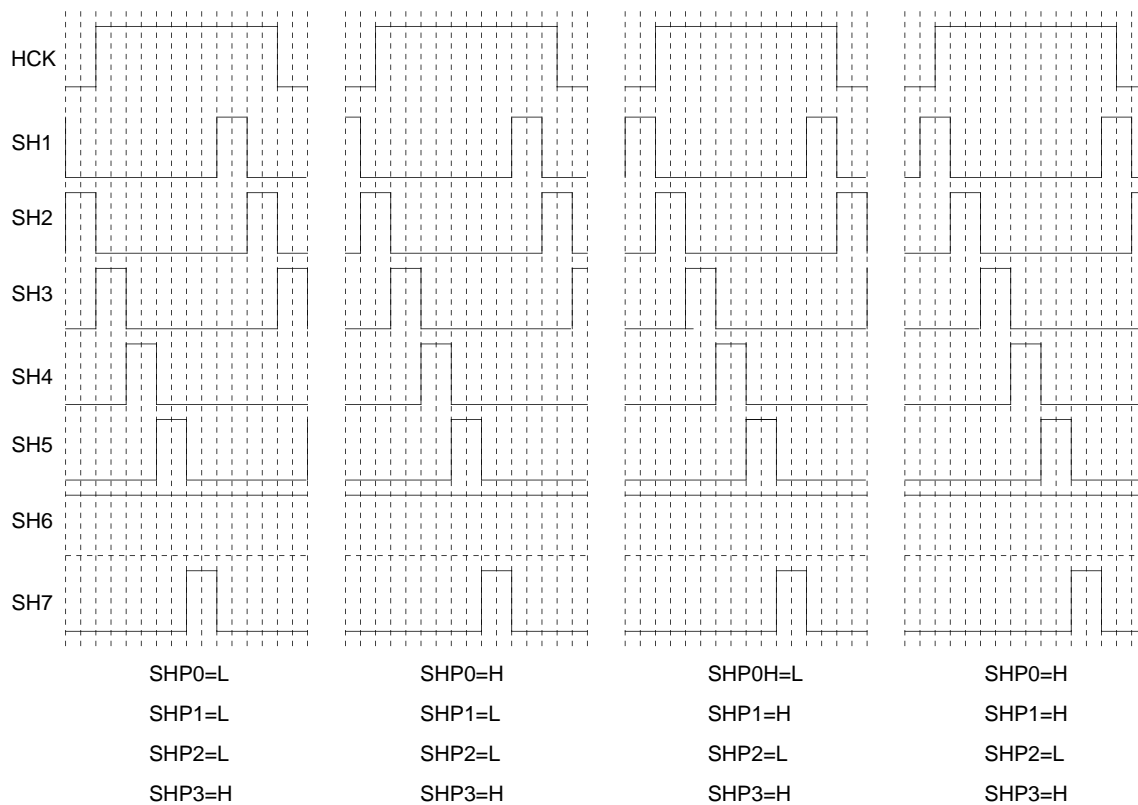

Left scanning pulse (RGT = L)

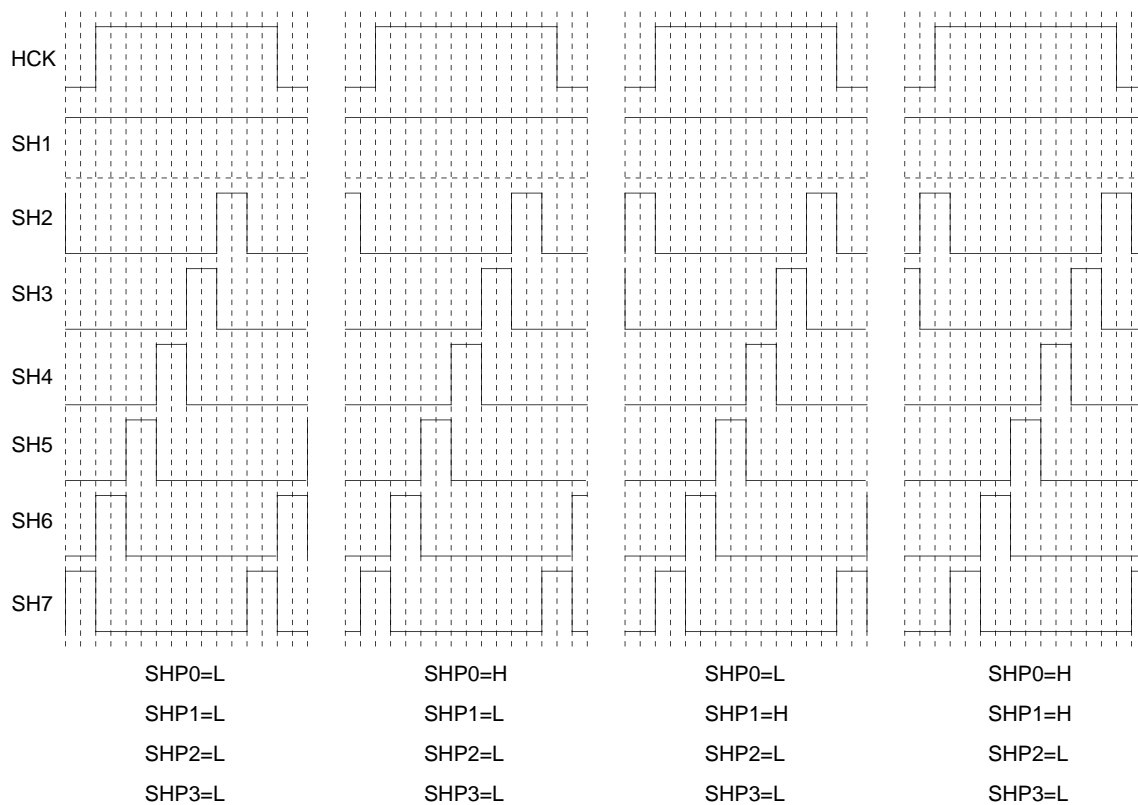

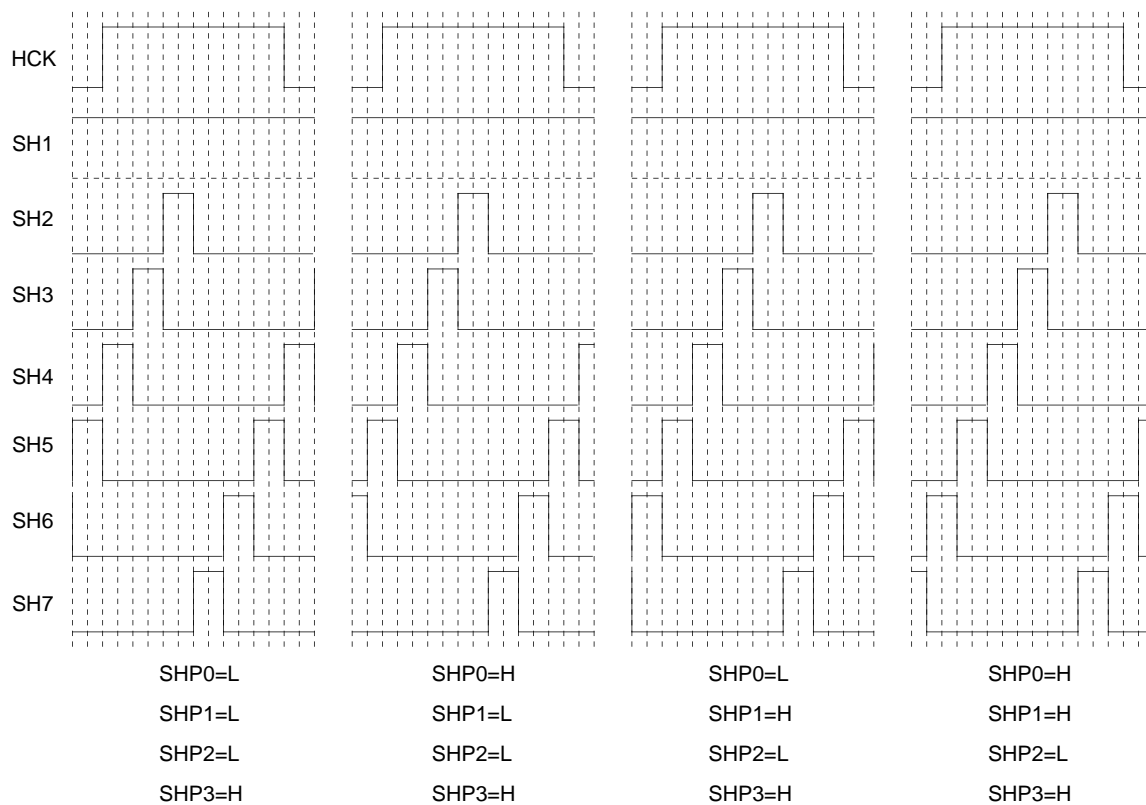
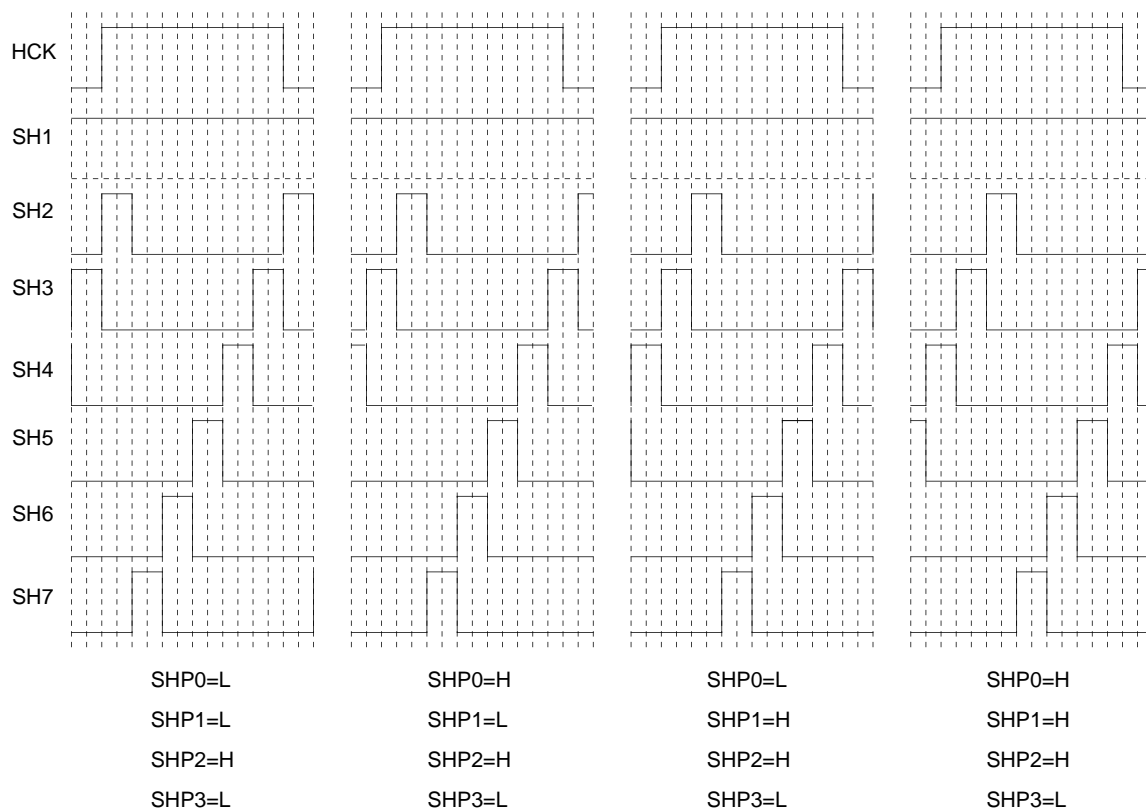

**Horizontal Direction Timing Chart (IBM-VGA 640 x 480)**

SLRGT: H (Normal scan)

HP: 1100001 LSB CLPP: 10 LSB SHP: 0000 LSB

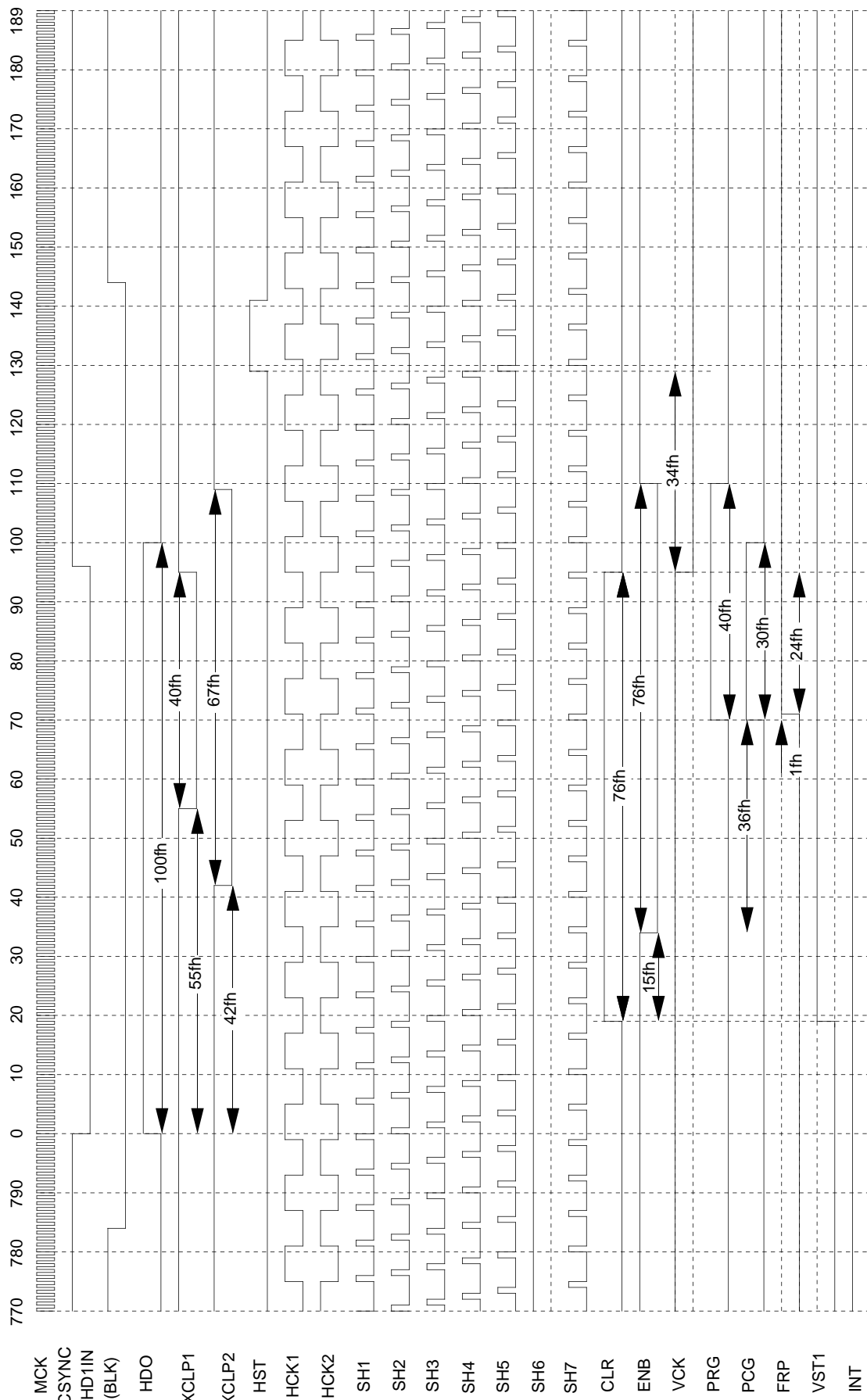

**Horizontal Direction Timing Chart (IBM-VGA 640 x 480)**

SLRGT: L (Reverse scan)

HP: 1100001 LSB CLPP: 10 LSB SHP: 0000 LSB

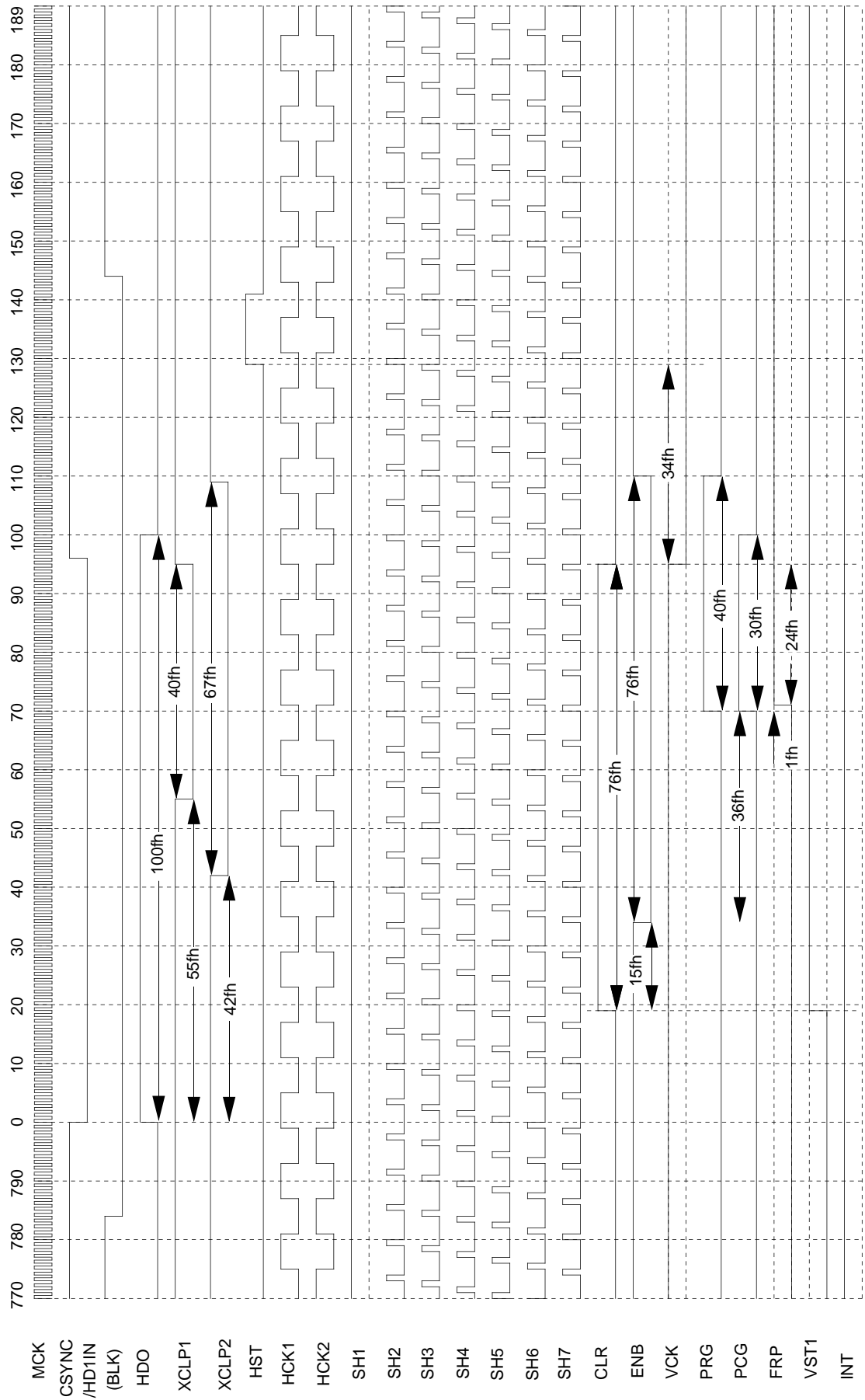

**Vertical Direction Timing Chart (IBM-VGA 640 x 480)**

SLDWN: H (Down scan)

VP: 1100100 LSB

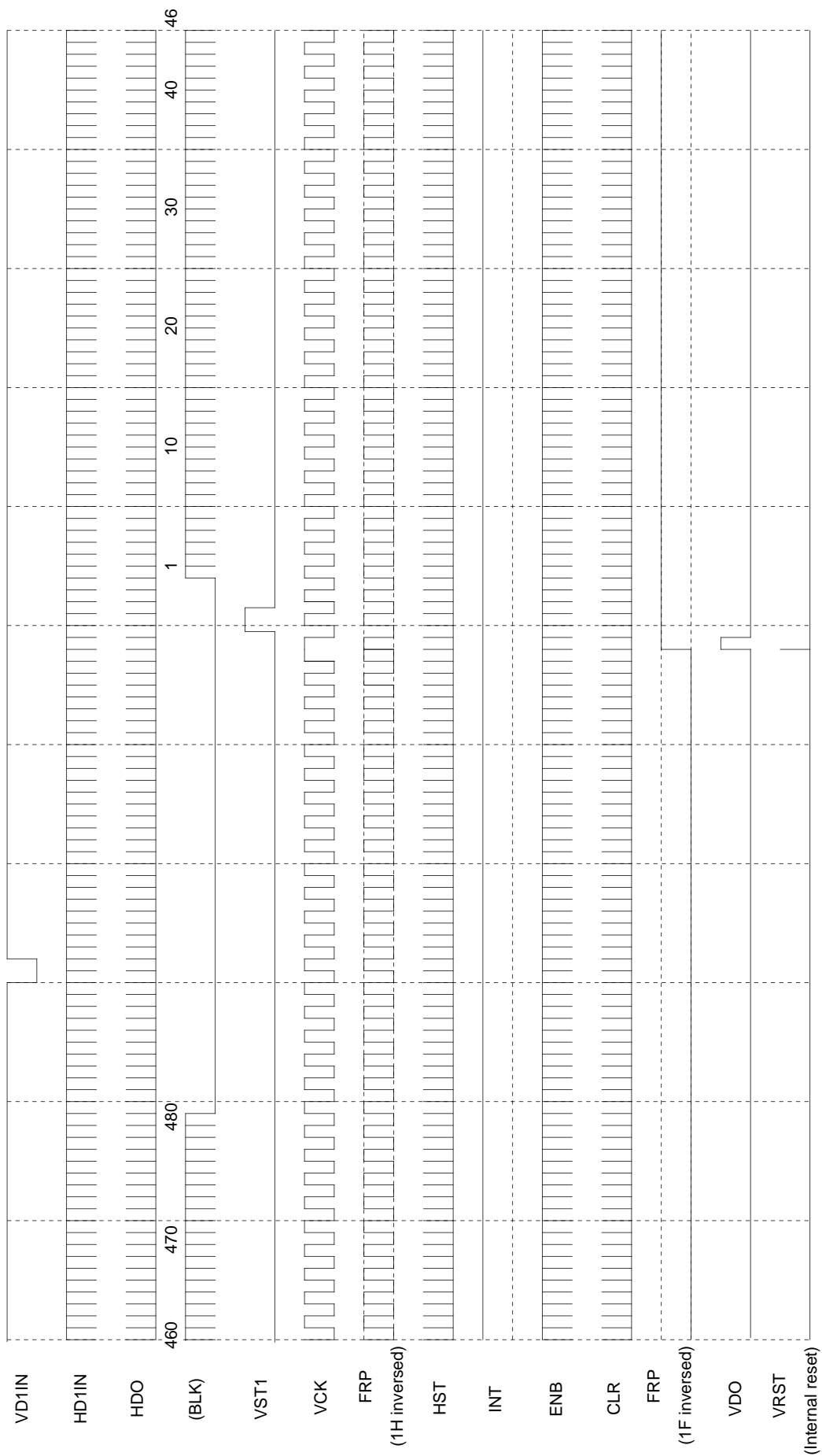

**Vertical Direction Timing Chart (IBM-VGA 640 x 480)**

SLDWN: L (Up scan)

VP: 1100100 LSB

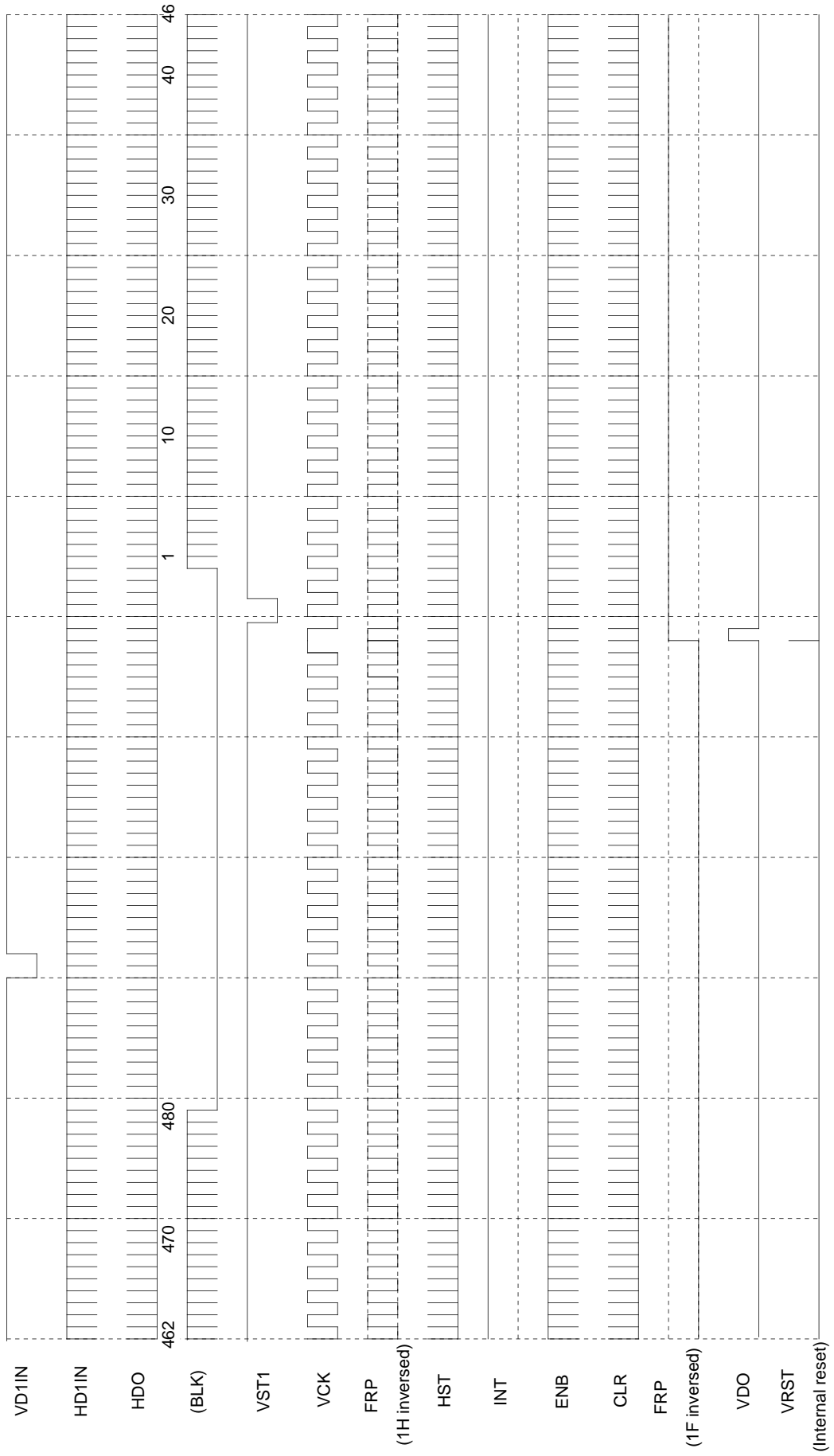

Horizontal Direction Timing Chart (NTSC)

MCK: 12.84 MHz (77.89 ns)  
 Loop Counter: 816 fh

RG T: H (Normal scan)  
 HP: 1000000 LSB CLPP: 10 LSB SHP: 0000 LSB

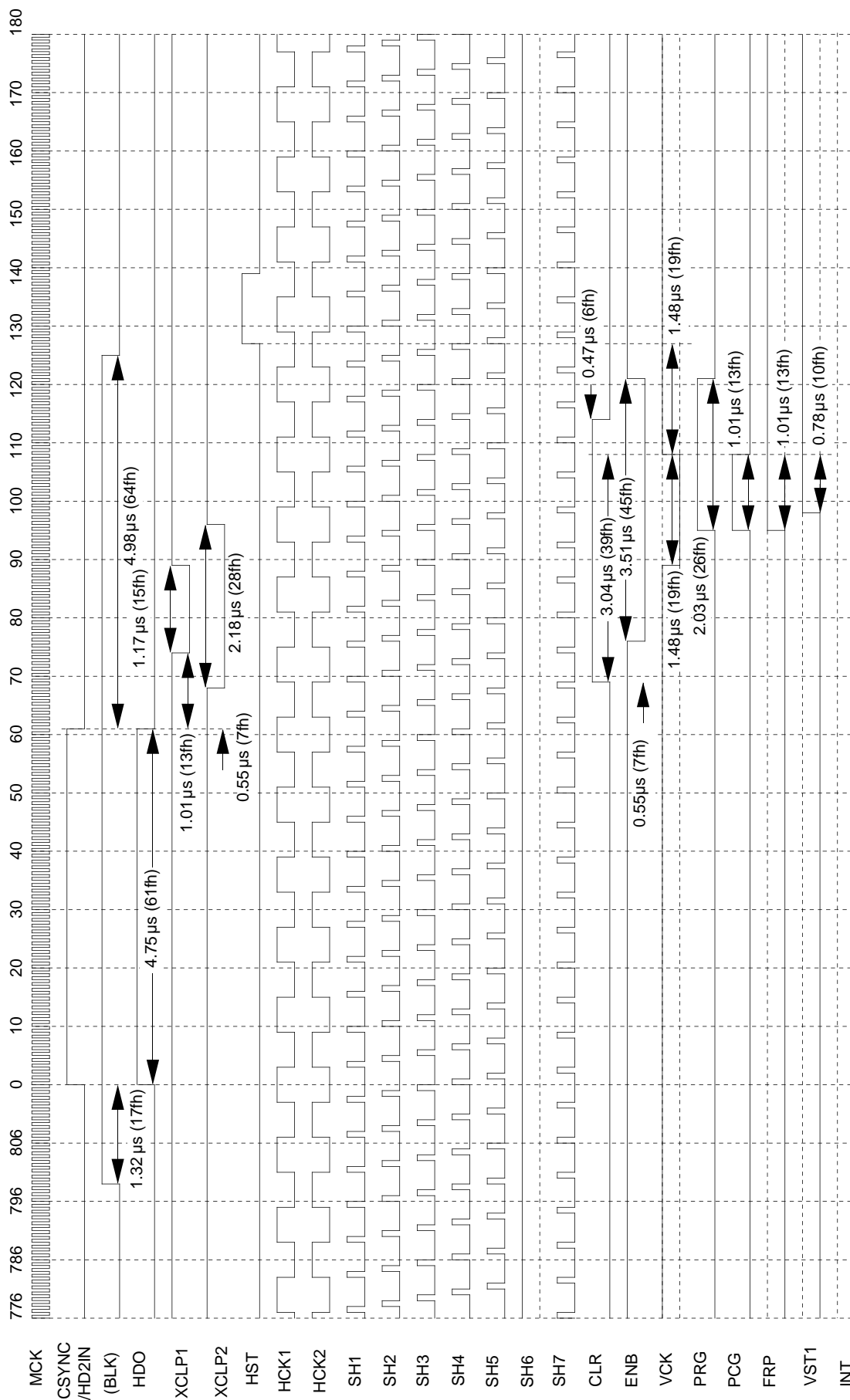

Horizontal Direction Timing Chart (NTSC)

RG T: L (Reverse scan) MCK: 12.84 MHz (77.89 ns)  
 HP: 1000000 LSB CLPP: 10 LSB SHP: 0000 LSB Loop Counter: 816 fh

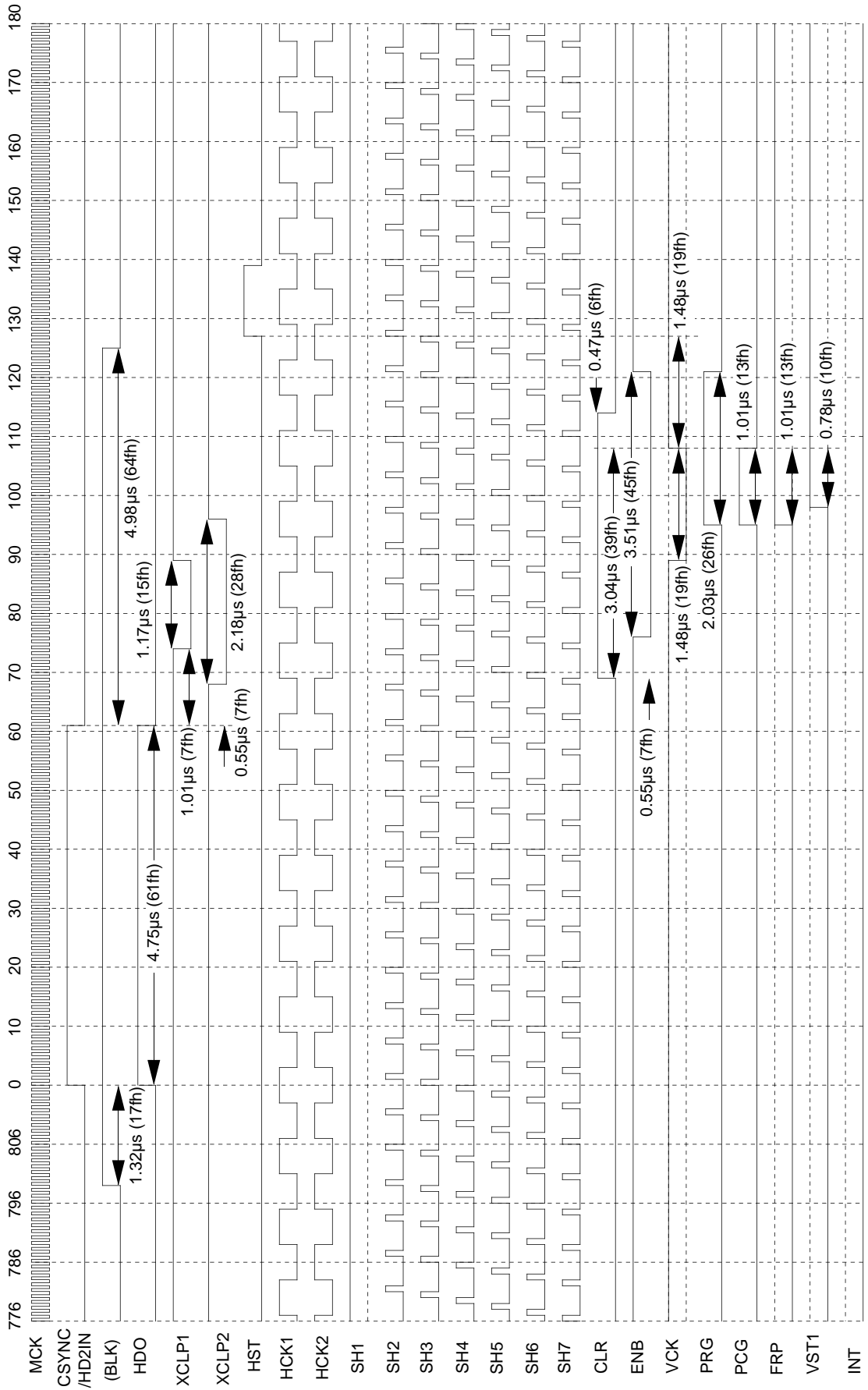

**Vertical Direction Timing Chart (NTSC, odd field)**

SLDWN: H (Down scan)

VP: 1111010 LSB

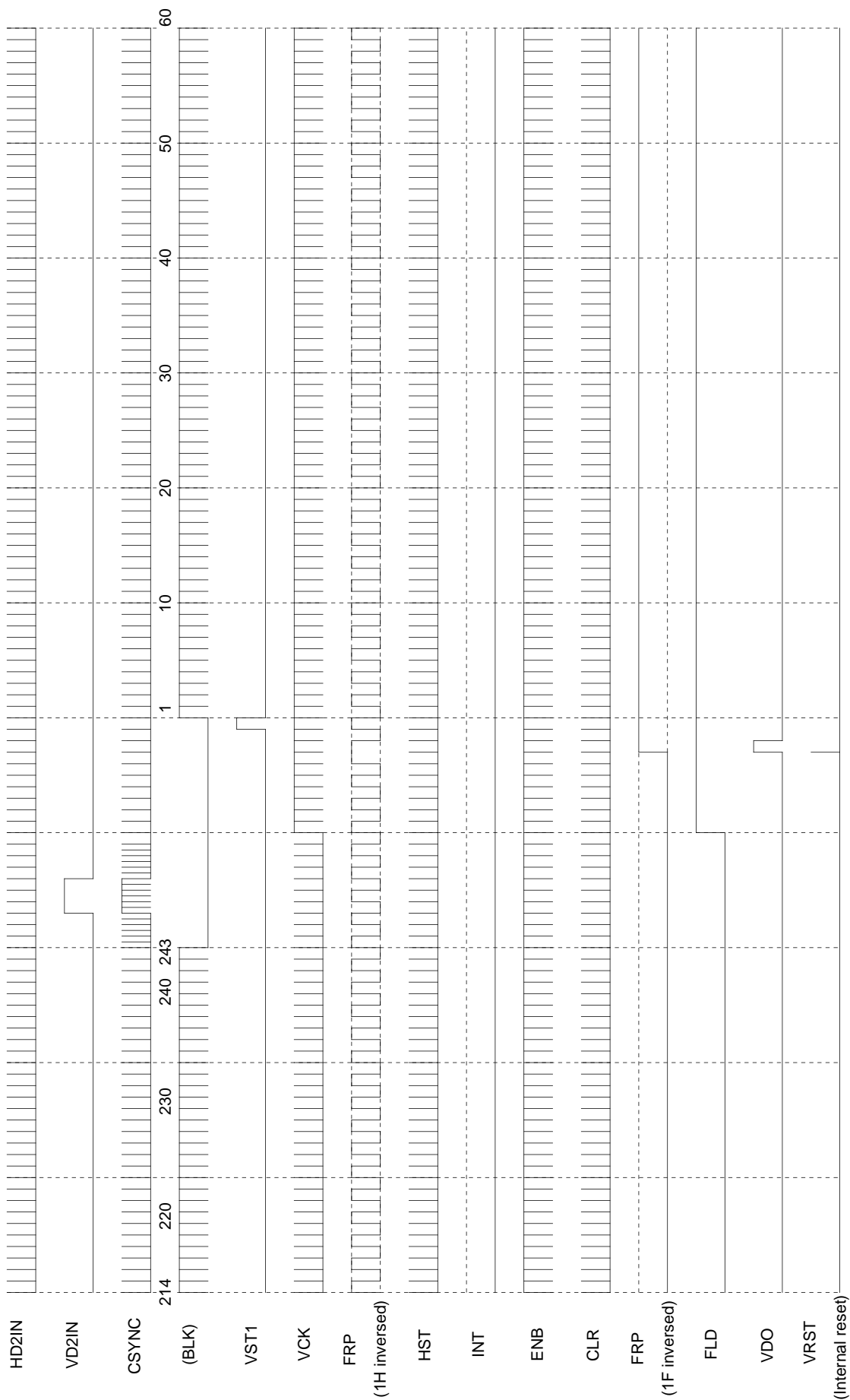

**Vertical Direction Timing Chart (NTSC, even field)**

SLDWN: H (Down scan)

VP: 1111010 LSB

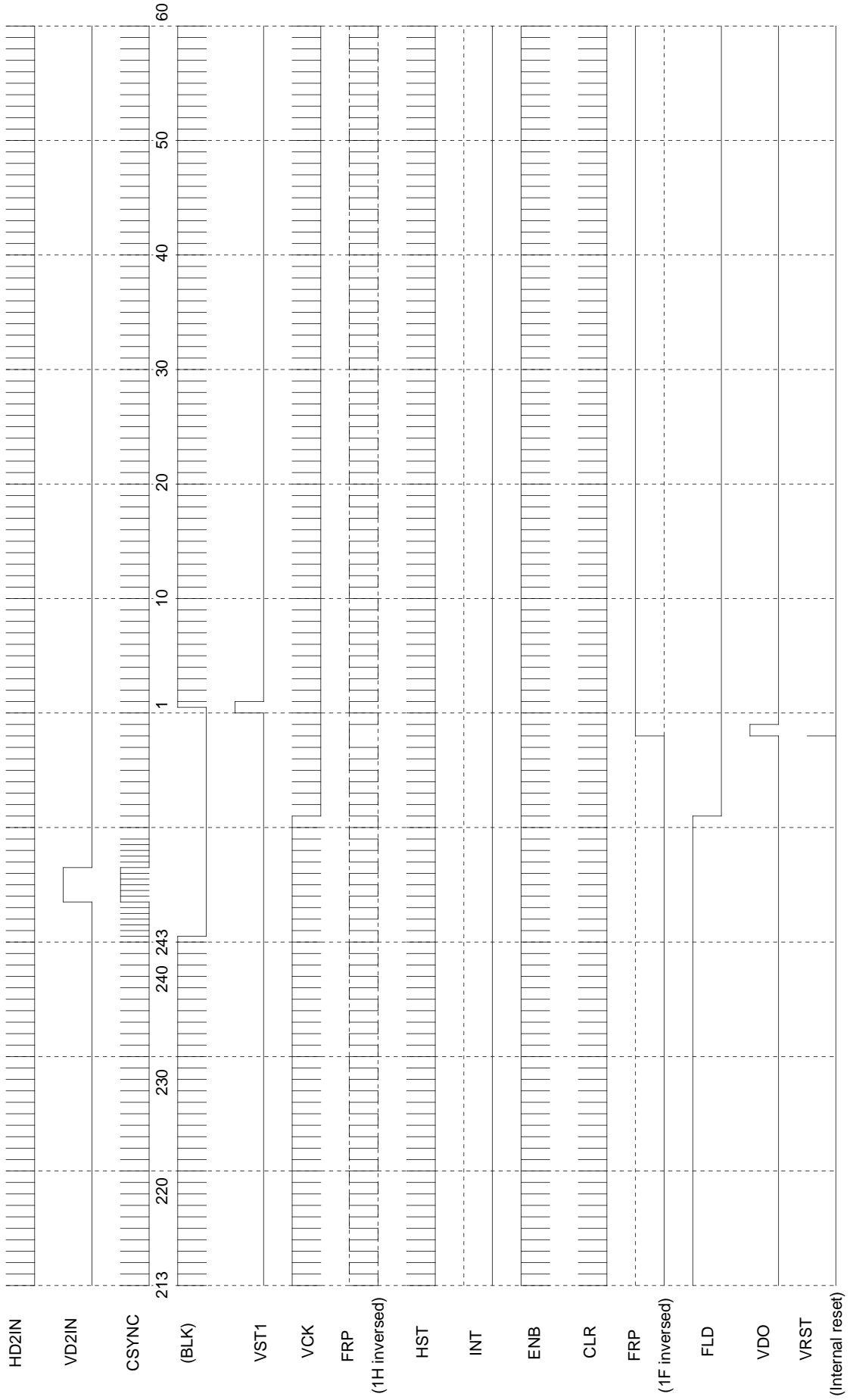

**Vertical Direction Timing Chart (NTSC, odd field)**

SLDWN: L (Up scan)

VP: 1111010 LSB

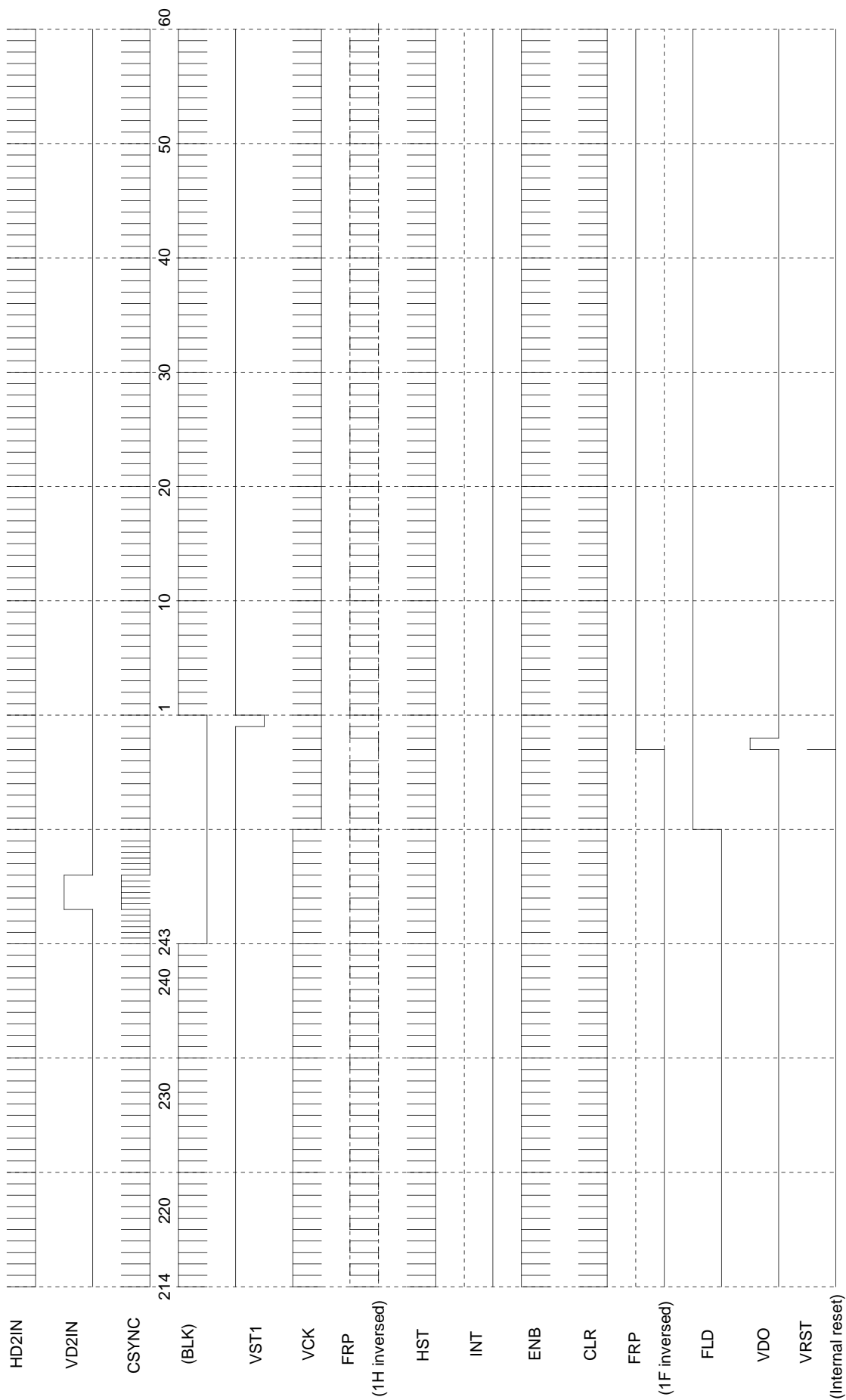

**Vertical Direction Timing Chart (NTSC, even field)**

SLDWN: L (Up scan)

VP: 1111010 LSB

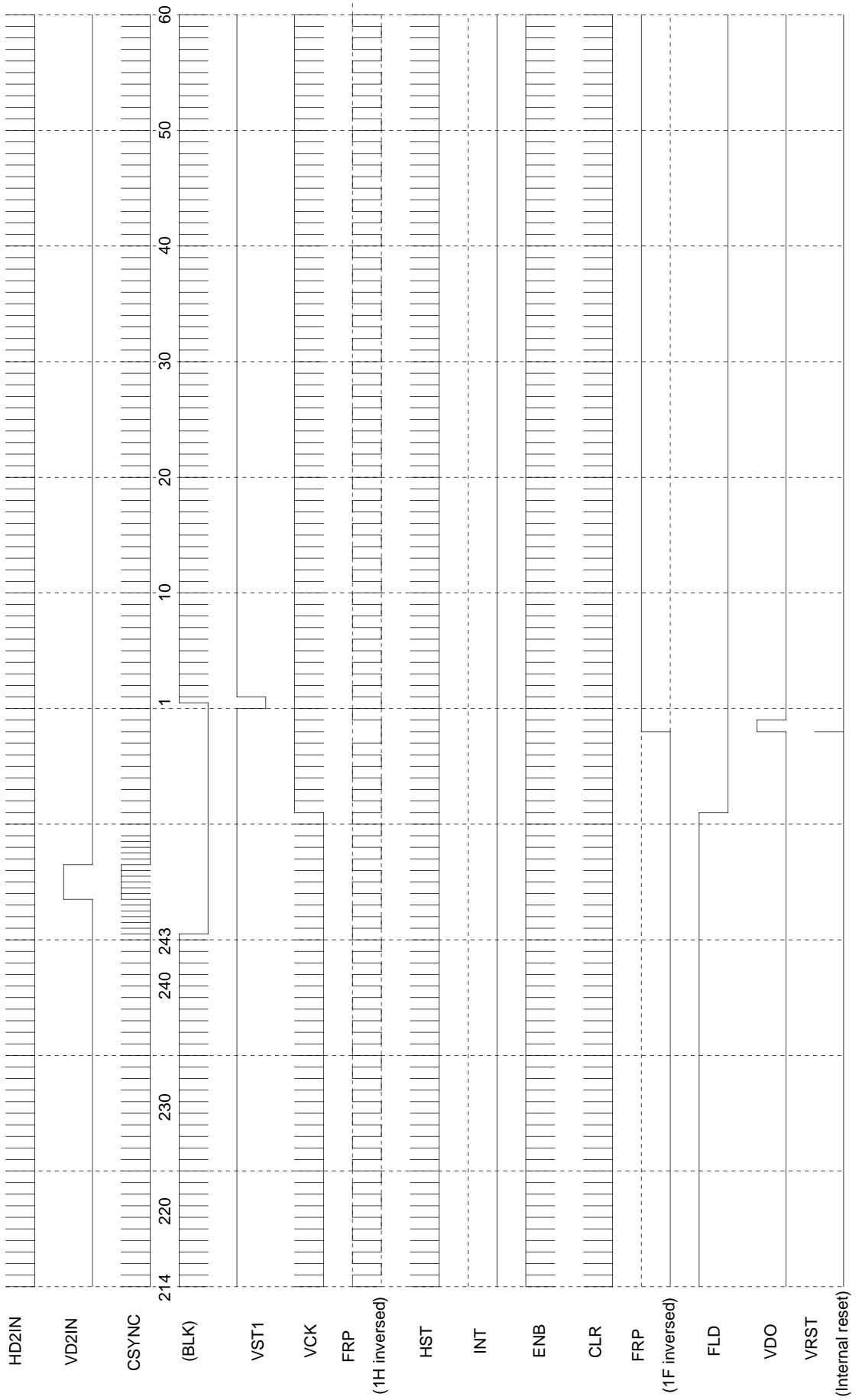

Horizontal Direction Timing Chart (PAL)

SLRGT: H (Normal scan)

HP: 1000000 LSB CLPP: 10 LSB SHP: 0000 LSB

MCK: 12.75 MHz (78.43 ns)

Loop Counter: 816 fh

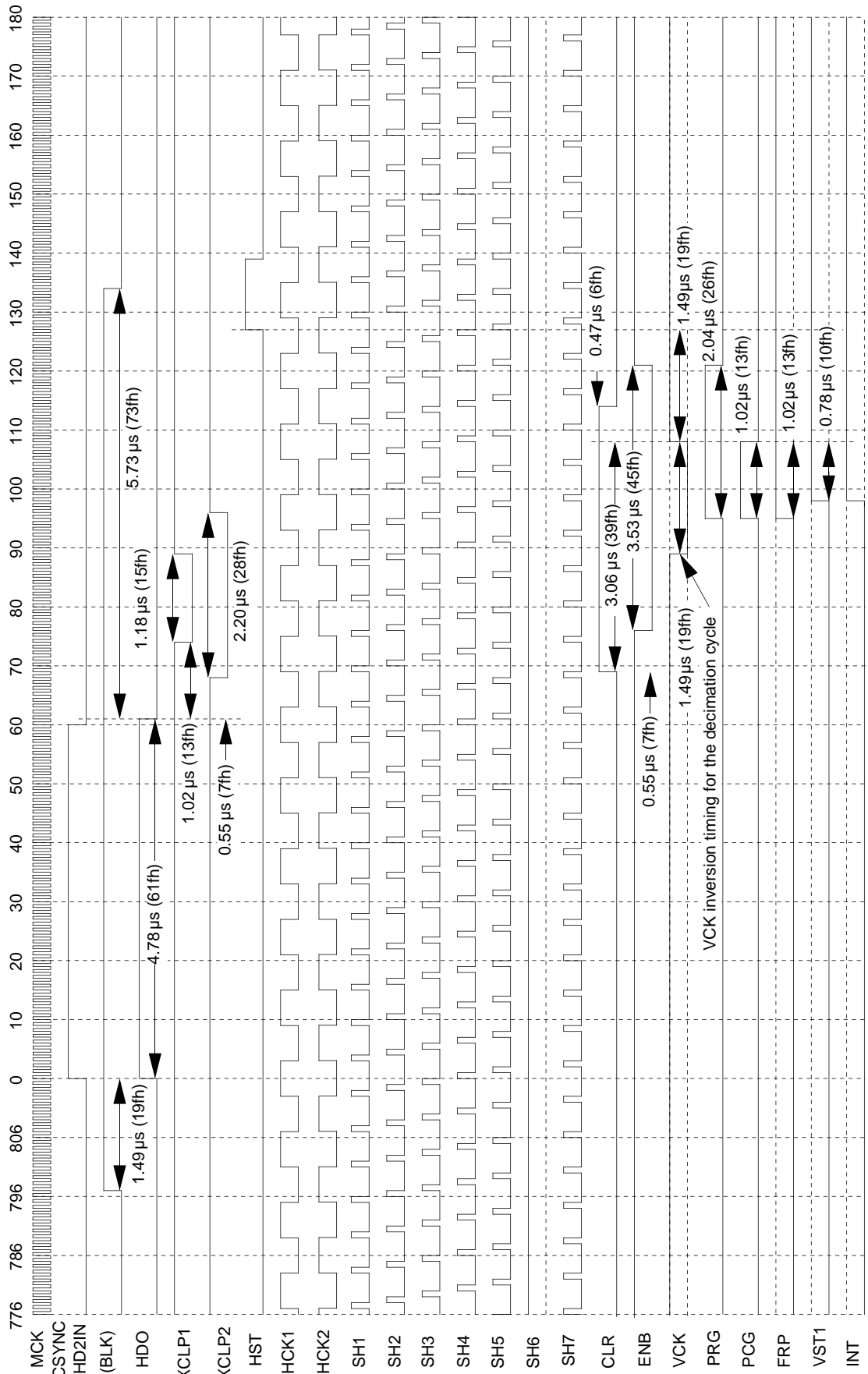

Horizontal Direction Timing Chart (PAL)

SLRGT: L (Reverse scan) MCK: 12.75 MHz (78.43 ns)  
 HP: 1000000 LSB CLPP: 10 LSB SHP: 0000 LSB Loop Counter: 816fh

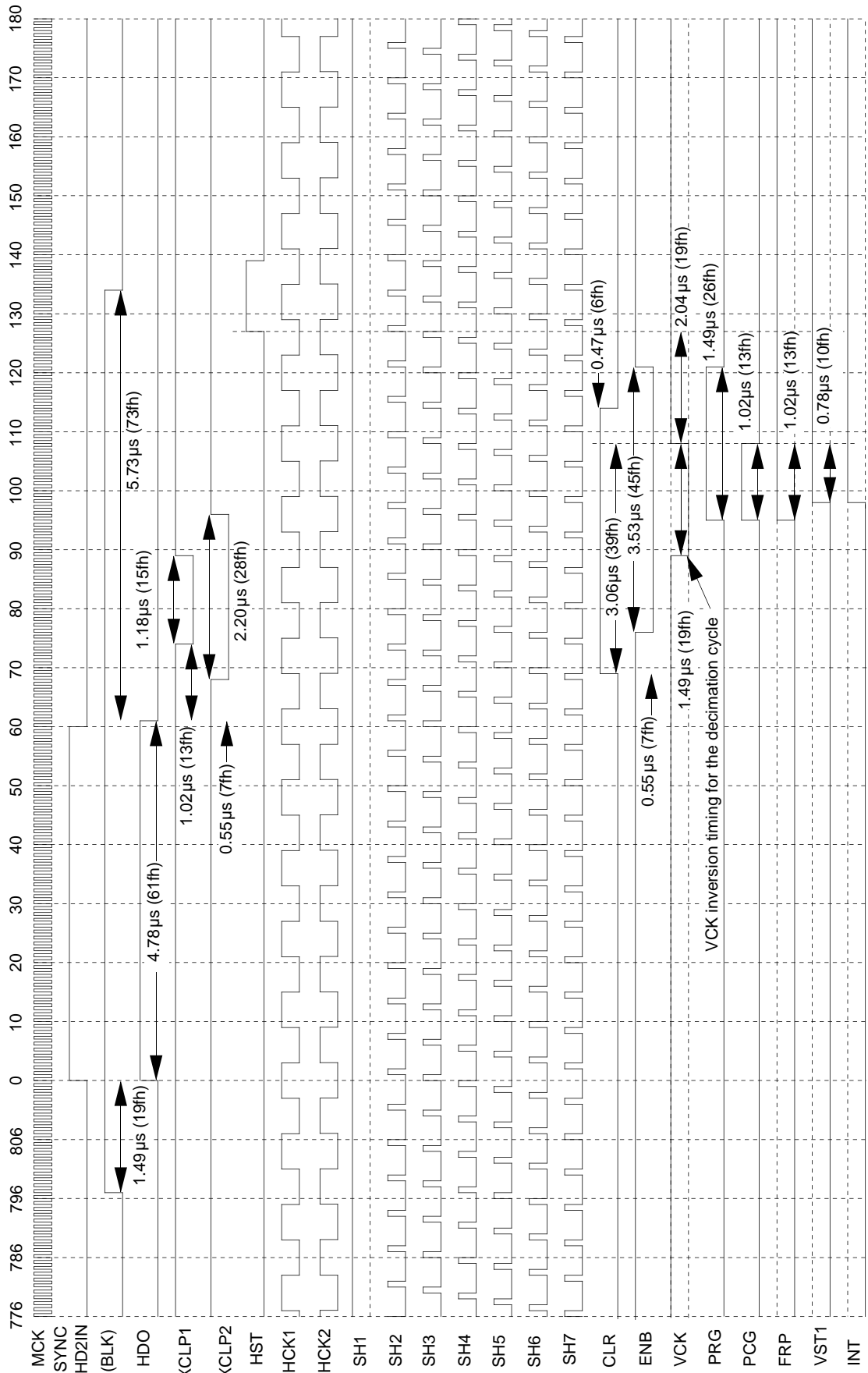

**Vertical Direction Timing Chart (PAL, odd field)**

SLDWN: H (Down scan)

VP: 1110010 LSB

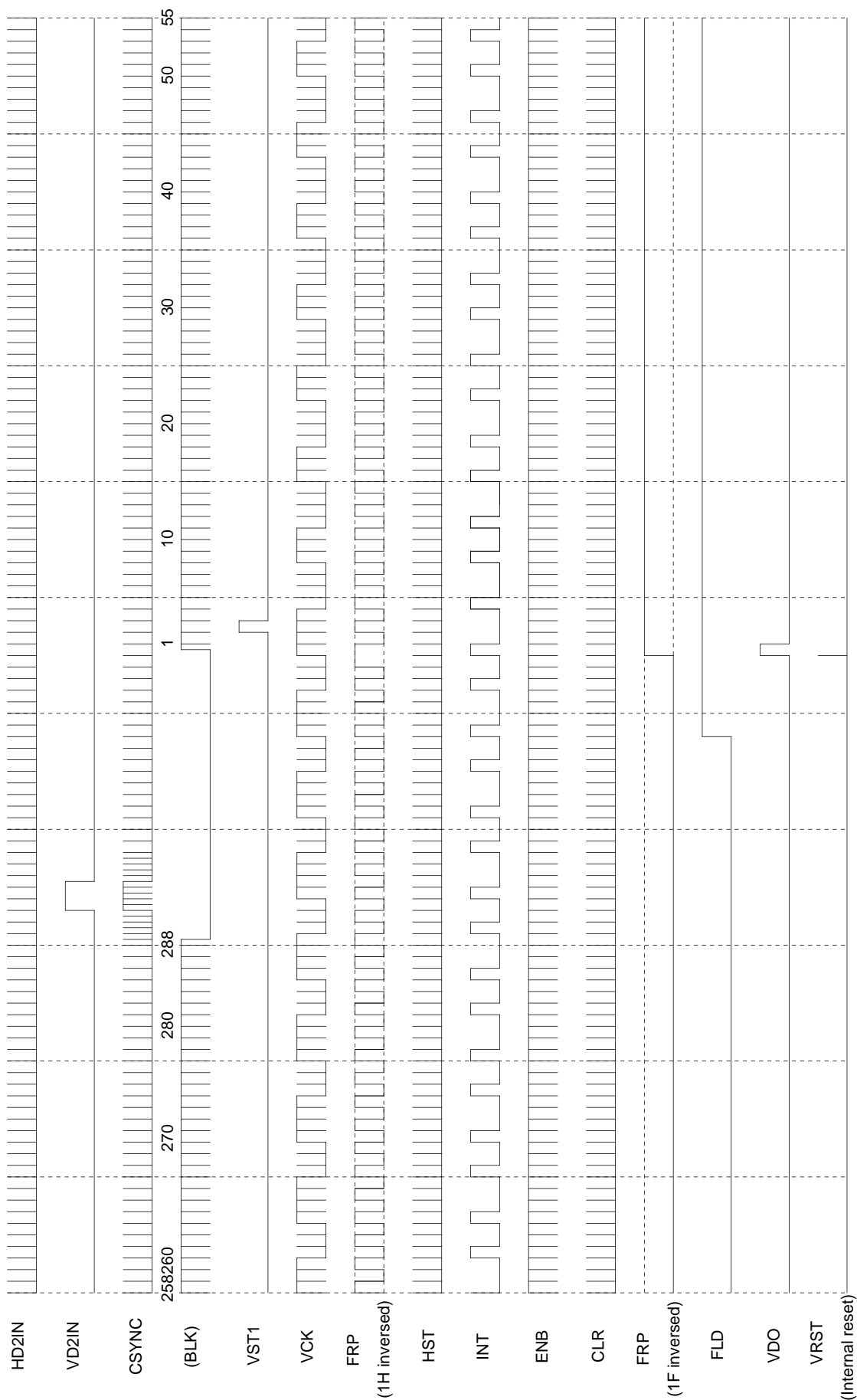

**Vertical Direction Timing Chart (PAL, even field)**

SLDWN: H (Down scan)

VP: 1110010 LSB

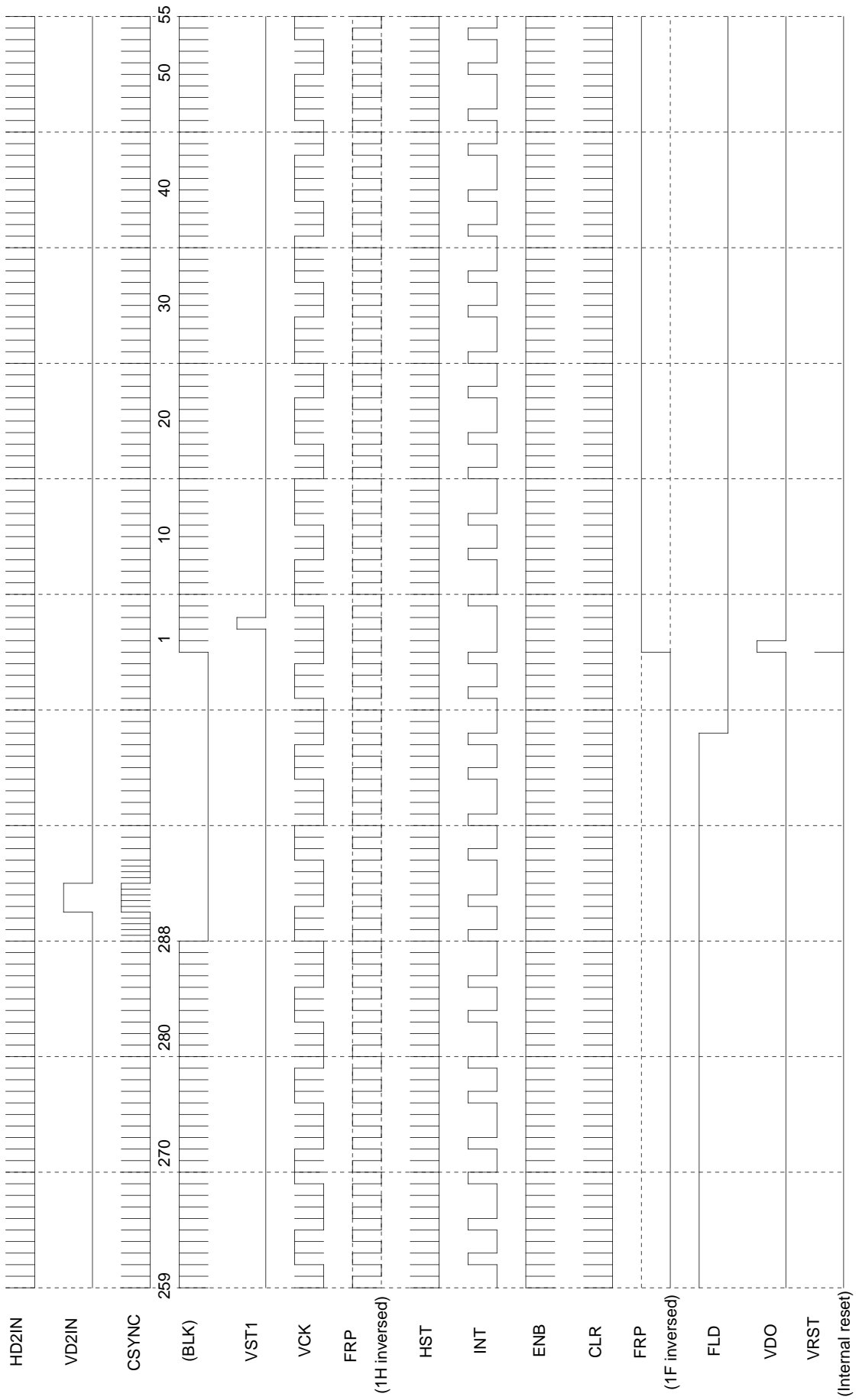

**Vertical Direction Timing Chart (PAL, odd field)**

SLDWN: L (Up scan)

VP: 1110010 LSB

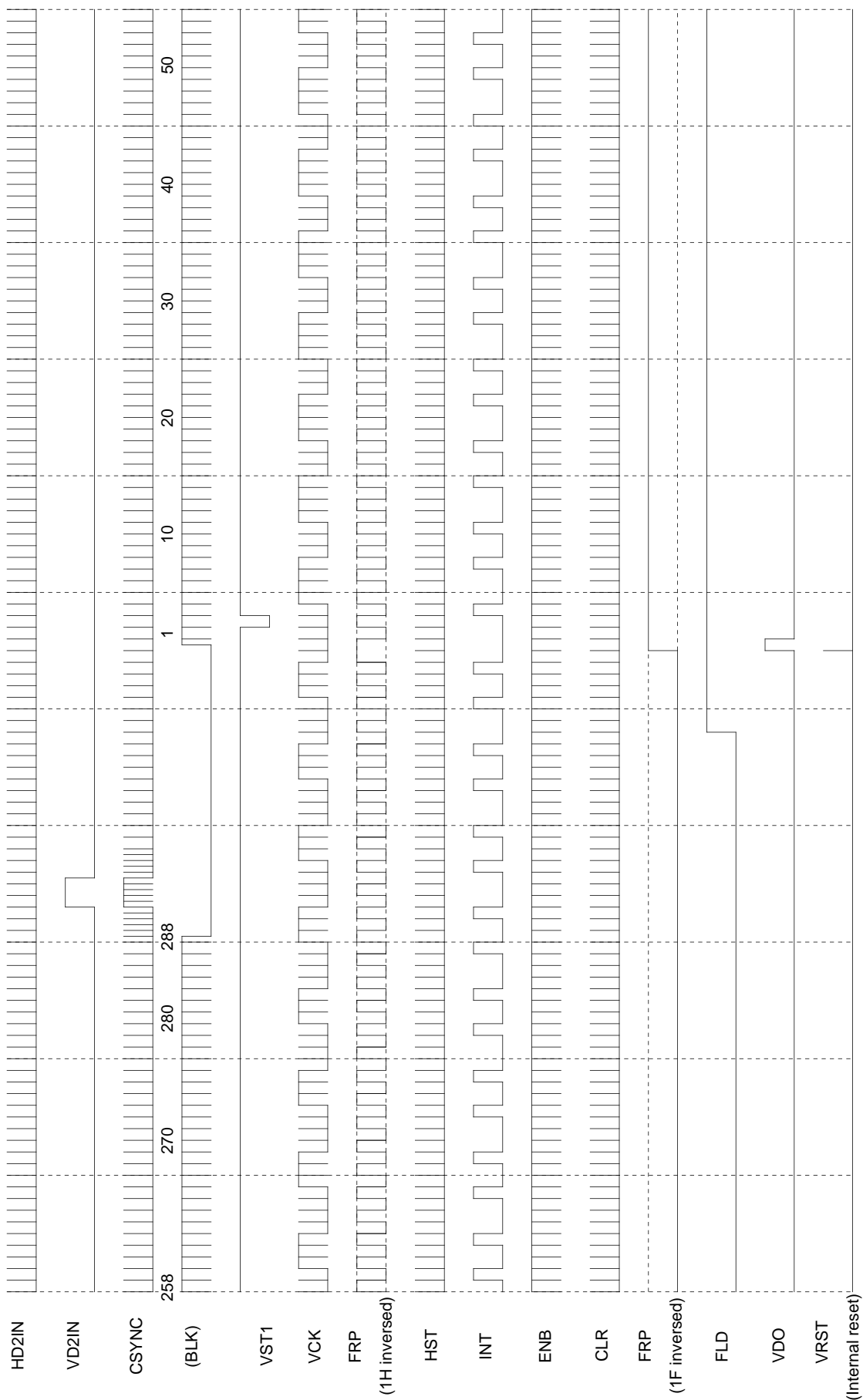

**Vertical Direction Timing Chart (PAL, even field)**

SLDWN: L (Up scan)

VP: 1110010 LSB

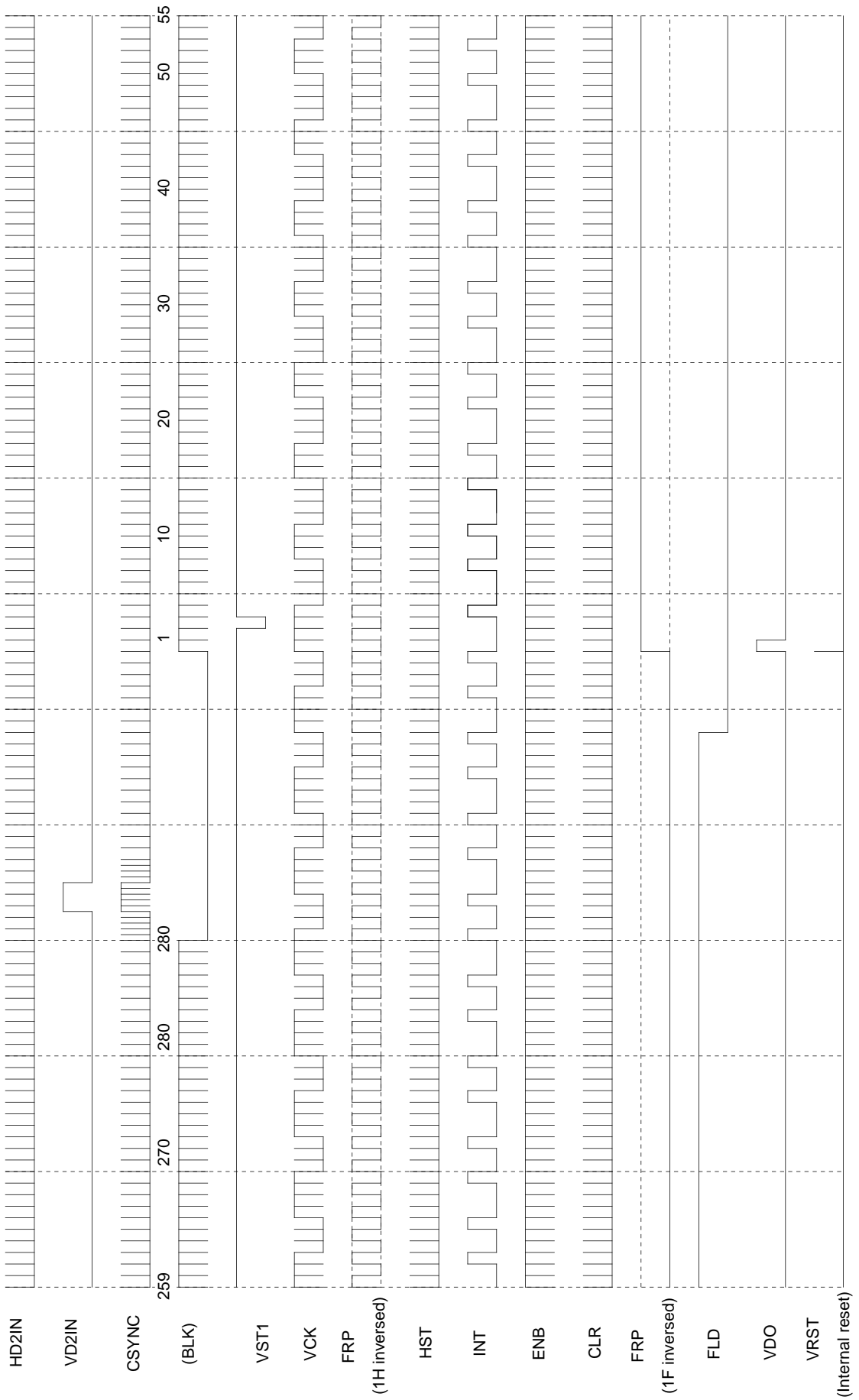

Application Circuit

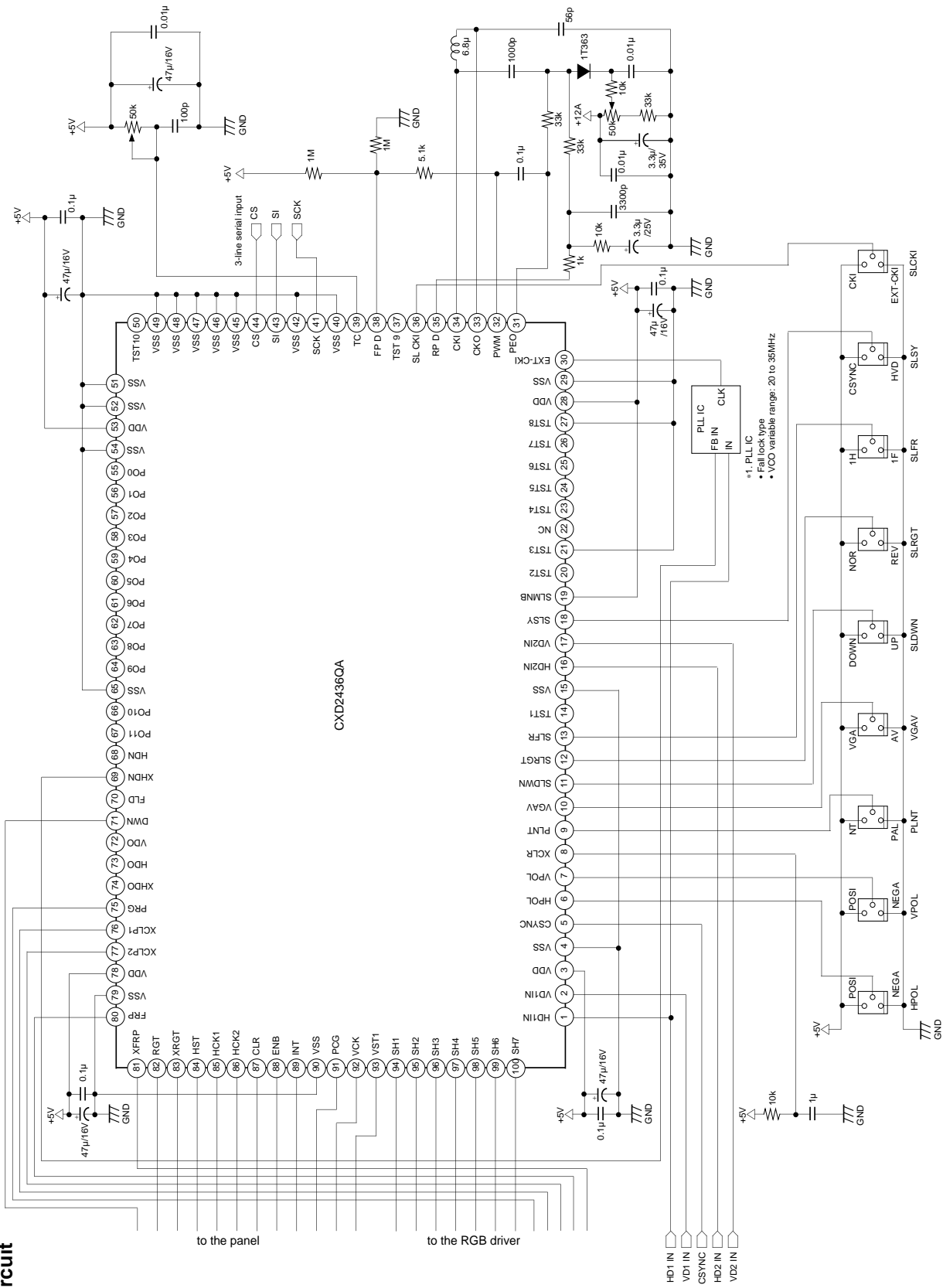

Application circuits shown are typical examples illustrating the operation of the devices. Sony cannot assume responsibility for any problems arising out of the use of these circuits or for any infringement of third party and other right due to same.

Package Outline Unit : mm

100PIN QFP (PLASTIC)

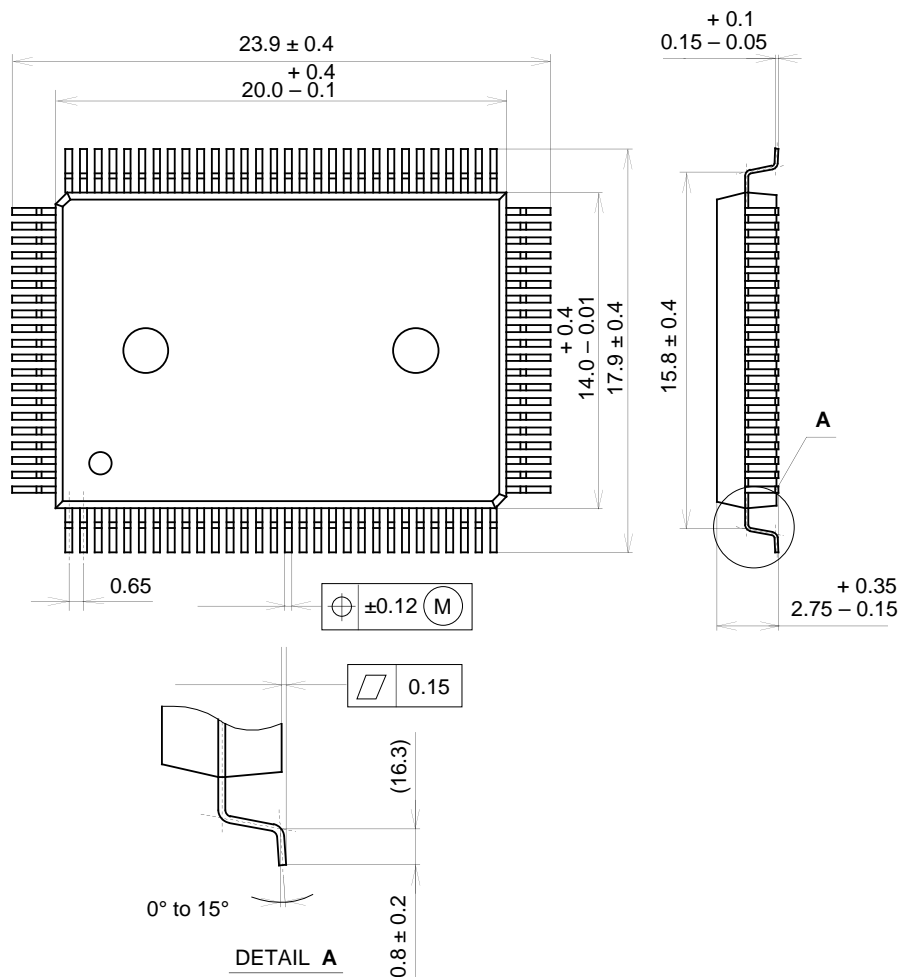

PACKAGE STRUCTURE

SONY CODE	QFP-100P-L01
EIAJ CODE	*QFP100-P-1420-A
JEDEC CODE	_____

PACKAGE MATERIAL	EPOXY RESIN
LEAD TREATMENT	SOLDER PLATING
LEAD MATERIAL	COPPER / 42 ALLOY
PACKAGE WEIGHT	1.4g



LittleDiode supplies new, hard to find or obsolete electronic components and semiconductors all over the world.

With over two million different components listed you are sure to find the part you need.

Feel free to visit us today at our online store:

**[LittleDiode.com](http://LittleDiode.com)**

Looking forward to providing you with the best possible service.