

## Timing Controller for ICX076/077AL

### Description

The CXD2409R is a timing controller for CCD camera systems which use the ICX076/077AL black-and-white CCD image sensors.

### Features

- Supports EIA/CCIR standards
- Electronic iris (electronic shutter) function
- Sync signal generation function
- Backlight compensation function
- AGC flickerless circuit
- Electronic iris power on reset function
- Oscillator frequency: 13.5 MHz

### Absolute Maximum Ratings (Ta = 25°C)

• Supply voltage	V <sub>DD</sub>	V <sub>SS</sub> – 0.5 to +7.0	V
• Input voltage	V <sub>I</sub>	V <sub>SS</sub> – 0.5 to V <sub>DD</sub> + 0.5	V
• Output voltage	V <sub>O</sub>	V <sub>SS</sub> – 0.5 to V <sub>DD</sub> + 0.5	V
• Operating temperature	T <sub>opr</sub>	–20 to +75	°C
• Storage temperature	T <sub>stg</sub>	–55 to +150	°C

### Recommended Operating Conditions

• Supply voltage	V <sub>DD</sub>	5.0 ± 0.25	V
• Operating temperature	T <sub>opr</sub>	–20 to +75	°C

### CCD Image Sensors Used

ICX076/077AL

64 pin LQFP (Plastic)

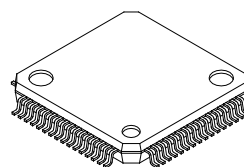

### Applications

- Doorphones
- Small sized surveillance cameras

### Structure

Silicon gate CMOS IC

Sony reserves the right to change products and specifications without prior notice. This information does not convey any license by any implication or otherwise under any patents or other right. Application circuits shown, if any, are typical examples illustrating the operation of the devices. Sony cannot assume responsibility for any problems arising out of the use of these circuits.

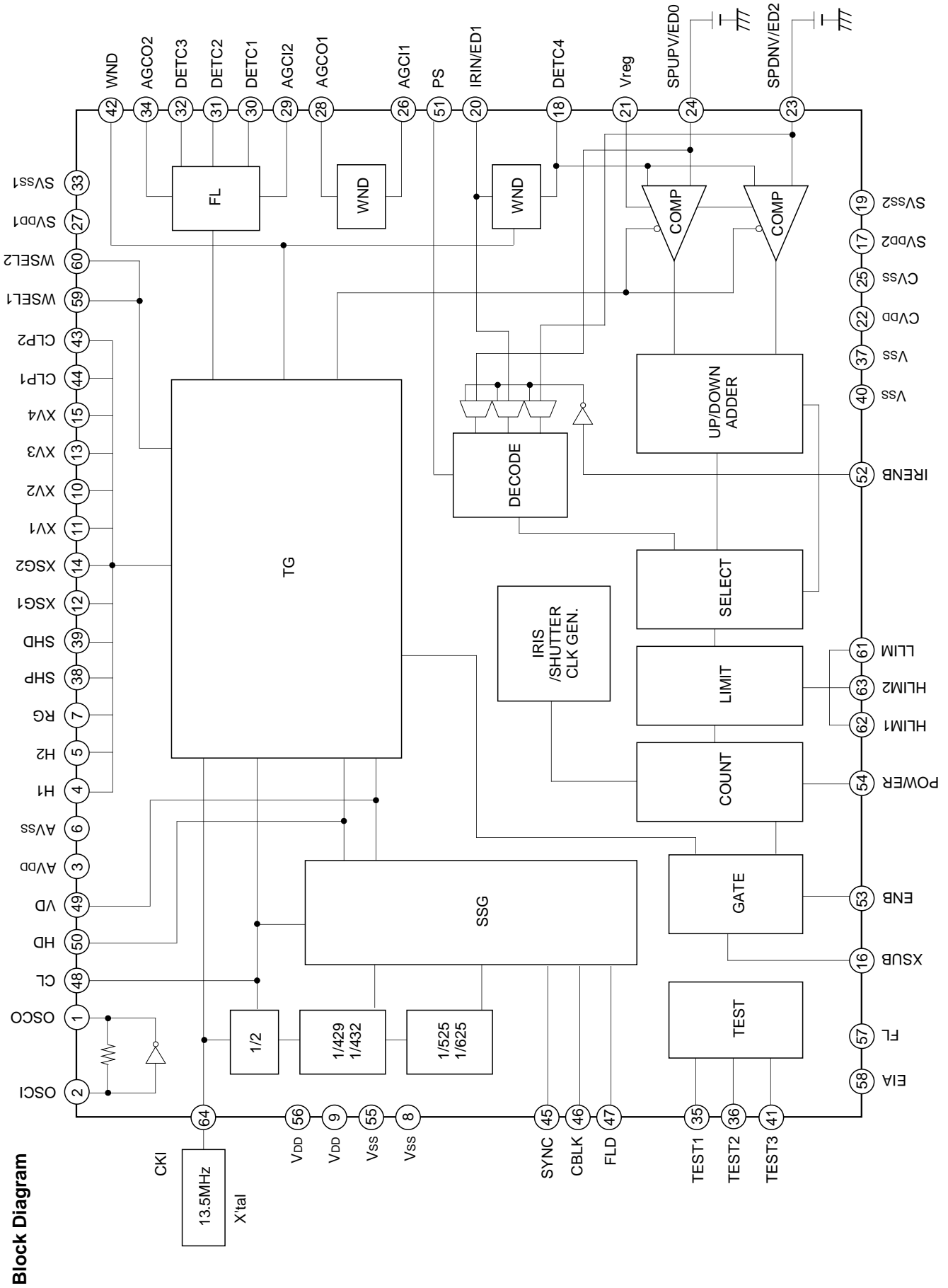

Pin Configuration (Top View)

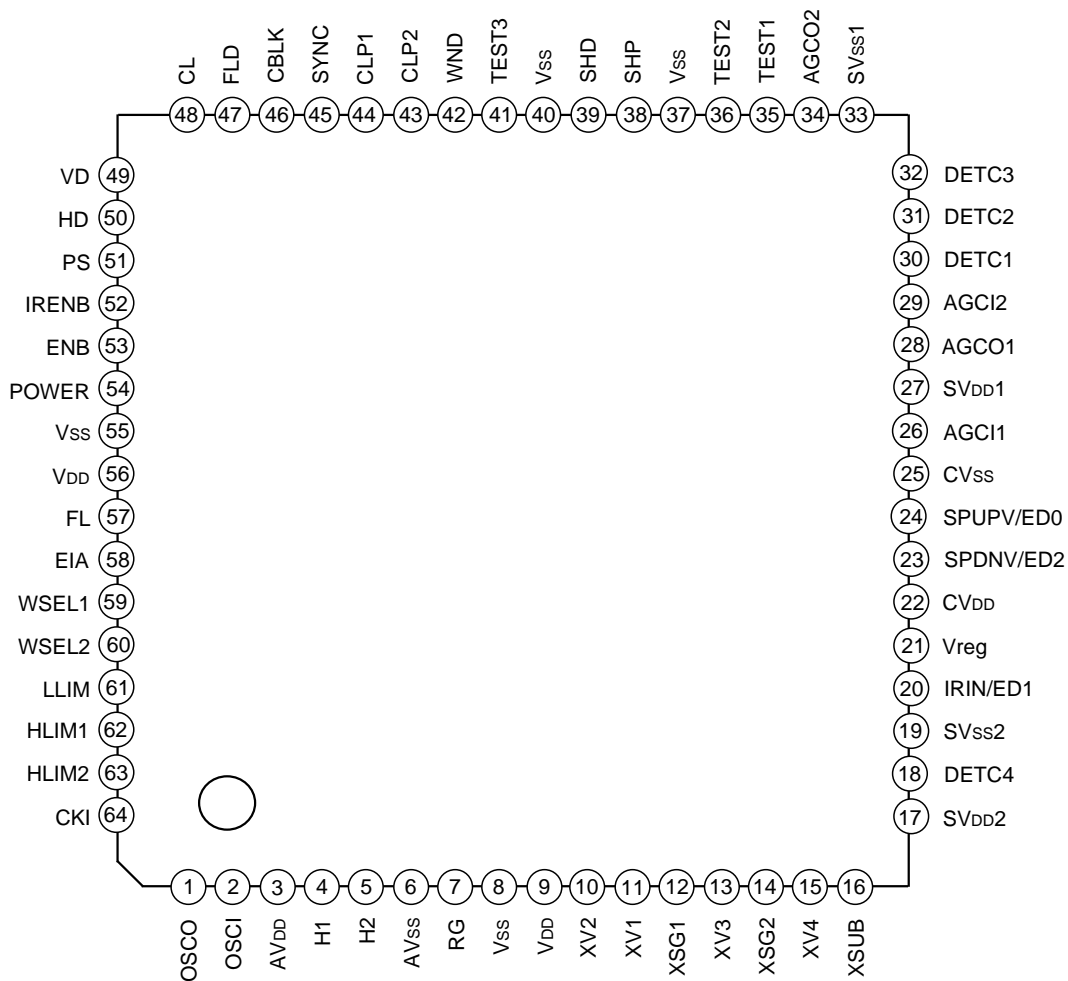

Pin Description

Pin No.	Symbol	I/O	Description
1	OSCO	O	Oscillation inverter output
2	OSCI	I	Oscillation inverter input
3	AVDD	—	Power supply (for H1, H2)
4	H1	O	Clock output for CCD horizontal register drive
5	H2	O	Clock output for CCD horizontal register drive
6	AVss	—	GND (for H1, H2)
7	RG	O	Reset gate pulse output
8	Vss	—	GND
9	VDD	—	Power supply
10	XV2	O	Clock output for CCD vertical register drive
11	XV1	O	Clock output for CCD vertical register drive
12	XSG1	O	CCD sensor charge readout pulse output

Pin No.	Symbol	I/O	Description
13	XV3	O	Clock output for CCD vertical register drive
14	XSG2	O	CCD sensor charge readout pulse output
15	XV4	O	Clock output for CCD vertical register drive
16	XSUB	O	CCD discharge pulse output
17	SV <sub>DD2</sub>	—	Power supply (for the iris window switch)
18	DETC4	O	Capacitor for iris detection
19	SV <sub>SS2</sub>	—	GND (for the iris window switch)
20	IRIN/ED1	I	Iris signal input/shutter speed setting; clock input in serial mode
21	V <sub>reg</sub>	I	Bias current supply for the comparator
22	CV <sub>DD</sub>	—	Power supply (for the comparator)
23	SPDNV/ED2	I	Shutter speed down reference voltage/ shutter speed setting; data input in serial mode
24	SPUPV/ED0	I	Shutter speed up reference voltage/ shutter speed setting; strobe input in serial mode
25	CV <sub>SS</sub>	—	GND (for the comparator)
26	AGCI1	I	AGC detection signal input
27	SV <sub>DD1</sub>	—	Power supply (for the AGC window switch)
28	AGCO1	O	AGC detection signal output
29	AGCI2	I	AGC flickerless circuit input
30	DETC1	O	AGC detection capacitor 1
31	DETC2	O	AGC detection capacitor 2
32	DETC3	O	AGC detection capacitor 3
33	SV <sub>SS1</sub>	—	GND (for the AGC window switch)
34	AGCO2	O	AGC flickerless circuit output
35	TEST1	I	Test input (with the pull-down resistor)
36	TEST2	I	Test input (with the pull-down resistor)
37	V <sub>SS</sub>	—	GND
38	SHP	O	Precharge level sample-and-hold pulse
39	SHD	O	Data sample-and-hold pulse
40	V <sub>SS</sub>	—	GND
41	TEST3	I	Test input (with the pull-down resistor)
42	WND	O	Window pulse output
43	CLP2	O	Pulse output for clamp
44	CLP1	O	Pulse output for clamp
45	SYNC	O	Composite sync output
46	CBLK	O	Composite blanking output
47	FLD	O	Field pulse output

Pin No.	Symbol	I/O	Description
48	CL	O	Master clock output
49	VD	O	Vertical sync signal output
50	HD	O	Horizontal sync signal output
51	PS	I	Electronic shutter speed input switchover Low: serial input; high: parallel input (with the pull-up resistor)
52	IRENB	I	Low: electronic shutter mode; high: electronic iris mode (with the pull-up resistor)
53	ENB	I	Low: XSUB pulse stop; high: XSUB pulse output (with the pull-up resistor)
54	POWER	I	Electronic iris power on reset
55	V <sub>SS</sub>	—	GND
56	V <sub>DD</sub>	—	Power supply
57	FL	I	Low: normal mode; high: AGC flickerless mode (with the pull-down resistor)
58	EIA	I	Low: EIA; high: CCIR (with the pull-down resistor)
59	WSEL1	I	Window pulse output switchover (with the pull-down resistor)
60	WSEL2	I	Window pulse output switchover (with the pull-down resistor)
61	LLIM	I	Electronic iris low speed limiter switchover Low: limiter OFF; high: limiter ON (with the pull-down resistor)
62	HLIM1	I	Electronic iris high speed limiter switchover (with the pull-down resistor)
63	HLIM2	I	Electronic iris high speed limiter switchover (with the pull-down resistor)
64	CKI	I	2 fck clock input

## Electrical Characteristics

## DC Characteristics

(V<sub>DD</sub> = 4.75 to 5.25V, T<sub>opr</sub> = -20 to +75°C)

Item	Symbol	Conditions	Min.	Typ.	Max.	Unit
Supply voltage Pins 3, 9, 17, 22, 27, and 56	V <sub>DD</sub>		4.75	5.0	5.25	V
Input voltage 1 All input pins except Pins 20, 21, 23, 24, 26, and 29	V <sub>IH</sub>		0.7V <sub>DD</sub>			V
	V <sub>IL</sub>				0.3V <sub>DD</sub>	V
Input voltage 2 Pins 20, 21, 23, 24, 26, and 29	V <sub>IN</sub>		1.9		5.0	V
Output voltage 1 Pins 4, 5, and 7	V <sub>OH1</sub>	I <sub>OH</sub> = -7mA	V <sub>DD</sub> - 0.8			V
	V <sub>OL1</sub>	I <sub>OL</sub> = 20mA			0.4	V
Output voltage 2 Pins 38 and 39	V <sub>OH2</sub>	I <sub>OH</sub> = -4mA	V <sub>DD</sub> - 0.8			V
	V <sub>OL2</sub>	I <sub>OL</sub> = 8mA			0.4	V
Output voltage 3 Pins 18, 28, 30, 31, 32, and 34	V <sub>OH3</sub>					V
	V <sub>OL3</sub>					V
Output voltage 4 Pin 48	V <sub>OH4</sub>	I <sub>OH</sub> = -4mA	V <sub>DD</sub> - 0.8			V
	V <sub>OL4</sub>	I <sub>OL</sub> = 8mA			0.4	V
Output voltage 5 Pins 10, 11, 12, 13, 14, 15, 16, 42, 43, 44, 45, 46, 47, 49, and 50	V <sub>OH5</sub>	I <sub>OH</sub> = -2mA	V <sub>DD</sub> - 0.8			V
	V <sub>OL5</sub>	I <sub>OL</sub> = 4mA			0.4	V
Feedback resistance	R <sub>FB</sub>	V <sub>IN</sub> = V <sub>SS</sub> or V <sub>DD</sub>	250k	1M	2.5M	Ω
Pull-up resistance	R <sub>PU</sub>		20k	50k	125k	Ω
Pull-down resistance	R <sub>PD</sub>		20k	50k	125k	Ω
Analog switch ON resistance	R <sub>ON</sub>	V <sub>IN</sub> = 2.5V ± 1V			200	Ω
Current consumption	I <sub>DD</sub>		20k	50k	125k	mA

## Input/Output Capacitance

(V<sub>DD</sub> = V<sub>SS</sub> = 0V, V<sub>I</sub> or V<sub>O</sub> = 0V, f<sub>M</sub> = 1MHz)

Item	Symbol	Min.	Typ.	Max.	Unit
Input pin capacitance	C <sub>IN</sub>			9	pF
Output pin capacitance	C <sub>OUT</sub>			11	pF

## Mode Control

Pin No.	Symbol	I/O	Low	High	Remarks
52	IRENB	I	Electronic shutter	Electronic iris	Valid when ENB is high.
53	ENB	I	XSUB stop	XSUB output	
58	EIA	I	EIA	CCIR	
59	WSEL1	I	Four types of window settings can be selected by combining WSEL1 and WSEL2.		
60	WSEL2	I			
61	LLIM	I	The minimum shutter speed can be selected during electronic iris mode.		Valid when ENB is high and IRENB is high.
62	HLIM1	I	The maximum shutter speed can be selected during electronic iris mode by combining HLIM1 and HLIM2.		Valid when ENB is high and IRENB is high.
63	HLIM2	I			
57	FL	I	AGC flickerless OFF	AGC flickerless ON	Valid when AGC is used.
51	PS	I	Serial input	Parallel input	Valid when ENB is high and IRENB is low.

- The functions of the pins (Pins 20, 23, and 24) listed below change according to the IRENB (Pin 52) mode setting.

(Valid when ENB is high.)

Pin No.	Symbol	I/O	IRENB	
			Low	High
20	IRIN /ED1	I	Electronic shutter speed setting; clock input in serial mode	IRIS signal input
23	SPDNV /ED2	I	Electronic shutter speed setting; data input in serial mode	Comparator reference voltage input (shutter speed down side)
24	SPUPV /ED0	I	Electronic shutter speed setting; strobe input in serial mode	Comparator reference voltage input (shutter speed up side)

## Description of Operation

### Electronic Shutter/Electronic Iris

By setting the ENB pin (Pin 53) high, the XSUB pulse is output for a specific period to activate the electronic shutter and electronic iris.

#### Electronic Shutter

Parallel input (IRENB = low, PS = high)

Mode		EIA	ENB	IRENB	SPUPV	IRIN	SPDNV	Shutter speed
OFF	EIA	L	L	×	×	×	×	1/60 (s)
	CCIR	H	L	×	×	×	×	1/50 (s)
Electronic shutter	EIA	L	H	L	H	H	H	1/100 (s)
		L	H	L	L	H	H	1/250 (s)
		L	H	L	H	L	H	1/500 (s)
		L	H	L	L	L	H	1/1000 (s)
		L	H	L	H	H	L	1/2000 (s)
		L	H	L	L	H	L	1/5000 (s)
		L	H	L	H	L	L	1/10000 (s)
		L	H	L	L	L	L	1/100000 (s)
	CCIR	H	H	L	H	H	H	1/120 (s)
		H	H	L	L	H	H	1/250 (s)
		H	H	L	H	L	H	1/500 (s)
		H	H	L	L	L	H	1/1000 (s)
		H	H	L	H	H	L	1/2000 (s)
		H	H	L	L	H	L	1/5000 (s)
H		H	L	H	L	L	1/10000 (s)	
H		H	L	L	L	L	1/70000 (s)	

Serial input (IRENB = low, PS = low)

By inputting 8-bit data to the ED2 pin (Pin 23), the electronic shutter speed can be controlled.

Serial input data format

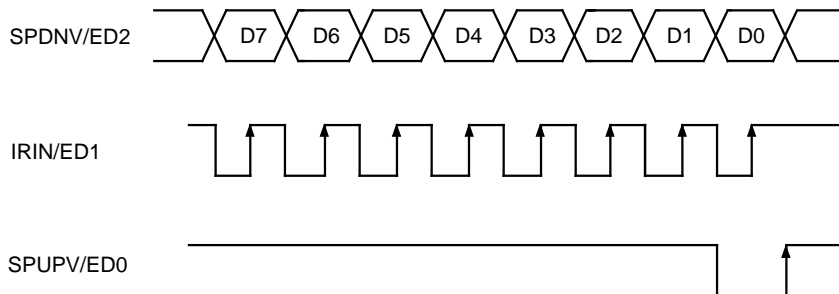

The ED2 (Pin 23) data is latched in the register at the ED1 (Pin 20) rise, and retrieved internally at the ED0 (Pin 24) rise.

Typical shutter speeds

EIA		CCIR	
Shutter speed (s)	DATA (ED0: 8bit)	Shutter speed (s)	DATA (ED0: 8bit)
1/60	11111111 (0 step)	1/50	11111111 (0 step)
1/100	11110110 (9 step)	1/120	11110001 (14 step)
1/250	11100101 (26 step)	1/250	11100011 (28 step)
1/500	11010010 (45 step)	1/500	11010000 (47 step)
1/1000	11000010 (61 step)	1/1000	11000000 (63 step)
1/2000	10111000 (71 step)	1/2000	10110111 (72 step)
1/5000	10101000 (87 step)	1/5000	10100110 (89 step)
1/10000	10011011 (100 step)	1/10000	10011000 (103 step)
1/30000	10000010 (125 step)	1/30000	01111101 (130 step)
1/100000	01101010 (149 step)	1/100000	01100011 (156 step)

AC Characteristics

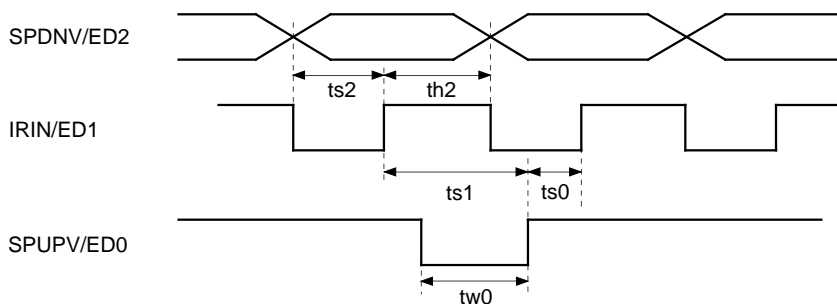

Symbol		Min.	Max.
ts2	SPDNV (ED2) setup time for IRIN (ED1) rise	20ns	—
th2	SPDNV (ED2) hold time for IRIN (ED1) rise	20ns	—
ts1	IRIN (ED1) setup time for SPUPV (ED0) rise	20ns	—
tw0	SPUPV (ED0) pulse width	20ns	50μs
ws0	SPUPV (ED0) setup time for IRIN (ED1) rise	20ns	—

Electronic Iris

(ENB = high, IRENB = high)

Pin No.	Symbol	Function
20	IRIN/ED1	Iris signal input
23	SPDNV/ED2	Comparator reference voltage input for shutter speed down
24	SPUPV/ED0	Comparator reference voltage input for shutter speed up

(a) Electronic iris characteristics

Shutter speed : 1/60 to 1/100000 (s) (EIA)  
 1/50 to 1/70000 (s) (CCIR)

Iris steps : 149 steps (EIA)  
 151 steps (CCIR)

Contraction ratio for one iris step : average 6%

**Note)** When LLIM = low, HLIM1 = low, and HLIM2 = low

(b) LLIM (low speed shutter limiter)

By setting the LLIM pin (Pin 61) high, the minimum shutter speed can be changed.

(ENB = high, IRENB = high)

LLIM	Minimum shutter speed	
	EIA	CCIR
L	1/60	1/50
H	1/100	1/120

(c) HLIM (high speed shutter limiter)

By combining the HLIM1 pin (Pin 62) and the HLIM2 pin (Pin 63), the maximum shutter speed can be changed.

(ENB = high, IRENB = high)

HLIM1	HLIM2	Maximum shutter speed	
		EIA	CCIR
L	L	1/100000 (s)	1/70000 (s)
H	L	1/30000 (s)	1/30000 (s)
H	H	1/10000 (s)	1/10000 (s)
L	H	1/5000 (s)	1/5000 (s)

(d) Power on reset

During electronic iris mode (IRENB = high), the initial settings for the iris are made in the instant the POWER pin (Pin 54) switches from low to high.

The initial setting shutter speed is 1/1000 (s).

By applying the circuit shown below, the shutter speed can be initialized when the power is turned on.

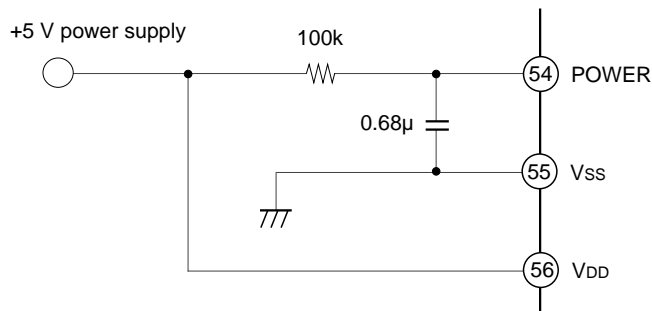

(e) Backlight compensation

By applying the window pulse to the electronic iris detection signal (IRIS) input to IRIN (Pin 20) and the AGC detection signal (DET OUT) input to AGCI1 (Pin 26), backlight compensation can be performed. Compensation is achieved by detecting a limited area with the built-in analog switch for the window and the external sample-and-hold capacitor. In addition, four types of backlight compensation areas can be selected by combining the WSEL1 pin (Pin 59) and WSEL2 pin (Pin 60) as shown in the table below. The basic circuit to perform the window operations is shown in the figure below, and window pulse timing charts are shown on the following pages.

Window types

WSEL1	WSEL2	Minimum shutter speed
L	L	Full measurement*1
H	L	Lower measurement
L	H	Center measurement
H	H	Lower center measurement

\*1 The signal is masked during blanking.

Basic Circuit Configuration

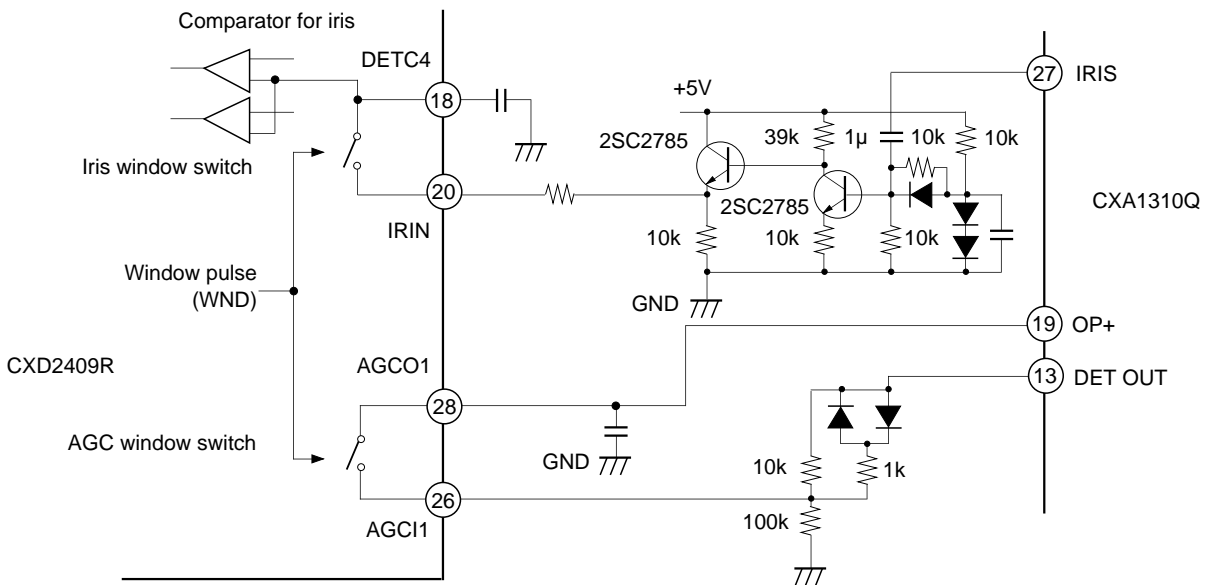

**Window Pulse Response Chart**

**1. Full measurement**

WSEL1 = L / WSEL2 = L

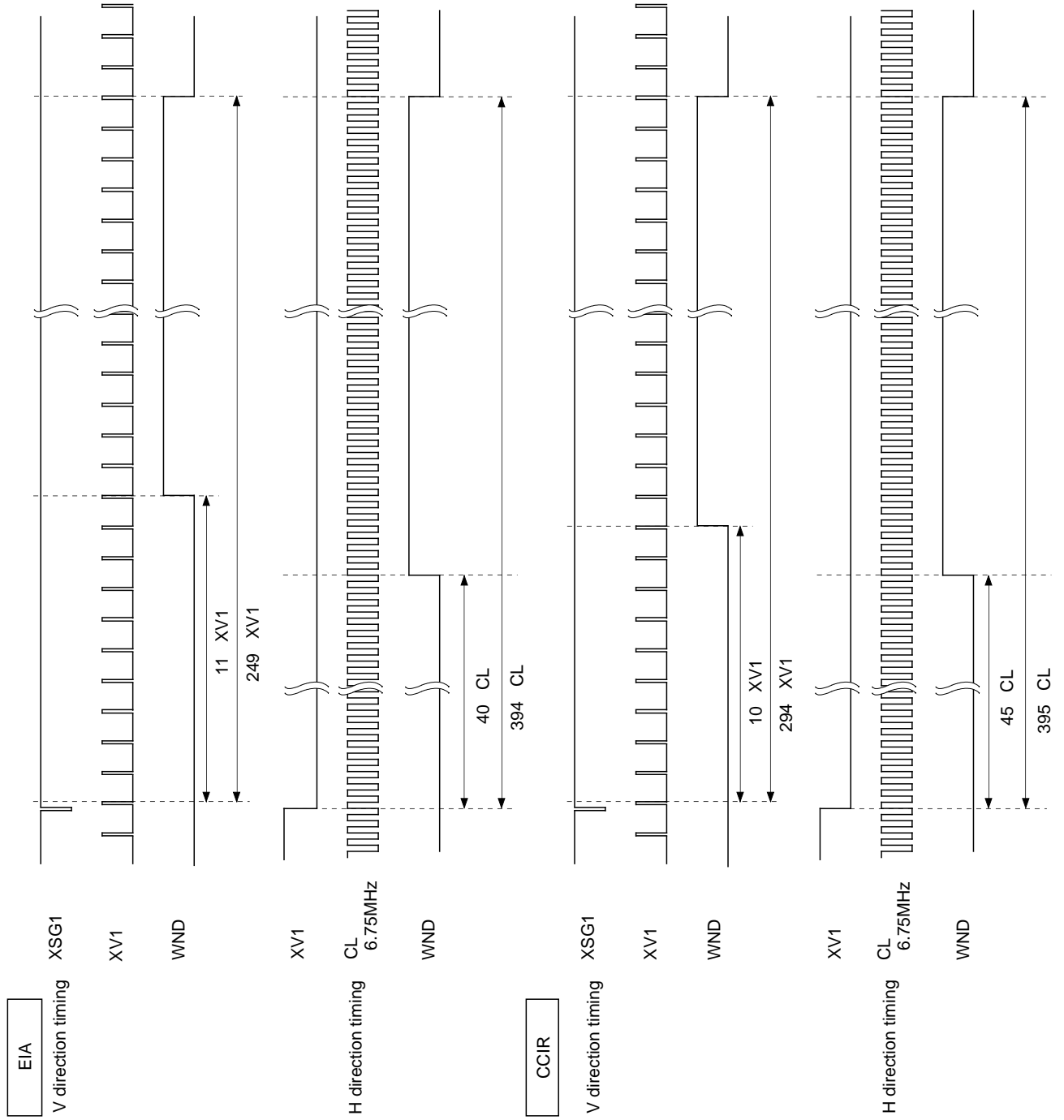
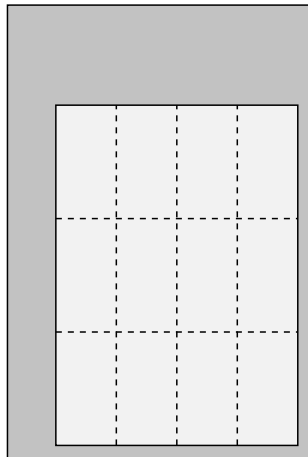

2. Lower measurement

WSEL1 = H / WSEL2 = L

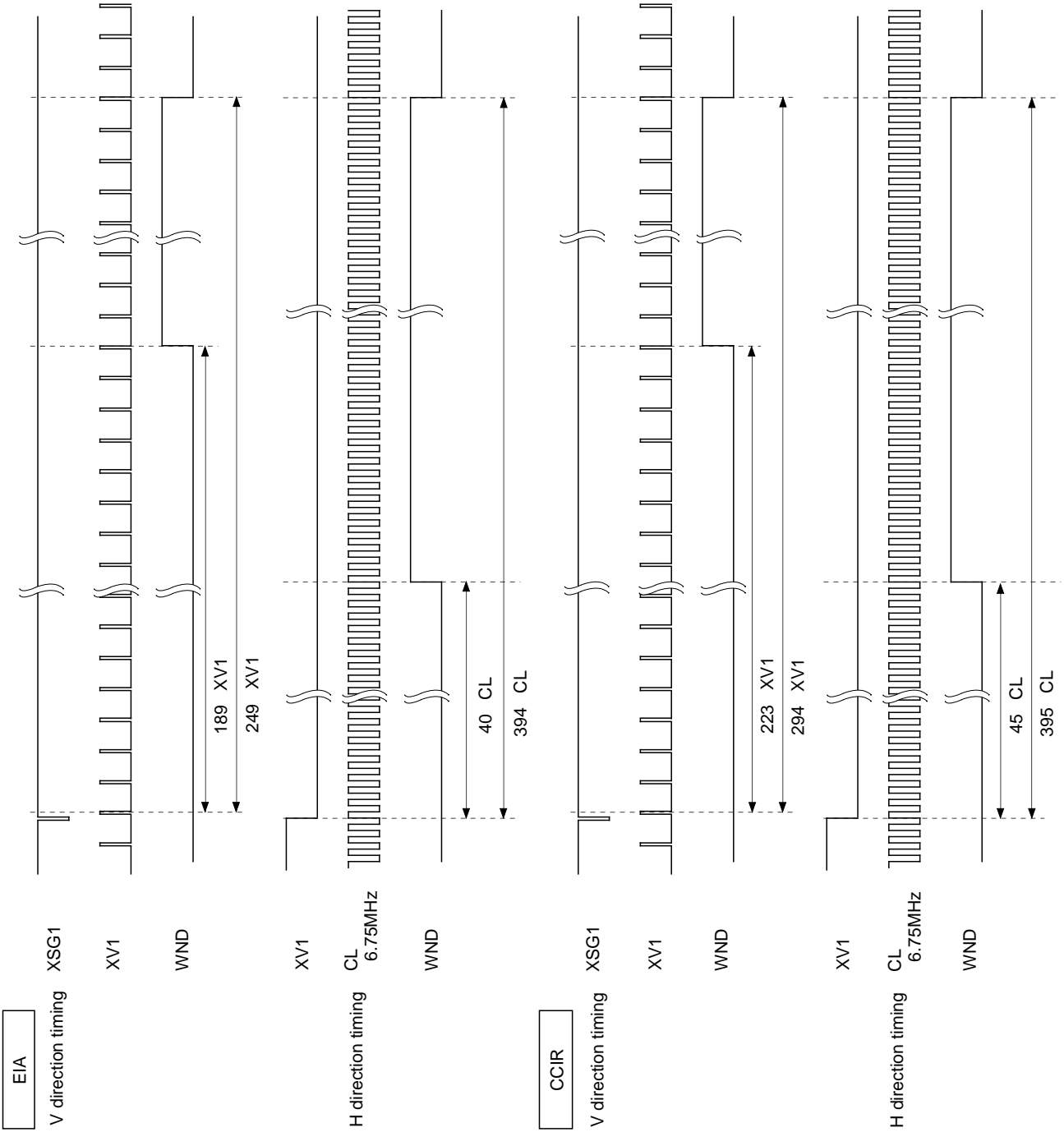
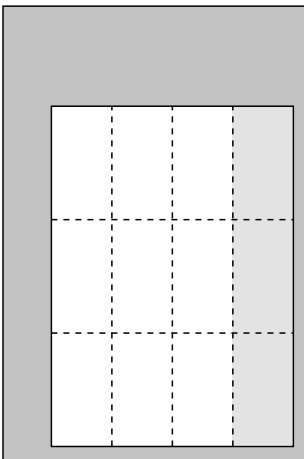

**3. Center measurement**

WSEL1 = L / WSEL2 = H

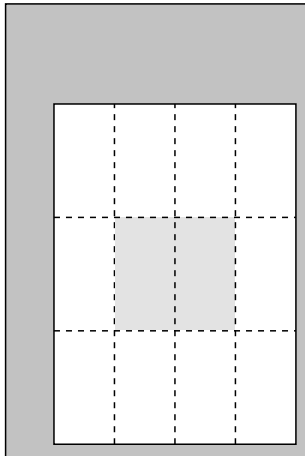

EIA

V direction timing

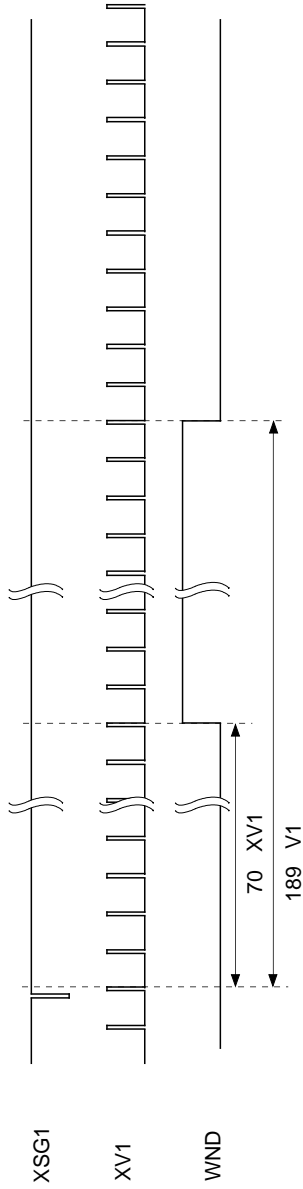

H direction timing

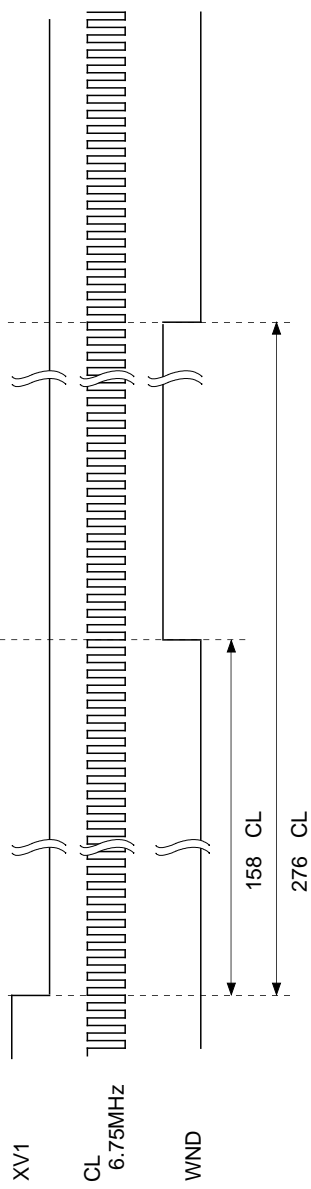

CCIR

V direction timing

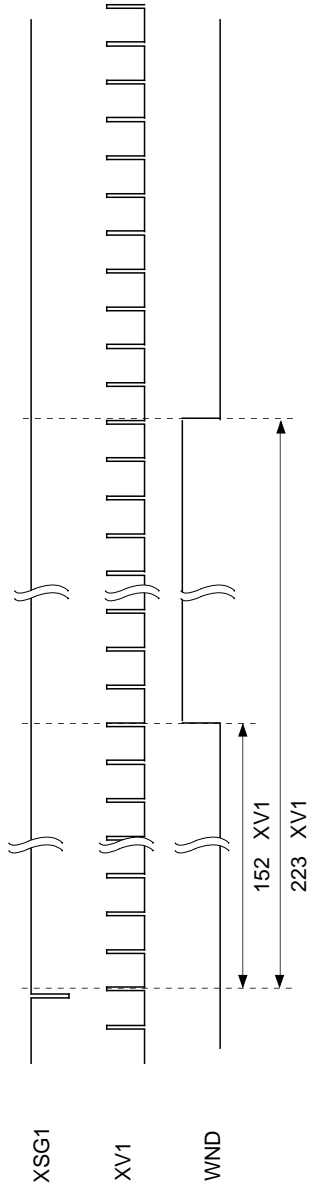

H direction timing

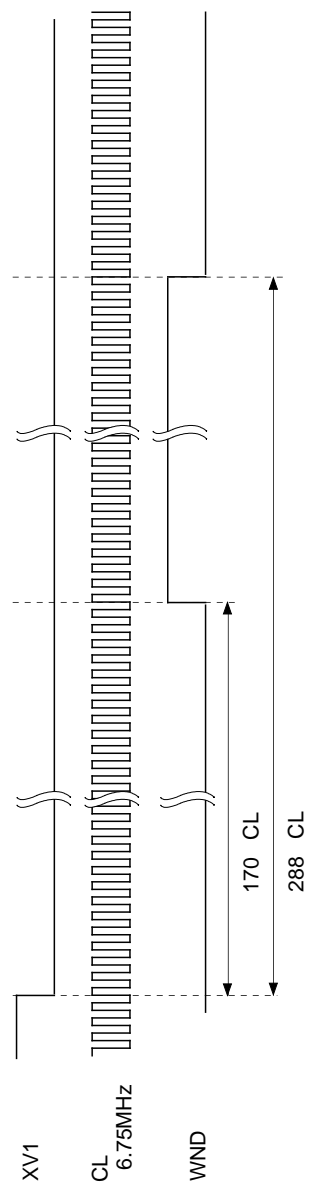

4. Lower center measurement

$WSEL1 = H / WSEL2 = H$

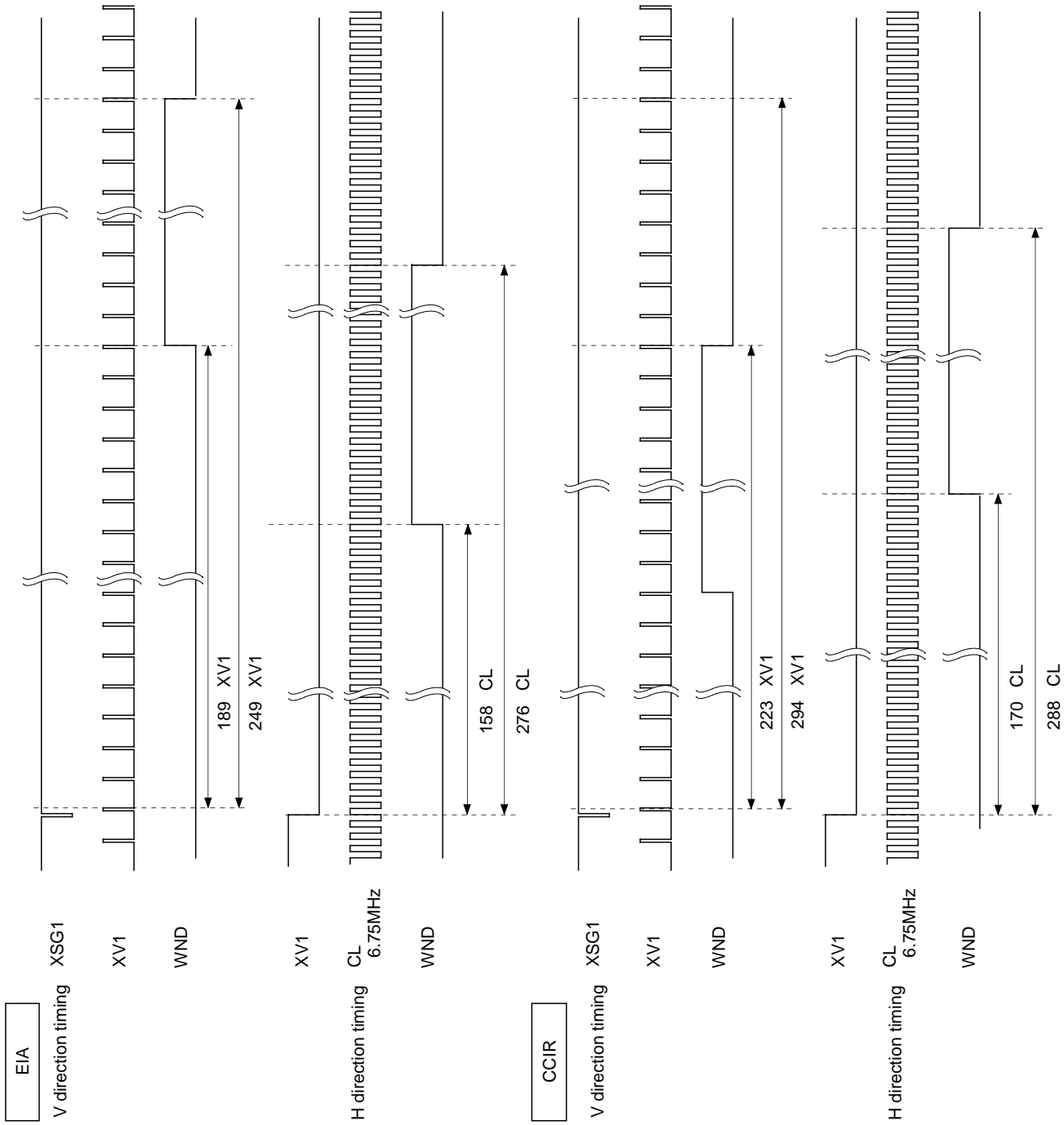
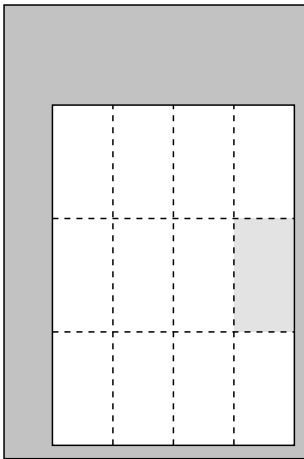

**AGC Flickerless**

By setting the FL pin (Pin 57) of the CXD2409R high when using the CXA1310Q AGC, the fluorescent light flicker component generated by differences between the fluorescent light emission cycle and the EIA field cycle can be controlled.

**Basic Circuit Configuration**

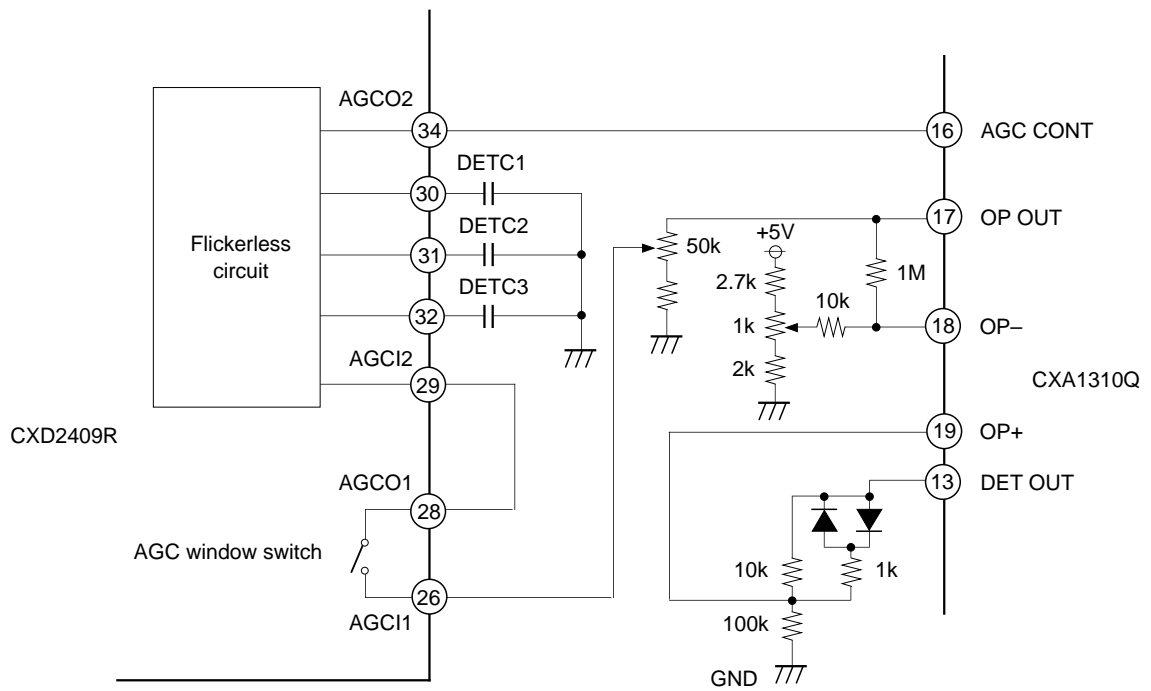



Timing Chart (2) CCIR Vertical Direction

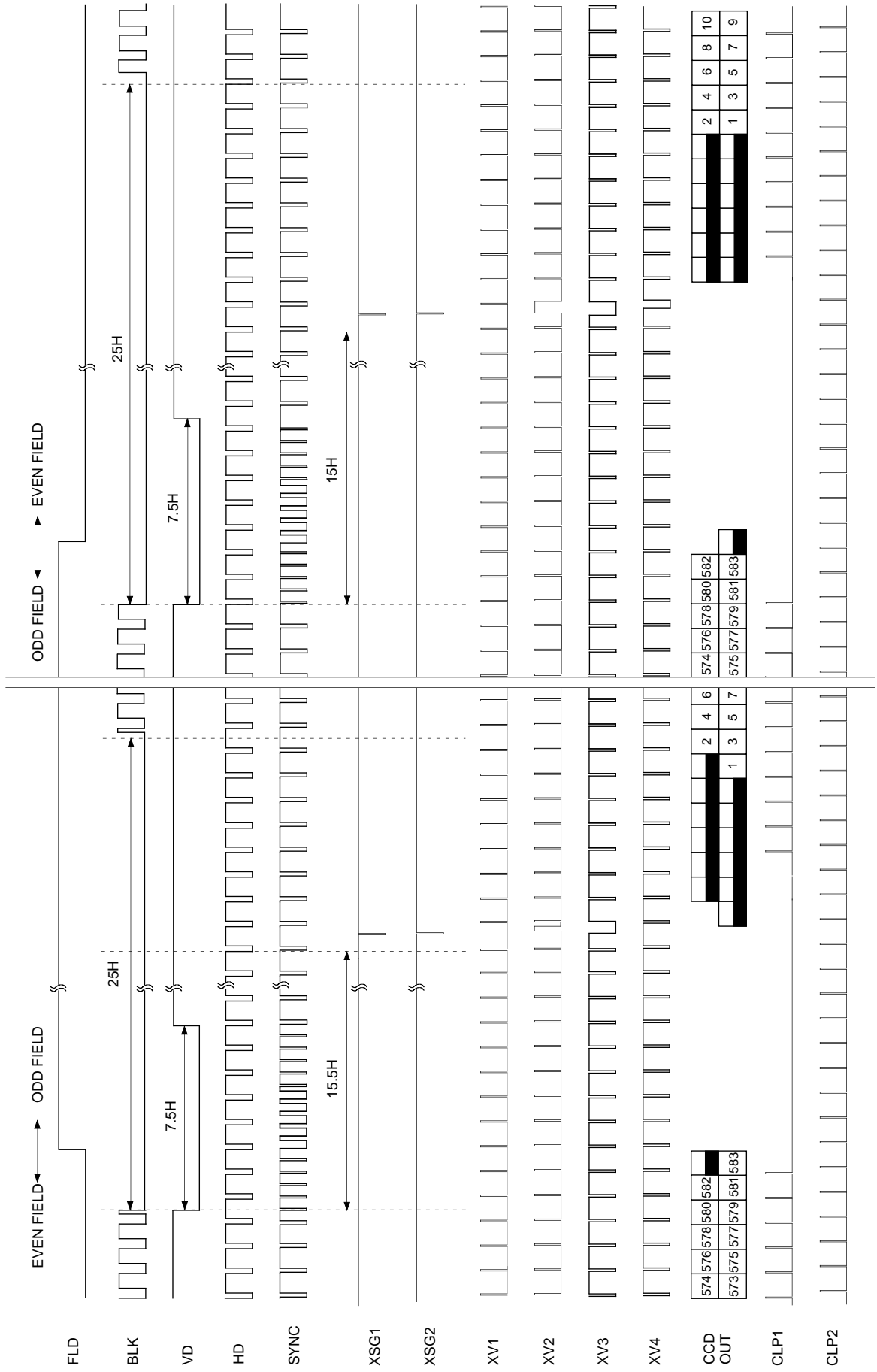

Timing Chart (3) EIA Horizontal Direction

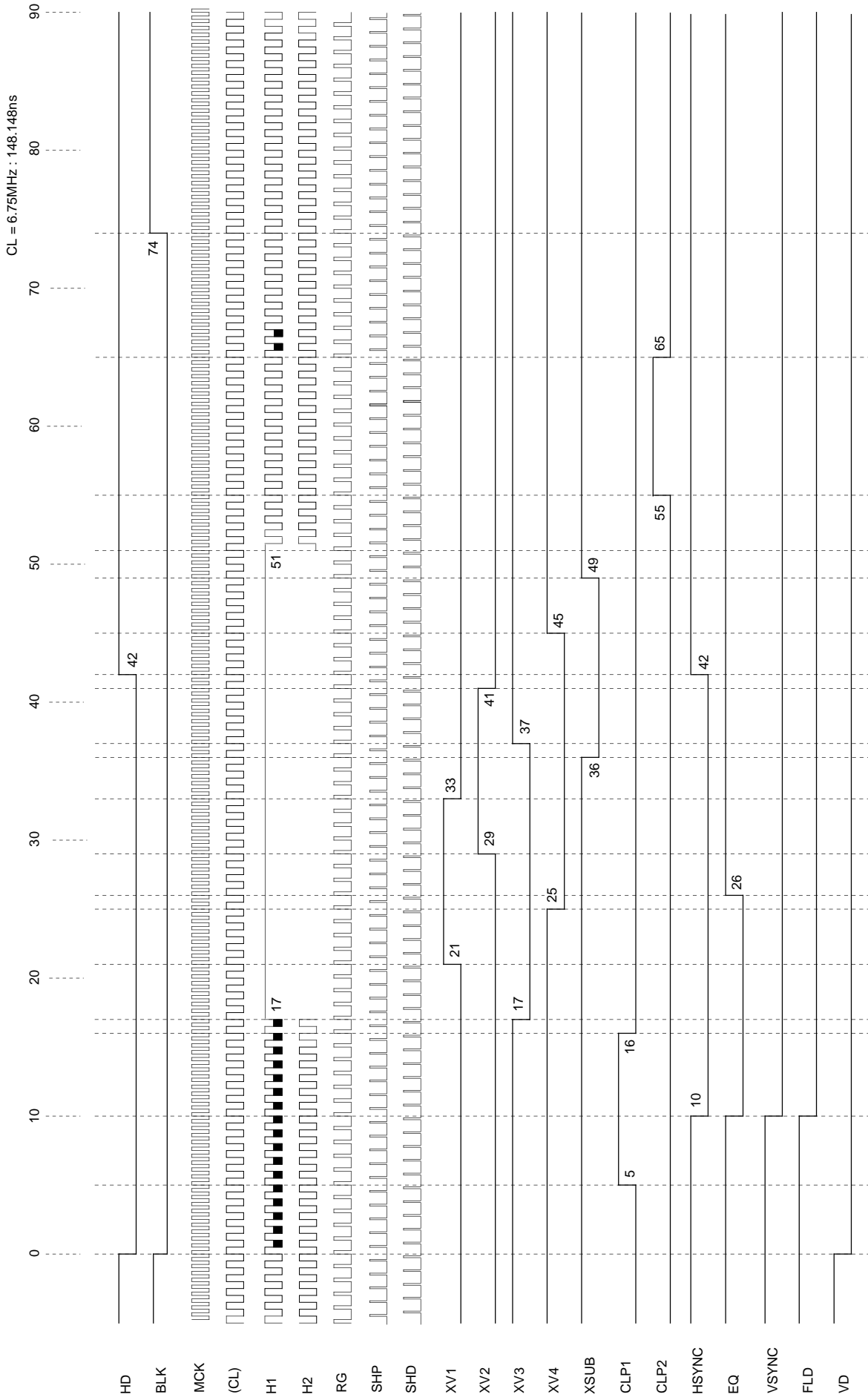

Timing Chart (4) CCIR Horizontal Direction

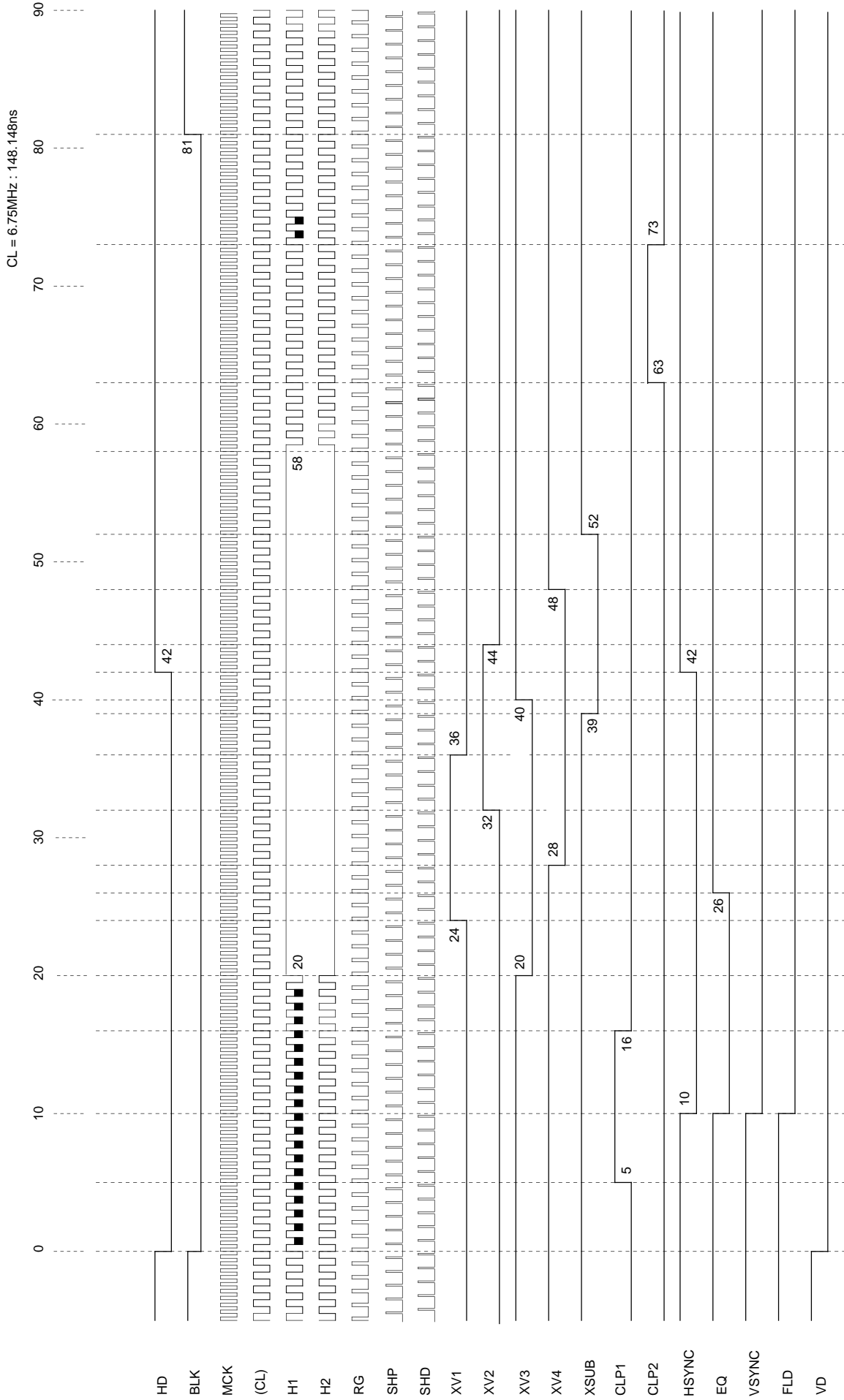



Timing Chart (6) CCIR Charge Readout Timing

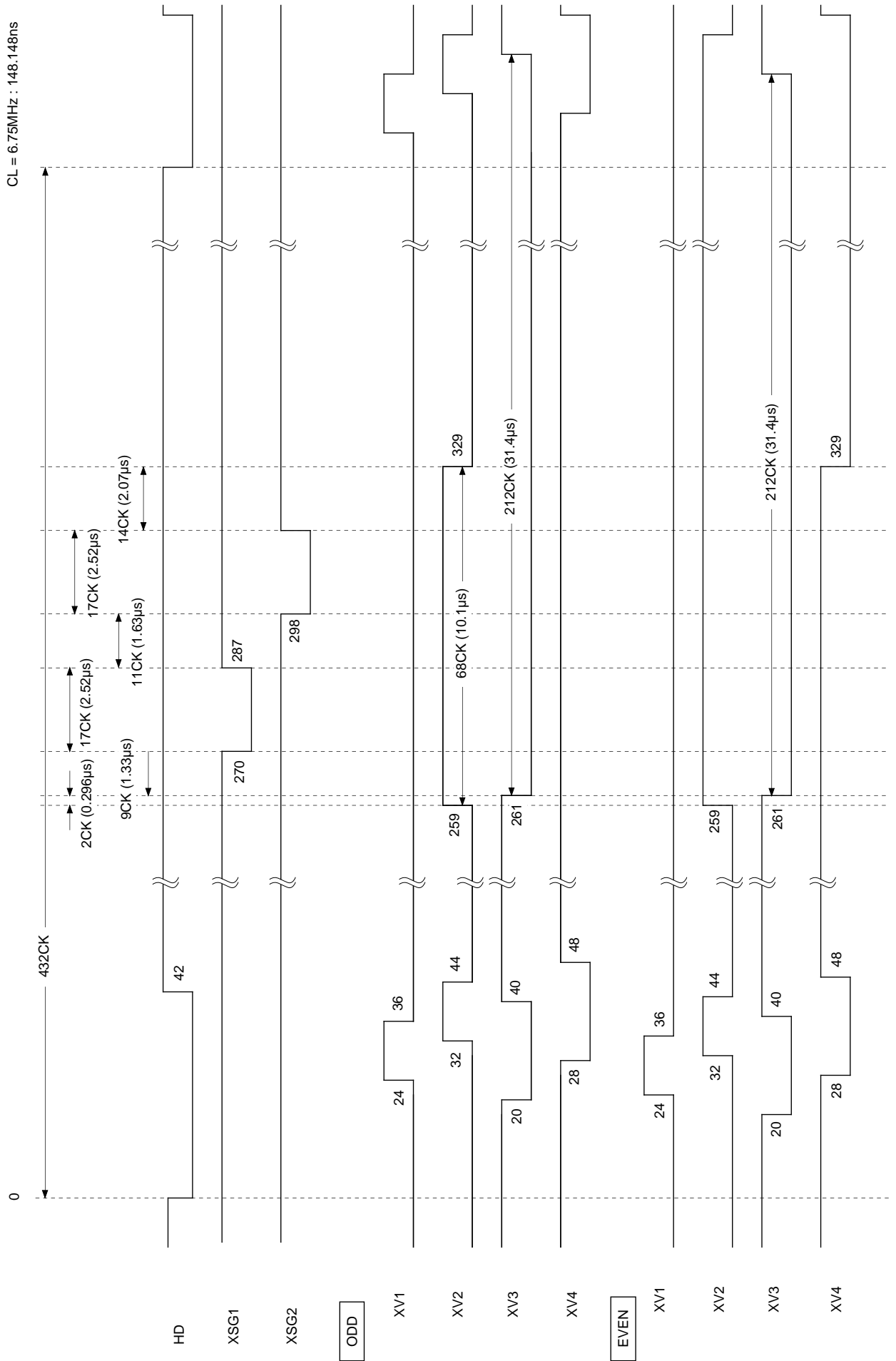

Timing Chart (7) H Effective Period

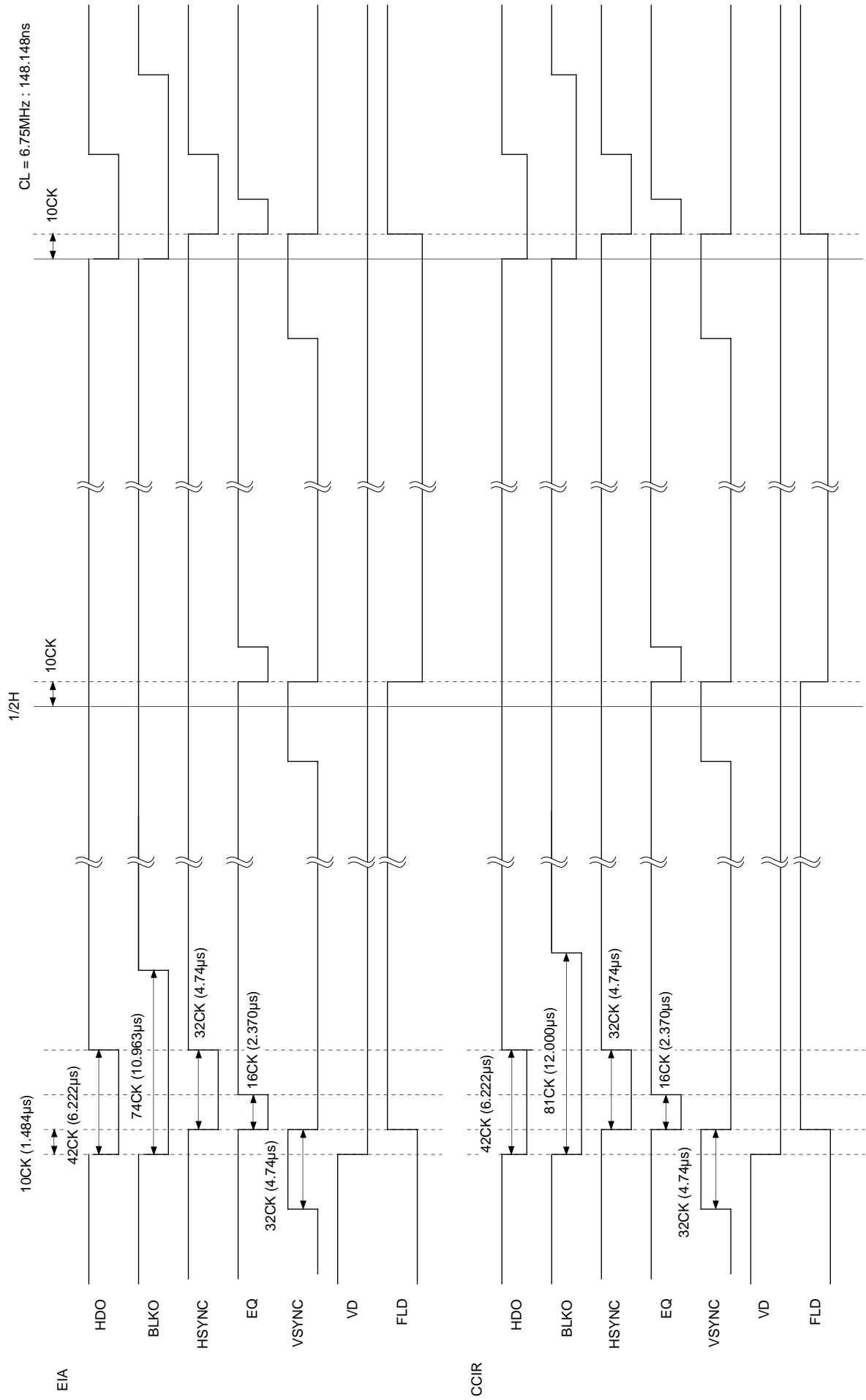

Timing Chart (8) TS + SG High Speed Phase Timing Chart

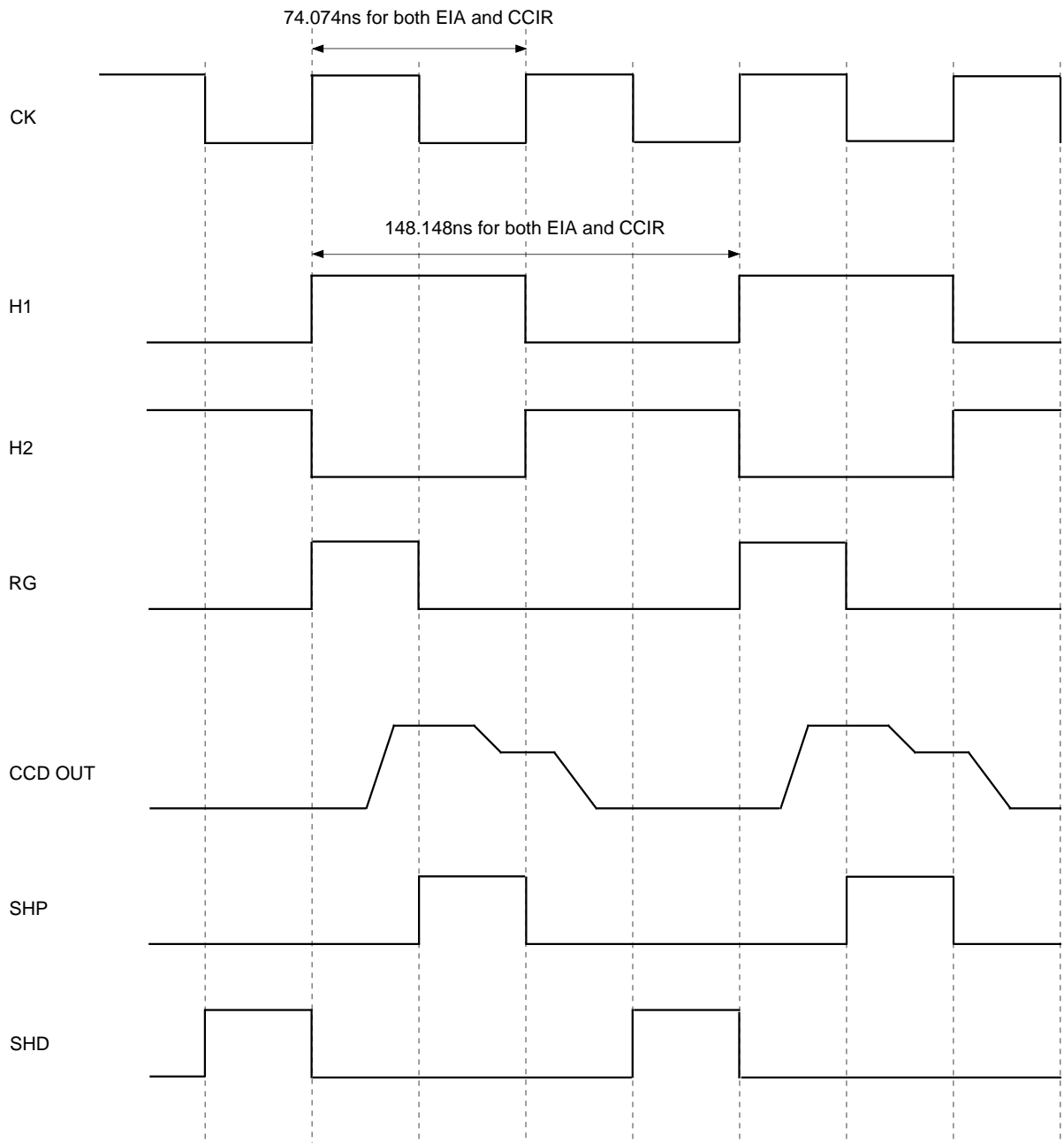

**Application Circuit -EIA-**

- Electronic iris mode
- High speed shutter limit: 1/30000s
- Full measurement
- AGC flickerless mode

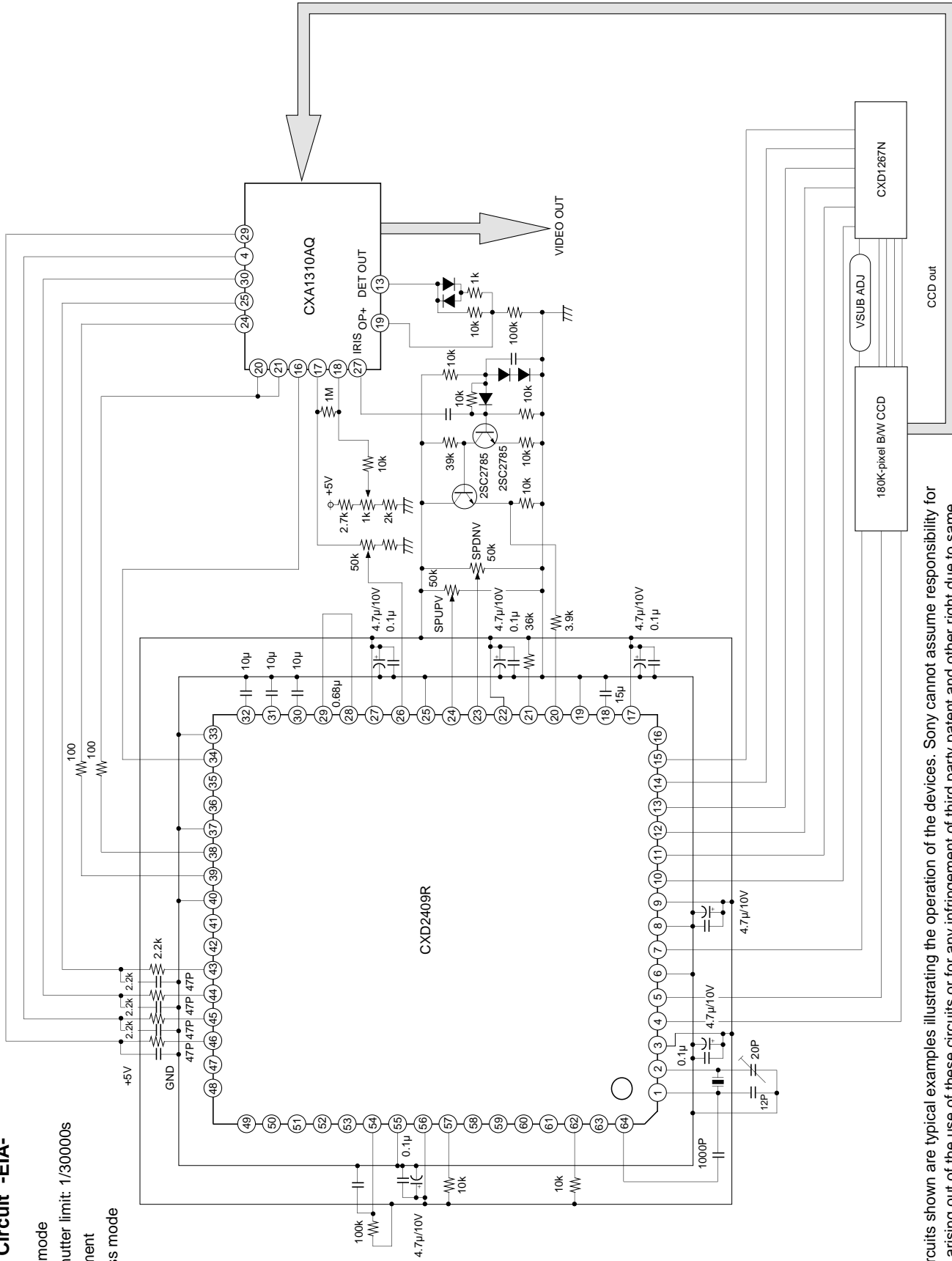

Application circuits shown are typical examples illustrating the operation of the devices. Sony cannot assume responsibility for any problems arising out of the use of these circuits or for any infringement of third party patent and other right due to same.

Package Outline Unit: mm

64PIN LQFP (PLASTIC)

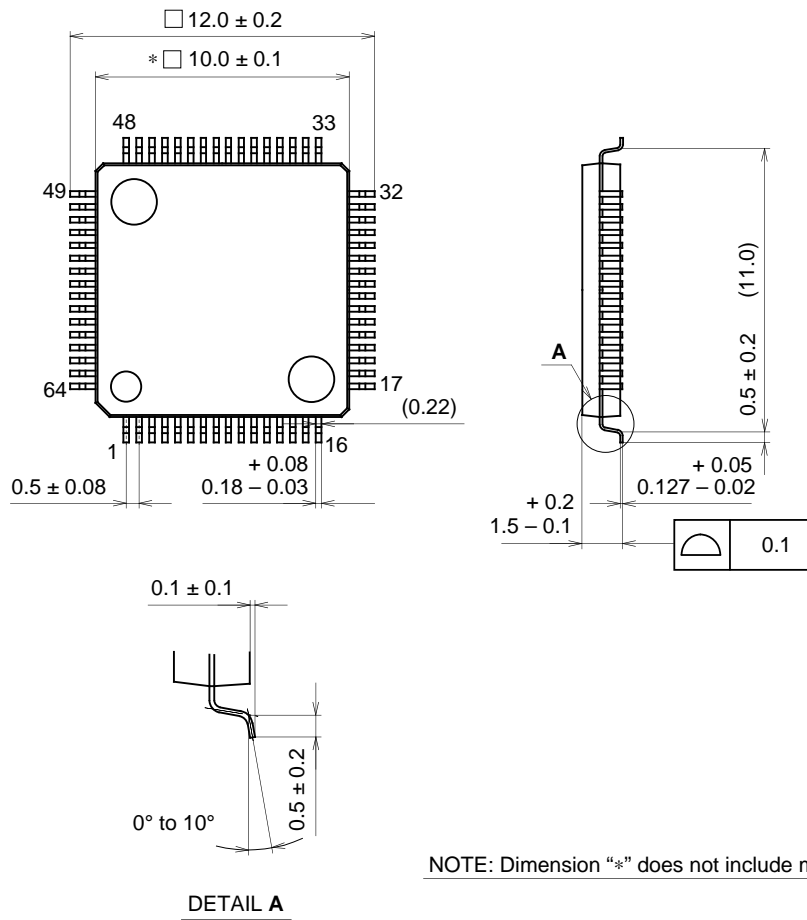

NOTE: Dimension "\*" does not include mold protrusion.

PACKAGE STRUCTURE

SONY CODE	LQFP-64P-L01
EIAJ CODE	LQFP064-P-1010
JEDEC CODE	_____

PACKAGE MATERIAL	EPOXY RESIN
LEAD TREATMENT	SOLDER/PALLADIUM PLATING
LEAD MATERIAL	42/COPPER ALLOY
PACKAGE MASS	0.3g



LittleDiode supplies new, hard to find or obsolete electronic components and semiconductors all over the world.

With over two million different components listed you are sure to find the part you need.

Feel free to visit us today at our online store:

[LittleDiode.com](http://LittleDiode.com)

Looking forward to providing you with the best possible service.