

## 10-bit 85MSPS 3-Channel D/A Converter

### Description

The CXD2309Q is a 10-bit high-speed D/A converter for video band, featuring RGB 3-channel input/output. This is ideal for use in high-definition TVs and high-resolution displays.

### Features

- Resolution 10-bit
- Maximum conversion speed 85MSPS
- RGB 3-channel input/output
- Differential linearity error  $\pm 0.5$  LSB
- Low power consumption 275 mW (200  $\Omega$  load for 2 V<sub>p-p</sub> output)
- Single +5 V power supply
- Low glitch
- 48-pin QFP package

### Structure

Silicon gate CMOS IC

48 pin QFP (Plastic)

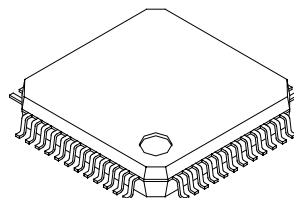

### Absolute Maximum Ratings (T<sub>a</sub>=25 °C)

• Supply voltage	AV <sub>DD</sub> , DV <sub>DD</sub>	7	V
• Input voltage (All pins)	V <sub>IN</sub>	V <sub>DD</sub> +0.5 to V <sub>SS</sub> -0.5	V
• Output current	I <sub>OUT</sub>	0 to 15	mA
• Storage temperature	T <sub>stg</sub>	-55 to +150	°C

### Recommended Operating Conditions

• Supply voltage	AV <sub>DD</sub> , AV <sub>SS</sub>	4.75 to 5.25	V
	DV <sub>DD</sub> , DV <sub>SS</sub>	4.75 to 5.25	V
• Reference input voltage	V <sub>REF</sub>	0.5 to 2.0	V
• Clock pulse width	T <sub>PW1</sub> , T <sub>PW0</sub>	9 (min.)	ns
• Operating temperature	T <sub>opr</sub>	-20 to +85	°C

Sony reserves the right to change products and specifications without prior notice. This information does not convey any license by any implication or otherwise under any patents or other right. Application circuits shown, if any, are typical examples illustrating the operation of the devices. Sony cannot assume responsibility for any problems arising out of the use of these circuits.

Block Diagram

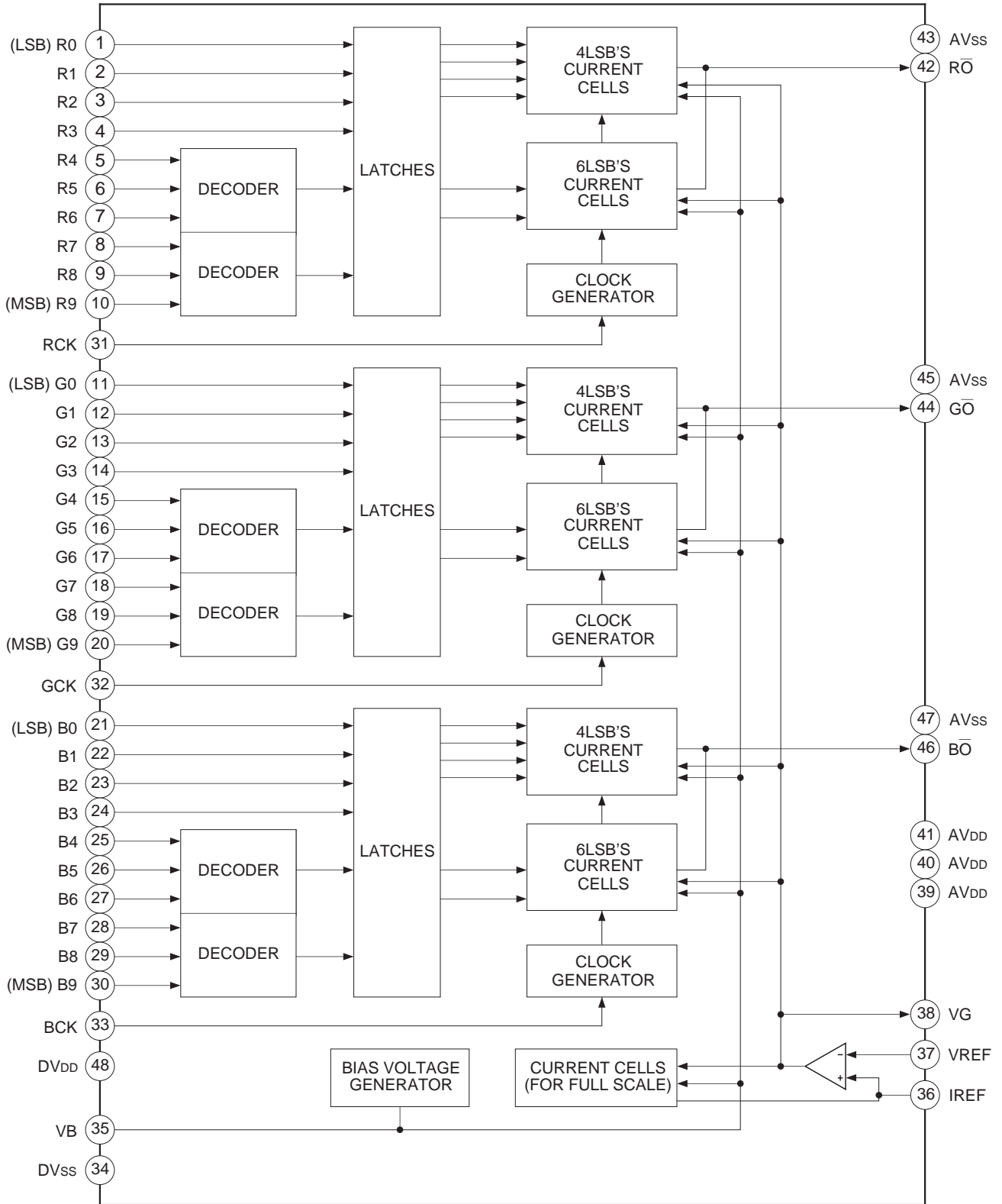

Pin Configuration

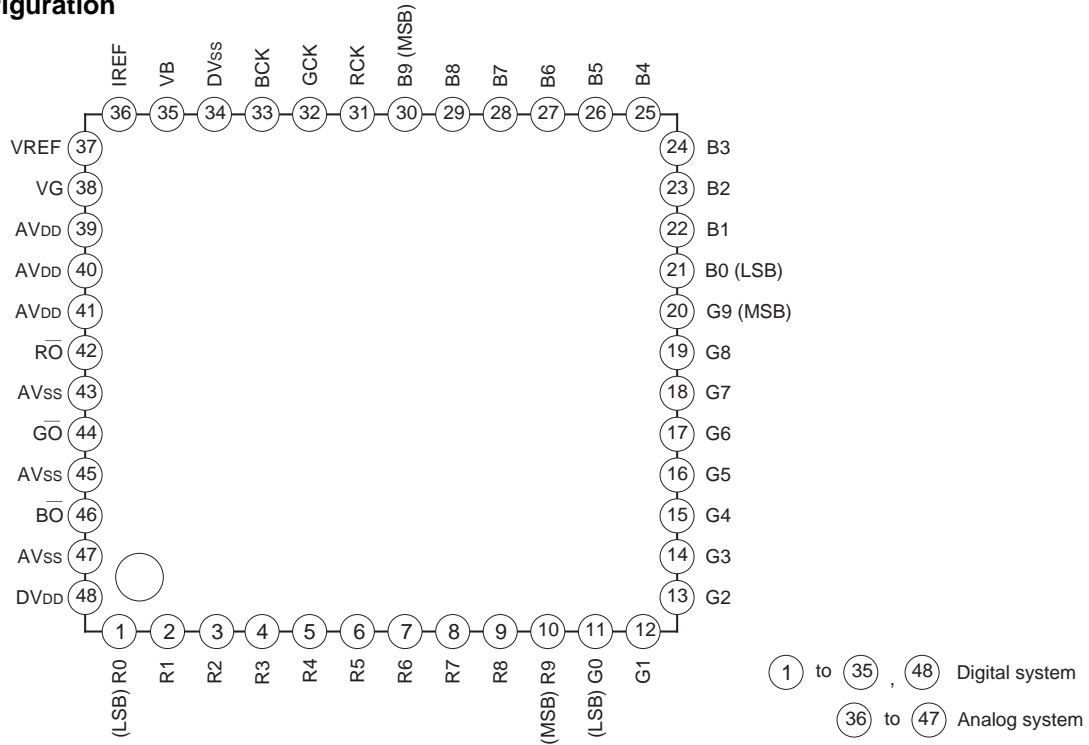

Pin Description and Equivalent Circuit

Pin No.	Symbol	I/ $\bar{O}$	Equivalent circuit	Description
1 to 10	R0 to R9	I		Digital input. 1 pin R0 (LSB) to 10 pin R9 (MSB) 11 pin G0 (LSB) to 20 pin G9 (MSB) 21 pin B0 (LSB) to 30 pin B9 (MSB)
11 to 20	G0 to G9			
21 to 30	B0 to B9			
31	RCLK	I		Clock input.
32	GCLK			
33	BCLK			
34	DVSS	—		Digital ground.
35	VB	$\bar{O}$		Connect an approximately 0.1 $\mu$ F capacitor.

Pin No.	Symbol	I/O	Equivalent circuit	Description
36	IREF	$\bar{O}$		Reference current output. Connect an "R <sub>IR</sub> " resistor which are 16 times the output resistance "R <sub>OUT</sub> ".
37	VREF	I		Reference voltage input. Sets an output full-scale value.
38	VG	$\bar{O}$		Connect an approximately 0.1 μF capacitor.
39 to 41	AVDD	—		Analog power supply.
42	R $\bar{O}$	$\bar{O}$		Current output. Output can be obtained by connecting a resistor (200 Ω typ.).
44	G $\bar{O}$			
46	B $\bar{O}$			
43, 45, 47	AVSS	—		Analog ground.
48	DVDD	—		Digital power supply.

**Electrical Characteristics** (f<sub>CLK</sub>=85 MHz, AV<sub>DD</sub>=DV<sub>DD</sub>=5 V, R<sub>OUT</sub>=200 Ω, V<sub>REF</sub>=2.0 V, R<sub>IR</sub>=3.3 kΩ, Ta=25°C)

Item	Symbol	Measurement conditions	Min.	Typ.	Max.	Unit
Resolution	n			10		bit
Conversion speed	f <sub>CLK</sub>	AV <sub>DD</sub> =DV <sub>DD</sub> =4.75 to 5.25 V Ta=-20 to +85 °C	0		85	MSPS
Integral non-linearity error	EL	Endpoint	-2.0		2.0	LSB
Differential non-linearity error	Ed		-0.5		0.5	LSB
Precision guaranteed output voltage range	V <sub>OC</sub>		1.8	1.92	2.0	V
Output full-scale voltage	V <sub>FS</sub>		1.8	1.92	2.0	V
Output full-scale ratio *1	F <sub>SR</sub>		0		3	%
Output full-scale current	I <sub>FS</sub>		9.0	9.6	10	mA
Output offset voltage	V <sub>OS</sub>	When "0000000000" data input			1	mV
Glitch energy	GE	R <sub>OUT</sub> =100 Ω, 1 V <sub>p-p</sub> output		50		pV•s
Crosstalk	CT	When 10 MHz sin wave input	F <sub>CLK</sub> =50 MHz	40	42	dB
			F <sub>CLK</sub> =85 MHz		40	
SN ratio	SNR	When 1 MHz sin wave input	F <sub>CLK</sub> =50 MHz	50	55	dB
			F <sub>CLK</sub> =85 MHz		50	
Supply current	I <sub>DD</sub>	When 10 MHz sin wave output	F <sub>CLK</sub> =50 MHz		48	mA
			F <sub>CLK</sub> =85 MHz		55	
Analog input resistance	R <sub>IN</sub>	V <sub>REF</sub>	1			MΩ
Input capacitance	C <sub>I</sub>				9	pF
Output capacitance	C <sub>O</sub>			125		pF
Digital input voltage	V <sub>IH</sub>	AV <sub>DD</sub> =DV <sub>DD</sub> =4.75 to 5.25 V Ta=-20 to +75 °C	2.15			V
	V <sub>IL</sub>					
Digital input current	I <sub>IH</sub>	AV <sub>DD</sub> =DV <sub>DD</sub> =4.75 to 5.25 V Ta=-20 to +75 °C	-5		5	μA
	I <sub>IL</sub>					
Setup time	t <sub>S</sub>		4			ns
Hold time	t <sub>H</sub>		1			ns
Propagation delay time	t <sub>PD</sub>			14		ns
Rise time	t <sub>r</sub>			26.5		ns
Fall time	t <sub>f</sub>			26.0		ns

\*1 Full-scale output ratio =  $\left| \frac{\text{Full-scale voltage of channel}}{\text{Average of the full-scale voltage of the channels}} - 1 \right| \times 100 (\%)$

**Electrical Characteristics Measurement Circuit**

Analog Input Resistance  
Digital Input Current

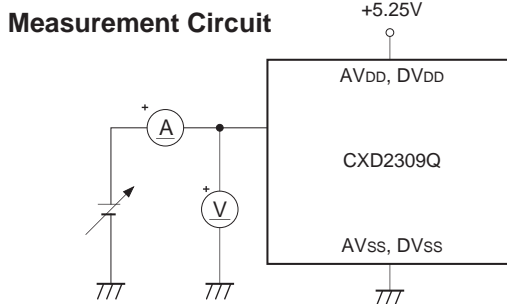

**Conversion Rate Measurement Circuit**

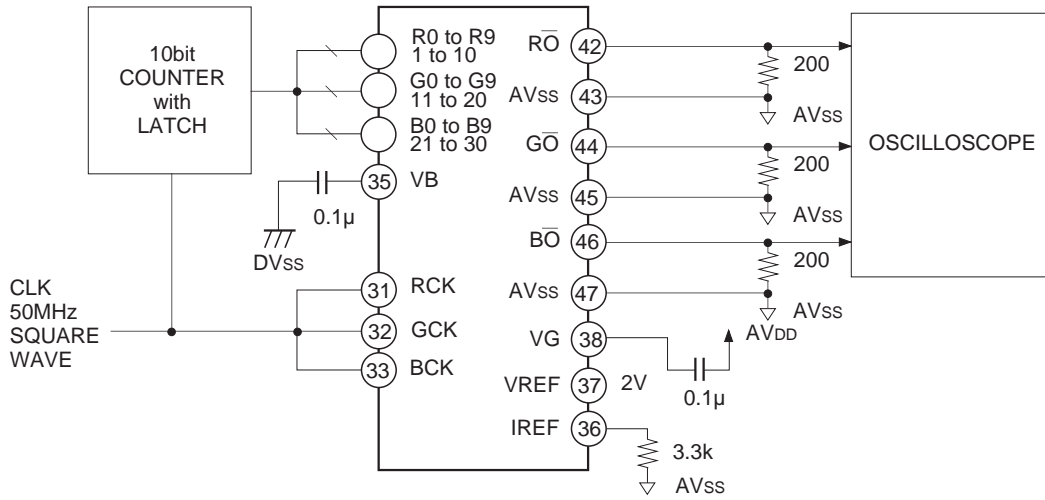

Setup Time  
Hold Time  
Glitch Energy

**Measurement Circuit**

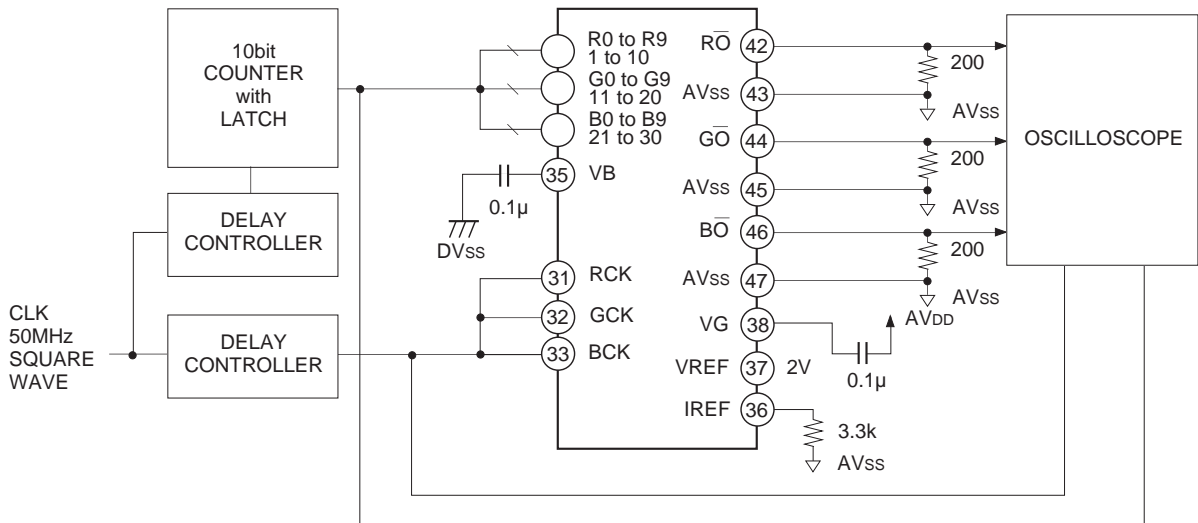

**Crosstalk Measurement Circuit**

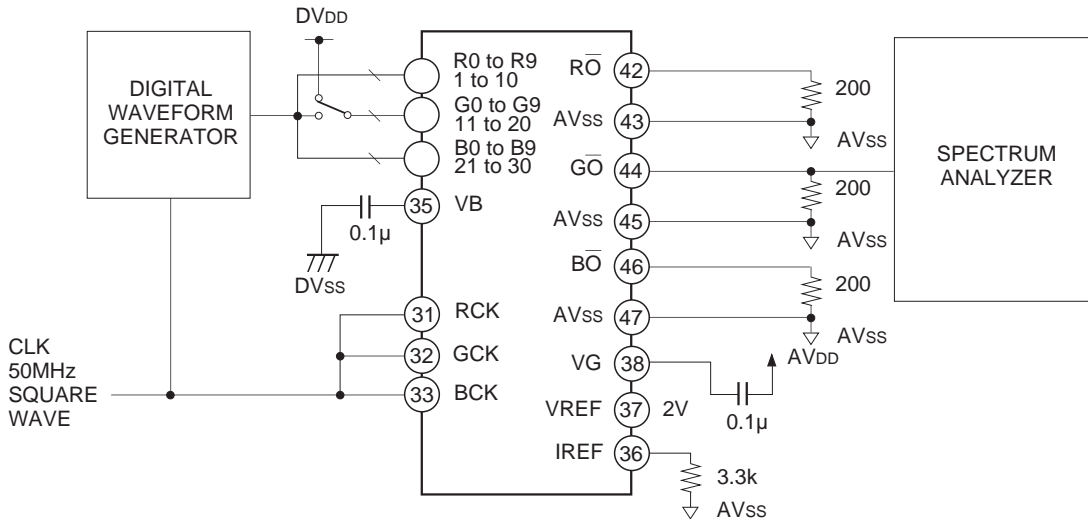

**DC Characteristics Measurement Circuit**

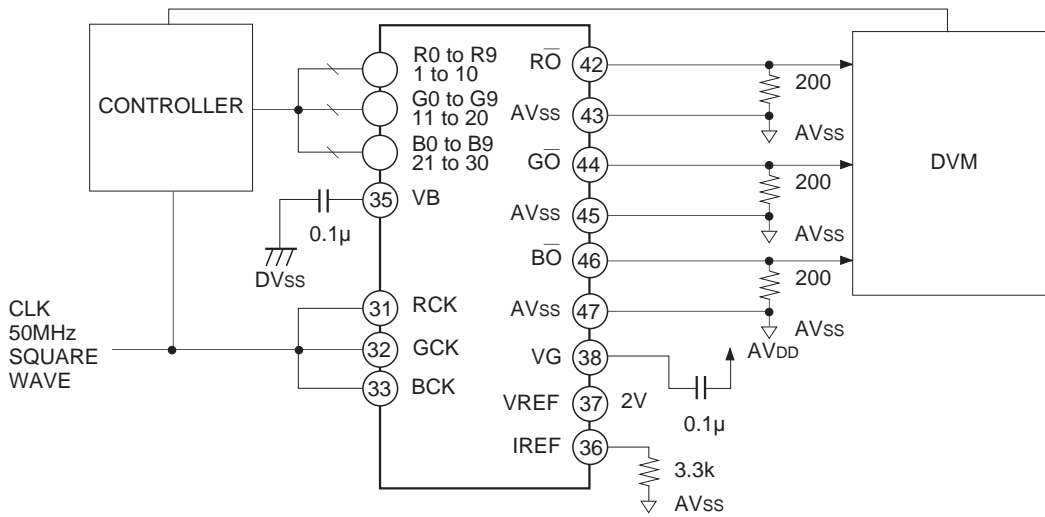

**Propagation Delay Time Measurement Circuit**

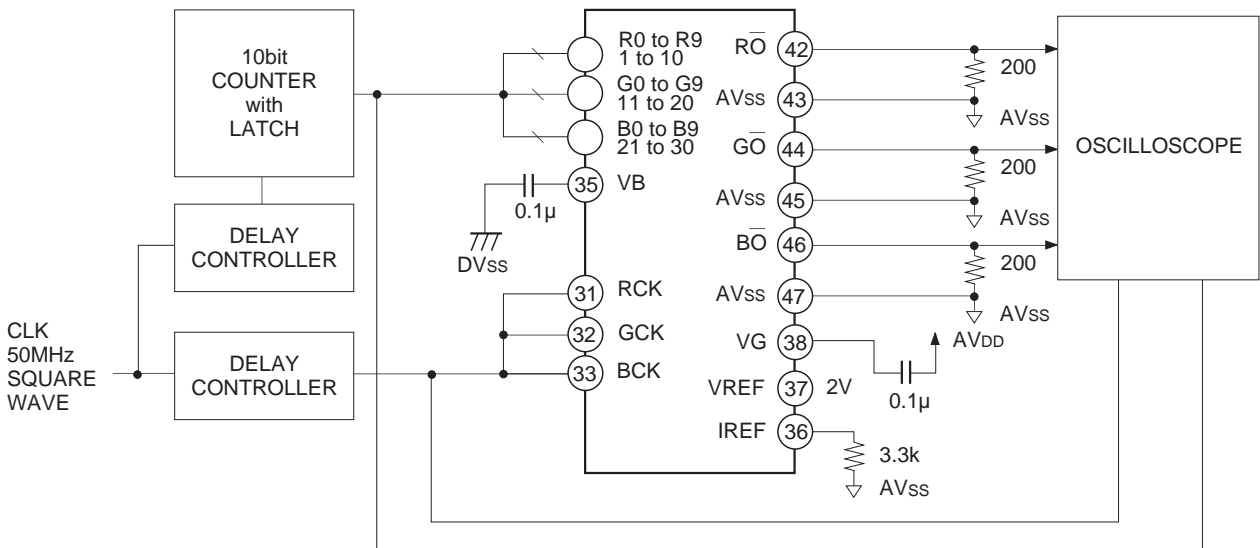

**SNR Measurement Circuit**

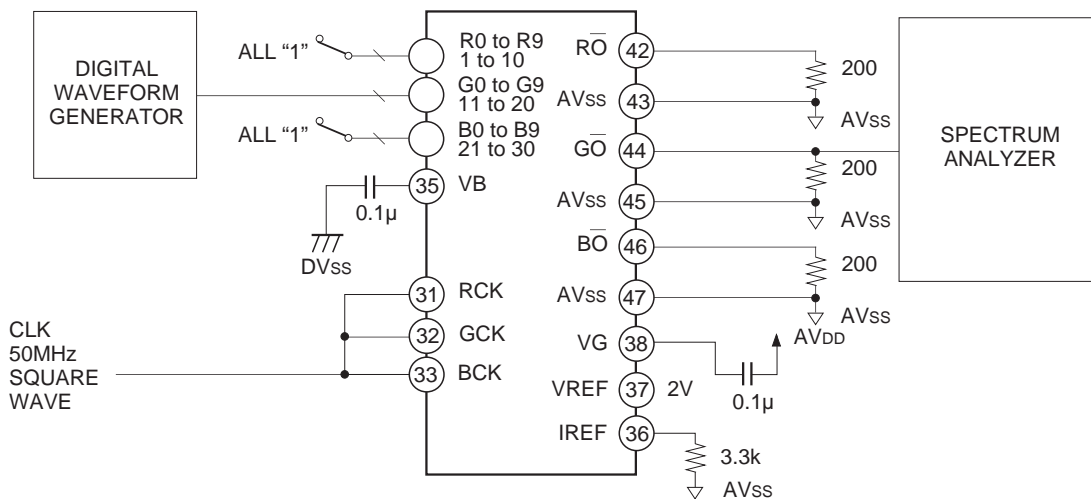

Description of Operation

Timing Chart

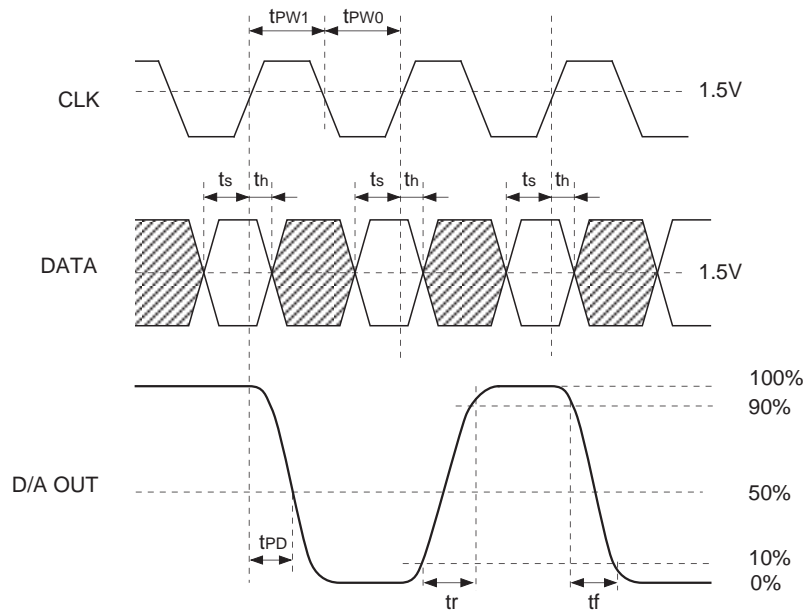

I/O Correspondence Table (output full-scale voltage: 2.00 V)

Input code		Output voltage
MSB	LSB	
1	1 1 1 1 1 1 1 1 1	2.0 V
	:	
1	0 0 0 0 0 0 0 0 0	1.0 V
	:	
0	0 0 0 0 0 0 0 0 0	0 V

## Notes on Operation

- Selecting the Output Resistance

CXD2309Q is a current output type D/A converter. The output voltage can be obtained by connecting the resistor  $R_{OUT}$  to the current output pins  $\overline{RO}$ ,  $\overline{GO}$  and  $\overline{BO}$ .

Specifications: Output full-scale voltage  $V_{FS} = 1.8$  to  $2.0$  [V]

Output full-scale current  $I_{FS} = 9.0$  to  $10.0$  [mA]

Calculate the output resistance from  $V_{FS} = I_{FS} \times R_{OUT}$ . Connect a resistance sixteen times the output resistance to the reference current output pin IREF. In some cases, as this value may not exist, a similar value can be used instead.

Note that the  $V_{FS}$  will be the following.

$$V_{FS} = V_{REF} \times 16R_{OUT}/R_{IR}$$

$V_{REF}$  is the voltage set at the reference voltage input pin  $V_{REF}$ ,  $R_{OUT}$  is the resistor to be connected to the current output pins  $\overline{RO}$ ,  $\overline{GO}$ ,  $\overline{BO}$  and  $R_{IR}$  is the resistor to be connected to the IREF. Power consumption can be reduced by increasing the resistance, but this will on the contrary increase the glitch energy and data setting time. Set the best values according to the purpose of use.

- Correlation between Data and Clock

For CXD2309Q to display the desired performance as a D/A converter, the data transmitted from outside and the clock must be synchronized properly. Adjust the setup time ( $t_s$ ) and hold time ( $t_h$ ) as specified in "Electrical Characteristics".

- Power supply, ground

Separate the analog and digital signals around the device to reduce noise effects. Bypass the power supply pin to each ground with a  $0.1 \mu\text{F}$  ceramics capacitor as near as possible to the pin for both the digital and analog signals.

- Latch up

Analog and digital power supplies must be able to share the same power supply of the board. This is to prevent latch up caused by potential difference between the two pins when the power is turned on.

- IREF

The IREF pin is very sensitive to improve the AC characteristics. Pay attention for capacitance component not to attach to this pin because its output may become unstable.

- VG pin

It is recommended to use a  $1 \mu\text{F}$  capacitor to improve the AC characteristics though the typical capacitance value externally connected to the VG pin is  $0.1 \mu\text{F}$ .

- Output full-scale voltage

For the applications using the RGB signal, the color balance may be broken up when the  $\overline{RO}$ ,  $\overline{GO}$  and  $\overline{BO}$  output full-scale voltages are used with not adjustment.

Application Circuit

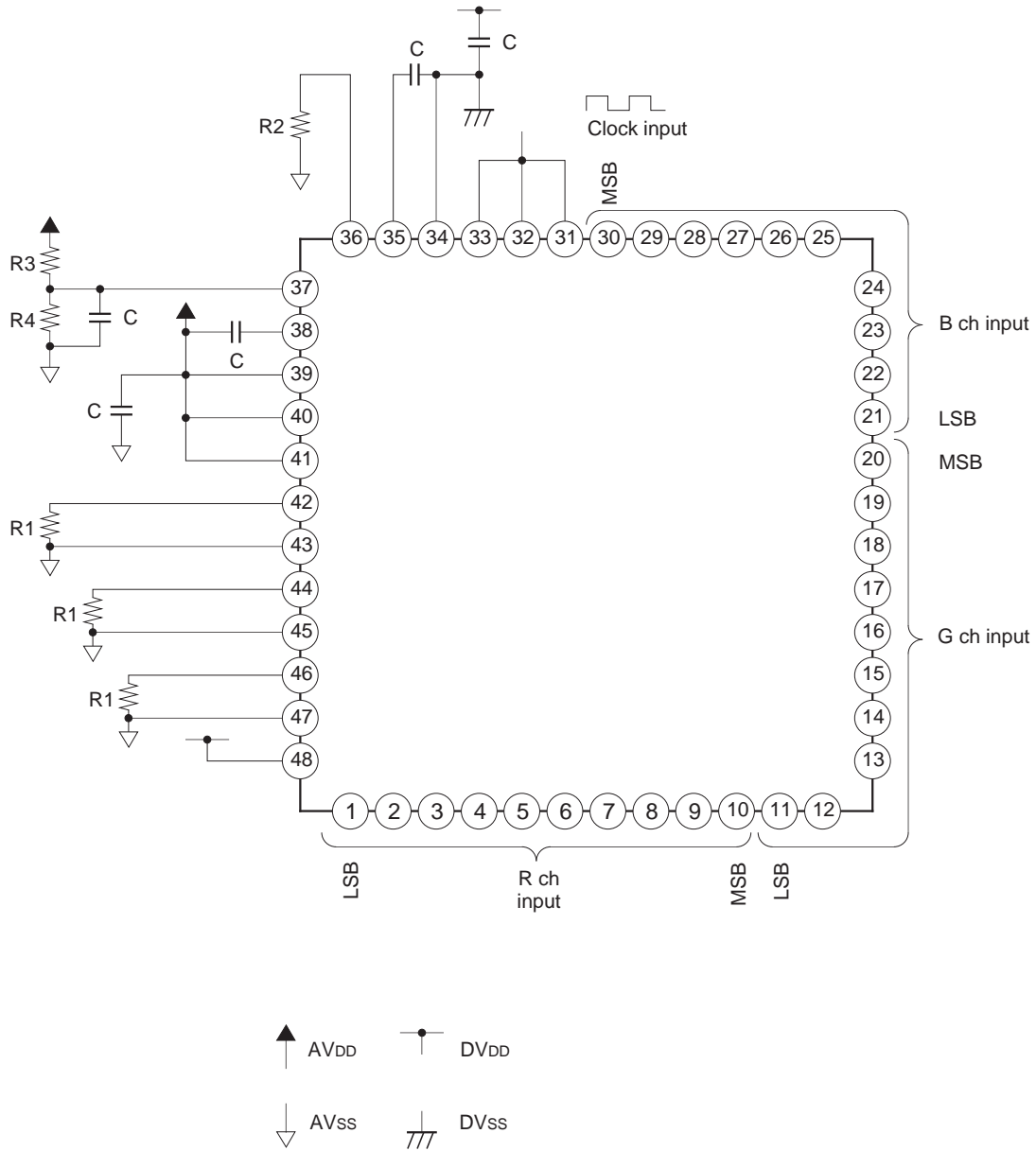

- When the power supply (AVDD and DVDD) is 5.0 V.
- R1=200 Ω
- R2=3.3 kΩ
- R3=3.0 kΩ
- R4=2.0 kΩ
- C=0.1 μF

Application circuits shown are typical examples illustrating the operation of the devices. Sony cannot assume responsibility for any problems arising out of the use of these circuits or for any infringement of third party patent and other right due to same.

**Latch Up Prevention**

The CXD2309Q is a CMOS IC which requires latch up precautions. Latch up is mainly generated by the lag in the voltage rising time of AVDD (Pin 39, 40 and 41) and DVDD (Pin 48), when power supply is ON.

**1. Correct usage**

**a. When analog and digital supplies are from different sources**

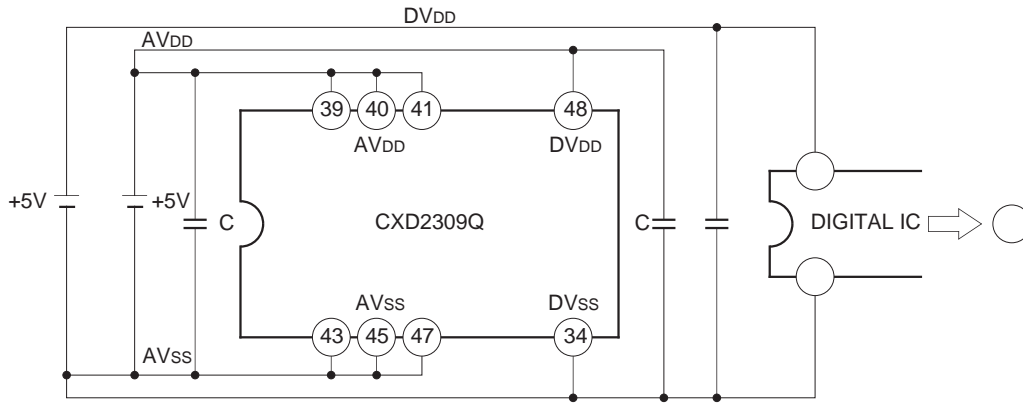

**b. When analog and digital supplies are from a common source**

(i)

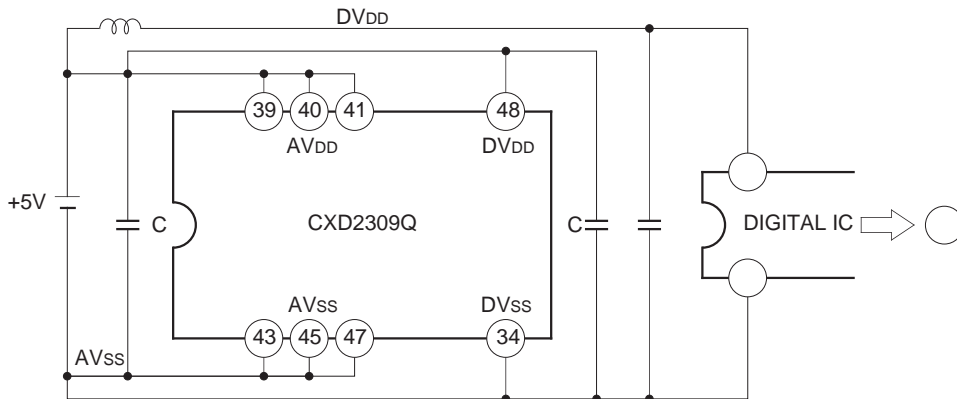

(ii)

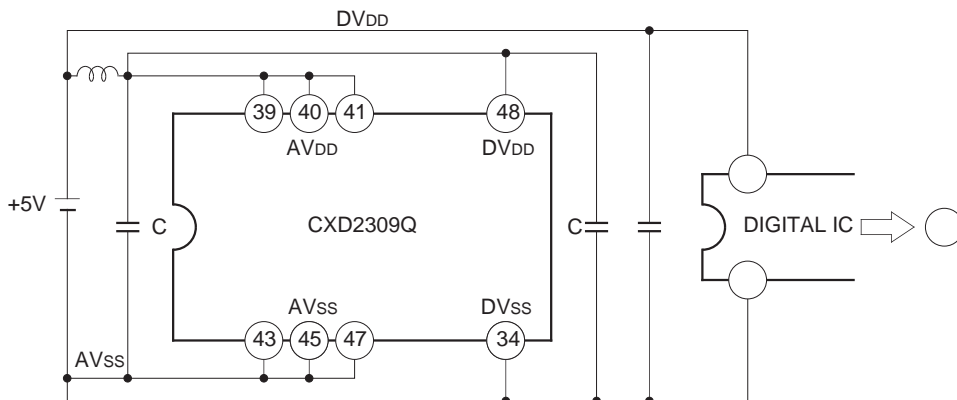

2. Example when latch up easily occurs

a. When analog and digital supplies are from different sources

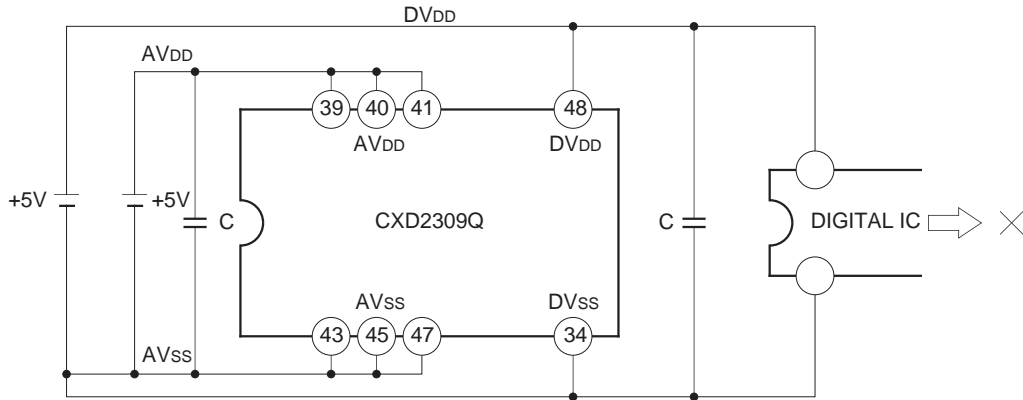

b. When analog and digital supplies are from common source

(i)

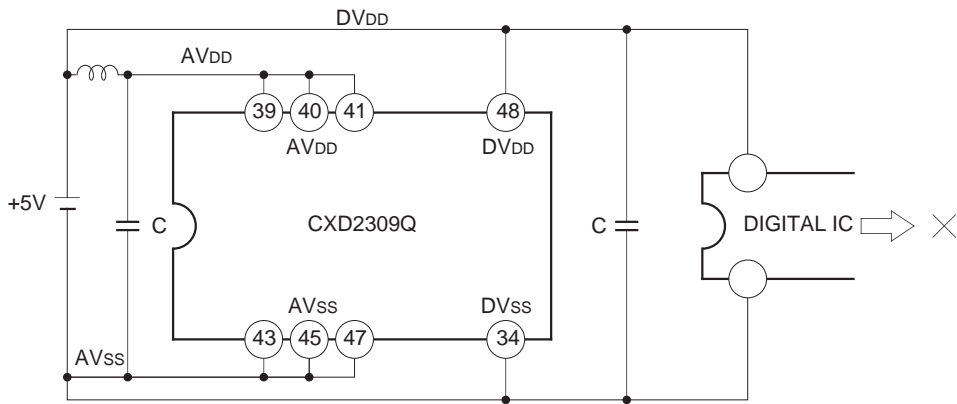

(ii)

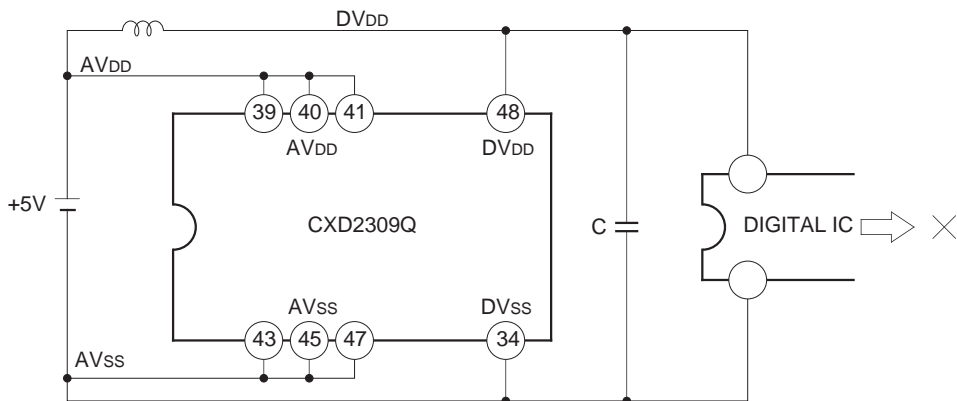

Example of Representative Characteristics

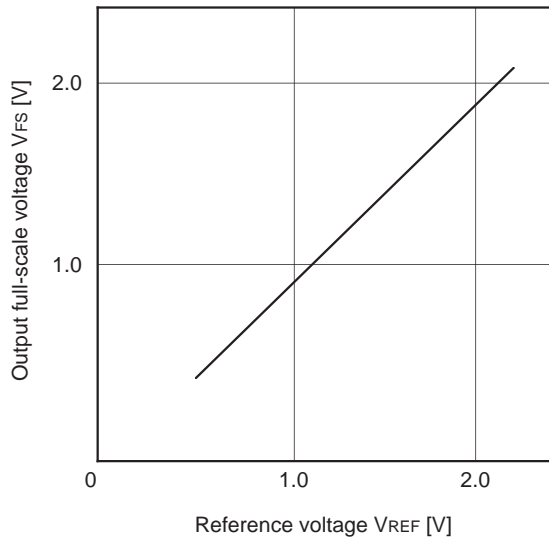

Fig. 1. Reference voltage vs. Output full-scale voltage

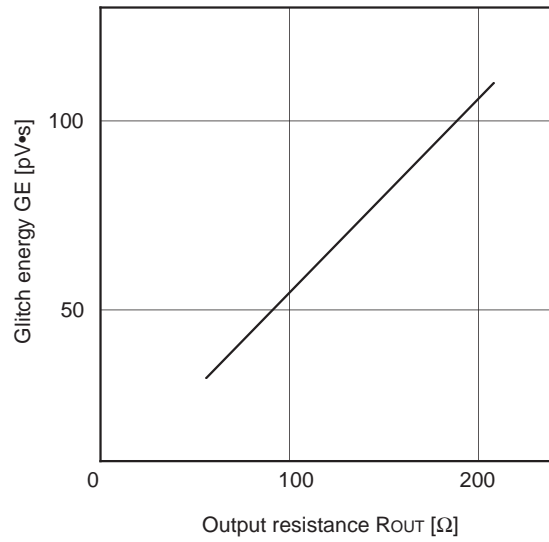

Fig. 2. Output resistance vs. Glitch energy

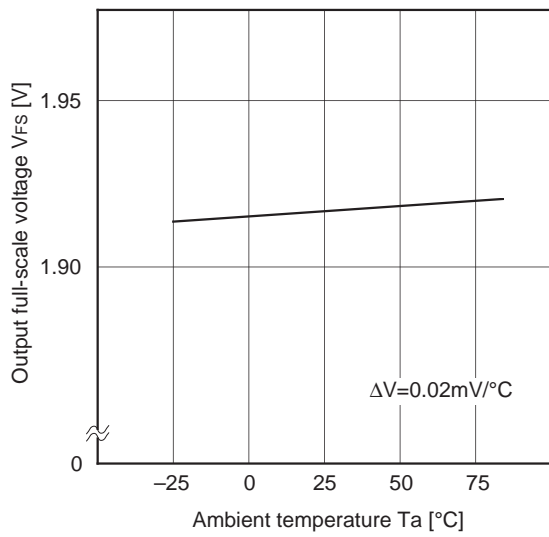

Fig. 3. Ambient temperature vs. Output full-scale voltage

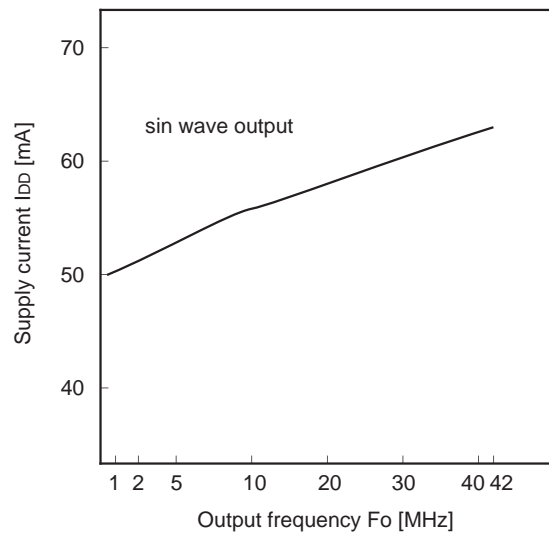

Fig. 4. Output frequency vs. Supply current

Standard Measurement Conditions

- $A_{VDD}=D_{VDD}=5.0$  V
- $V_{REF}=2.0$  V
- $F_{CLK}=85$  MHz
- $R_{OUT}=200$   $\Omega$
- $R_{IR}=3.3$  k $\Omega$
- $T_a=25$   $^{\circ}C$

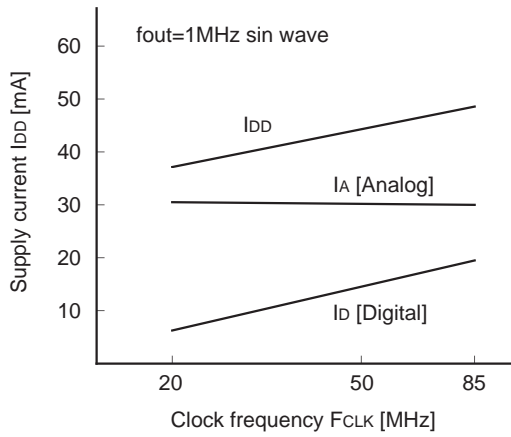

Fig. 5. Clock frequency vs. Supply current

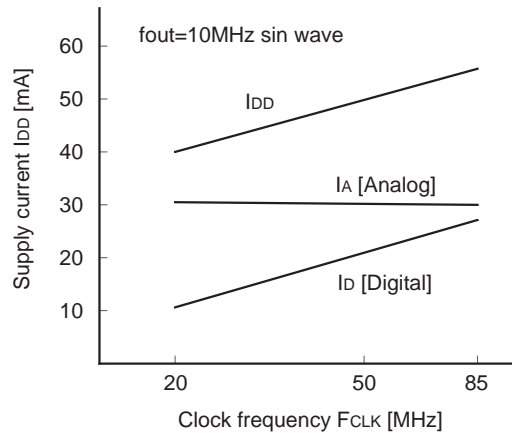

Fig. 6. Clock frequency vs. Supply current

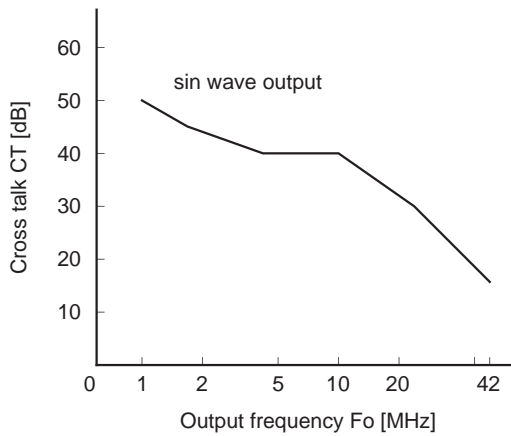

Fig. 7. Output frequency vs. Cross talk

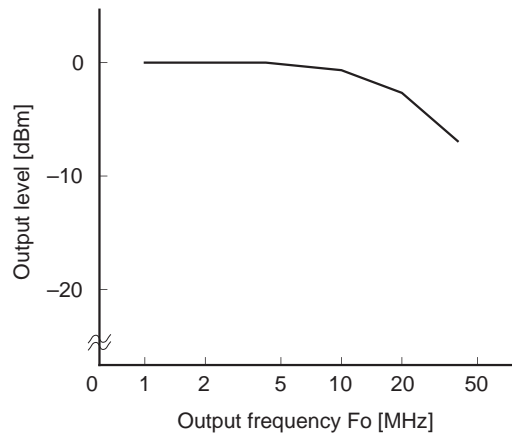

Fig. 8. Output frequency vs. Output level (Including primary hold characteristics sinx/x)

**Standard Measurement Conditions**

- AV<sub>DD</sub>=DV<sub>DD</sub>=5.0 V
- V<sub>REF</sub>=2.0 V
- F<sub>CLK</sub>=85 MHz
- R<sub>OUT</sub>=200 Ω
- R<sub>IR</sub>=3.3 kΩ
- T<sub>a</sub>=25 °C

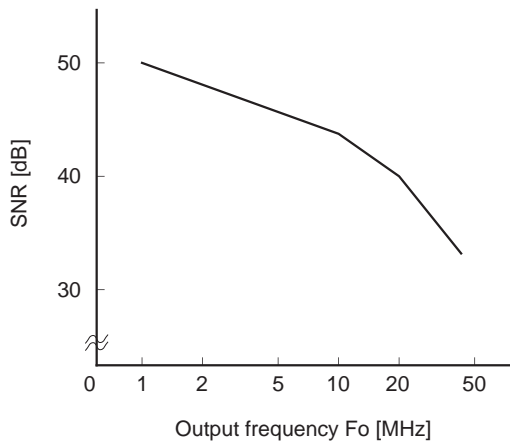

Fig. 9. Output frequency vs. SNR

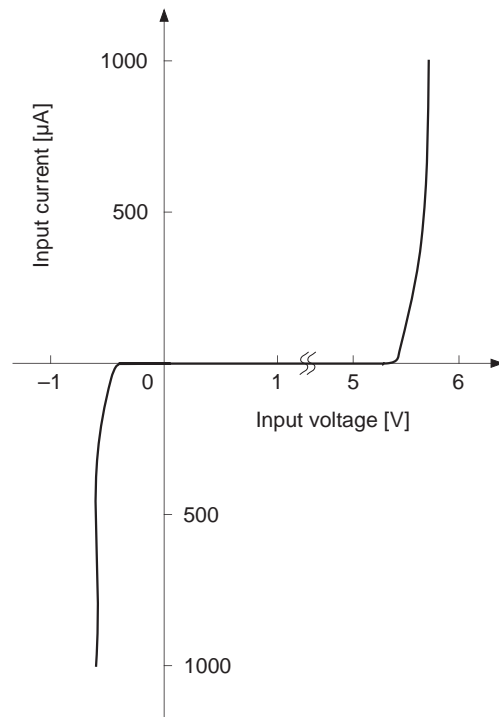

Fig. 10. Input terminal V-I characteristics

**Standard Measurement Conditions**

- $A_{VDD}=D_{VDD}=5.0\text{ V}$
- $V_{REF}=2.0\text{ V}$
- $F_{CLK}=85\text{ MHz}$
- $R_{OUT}=200\ \Omega$
- $R_{IR}=3.3\text{ k}\Omega$
- $T_a=25\text{ }^\circ\text{C}$

Package Outline Unit : mm

48PIN QFP (PLASTIC)

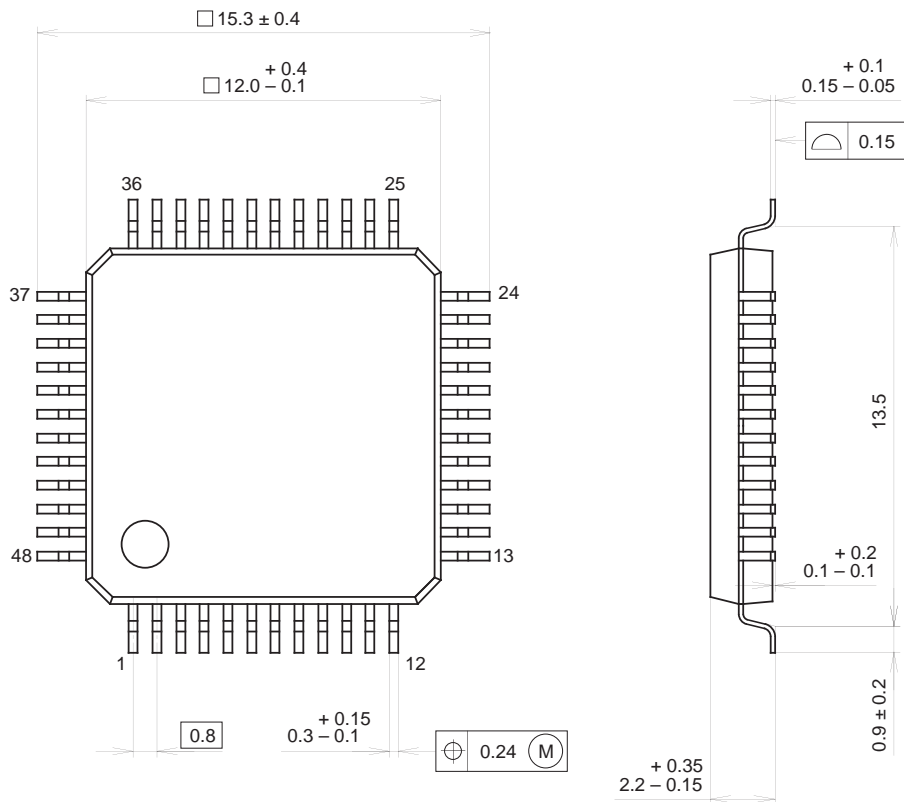

PACKAGE STRUCTURE

SONY CODE	QFP-48P-L04
EIAJ CODE	QFP048-P-1212
JEDEC CODE	_____

PACKAGE MATERIAL	EPOXY RESIN
LEAD TREATMENT	SOLDER / PALLADIUM PLATING
LEAD MATERIAL	42/COPPER ALLOY
PACKAGE MASS	0.7g



LittleDiode supplies new, hard to find or obsolete electronic components and semiconductors all over the world.

With over two million different components listed you are sure to find the part you need.

Feel free to visit us today at our online store:

[LittleDiode.com](http://LittleDiode.com)

Looking forward to providing you with the best possible service.