

8-bit 30MSPS Video A/D Converter with Built-in Amplifier/Clamp

Description

The CXD2301Q is an 8-bit CMOS A/D converter for video applications with built-in amplifier/sync-clamp circuits. A maximum conversion rate of 30MSPS is attained at a low power consumption by adopting a 2-step parallel system.

Features

- Resolution: 8 bits $\pm 1/2$ LSB (DL)
- Maximum sampling frequency: 30MSPS
- Low power consumption: 120mW (at 30MSPS typ.)
(Including reference current)
- Standby function:
0.5mW power consumption in standby
- Amplifier functions: Built-in 3x amplifier (15MHz band),
2-input selector function provided
- Synchronous clamp function
- Clamp ON/OFF function
- Reference voltage self-bias circuit
- TTL compatible output
- 3V digital interface capability
- Single 5V or dual 4.75/3.3V power supplies
- Low input capacitance: 8pF
- Reference impedance: 330 Ω (typ.)

Applications

Wide range of application fields where high-speed A/D conversion is required such as in the digital systems of TVs, VCRs, etc.

Structure

Silicon gate CMOS IC

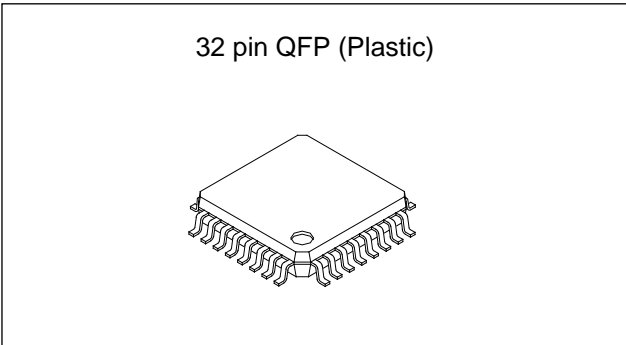

Absolute Maximum Ratings (Ta = 25°C)

- Supply voltage V_{DD} 7 V
- Reference voltage V_{RT}, V_{RB}
 $V_{DD} + 0.5$ to $V_{SS} - 0.5$ V
- Input voltage (analog) V_{IN}
 $V_{DD} + 0.5$ to $V_{SS} - 0.5$ V
- Input voltage (digital) V_{IH}, V_{IL}
 $V_{DD} + 0.5$ to $V_{SS} - 0.5$ V
- Output voltage (digital) V_{OH}, V_{OL}
 $V_{DD} + 0.5$ to $V_{SS} - 0.5$ V
- Storage temperature T_{stg} -55 to +150 °C

Recommended Operating Conditions

- Supply voltage $IDV_{SS} - AV_{SS} I_0$ to 100 mV
- Single power supply AV_{DD}, DV_{DD} 5.0 \pm 0.25 V
- Dual power supply AV_{DD} 4.75 \pm 0.25 V
- DV_{DD} 3.3 \pm 0.3 V
- Reference input voltage V_{RB} 0 to V
- V_{RT} to 2.2 V
- Analog input $ADIN$ More than 1.2Vp-p
- Clock pulse width TP_{WI} 16 (min) ns
- TP_{WO} 16 (min) ns
- Operating ambient temperature $Topr$ -20 to +75 °C

Sony reserves the right to change products and specifications without prior notice. This information does not convey any license by any implication or otherwise under any patents or other right. Application circuits shown, if any, are typical examples illustrating the operation of the devices. Sony cannot assume responsibility for any problems arising out of the use of these circuits.

Block Diagram

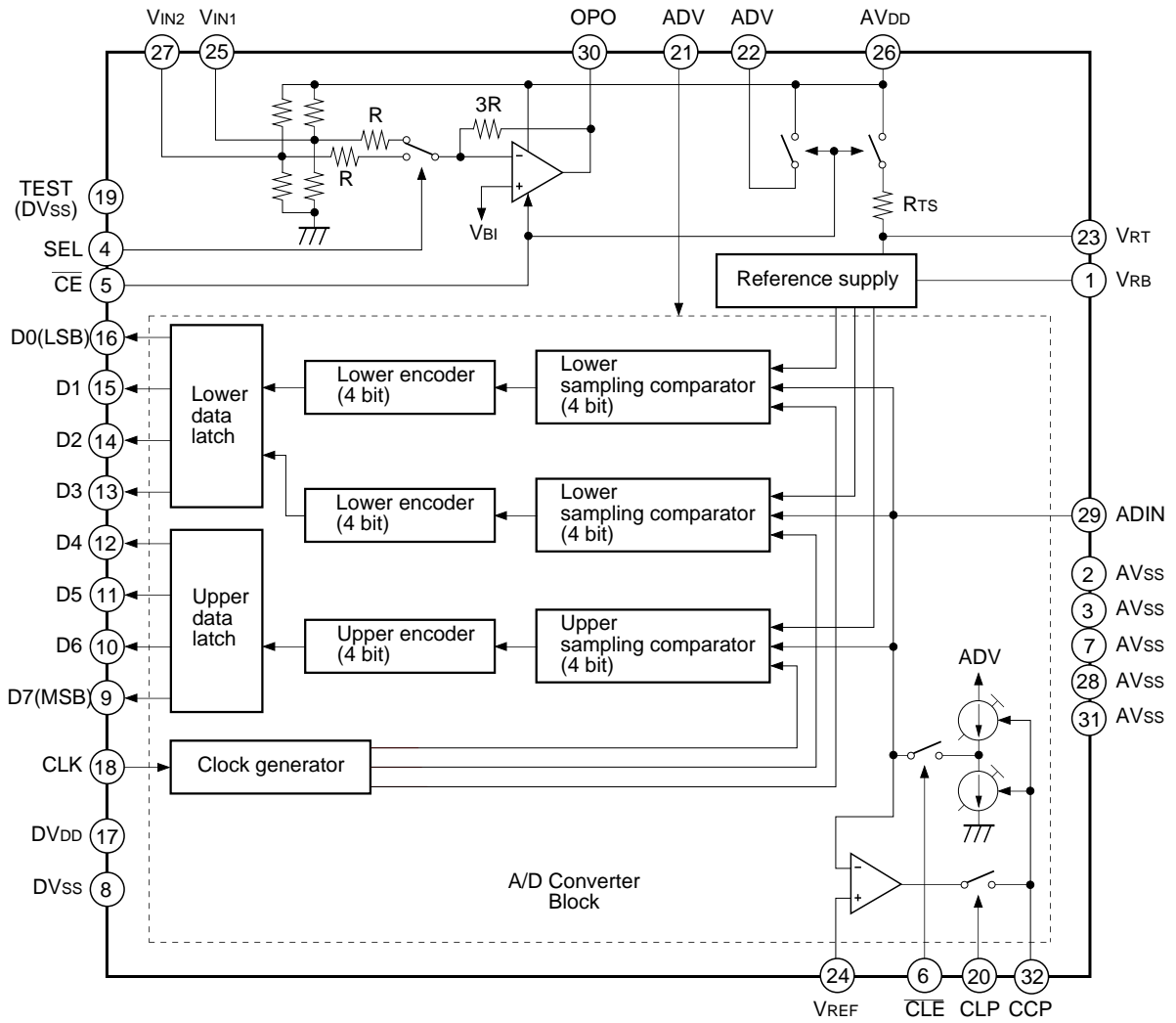

Pin Description

Pin No.	Symbol	Equivalent circuit	Description
1	V _{RB}		Reference voltage (bottom) Connect to AV _{SS} for normal use. When another external voltage is input, connect an external 0.1μF capacitor and retain a 1.5V differential compared to the top reference voltage.
23	V _{RT}		Reference voltage (top) By setting V _{RB} to AV _{SS} , outputs approximately 1.5V. Connect only a 0.1μF external by-pass capacitor for normal use. When another external voltage is input, it must be 2.2V or lower.
2, 3, 7, 28, 31	AV _{SS}		Analog GND.
4	SEL		Switches the input of the 3x amplifier. When SEL is at Low level, V _{IN1} is selected. When SEL is at High level, V _{IN2} is selected.
5	$\overline{\text{CE}}$		Standby function ON/OFF selector. In standby state when High.
19	TEST		Fix to V _{SS} for normal use.
6	$\overline{\text{CLE}}$		When $\overline{\text{CLE}}$ = Low: Clamp function is enabled. When $\overline{\text{CLE}}$ = High: Clamp function is disabled, and only the normal A/D converter function is enabled.
18	CLK		Clock input
20	CLP		Inputs the clamp pulse to Pin 20 (CLP). Clamps the High interval signal voltage.
8	DV _{SS}		Digital GND.
9 to 16	D ₇ to D ₀		D ₇ (MSB) to D ₀ (LSB) output Outputs Low level in standby. In operation, the phase of D ₇ to D ₀ output is inverted against the phase of ADIN.
17	DV _{DD}		5V or 3.3V

Pin No.	Symbol	Equivalent circuit	Description
21	ADV		Short Pins 21 and 22, and connect 0.1μF external capacitor.
22	ADV		
24	VREF		Clamp reference voltage input. Clamps so that the reference voltage and the clamp interval ADIN input signal are equal. The reference voltage is more than 0.5V.
25 27	V _{IN1} V _{IN2}		Amplifier input pin. Biased internally at 1.9V (when AV _{DD} = 5V) or at 1.8V (when AV _{DD} = 4.75V). When in standby as well. When SEL is at Low level, V _{IN1} is selected for input; When SEL is at High level, V _{IN2} is selected for input.
26	AV _{DD}		5V or 4.75V

Pin No.	Symbol	Equivalent circuit	Description
29	ADIN		A/D converter block analog input.
30	OPO		<p>Amplifier output.</p> <p>The phase of this output is inverted against the phase of $V_{IN1, 2}$.</p> <p>In standby mode, it becomes high-impedance output condition.</p>
32	CCP		<p>Integrates the clamp control voltage.</p> <p>The relationship between the CCP voltage variation and the ADIN voltage is positive phase.</p>

- The following table shows the status of the digital output pins when the TEST pin is used with the \overline{CE} and SEL pins.

TEST	\overline{CE}	SEL	D1	D2	D3	D4	D5	D6	D7	D8
L	L	X	D1	D2	D3	D4	D5	D6	D7	D8
L	H	X	L	L	L	L	L	L	L	L
H	L	X	← TEST mode →							
H	H	L	H	L	H	L	H	L	H	L
H	H	H	L	H	L	H	L	H	L	H

Digital Output

The following table shows the correlation between the ADIN input voltage and the digital output code. Take notice that the phase of ADIN input signal voltage is inverted against the phase of the digital output.

ADIN Input signal voltage	Step	Digital output code							
		MSB				LSB			
V _{RT}	0	0	0	0	0	0	0	0	0
⋮	⋮					⋮			
⋮	127	0	1	1	1	1	1	1	1
⋮	128	1	0	0	0	0	0	0	0
⋮	⋮					⋮			
V _{RB}	255	1	1	1	1	1	1	1	1

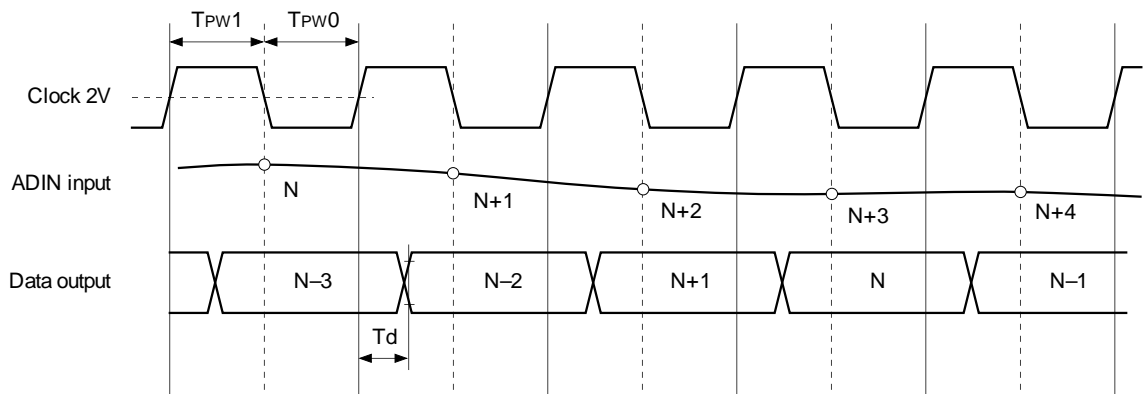

○ : Indicates point at which input signal is sampled

Fig. 1. Timing Chart

Electrical Characteristics

(1) When using a single power supply ($F_c = 30\text{MSPS}$, $A_{VDD} = DV_{DD} = +5\text{V}$, $V_{RB} = 0\text{V}$, $V_{RT} = 1.5\text{V}$, $T_a = 25^\circ\text{C}$)

Item	Symbol	Conditions		Min.	Typ.	Max.	Unit
Supply current	$I_{AD} + I_{DD}$	$F_c = 35\text{MSPS}$ NTSC ramp wave input			27	35	mA
Standby supply current	I_{STB}	$\overline{CE} = DV_{DD}$			130	200	μA
Max. conversion rate	$F_c \text{ max}$	$V_{IN} = 0 \text{ to } 1.5\text{V}$ $f_{IN} = 1\text{kHz ramp}$		30			MSPS
Min. conversion rate	$F_c \text{ min}$					0.5	
ADIN input band (at -1dB)	BW				20		MHz
ADIN input capacitance	C_{ADIN}	$V_{IN} = 0.75\text{V} + 0.07\text{V}_{\text{rms}}$			8		pF
Reference resistance (V_{RT} to V_{RB})	R_{REF}			230	330	440	Ω
Self bias	V_{RT}	$V_{RB} = AV_{SS}$		1.38	1.52	1.66	V
Offset voltage	E_{OT}			-40	-20	0	mV
	E_{OB}			+25	+45	+65	
Digital input voltage	V_{IH}			3.5			V
	V_{IL}					0.5	
Digital input current	I_{IH}	$DV_{DD} = \text{max.}$	$V_{IH} = V_{DD}$			5	μA
	I_{IL}		$V_{IL} = 0\text{V}$			5	
Digital output current	I_{OH}	$DV_{DD} = \text{min.}$	$V_{OH} = V_{DD} - 0.5\text{V}$	-1.1	-2.5		mA
	I_{OL}		$V_{OL} = 0.4\text{V}$	3.7	6.5		
Output data delay	T_{DL}	With TTL 1gate and 10pF load		7	13	25	ns
Integral nonlinearity error	E_L	$F_c = 30\text{MSPS}$ $V_{IN} = 0 \text{ to } 1.5\text{V}$			+0.5	+1.3	LSB
Differential nonlinearity error	E_D	$F_c = 30\text{MSPS}$ $V_{IN} = 0 \text{ to } 1.5\text{V}$			± 0.3	± 0.5	LSB
Differential gain error	DG	NTSC 40IRE mod ramp, $F_c = 14.3\text{MSPS}$			1		%
Differential phase error	DP				0.5		deg
Aperture jitter	t_{aj}				30		ps
Sampling delay	t_{sd}				2		ns
Clamp offset voltage	E_{oc}	$V_{ADIN} = \text{DC},$ $PWS = 3\mu\text{sec}$	$V_{REF} = 0.5\text{V}$	0	+20	+40	mV
			$V_{REF} = 1.5\text{V}$	-40	-20	0	
Clamp pulse delay	t_{cpd}				25		ns
Amplifier gain		DC to 15MHz		8.5	9.5	10.5	dB
V_{IN1} and V_{IN2} bias voltage	$V_{BI1,2}$	When open			1.9		V
V_{IN1} and V_{IN2} input resistance	$R_{I1,2}$			19	27	35	k Ω
V_{IN1} and V_{IN2} input capacitance	$C_{I1,2}$				15		pF

(2) When using a dual power supply ($F_c = 30\text{MSPS}$, $A_{VDD} = 4.75\text{V}$, $D_{VDD} = 3.3\text{V}$, $V_{RB} = 0\text{V}$, $V_{RT} = 1.5\text{V}$, $T_a = 25^\circ\text{C}$)

Item	Symbol	Conditions		Min.	Typ.	Max.	Unit
Analog supply current	I_{AD}	$F_c = 30\text{MSPS}$ NTSC ramp wave input			24	32	mA
Digital supply current	I_{DD}	$F_c = 30\text{MSPS}$ NTSC ramp wave input			1	2	mA
Standby supply current	I_{STB}	$\overline{CE} = D_{VDD}$			130	200	μA
Max. conversion rate	$F_c \text{ max}$	$V_{IN} = 0 \text{ to } 1.5\text{V}$ $f_{IN} = 1\text{kHz ramp}$		30			MSPS
Min. conversion rate	$F_c \text{ min}$					0.5	
ADIN input band (at -1dB)	BW				20		MHz
ADIN input capacitance	C_{ADIN}	$V_{IN} = 0.75\text{V} + 0.07\text{V}_{rms}$			8		pF
Reference resistance (V_{RT} to V_{RB})	R_{REF}			230	330	440	Ω
Self bias	V_{RT}	$V_{RB} = A_{VSS}$		1.44	1.52	1.6	V
Offset voltage	E_{OT}			-40	-20	0	mV
	E_{OB}			+25	+45	+65	
Digital input voltage	V_{IH}			2.5			V
	V_{IL}					0.5	
Digital input current	I_{IH}	$D_{VDD} = \text{max.}$	$V_{IH} = D_{VDD}$			5	μA
	I_{IL}		$V_{IL} = 0\text{V}$			5	
Digital output current	I_{OH}	$D_{VDD} = \text{min.}$	$V_{OH} = V_{DD} - 0.5\text{V}$	-1.1	-2.5		mA
	I_{OL}		$V_{OL} = 0.4\text{V}$	3.7	6.5		
Output data delay	T_{DL}	With TTL 1gate and 10pF load		7	13	25	ns
Integral nonlinearity error	E_L	$F_c = 30\text{MSPS}$ $V_{IN} = 0 \text{ to } 1.5\text{V}$			+0.5	+1.3	LSB
Differential nonlinearity error	E_D	$F_c = 30\text{MSPS}$ $V_{IN} = 0 \text{ to } 1.5\text{V}$			± 0.3	± 0.5	LSB
Differential gain error	DG	NTSC 40IRE mod ramp, $F_c = 14.3\text{MSPS}$			1		%
Differential phase error	DP				0.5		deg
Aperture jitter	t_{aj}				30		ps
Sampling delay	t_{sd}				2		ns
Clamp offset voltage	E_{oc}	$V_{IN} = \text{DC},$ $PWS = 3\mu\text{sec}$	$V_{REF} = 0.5\text{V}$	0	+20	+40	mV
			$V_{REF} = 1.5\text{V}$	-40	-20	0	
Clamp pulse delay	t_{cpd}				25		ns
3x amplifier gain		DC to 15MHz		8.5	9.5	10.5	dB
V_{IN1} and V_{IN2} bias voltage	$V_{BI,2}$	When open			1.8		V
V_{IN1} and V_{IN2} input resistance	$R_{I1,2}$			19	27	35	k Ω
V_{IN1} and V_{IN2} input capacitance	$C_{I1,2}$				15		pF

Application Circuit

(1) When using the internal amplifier

a) Clamp usage example (using self bias)

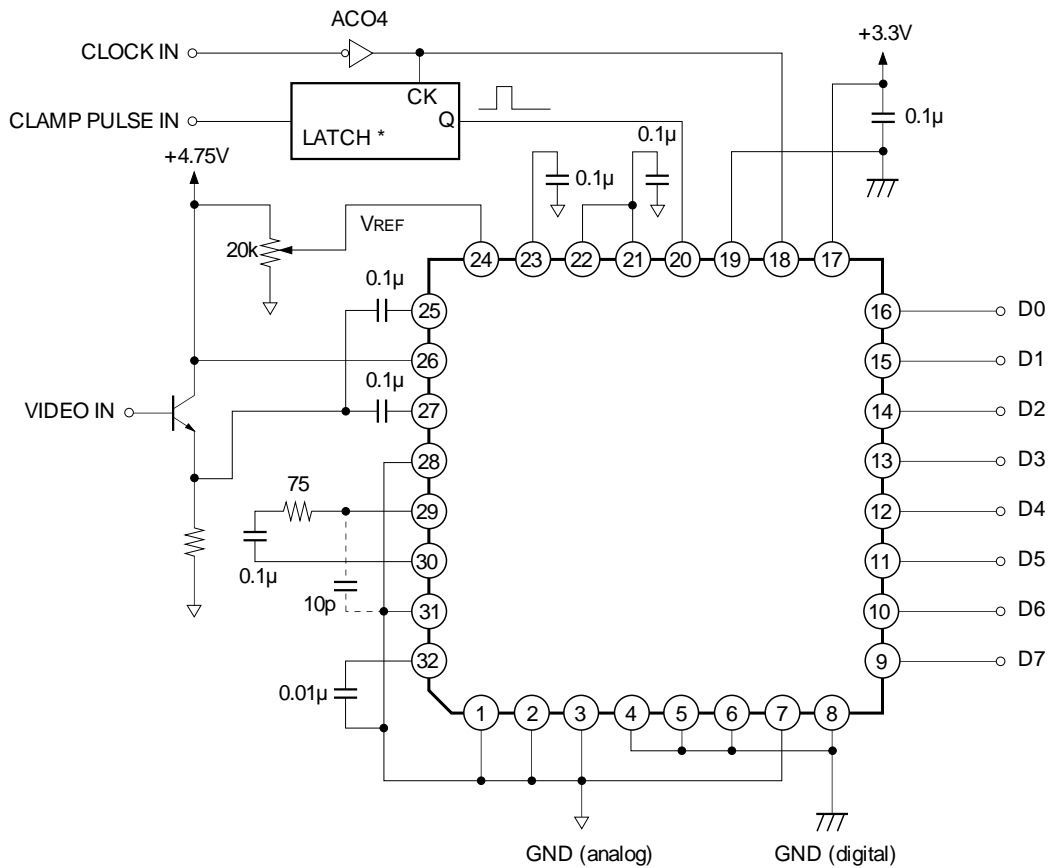

* Although the ADC sampling clock latches the clamp pulse, it is not needed for basic clamp operation. However, depending on the relationship between the sampling frequency and the clamp pulse frequency, a small beat might be generated as V sag. The latch circuit is valid at this time.

b) Digital clamp usage example (using self bias)

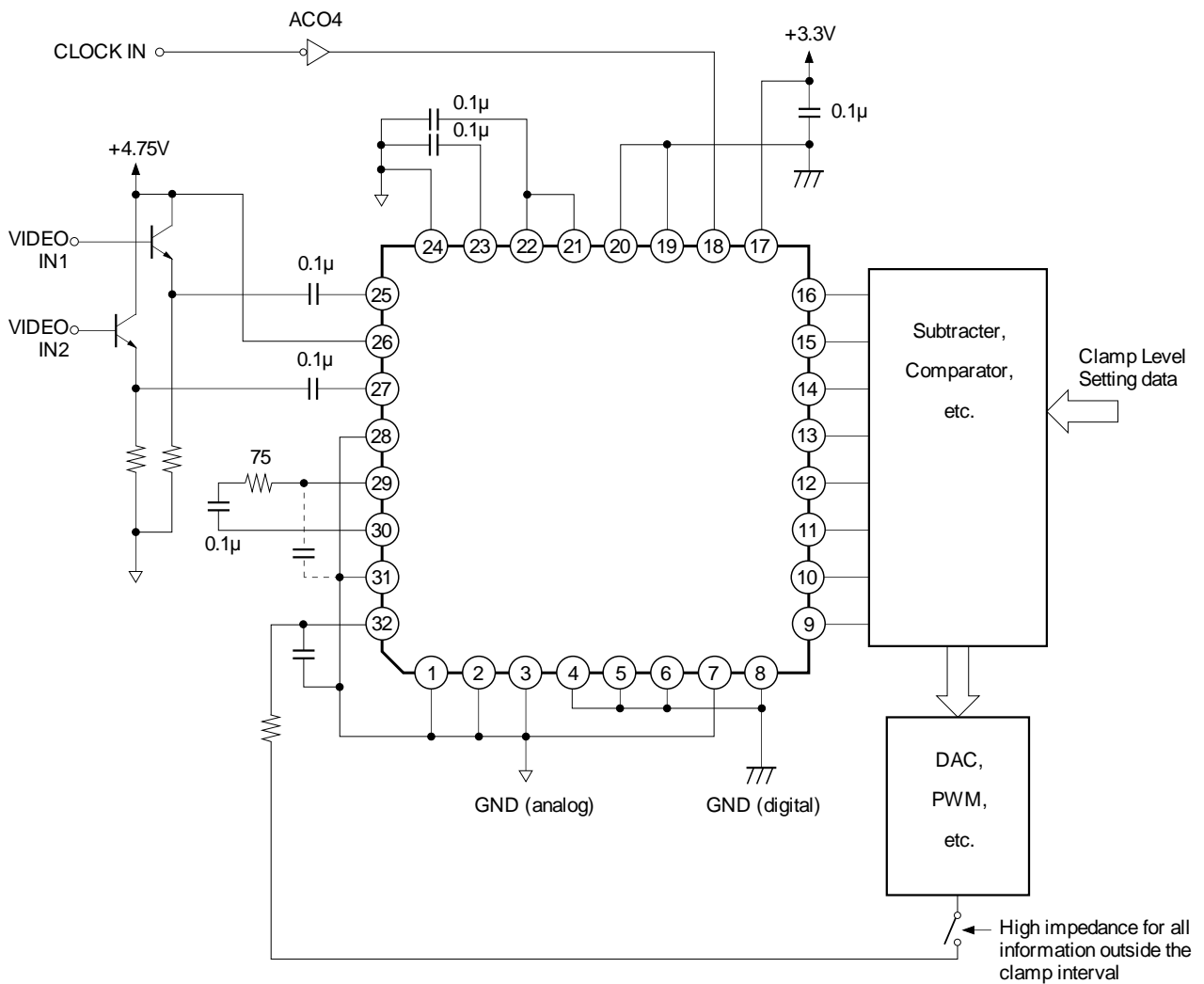

- * The relationship between the CCP voltage (Pin 32) variation and the ADIN voltage variation is positive phase.
- * $\Delta ADIN / \Delta V_{CCP} = 3.0$ ($f_s = 30\text{MSPS}$)

c) When not using the clamp

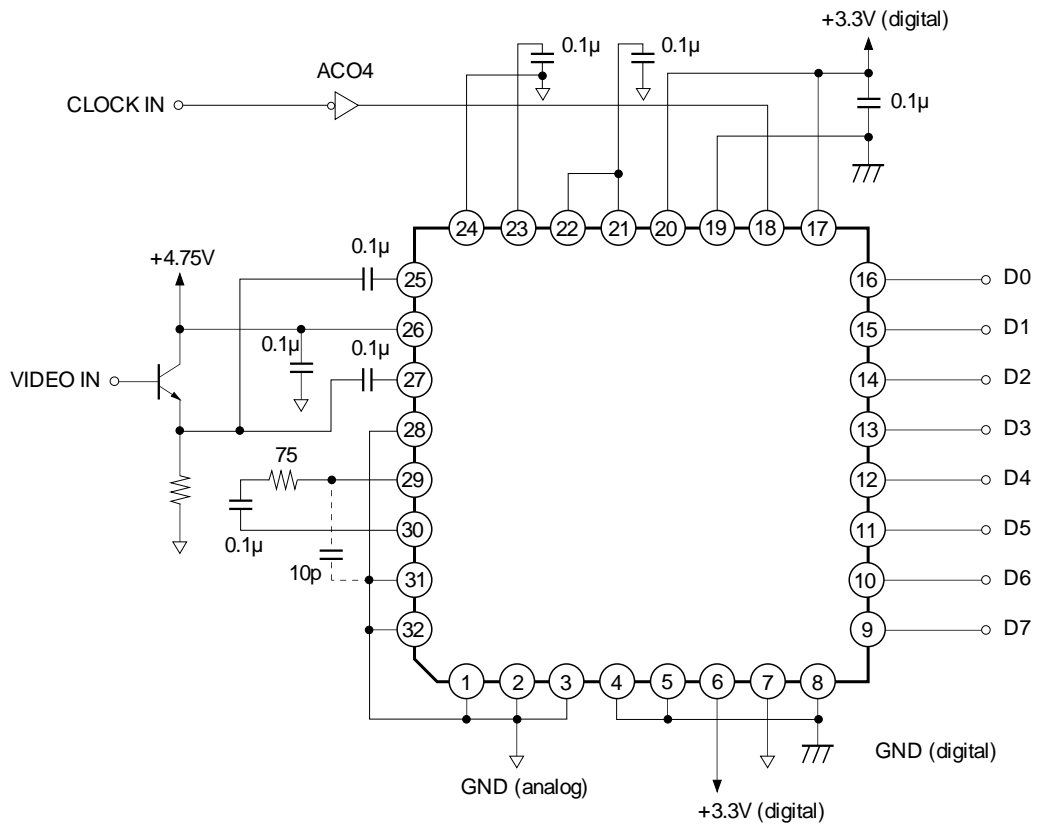

(2) When not using the internal amplifier

a) Clamp usage example

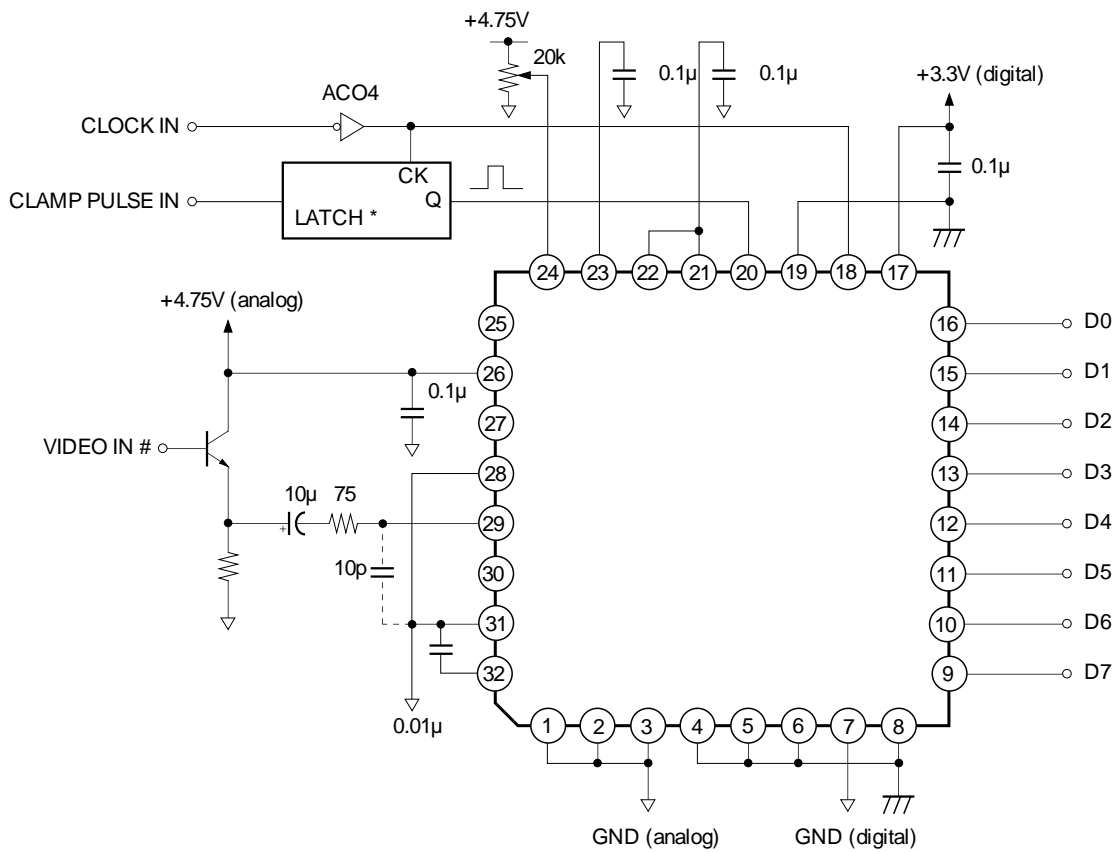

* Although the ADC sampling clock latches the clamp pulse, it is not needed for basic clamp operation. However, depending on the relationship between the sampling frequency and the clamp pulse frequency, a small beat might be generated as V sag. The latch circuit is valid at this time.

Take care that the phase of ADIN input is inverted against the phase of the digital output, because the use of the built-in inverting amplifier is standard. (Refer to "Digital Output" on page 6.)

Example of Representative Characteristics

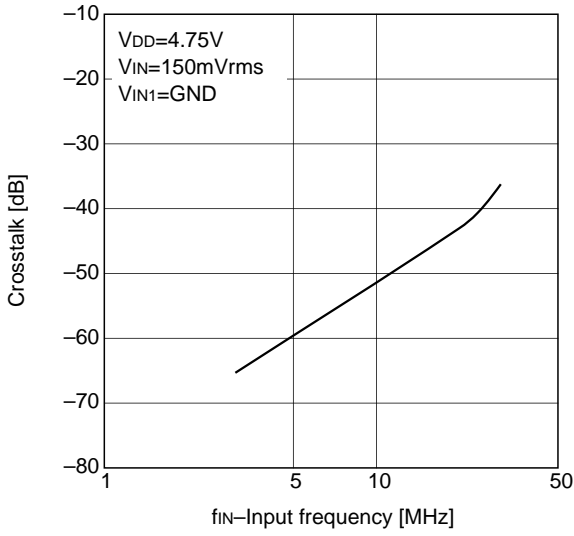

Input frequency of VIN2 vs. Crosstalk VIN2→VIN1

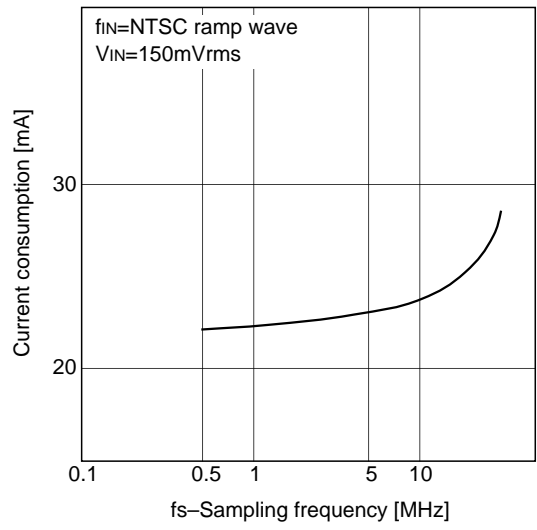

Sampling frequency vs. Current consumption

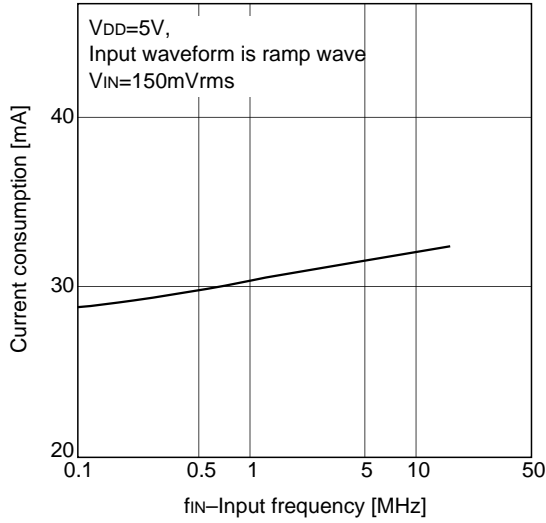

Input frequency vs. Current consumption

8bit ADC and DAC Evaluation Board

Evaluation boards are available for the high speed, low power consumption CMOS converters, CXD2301Q (8-bit 30MHz A/D) and CXD1171M (8-bit 40MHz D/A).

The evaluation board is composed of a main board common to either type, to which is added sub board D2301Q or sub board D1171M. The junction is made through a socket.

To the main board are mounted an input interface, clock buffer and latch. To each of the sub boards is mounted CXD2301Q and CXD1171M respectively. Those IC's are mounted according to recommended print patterns designed to provide maximum performance to the A/D and D/A converters.

Block Diagram

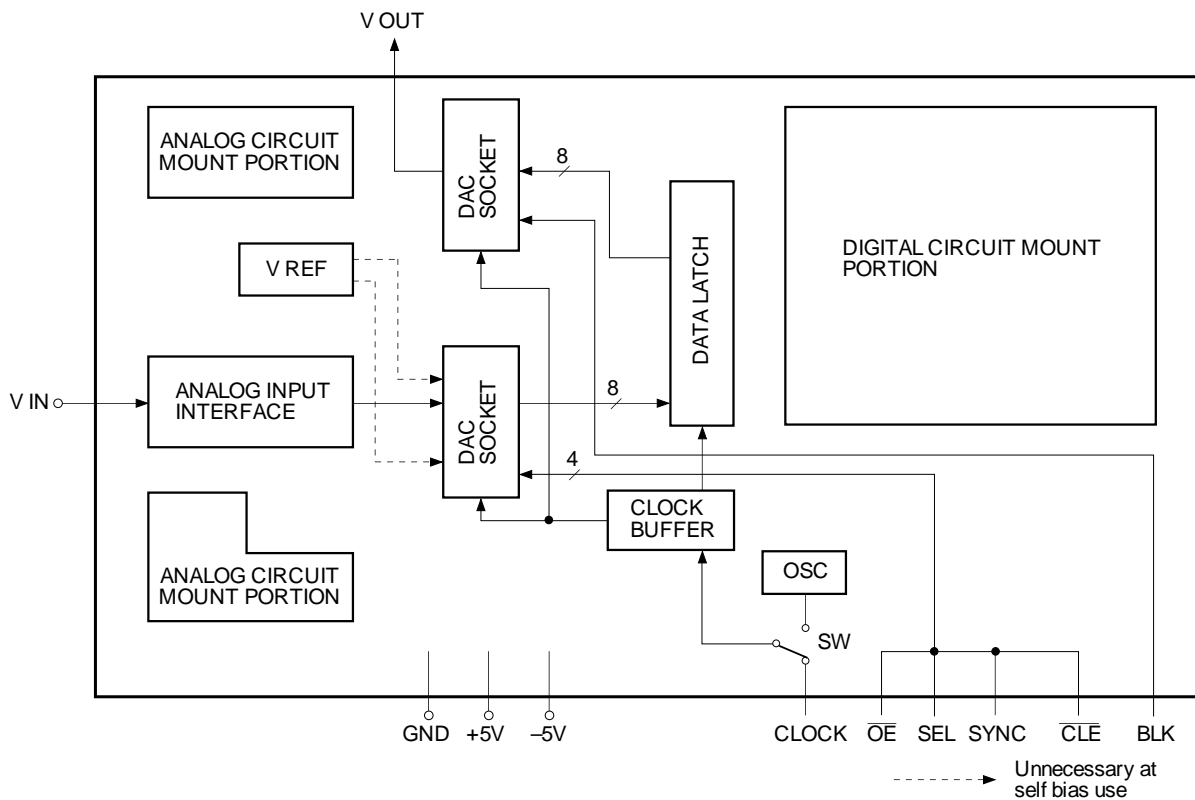

Characteristics

- Resolution 8bit
- Maximum conversion rate 30MHz
- Digital input level CMOS level
- Supply voltage ±5.0V (Single +5V power supply possible at self bias use)

Supply Voltage

Item	Min.	Typ.	Max.	Unit
+5V			165	mA
-5V			20	

Clock Input

CMOS compatible

Pulse width	T _{CW1}	16ns (min)
	T _{CW0}	16ns (min)

Analog Output (CXD1171M) (RL > 10kΩ)

Item	Min.	Typ.	Max.	Unit
Analog output	1.8	2.0	2.1	V

Output Format (CXD2301Q)

The table shows the output format of AD Converter

Analog input voltage	Step	Digital output code							
		MSB				LSB			
V _{RT}	0	0	0	0	0	0	0	0	0
⋮	⋮	⋮							
⋮	127	0	1	1	1	1	1	1	1
⋮	128	1	0	0	0	0	0	0	0
⋮	⋮	⋮							
V _{RB}	255	1	1	1	1	1	1	1	1

Timing Chart

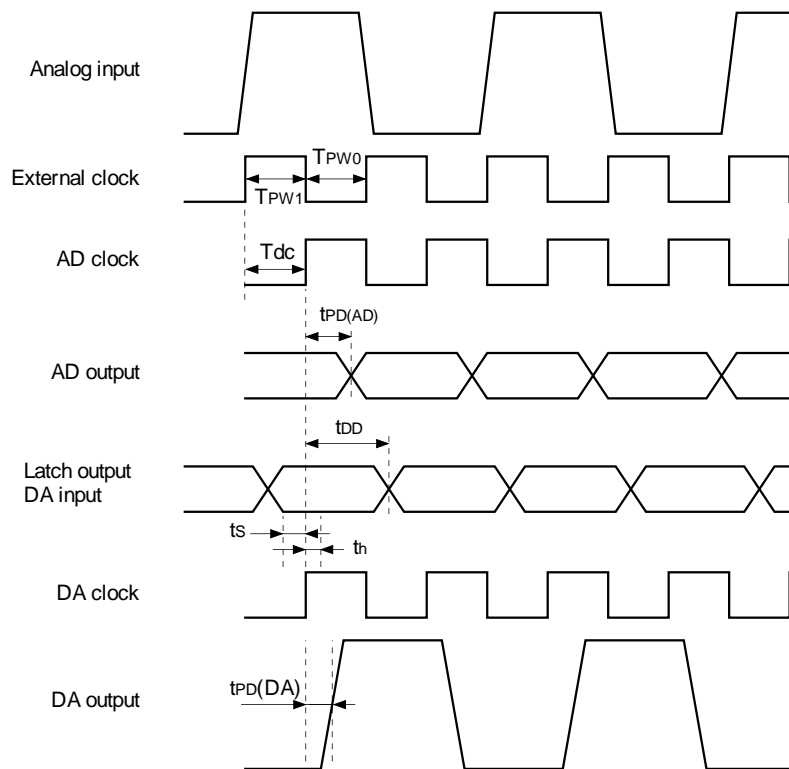

Item	Symbol	Min.	Typ.	Max.	Unit
Clock High time	TPW1	16			ns
Clock Low time	TPW0	16			ns
Clock Delay	Tdc			24	ns
Data delay AD	t _{PD (AD)}		13	25	ns
Data delay (latch)	t _{DD}			5	ns
Settling time	ts	5			ns
Hold time	th	10			ns
Data delay DA	t _{PD (DA)}		10		ns

CMOS ADC/DAC Peripheral Circuit Board (Main Board)

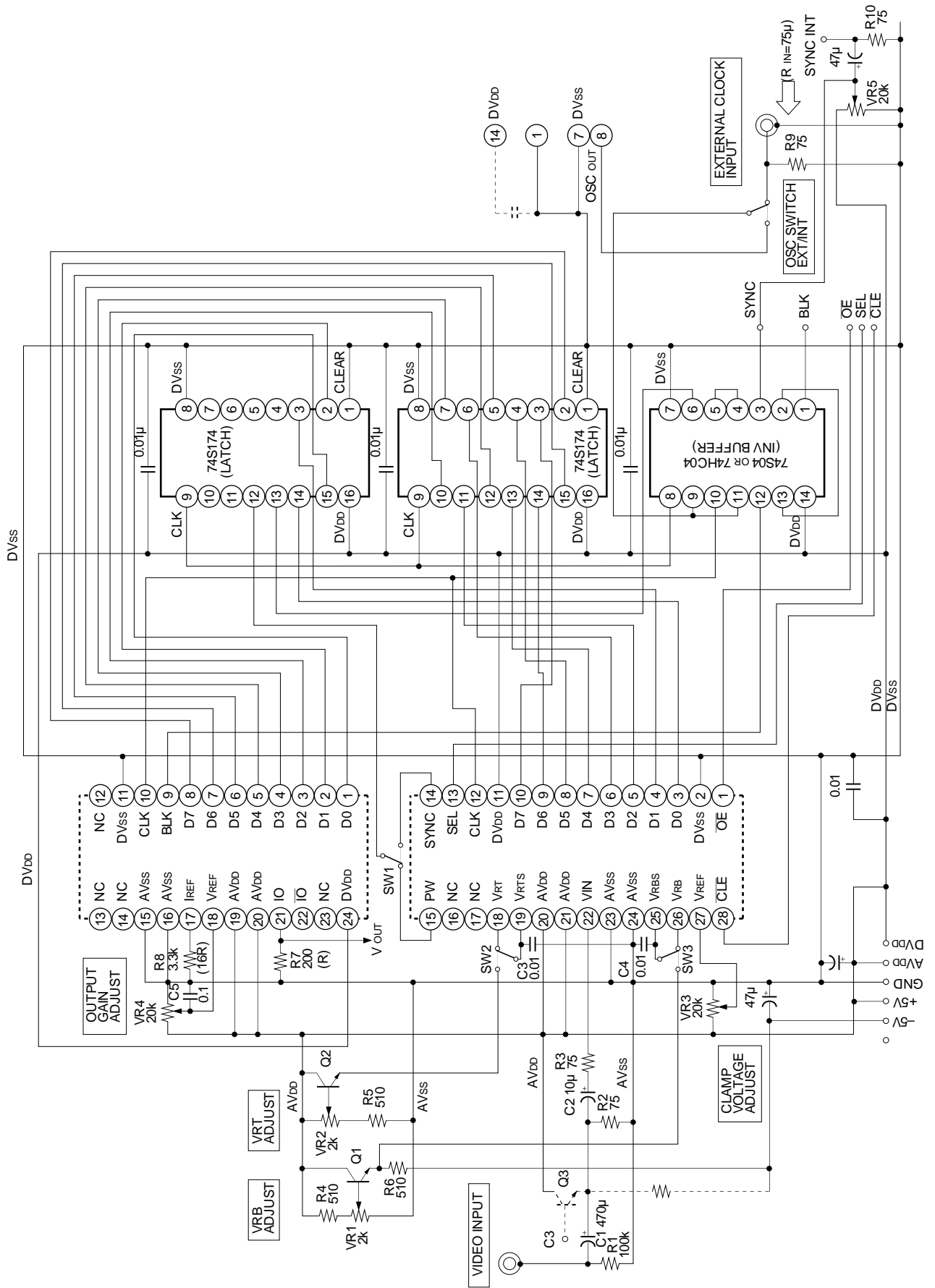

CMOS ADC/DAC Peripheral Circuit Board (Sub Board)

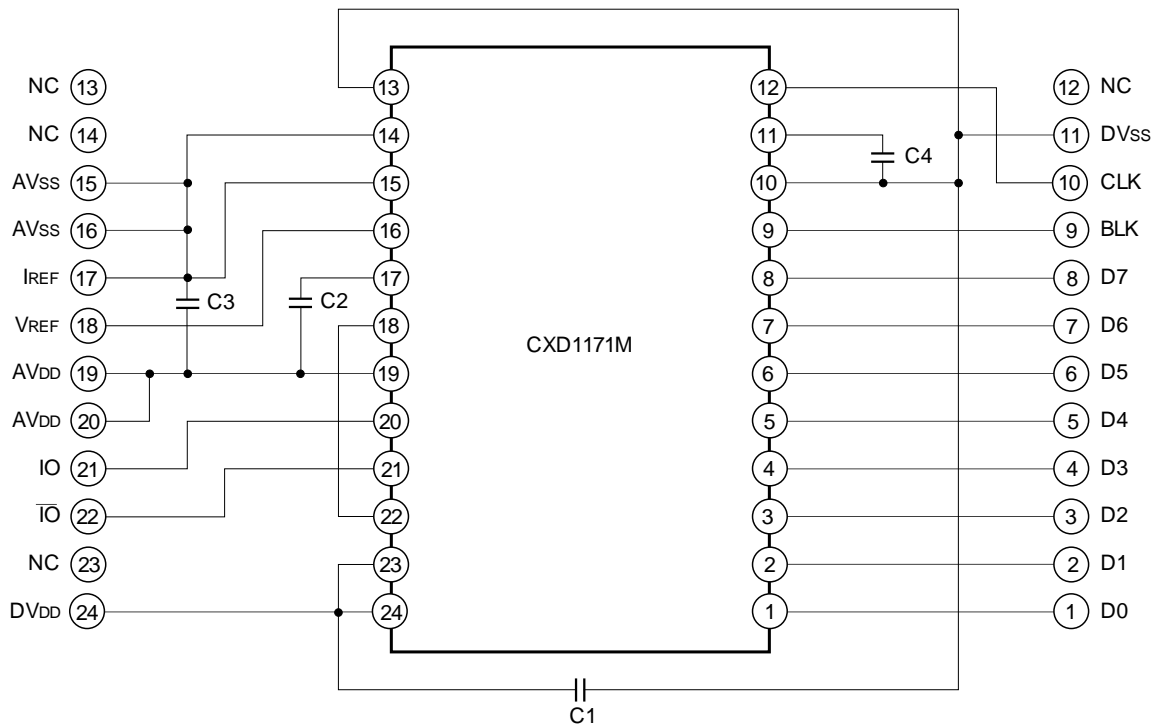
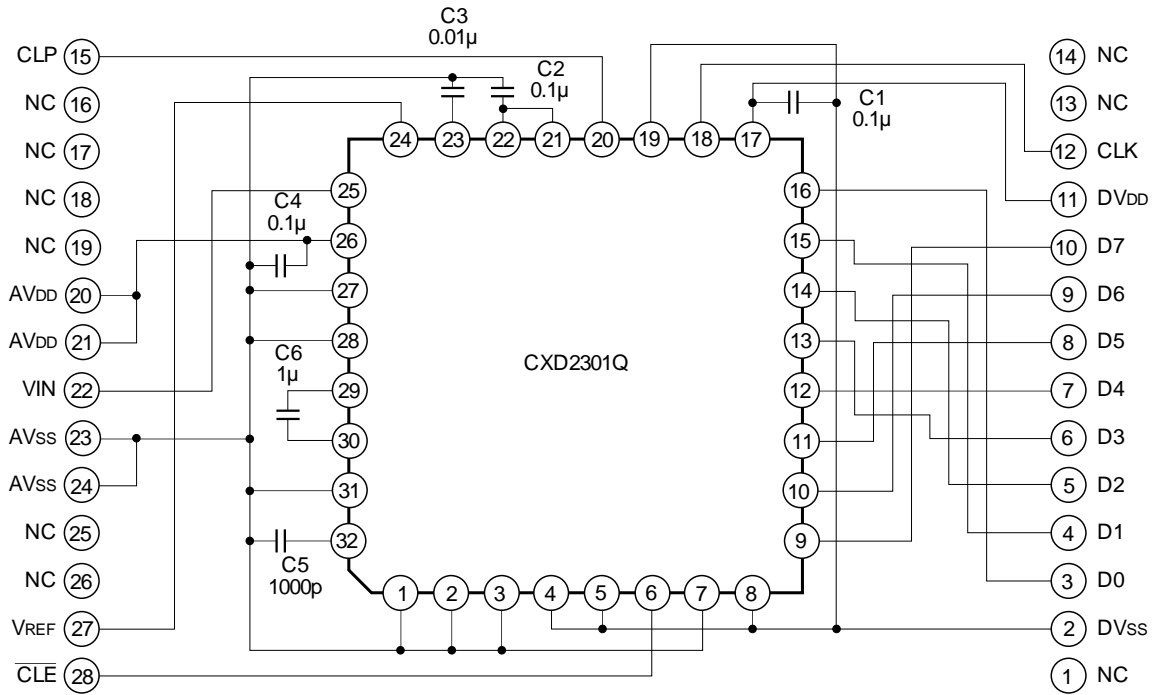

List of Parts**resistance**

R1	100k
R2	75Ω
R3	75Ω
R4	510Ω
R5	510Ω
R6	510Ω
R7	R = 200
R8	18R ≈ 3.3k
R9	75Ω
R10	75Ω
VR1	2k
VR2	2k
VR3	20k
VR4	20k
VR5	20k

transistor

Q1	2SC2785
Q2	2SC2785
Q3	2SC2785

ic

IC1	74S174
IC2	74S174
IC3	74S04

oscillator

OSC

others

connector	BNC071
SW	AT1D2M3

capacitance

C1	470μF/6.3V (chemical)
C2	10μF/16V (chemical)
C3	0.01μF
C4	0.01μF
C5	0.1μF
C6	0.1μF
C7	0.1μF
C8	0.1μF
C9	0.1μF
C10	0.1μF
C11	47μF/10V (chemical)
C12	47μF/10V (chemical)
C13	47μF/10V (chemical)
C14	0.1μF

Adjustment

1. Vref adjustment (VR1, VR2)

Adjustment of A/D converter reference voltage. V_{RB} is adjusted through VR1 and V_{RT} through VR2. When self bias is used, there is no need for adjustment. Reference voltage is set through self bias at delivery.

2. Setting of clamp reference voltage (VR3)

Clamp reference voltage is set.

3. DAC output full scale adjustment (VR4)

Full scale voltage of D/A converter output is adjusted at the PCB shipment, the full scale voltage is adjusted to approx. 2V.

4. Sync (clamp) pulse interface (VR5)

This adjustment enables interface with the signal generator and others at the PCB shipment, adjustment is performed to obtain a threshold of approx. 2.5V to an H sync of 0 to 5V.

5. \overline{OE} , SEL, Sync, BLK, \overline{CLE} , Sync INT

The following pins are set on the main board: Sync, \overline{CLE} , Sync INT (CXD2301Q) and BLK (CXD1171M), OE, SEL (not used). For the pins function, refer to the specifications. The difference between Sync pin and Sync INT pin is that you input a pulse above 3.5Vp-p to Sync INT pin. The pulse threshold is set through VR5. For input through Sync pin, pulse is input at TTL or CMOS level. In this case cut off the junction line between Sync pin and Sync INT pin.

At the PCB shipment the main board pins are set as follows.

- \overline{OE} Low
- SEL Low
- Sync Line junction with Sync INT pin
- \overline{CLE} Low (Clamp function ON)
- BLK Low (Blanking OFF)

6. Clamp pulse input method

The clamp pulse is directly input to CXD2301Q as show in Application Circuit examples (1) and (2). Use the direct input that is set at the PCB shipment.

Points on the PCB Pattern Layout

1. Set the layout not to have Digital current flow into Analog GND (Part 1). (For 1, see P.17 Component side diagram.)
2. At CXD2301Q sub board, C₂ and C₃ capacitors serve the important role of bringing out CXD2301Q's full performance.
These are over 0.1 μ F (ceramic) capacitors with good high frequency characteristics. Layout as close to the IC as possible.
3. Analog GND (AVss) and Digital GND (DVss) are on a common voltage and power source. Keeping ADC's DVss (Part 2) as close as possible to the voltage supply source will provide better results. That is, a layout where ADC is close to the voltage supply source, is recommended. (For 2, see P.17 Component side diagram.)
4. ADC samples analog signals at the clock falling edge point. Accordingly clocks supplied to ADC should not have any jitter.
5. The PCB layout shows ADC and DAC's Analog GND independently from the voltage supply source. The layout aims at providing an independent evaluation of ADC and DAC, as much as possible. On the actual board, common use will not cause any problems.

Notes on Operation

1. Reference voltage

By shorting V_{RT} and V_{RTS} , V_{RB} and V_{RBS} , CXD2301 has the self bias function that generates V_{RT} = about 2.6V and V_{RB} = about 0.5V. On the PCB, either self bias or the external reference voltage can be selected depending on the junction method of the jumper line. At shipment from the factory, reference voltage is provided in self bias. Also, to provide external reference voltage, adjust the dynamic range ($V_{RT} - V_{RB}$) to above 1.8Vp-p.

2. Clock input

There are 2 modes for the PCB clock input.

- 1) Provided from the external signal generator (External clock)
- 2) Using the crystal oscillator (built-in clock driver). (Internal clock)

The 2 modes are selected using the switch on the PCB.

3. The 2 Latch IC's (74S174) are not absolutely necessary for the evaluation of ADC and DAC. That is, operation will still be normal if ADC output data is directly input to DAC input. However, as ADC output data is hardly ever D/A converted without executing Digital signal processing, it was mounted to indicate an example layout of Digital signal processing IC. When the ADC output data is used, use the output of the latch IC.

4. When $\overline{\text{clamp}}$ is not used

Turning CLE to H will set OFF the clamp function. In this case, the DC element is cut off by means of C2 on the main board and DC voltage on the ADC side of C2 turns to about ($V_{RT} + V_{RB}$). To transfer DC elements of input signals, short C2. At that time, it is necessary to bias input signals, but keeping R2 open, Q3 can also be used as buffer. Use the open space for the bias circuit.

5. Clamp pulse latch

On the evaluation board, the clamp pulse is latched with ADC sampling CLK and then input to the CLP pin. This is to minimize V_{sag} due the synchronizing of noise and clamp pulse beat elements with GND sampling clock around ADC. If there are no problems with V_{sag} , latch is not necessary.

6. Peripheral through hole

There is a group of through holes on the Analog input, output and Logic. These are to be used when mounting additional circuits to the PCB. Use when necessary.

The connector hole on DAC part is used to mount the test chassis and the mount jack.

Silk Side

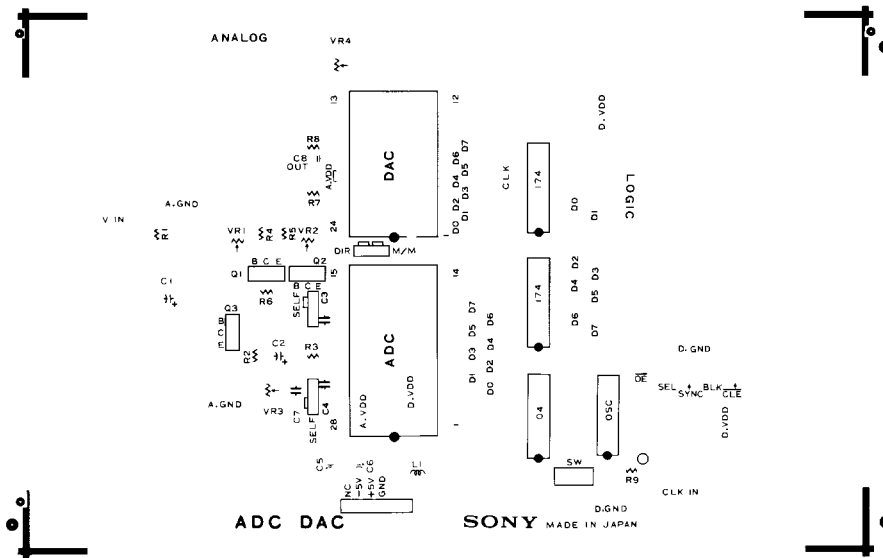

Component Side

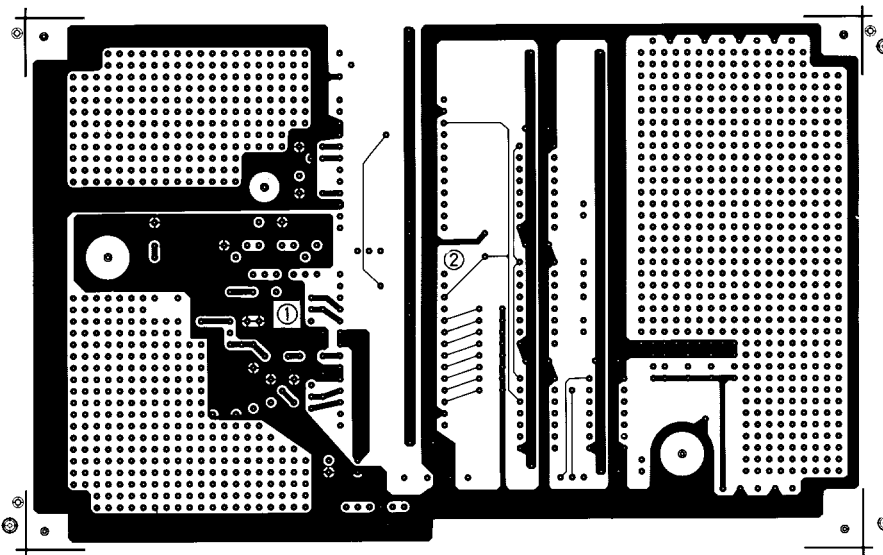

Soldering Side (Diagram seen from the component side)

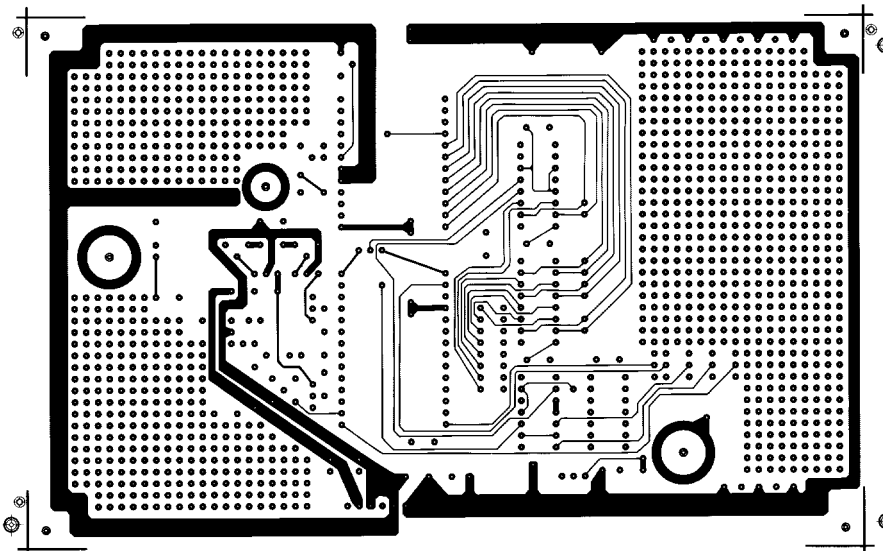

Package Outline

Unit: mm

32PIN QFP (PLASTIC)

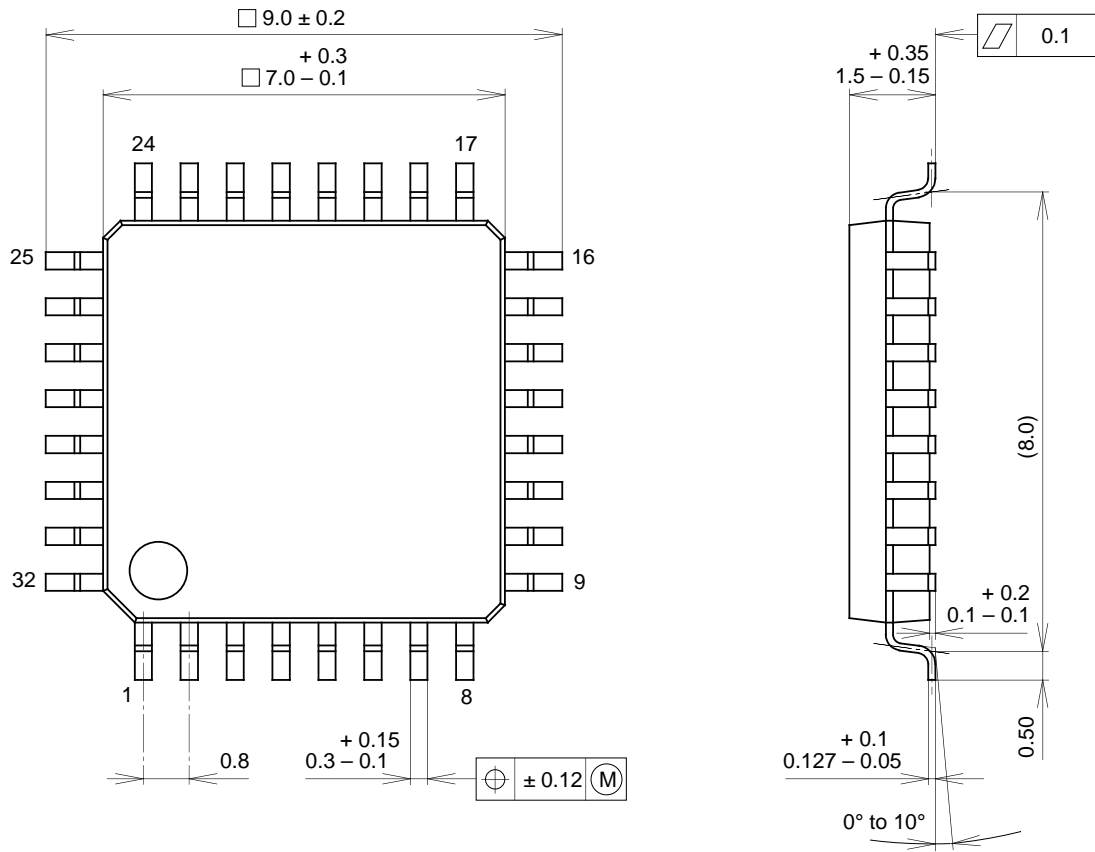

SONY CODE	QFP-32P-L01
EIAJ CODE	*QFP032-P-0707-A
JEDEC CODE	_____

PACKAGE MATERIAL	EPOXY RESIN
LEAD TREATMENT	SOLDER PLATING
LEAD MATERIAL	42 ALLOY
PACKAGE WEIGHT	0.2g



LittleDiode supplies new, hard to find or obsolete electronic components and semiconductors all over the world.

With over two million different components listed you are sure to find the part you need.

Feel free to visit us today at our online store:

LittleDiode.com

Looking forward to providing you with the best possible service.