

Digital Comb Filter (NTSC)

Description

The CXD2093Q is an adaptive intra-field three lines comb filter for NTSC systems, and can provide high-precision Y/C separation with a single chip.

Features

- Adaptive intra-field three lines comb filter
- For NTSC
- Vertical enhancer
- Horizontal aperture correction
- 8-bit A/D converter (1-channel)
- 8-bit D/A converter (2-channel)
- 4× PLL
- Sync tip clamp

Applications

Y/C separation for color TVs and VCRs

Structure

Silicon gate CMOS IC Structure

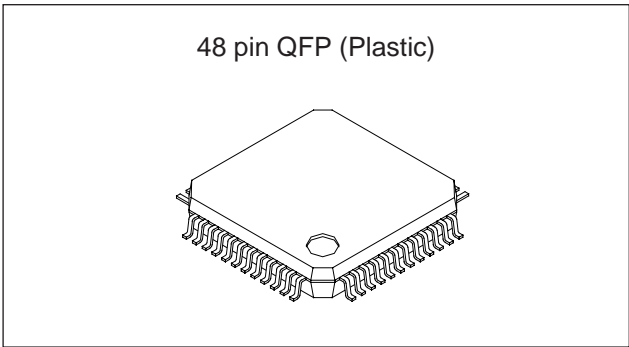

Absolute Maximum Ratings (Ta = 25°C, Vss = 0V)

• Supply voltage	DV _{DD}	V _{SS} – 0.5 to +7.0	V
	DAVD	V _{SS} – 0.5 to +7.0	V
	ADVD	V _{SS} – 0.5 to +7.0	V
	PLVD	V _{SS} – 0.5 to +7.0	V
	CLVD	V _{SS} – 0.5 to +7.0	V
• Input voltage	V _I	V _{SS} – 0.5 to V _{DD} + 0.5	V
• Output voltage	V _O	V _{SS} – 0.5 to V _{DD} + 0.5	V
• Storage temperature	T _{stg}	–55 to +150	°C

Recommended Operating Conditions

• Supply voltage	DV _{DD}	5.0 ± 0.25	V
	DAVD	5.0 ± 0.25	V
	ADVD	5.0 ± 0.25	V
	PLVD	5.0 ± 0.25	V
	CLVD	5.0 ± 0.25	V
• Analog input	ADIN	1.75	V _{p-p}
• Operating temperature	T _{opr}	–20 to +70	°C

Sony reserves the right to change products and specifications without prior notice. This information does not convey any license by any implication or otherwise under any patents or other right. Application circuits shown, if any, are typical examples illustrating the operation of the devices. Sony cannot assume responsibility for any problems arising out of the use of these circuits.

Pin Configuration

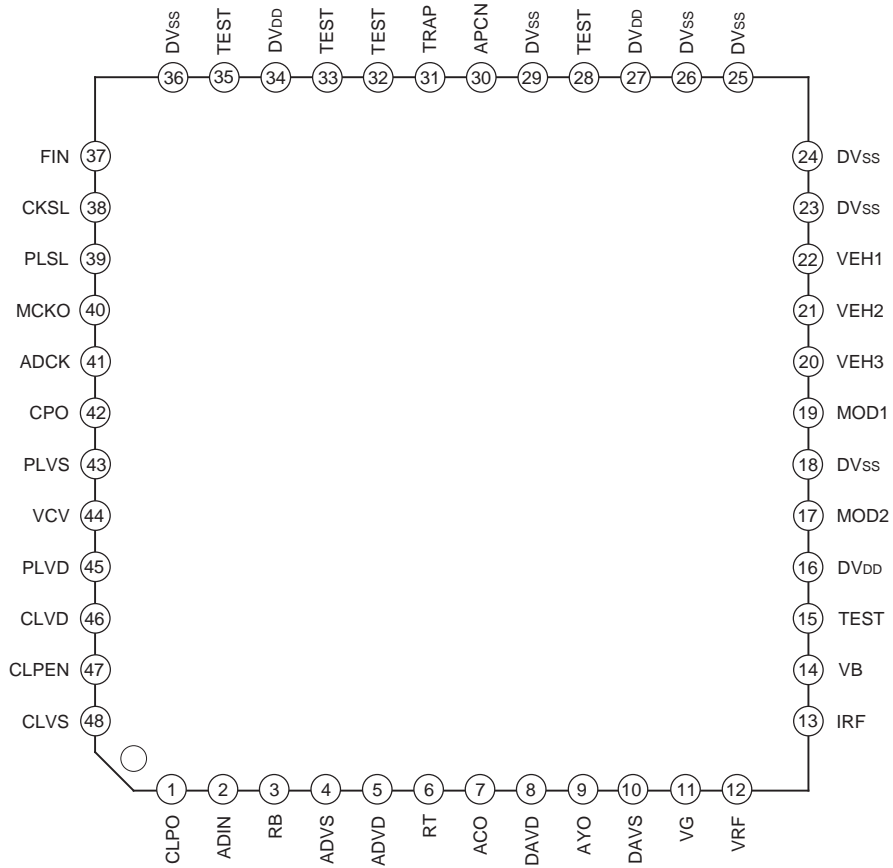

Block Diagram

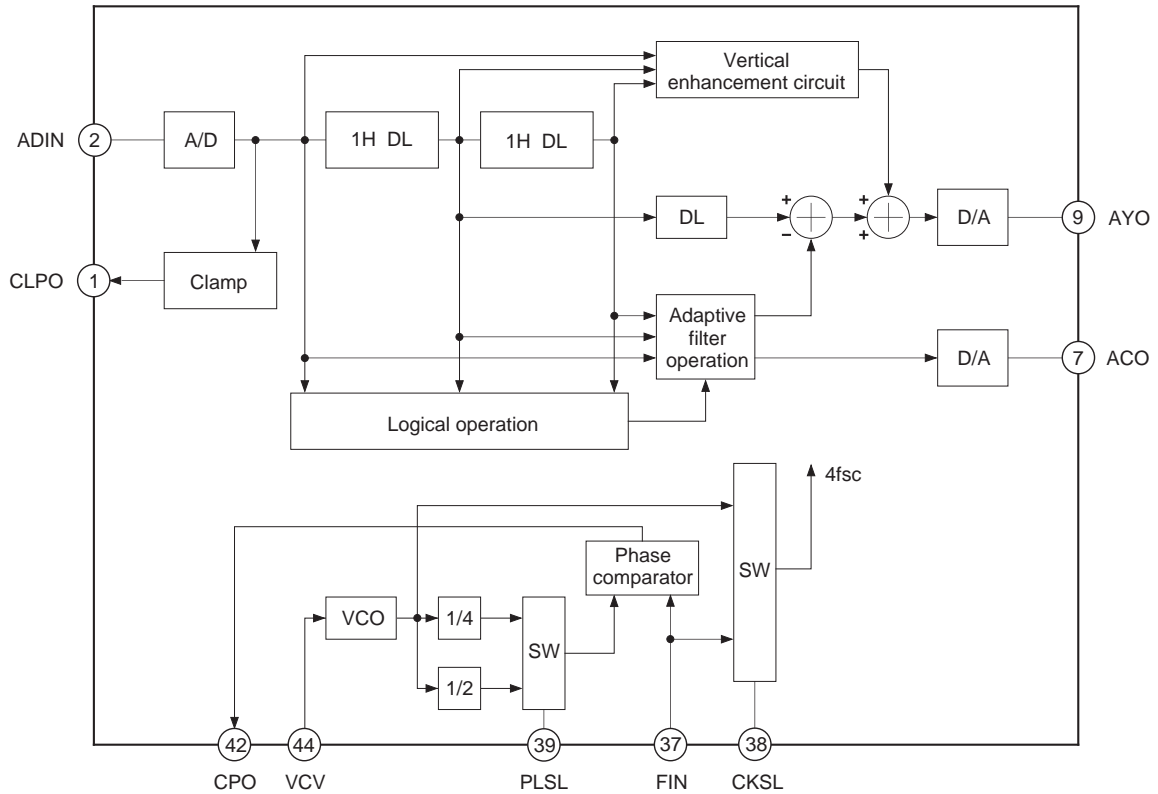

Pin Description

Pin No.	Symbol	I/O	Description													
1	CLPO	O	Internal clamp circuit current output. Connect to ADIN when using the internal clamp. Leave this pin open when not in use.													
2	ADIN	I	Comb filter analog input (A/D converter input).													
3	RB	O	Reference bottom voltage for the A/D converter (0.52V typ.).													
4	ADVS	—	A/D converter analog ground.													
5	ADVD	—	A/D converter analog power supply. (5.0V)													
6	RT	O	Reference top voltage for the A/D converter (2.60V typ.).													
7	ACO	O	Analog chroma signal output. Output can be obtained by connecting a resistor between this pin and the analog ground.													
8	DAVD	—	D/A converter analog power supply. (5.0V)													
9	AYO	O	Analog luminance signal output. Output can be obtained by connecting a resistor between this pin and the analog ground.													
10	DAVS	—	D/A converter analog ground.													
11	VG	O	D/A converter related pin. Connect a capacitor of approximately 0.1 μ F between this pin and the analog power supply (DAVD).													
12	VRF	I	Sets the full-scale value of the Y and C-channel D/A converter output signal.													
13	IRF	O	Connect a resistor of "16R" (16 times the output resistor "R" of the D/A converter).													
14	VB	O	D/A converter related pin. Connect to the analog ground (DAVS) via a capacitor of approximately 0.1 μ F.													
15	TEST	I	Test pin. Normally fix to "Low".													
16	DV _{DD}	—	Digital power supply. (5.0V)													
18	DV _{SS}	—	Digital ground.													
17	MOD2	I	Y/C separation mode setting.													
19	MOD1	I		<table border="0"> <tr> <td>MOD2</td> <td>MOD1</td> <td></td> </tr> <tr> <td>L</td> <td>L</td> <td>Adaptive processing mode</td> </tr> <tr> <td>H</td> <td>L</td> <td>BPF separation mode</td> </tr> <tr> <td>H</td> <td>H</td> <td>Through mode</td> </tr> </table>	MOD2	MOD1		L	L	Adaptive processing mode	H	L	BPF separation mode	H	H	Through mode
MOD2	MOD1															
L	L	Adaptive processing mode														
H	L	BPF separation mode														
H	H	Through mode														
20	VEH3	I														
21	VEH2	I	Vertical enhancement setting. Can be set in 8 stages from VEH3 VEH2 VEH1: LLL (off) to HHH (max.)													
22	VEH1	I														
23	DV _{SS}	—	Digital ground.													
24	DV _{SS}	—	Digital ground.													
25	DV _{SS}	—	Digital ground.													
26	DV _{SS}	—	Digital ground.													
27	DV _{DD}	—	Digital power supply. (5.0V)													

Pin No.	Symbol	I/O	Description
28	TEST	I	Test pin. Normally fix to "Low".
29	DVss	—	Digital ground.
30	APCN	I	Horizontal aperture correction circuit setting. Low: Off, High: On.
31	TRAP	I	Trap filter setting. Low: Off, High: On.
32	TEST	I	Test pin. Normally open or fix to "Low".
33	TEST	I	Test pin. Normally open or fix to "Low".
34	DVDD	—	Digital power supply. (5.0V)
35	TEST	I	Test pin. Normally open or fix to "Low".
36	DVss	—	Digital ground.
37	FIN	I	Clock input. Input the burst-locked fsc (2fsc) when using the internal PLL. Input the burst-locked 4fsc when not using the internal PLL.
38	CKSL	I	PLL control. Low: The internal PLL is not used. The clock (4fsc) which is input to FIN is supplied internally. High: The internal PLL is used. VCO oscillation output 4fsc clock is supplied internally.
39	PLSL	I	Selects the clock input to FIN. Low: fsc, High: 2fsc. When inputting 4fsc to FIN (when not using the internal PLL), this pin may be set to either "Low" or "High".
40	MCKO	O	Clock (4fsc) output.
41	ADCK	I	Clock input for A/D converter. Normally connect to MCKO.
42	CPO	O	PLL phase comparator output. Leave open when not using the PLL.
43	PLVS	—	PLL analog ground.
44	VCV	I	VCO control voltage input. Connect to PLVS when not using the PLL.
45	PLVD	—	PLL analog power supply. (5.0V)
46	CLVD	—	Clamp D/A converter analog power supply. (5.0V)
47	CLPEN	I	Clamp circuit enable pin. Low: Clamp on, High: Clamp off.
48	CLVS	—	Clamp D/A converter analog ground.

Electrical Characteristics

DC Characteristics

(V_{DD} = 4.75 to 5.25V, V_{SS} = 0V, T_a = -20 to +70°C)

Item	Symbol	Measurement conditions	Min.	Typ.	Max.	Unit	Applicable pins
Supply voltage	DV _{DD}	—	4.75	5.0	5.25	V	*1
	DAVD						
	ADVD						
	PLVD						
	CLVD						
Operating temperature	Topr	—	-20		+70	°C	
Supply current	I _{DD}	Clock 14.3MHz	—	85	120	mA	—
Input/output voltage	V _I , V _O	—	V _{SS}		V _{DD}	V	*2
Input voltage	V _{IH}	CMOS level input	0.7V _{DD}			V	*3
	V _{IL}				0.3V _{DD}		
Input rise/fall time	t _r , t _f	—	0		500	ns	*1
Output voltage	V _{OH}	I _{OH} = -2mA	V _{DD} - 0.8			V	*4
		I _{OH} = -3mA					*5
	V _{OL}	I _{OL} = 4mA			0.4		*4
		I _{OL} = 1.5mA					*5
Clock input amplitude	V _{IN}	f _{max} = 50MHz sine wave	0.5			V _{p-p}	*6
Feedback resistance value	R _{FB}	V _{IN} = V _{SS} or V _{DD}	250k	1M	2.5M	Ω	
Input leak current	I _{IL} , I _{IH}	V _{IN} = V _{SS} or V _{DD}	-10		10	μA	*7
	I _{IH}	V _{IH} = V _{DD}	40	100	240		*8
Clock amplifier output delay	—	—	3.0	9.0	18.0	ns	*9

*1 All pins

*2 All pins other than *6

*3 All input pins other than *6

*4 All output pins other than *5

*5 CPO (Pin 42)

*6 FIN (Pin 37)

*7 All input pins other than *8

*8 Pins 32, 33 and 35

*9 MCKO (Pin 40)

I/O Pin Capacitance

(Ta = 25°C, f = 1MHz, VIN = VOUT = 0V)

Item	Symbol	Min.	Min.	Max.	Unit
Input pin capacitance	CIN	—	—	9	pF
Output pin capacitance	COUT	—	—	11	

Internal 8-bit A/D Converter Characteristics

(VDD = 5V, Ta = 25°C, f = 10MHz)

Item	Symbol	Conditions	Min.	Typ.	Max.	Unit
Resolution	n		—	8	—	bit
Max. conversion speed	fmax		14.3	—	—	MSPS
Analog input bandwidth	BW	-3dB	—	18	—	MHz
Self bias	VRB		0.48	0.52	0.56	V
	VRT - VRB		1.96	2.08	2.22	V
Output data delay	tpd		—	—	45	ns
Differential linearity error	ED		-1.0	—	+1.0	LSB
Integral linearity error	EL		-2.0	—	+2.0	LSB

Internal 8-bit D/A Converter Characteristics

(VDD = 5V, VRF = 2V, RIRF = 3.3kΩ, R = 200Ω, Ta = 25°C, f = 10MHz)

Item	Symbol	Conditions	Min.	Typ.	Max.	Unit
Resolution	n		—	8	—	bit
Max. conversion speed	fmax		14.3	—	—	MSPS
Differential linearity error	ED		-0.8	—	+0.8	LSB
Integral linearity error	EL		-2.0	—	+2.0	LSB
Output full-scale voltage	VFS		1.805	1.90	1.995	V
Output full-scale current	IFS		—	9.5	15	mA
Output offset voltage	Vos		—	—	1.0	mV
Glitch energy	GE	R = 75Ω, 1Vp-p output	—	30	—	pV-s

Internal Clamp

(VDD = 5V, Ta = 25°C, f = 10MHz)

Item	Symbol	Conditions	Min.	Typ.	Max.	Unit
Clamp level *1	CLV		—	0.67	—	V

*1 Sync tip clamp

Description of Functions

- Y/C separation mode

The Y/C separation mode can be switched by the following pin settings.

Mode name	MOD2 (Pin 17)	MOD1 (Pin 19)
Adaptive processing mode	L	L
BPF separation mode	H	L
Through mode	H	H

Adaptive processing mode:

Y/C separation is performed by detecting the correlation between three lines and switching between comb filter and BPF processing.

BPF separation mode:

Y/C separation is performed only by BPF processing.

Through mode:

The composite video signal input from ADIN (Pin 2) is A/D converted and then D/A converted without modification. D/A outputs are AYO (Pin 9) and ACO (Pin 7).

- Horizontal aperture correction circuit

This circuit corrects the frequency response degradation caused by the aperture effects accompanying D/A conversion. This circuit is valid in the adaptive processing and BPF separation modes noted above.

- Trap filter circuit

A trap filter is applied to remove the frequency components near fsc in the luminance signal after Y/C separation.

This reduces the fsc frequency component gain by approximately 2.5dB.

This circuit is valid in the adaptive processing and BPF separation modes noted above.

- Using the internal PLL (clock selection method)

	FIN (Pin 37)	CKSL (Pin 38)	PLSL (Pin 39)
PLL used	fsc input	H	L
	2fsc input	H	H
PLL not used	4fsc input	L	L/H

• Vertical enhancement circuit

This circuit generates an enhanced component in accordance with the vertical aperture component (luminance difference from the preceding and following lines) of the luminance signal. The vertical aperture of the picture can be enhanced naturally by adding this enhanced component to the luminance signal after Y/C separation.

The enhancement level can be set in eight steps. The size of $|a|$ in the figure below varies according to the pin settings. Accordingly, enhanced level can be changed for portions of natural pictures with small luminance differences where the effects are particularly easy to see.

Portions with large luminance differences are cut with a limiter so that they are not excessively enhanced. Also, portions with extremely large luminance differences such as white and black lines are not enhanced because they need be enhanced any more.

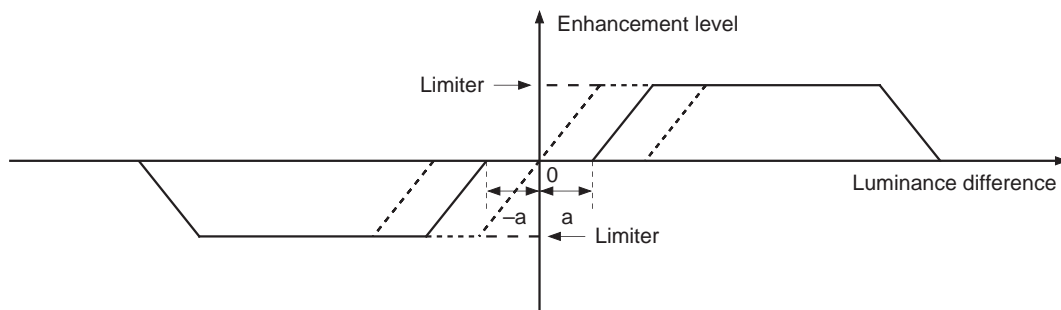

Enhancement level	Pin settings			$ a $
	VEH3 (Pin 20)	VEH2 (Pin 21)	VEH1 (Pin 22)	
OFF	L	L	L	—
1	L	L	H	Large ↑
2	L	H	L	
3	L	H	H	
4	H	L	L	↓ Small
5	H	L	H	
6	H	H	L	
Max	H	H	H	

Application Circuit for D/A Converter Block

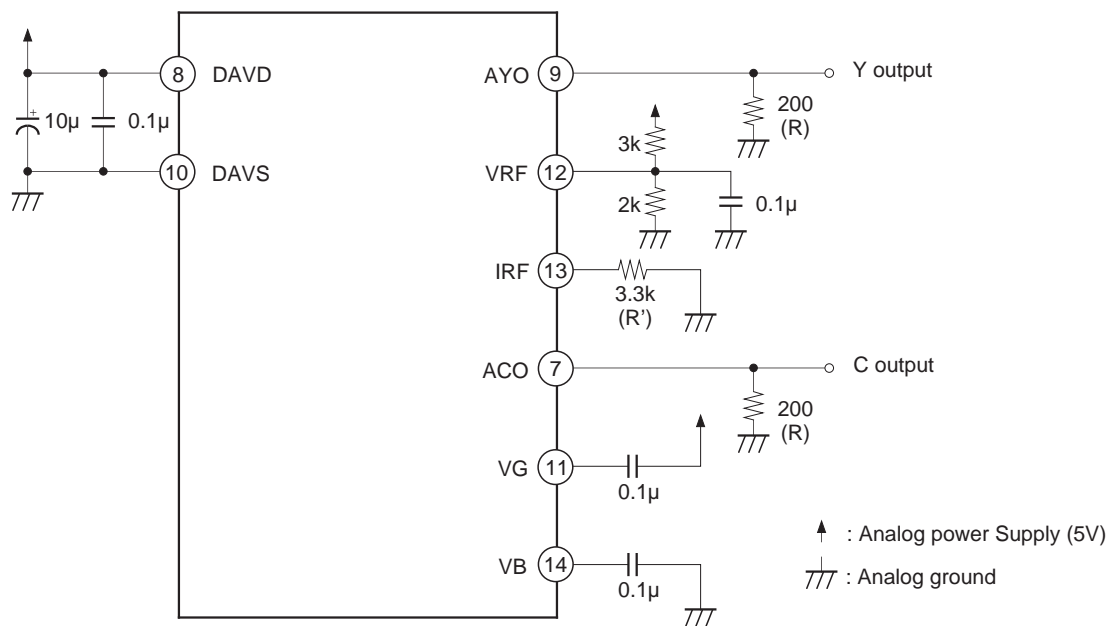

• Method of selecting the output resistor

The CXD2093Q has a built-in current output type D/A converter. To obtain the output voltages, connect resistors to the AYO and ACO pins.

The specs are as follows: output full-scale voltage $V_{FS} = 0.5$ to 2.0 [V], output full-scale current $I_{FS} = 0$ to 15 [mA].

Calculate the output resistance value using the relationship $V_{FS} = I_{FS} \times R$. In addition, connect a resistor of 16 times the output resistor to the reference current pin (IRF). In case this results in a unpractical value, use a resistance value as close to the calculated value as possible.

Note that, at this time, $V_{FS} = V_{RF} \times 16R/R'$ (V_{RF} : Pin voltage of VRF). Here, R is the resistor connected to AYO/ACO, and R' is the resistor connected to IRF.

Power consumption can be reduced by using higher resistance values, but the glitch energy and data settling time increase contrastingly. Set the optimum values according to the system applications.

• V_{DD} , V_{SS}

Separate the analog and digital systems around the device to reduce the effects of noise. DAVD is bypassed to DAVS as close to each other as possible through a ceramic capacitor of approximately $0.1\mu\text{F}$.

Application circuits shown are typical examples illustrating the operation of the devices. Sony cannot assume responsibility for any problems arising out of the use of these circuits or for any infringement of third party patent and other right due to same.

External Connection Diagram

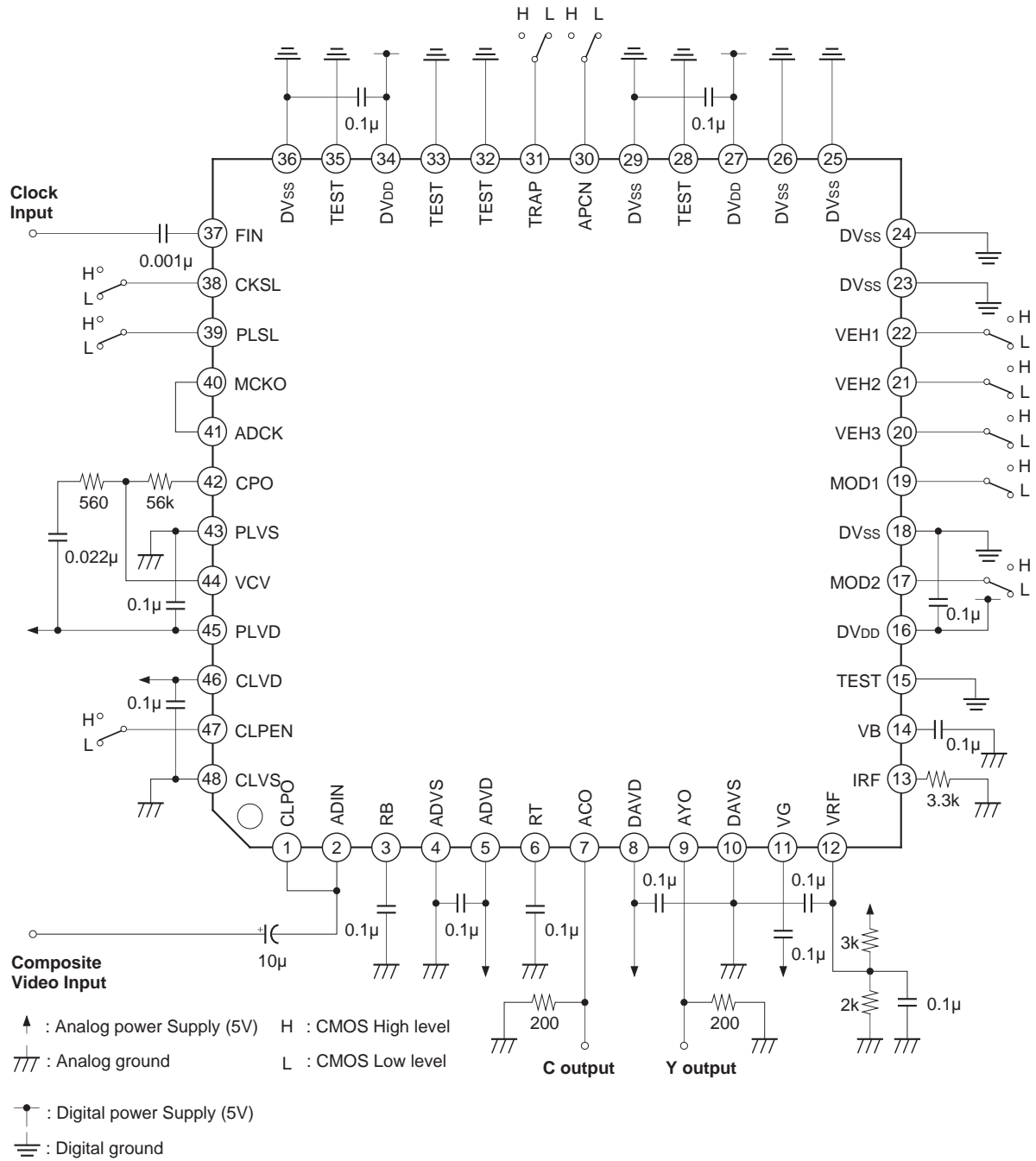

Application circuits shown are typical examples illustrating the operation of the devices. Sony cannot assume responsibility for any problems arising out of the use of these circuits or for any infringement of third party patent and other right due to same.

Notes on Operation

- Make the wiring for the signal input to ADIN (Pin 2) as short as possible. Also, drive the input signal to ADIN at low impedance.
- Make the analog and digital power supply and GND lines as wide and short as possible to ensure low impedance.
- Bypass the analog and digital power supply pins to GND with a ceramic capacitor of about 0.1 μ F connected as close to the pin as possible.
- Input a clock that is locked to the burst signal of the input video signal.
- Separate the wiring to the clock input pin FIN (Pin 37) from the external analog circuits, analog power supplies and analog GND.

- ADIN (analog input signal)

Set the input signal peak-to-peak value V_{PP} to 1.75V or less. Additionally, V_{PP} is recommended to be 1.3V or more since the A/D converter input dynamic range should be made as large as possible.

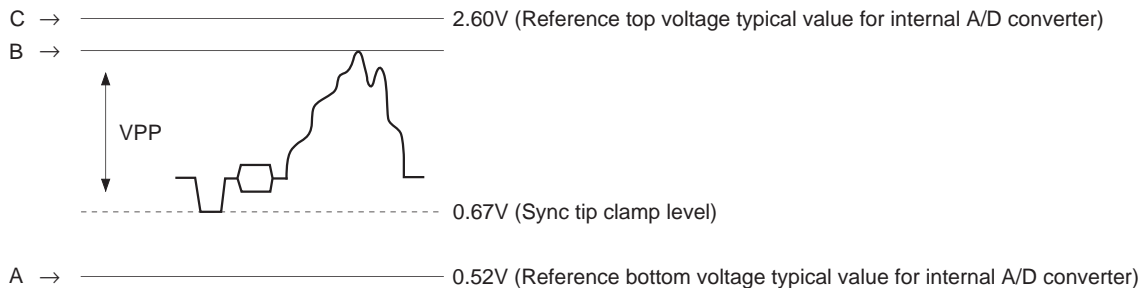

The DC level at the ADIN pin is as shown in the diagram above when the internal sync tip clamp is used.

Labeling the internal D/A converter AYO output full-scale voltage as V_{FS} , the correspondence between the ADIN pin voltage and AYO output pin voltage (DC level) is as follows;

DC voltage at point B → AYO maximum output voltage [V]

DC voltage at point A → 0 [V]

DC voltage at point C → V_{FS} [V]

The V_{FS} is the AYO output voltage generated when the voltage equivalent to the point C is input.

- Internal delay

The delay from the internal A/D converter to the D/A converter output is as follows;

$1H + 24.5 \text{ clocks} + \alpha \text{ns}$

(α : D/A converter analog output delay = approximately 20ns)

The 24.5 clocks are the sum of the clocks shown below;

A/D converter: 3.5 clocks ("0.5" is for fetching the data at the fall of the clock.)

Internal logic: 20 clocks

D/A converter: 1 clock

Package Outline

Unit : mm

48PIN QFP (PLASTIC)

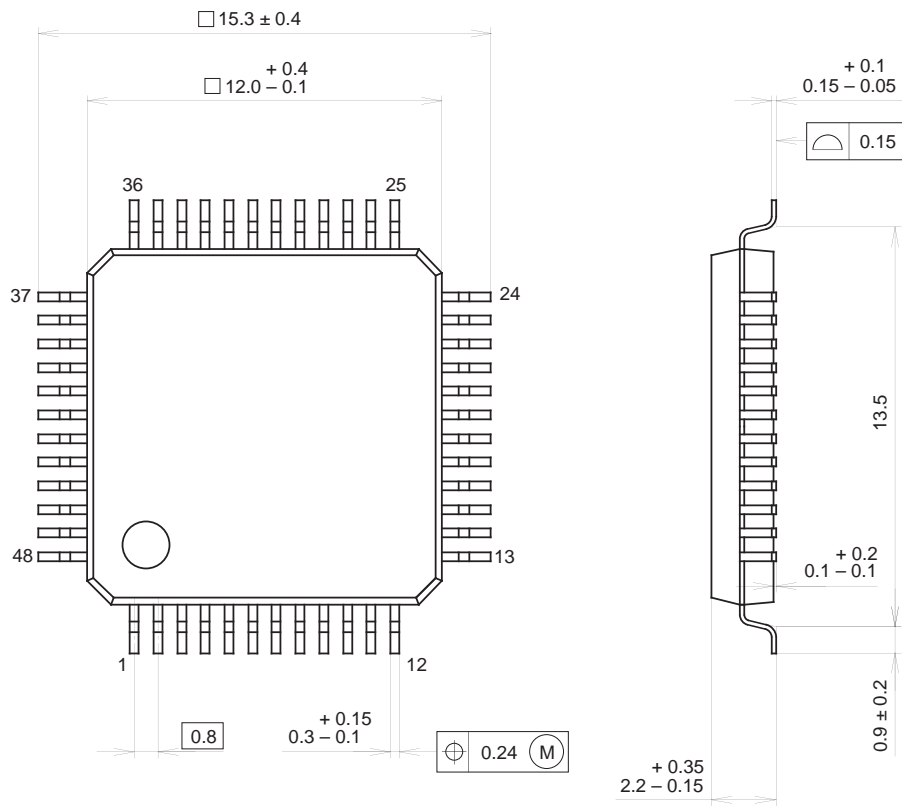

PACKAGE STRUCTURE

SONY CODE	QFP-48P-L04
EIAJ CODE	QFP048-P-1212
JEDEC CODE	_____

PACKAGE MATERIAL	EPOXY RESIN
LEAD TREATMENT	SOLDER / PALLADIUM PLATING
LEAD MATERIAL	42/COPPER ALLOY
PACKAGE MASS	0.7g



LittleDiode supplies new, hard to find or obsolete electronic components and semiconductors all over the world.

With over two million different components listed you are sure to find the part you need.

Feel free to visit us today at our online store:

LittleDiode.com

Looking forward to providing you with the best possible service.