

CD-ROM DECODER

Description

CXD1803AQ/AR is a CD-ROM decoder LSI with a built-in ADPCM decoder.

Features

- Compatible with CD-ROM, CD-I and CD-ROM XA formats
- Real time error correction
- Capable of handling up to quadruple speed playback
- Connectable with standard SRAM of up to 2M-bit (256K-byte)
- Connectable with standard DRAM of up to 2M-bit (256K-byte)
(2 DRAM's of 256K × 4)
- All audio output sampling frequencies: 132.3 KHz (built-in oversampling filter)
- De-emphasis digital filter
- Digital attenuator
- Connectable directly with Sony's SCSI controller CXD1185CQ.

Applications

CD-ROM drives

Structure

Silicon gate CMOS IC

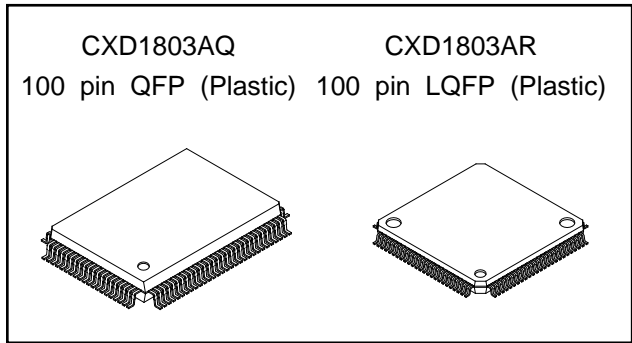

Absolute Maximum Ratings (Ta=25°C)

- | | | | |
|-------------------------|------|------------------|----|
| • Supply voltage | VDD | -0.5 to +7.0 | V |
| • Input voltage | VI | -0.5 to VDD +0.5 | V |
| • Output voltage | VO | -0.5 to VDD +0.5 | V |
| • Operating temperature | Topr | -20 to +75 | °C |
| • Storage temperature | Tstg | -55 to +150 | °C |

Recommended Operating Conditions

- | | | | |
|-------------------------|------|--------------------------|----|
| • Supply voltage | VDD | +3.5 to +5.5 (+5.0 typ.) | V |
| • Operating temperature | Topr | -20 to +75 | °C |

Sony reserves the right to change products and specifications without prior notice. This information does not convey any license by any implication or otherwise under any patents or other right. Application circuits shown, if any, are typical examples illustrating the operation of the devices. Sony cannot assume responsibility for any problems arising out of the use of these circuits.

Block Diagram

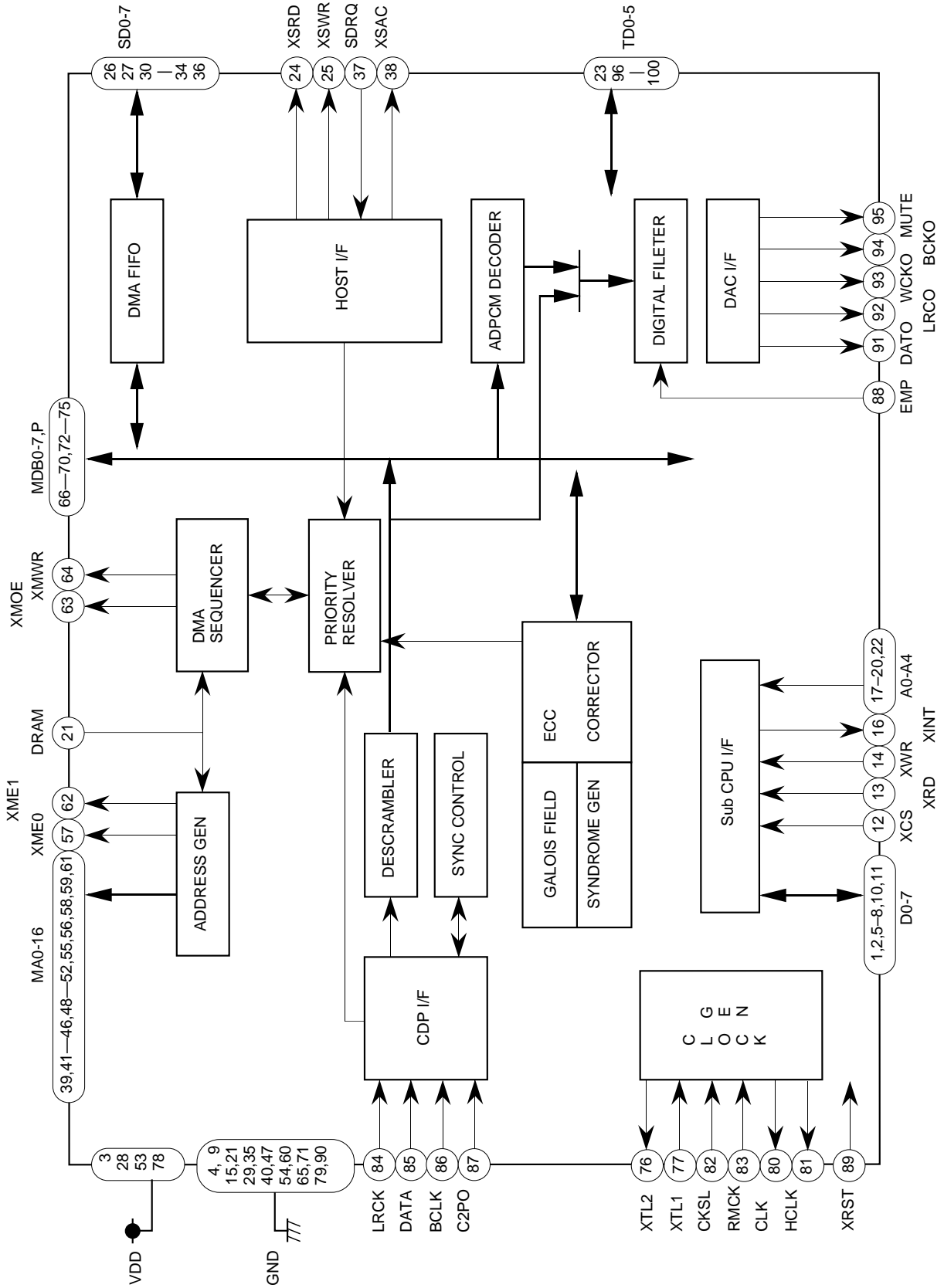

The pin numbers in the diagram are for the CXD1803AQ.

Pin Description

Pin No.		Symbol	I/O	Description
Q	R			
1	99	D0	I/O	Sub CPU data bus
2	100	D1	I/O	Sub CPU data bus
3	1	VDD	—	Power supply (+5 V)
4	2	GND	—	Ground
5	3	D2	I/O	Sub CPU data bus
6	4	D3	I/O	Sub CPU data bus
7	5	D4	I/O	Sub CPU data bus
8	6	D5	I/O	Sub CPU data bus
9	7	GND	—	Ground
10	8	D6	I/O	Sub CPU data bus
11	9	D7	I/O	Sub CPU data bus
12	10	XCS	I	IC select negative logic signal from sub CPU
13	11	XRD	I	Strobe negative logic signal to read this IC internal register from sub CPU
14	12	XWR	I	Strobe negative logic signal to write this IC internal register from sub CPU
15	13	GND	—	Ground
16	14	XINT	O	Interrupt request negative logic signal from IC to sub CPU
17	15	A0	I	Sub CPU address
18	16	A1	I	Sub CPU address
19	17	A2	I	Sub CPU address
20	18	A3	I	Sub CPU address
21	19	DRAM	I	Memory type selection signal. High: DRAM, Low: SRAM
22	20	A4	I	Sub CPU address
23	21	TD0	I/O	Test input/output
24	22	XSRD	O	Strobe negative logic signal to read SCSI controller internal register
25	23	XSWR	O	Strobe negative logic signal to write SCSI controller internal register
26	24	SD0	I/O	SCSI controller data bus
27	25	SD1	I/O	SCSI controller data bus
28	26	VDD	—	Power supply (+5 V)
29	27	GND	—	Ground
30	28	SD2	I/O	SCSI controller data bus
31	29	SD3	I/O	SCSI controller data bus
32	30	SD4	I/O	SCSI controller data bus
33	31	SD5	I/O	SCSI controller data bus
34	32	SD6	I/O	SCSI controller data bus

Pin No.		Symbol	I/O	Description
Q	R			
35	33	GND	—	Ground
36	34	SD7	I/O	SCSI controller data bus
37	35	SDRQ	I	SCSI data request positive logic signal
38	36	XSAC	O	SCSI acknowledge negative logic signal
39	37	MA0	O	Buffer memory address (LSB)
40	38	GND	—	Ground
41	39	MA1	O	Buffer memory address
42	40	MA2	O	Buffer memory address
43	41	MA3	O	Buffer memory address
44	42	MA4	O	Buffer memory address
45	43	MA5	O	Buffer memory address
46	44	MA6	O	Buffer memory address
47	45	GND	—	Ground
48	46	MA7	O	Buffer memory address
49	47	MA8	O	Buffer memory address
50	48	MA9	O	Buffer memory address
51	49	MA10	O	Buffer memory address
52	50	MA11	O	Buffer memory address
53	51	VDD	—	Power supply (+5 V)
54	52	GND	—	Ground
55	53	MA12	O	Buffer memory address
56	54	MA13	O	Buffer memory address
57	55	XME0	O	Memory chip enable negative logic signal
58	56	MA14	O	Buffer memory address
59	57	MA15	O	Buffer memory address
60	58	GND	—	Ground
61	59	MA16 XRAS	O	Buffer memory address DRAM RAS signal
62	60	XME1	O	Memory chip enable negative logic signal
63	61	XMOE XCAS	O	Buffer memory output enable negative logic signal DRAM CAS signal
64	62	XMWR	O	Buffer memory write enable negative logic signal
65	63	GND	—	Ground
66	64	MDB0	I/O	Buffer memory data bus
67	65	MDB1	I/O	Buffer memory data bus

Pin No.		Symbol	I/O	Description
Q	R			
68	66	MDB2	I/O	Buffer memory data bus
69	67	MDB3	I/O	Buffer memory data bus
70	68	MDB4	I/O	Buffer memory data bus
71	69	GND	—	Ground
72	70	MDB5	I/O	Buffer memory data bus
73	71	MDB6	I/O	Buffer memory data bus
74	72	MDB7	I/O	Buffer memory data bus
75	73	MDBP	I/O	Buffer memory data bus (for error flag)
76	74	XTL2	O	Crystal oscillation circuit output
77	75	XTL1	I	Crystal oscillation circuit input (16.9344 MHz)
78	76	VDD	—	Power supply (+5 V)
79	77	GND	—	Ground
80	78	CLK	O	16.9344 MHz clock output
81	79	HCLK	O	8.4672 MHz clock output
82	80	CKSL	I	Clock select signal for CD-ROM decoder
83	81	RMCK	I	Clock signal for CD-ROM decoder
84	82	LRCK	I	LR clock signal from CD DSP (for discriminating L, R channels)
85	83	DATA	I	Data signal from CD DSP
86	84	BCLK	I	DATA pin strobe clock signal (bit clock)
87	85	C2PO	I	Error flag (C2 pointer) positive logic signal from CD DSP
88	86	EMP	I	Emphasis on positive logic signal from CD DSP
89	87	XRST	I	Reset negative logic signal
90	88	GND	—	Ground
91	89	DATO	O	Data signal to DAC (D/A converter)
92	90	LRCO	O	LR clock signal to DAC
93	91	WCKO	O	Word lock signal to DAC
94	92	BCKO	O	Bit clock signal to DAC
95	93	MUTE	O	Mute positive logic signal
96	94	TD5	I/O	Test input/output
97	95	TD4	I/O	Test input/output
98	96	TD3	I/O	Test input/output
99	97	TD2	I/O	Test input/output
100	98	TD1	I/O	Test input/output

Note: The pin numbers in the column "Q" are for the CXD1803AQ, and those in the column "R" are for the CXD1803AR.

Electrical Characteristics

DC Characteristics

(V_{DD} = 5 V ± 10%, V_{SS} = 0 V, T_{opr} = -20 - 75°C)

Item	Symbol	Conditions	Min.	Typ.	Max.	Unit
TTL input level pin *1 High level input voltage	V _{IH1}		2.2			V
TTL input level pin *1 Low level input voltage	V _{IL1}				0.8	V
CMOS input level pin *2 High level input voltage	V _{IH2}		0.7V _{DD}			V
CMOS input level pin *2 Low level input voltage	V _{IL2}				0.3V _{DD}	V
CMOS Schmitt input level pin *3 High level input voltage	V _{IH4}		0.8V _{DD}			V
CMOS Schmitt input level pin *3 Low level input voltage	V _{IL4}				0.2V _{DD}	V
CMOS Schmitt input level pin *3 Input voltage hysteresis	V _{IH4} to V _{IL4}			0.6		V
TTL Schmitt input level pin *4 High level input voltage	V _{IH5}		2.2V			V
TTL Schmitt input level pin *4 Low level input voltage	V _{IL5}				0.8V	V
TTL Schmitt input level pin *4 Input voltage hysteresis	V _{IH4} to V _{IL4}			0.4		V
Bidirectional pin with pull-up resistor *5 Input current	I _{IL3}	V _{IN} =0V	-90	-200	-440	μA
Pin with pull-up resistor *6 Input current	I _{IL4}	V _{IN} =0V	-40	-100	-240	μA
High level output voltage *7	V _{OH1}	I _{OH} =-2mA	V _{DD} -0.8			V
Low level output voltage *7	V _{OL1}	I _{OL} =-4mA			0.4	V
Input leakage current *8	I _{I1}	V _{IN} =V _{SS} or V _{DD}	-10		10	μA
Output leakage current *9	I _{OZ}	High-impedance state	-40		40	μA
Oscillation cell *10 high level input voltage	V _{IH4}		0.7V _{DD}			V
Oscillation cell low level input voltage	V _{IL4}				0.3V _{DD}	V
Oscillation cell logic threshold value	LV _{TH}			0.5V _{DD}		V
Oscillation cell feedback resistance value	R _{Fb}	V _{IN} =V _{SS} or V _{DD}	250K	1M	2.5M	Ω
Oscillation cell High level output voltage	V _{OH2}	I _{OH} =-3mA	0.5V _{DD}			V
Oscillation cell Low level output voltage	V _{OL2}	I _{OL} =3mA			0.5V _{DD}	V

DC Characteristics

(V_{DD} = 3.5 V, V_{SS} = 0 V, T_{opr} = -20 - 75°C)

Item	Symbol	Conditions	Min.	Typ.	Max.	Unit
TTL input level pin *1 High level input voltage	V _{IH1}		2.2			V
TTL input level pin *1 Low level input voltage	V _{IL1}				0.6	V
CMOS input level pin *2 High level input voltage	V _{IH2}		0.7V _{DD}			V
CMOS input level pin *2 Low level input voltage	V _{IL2}				0.3V _{DD}	V
CMOS Schmitt input level pin *3 High level input voltage	V _{IH4}		0.8V _{DD}			V
CMOS Schmitt input level pin *3 Low level input voltage	V _{IL4}				0.2V _{DD}	V
CMOS Schmitt input level pin *3 Input voltage hysteresis	V _{IH4} to V _{IL4}			0.5		V
TTL Schmitt input level pin *4 High level input voltage	V _{IH5}		2.2V			V
TTL Schmitt input level pin *4 Low level input voltage	V _{IL5}				0.6V	V
TTL Schmitt input level pin *4 Input voltage hysteresis	V _{IH5} to V _{IL4}			0.3		V
Bidirectional pin with pull-up resistor *5 Input current	I _{IL3}	V _{IN} =0V	-20	-50	-110	μA
Pin with pull-up resistor *6 Input current	I _{IL4}	V _{IN} =0V	-10	-25	-60	μA
High level output voltage *7	V _{OH1}	I _{OH} =-1.6mA	V _{DD} -0.8			V
Low level output voltage *7	V _{OL1}	I _{OL} =3.2mA			0.4	V
Input leakage current *8	I _{I1}	V _{IN} =V _{SS} or V _{DD}	-10		10	μA
Output leakage current *9	I _{OZ}	High-impedance state	-40		40	μA
Oscillation cell *10 high level input voltage	V _{IH4}		0.7V _{DD}		V	
Oscillation cell low level input voltage	V _{IL4}				0.3V _{DD}	V
Oscillation cell logic threshold value	LV _{TH}			0.5V _{DD}		V
Oscillation cell feedback resistance value	R _{Fb}	V _{IN} =V _{SS} or V _{DD}	1.2M	2.5M	5M	Ω
Oscillation cell High level output voltage	V _{OH2}	I _{OH} =-1.3mA	0.5V _{DD}			V
Oscillation cell Low level output voltage	V _{OL2}	I _{OL} =1.3mA			0.5V _{DD}	V

- *1. D7 to 0, A4 to 0, XWR, XRD, XCS, MDB7 to 0, MDBP, SD7 to 0, TD7 to 0
- *2. DATA, LRCK, C2PO, EMP, CKSL, RMCK
- *3. BCLK, XRST
- *4. A4 to 0, XWR, XRD, XCS, SDRQ
- *5. D7 to 0, MDB7 to 0, MDBP, SD7 to 0, TD7 to 0
- *6. CKSL
- *7. All output pins except XTL2
- *8. All input pins except *5, *6, and XTL1
- *9. HINT
- *10. Input: XTL1, Output: XTL2

I/O Capacitance

(V_{DD} = V_I = 0 V, f = 1 MHz)

Item	Symbol	Min.	Typ.	Max.	Unit
Input pin	C _{IN}			9	pF
Output pin	C _{OUT}			11	pF
I/O pin	C _{OUT}			11	pF

AC Characteristics ($V_{DD} = 5 V \pm 10\%$, $V_{SS} = 0 V$, $T_{opr} = -20$ to $75^{\circ}C$, output load = 50 pF)

The values in parentheses on the tables for $V_{DD} = 3.5 V$, $V_{SS} = 0 V$, $T_{opr} = -20$ to $75^{\circ}C$, output load = 50 pF. Those without parentheses for $V_{DD} = 5 V \pm 10\%$ and 3.5 V.

1. Sub CPU Interface

(1) Read

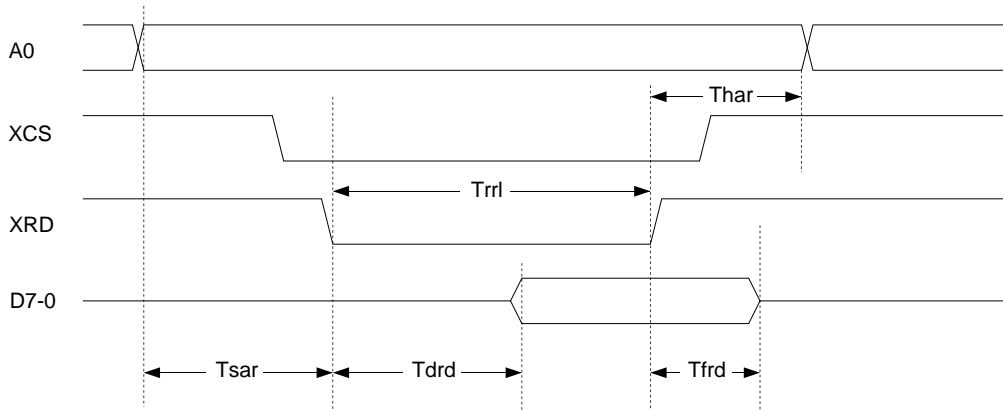

Item	Symbol	Min.	Typ.	Max.	Unit
Address setup time (for XCS & XRD ↓)	Tsar	30 (70)			ns
Address hold time (for XCS & XRD ↑)	Thar	20 (50)			ns
Data delay time (for XCS & XRD ↓)	Tdrd			60 (100)	ns
Data float time (for XCS & XRD ↑)	Tfrd	0		15 (25)	ns
Low level XRD pulse width	Trrl	100 (150)			ns

Note) "&" indicates "AND".

(2) Write

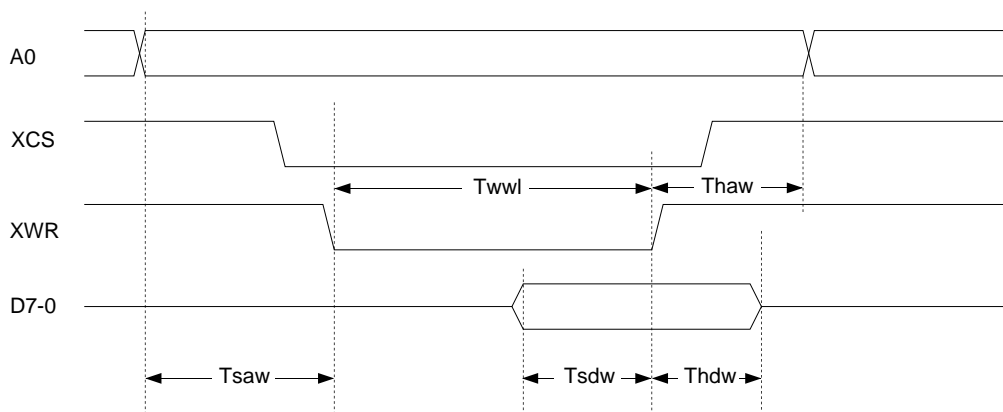

Item	Symbol	Min.	Typ.	Max.	Unit
Address setup time (for XCS & XWR ↓)	Tsaw	30 (70)			ns
Address hold time (for XCS & XWR ↑)	Thaw	20 (50)			ns
Data setup time (for XCS & XWR ↓)	Tsdw	40 (70)			ns
Data hold time (for XCS & XWR ↑)	Thdw	10 (30)			ns
Low level XWR pulse width	Twwl	50 (80)			ns

2. CD DSP Interface

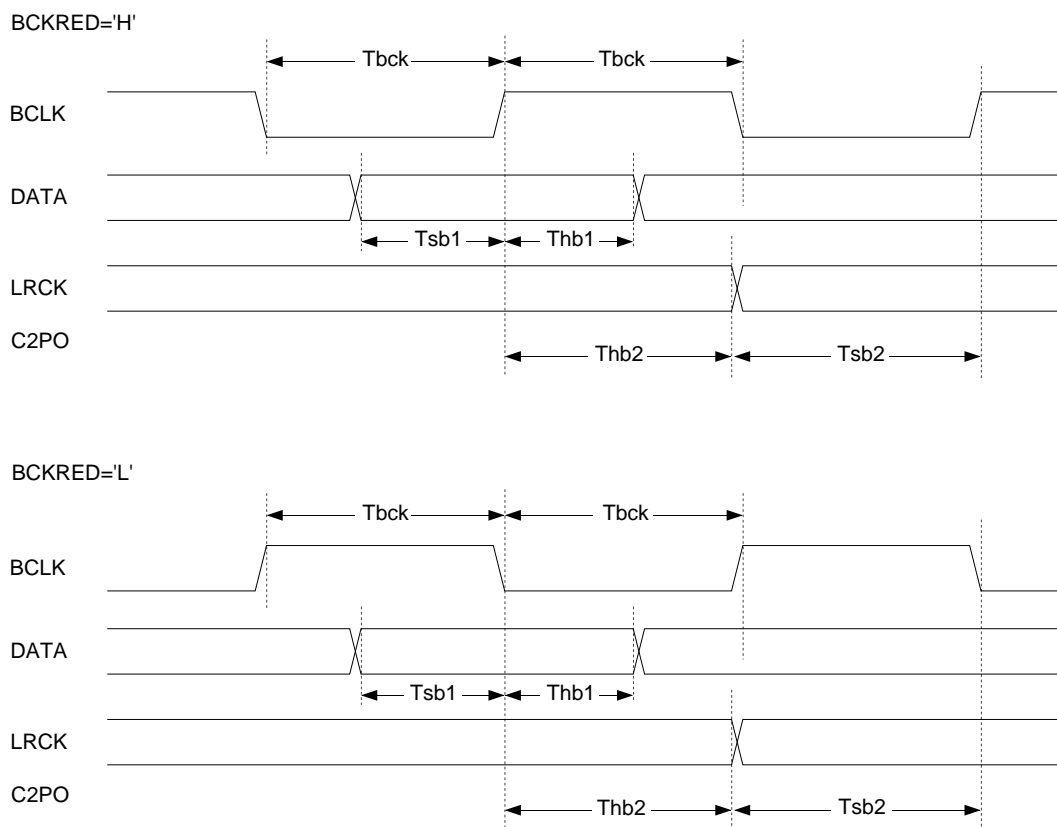

Item	Symbol	Min.	Typ.	Max.	Unit
BCLK frequency	Fbck			11.3	MHz
BCLK pulse width	Tbck	88			ns
DATA setup time (for BCLK)	Tsb1	20			ns
DATA hold time (for BCLK)	Thb1	20			ns
LRCK, C2PO setup time (for BCLK)	Tsb2	20			ns
LRCK, C2PO hold time (for BCLK)	Thb2	20			ns

3. DRAM Interface

(1) Read

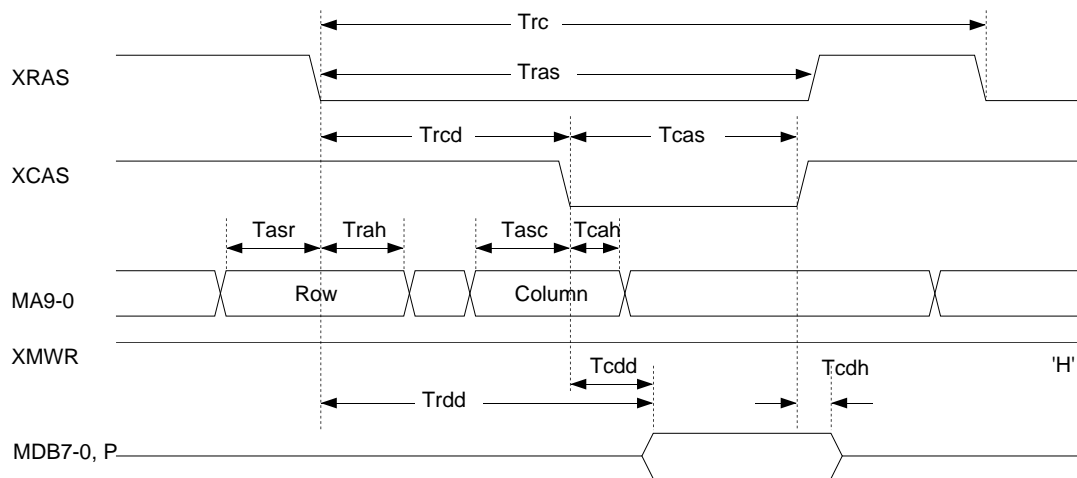

(2) Write

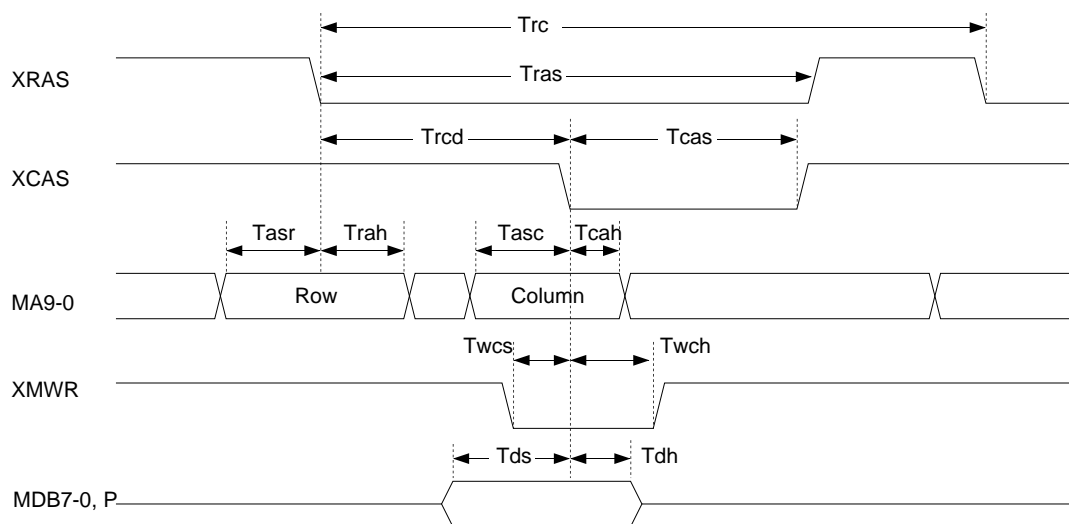

Item	Symbol	Min.	Typ.	Max.	Unit
Random read/write cycle time	Trc		4Tw		ns
RAS pulse width	Tras	2Tw			ns
RAS CAS delay time	Trcd		Tw		ns
CAS pulse width	Tcas	Tw			ns
Row address setup time	Tasr	10			ns
Row address hold time	Trah	20			ns
Column address setup time	Tasc	0			ns
Column address hold time	Tcah	20			ns
Delay time from RAS	Trdd			2Tw-20	ns
Delay time from CAS	Tcdd			Tw-20	ns
Hold time from CAS	Tcdh	0			ns
Write command setup time	Twcs	10			ns
Write command hold time	Twcs	20			ns
Data output setup time	Tds	Tw			ns
Data output hold time	Tds	Tw			ns

4. SRAM Interface

(1) Read

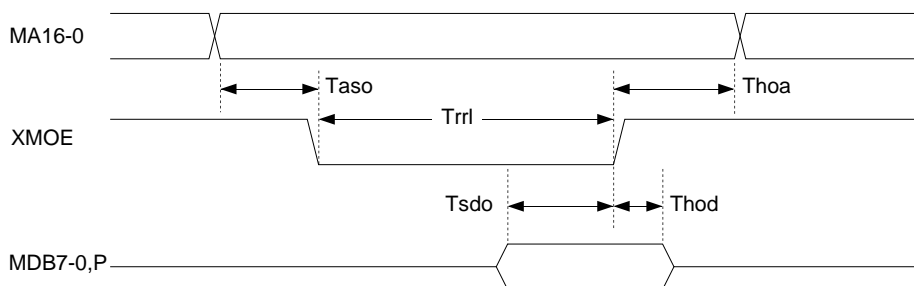

XMWR='H'

Item	Symbol	Min.	Typ.	Max.	Unit
Address setup time (for XMOE ↓)	Tsao	Tw-30			ns
Address hold time (for XMOE ↑)	Thoa	Tw-10			ns
Data setup time (for XMOE ↑)	Tsdo	50 (100)			ns
Data hold time (for XMOE ↑)	Thod	10 (20)			ns
Low level XMOE pulse width	Trrl		2Tw		ns

(2) Write

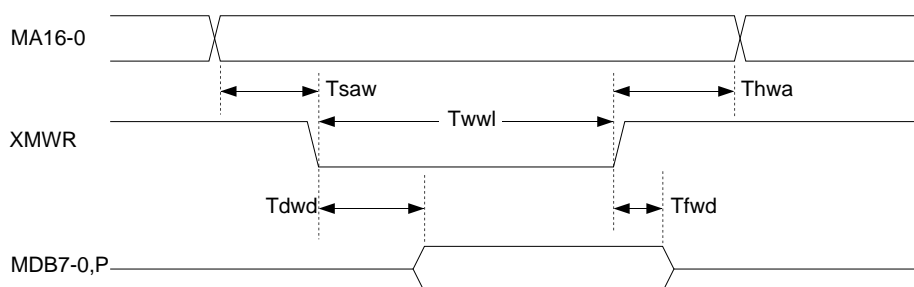

XMOE='H'

Item	Symbol	Min.	Typ.	Max.	Unit
Address setup time (for XMWR ↓)	Tsaw	Tw-30			ns
Address hold time (for XMWR ↑)	Thwa	Tw-10			ns
Data delay time (for XMWR ↓)	Tdwd			10	ns
Data float time (for XMWR ↑)	Tfwd	10			ns
Low level XMWR pulse width	Twwl		2Tw		ns

5. SCSI Controller Interface

(1) Read

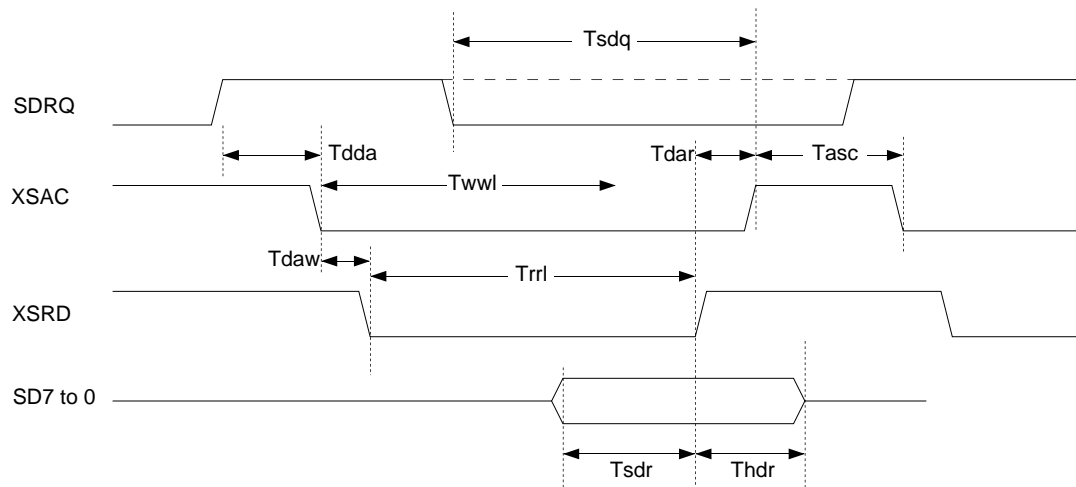

Item	Symbol	Min.	Typ.	Max.	Unit
XSAC fall time (for SDRQ ↑)	Tdda			5×Tw	ns
XSRD delay time (for XSAC ↓)	Tdaw		0		ns
XSAC delay time (for XSRD ↑)	Tdar		Tw		ns
Data setup time (for XSRD ↓)	Tsdr	20 (60)			ns
Data hold time (for XSRD ↑)	Thdr	10 (30)			ns
Low level XSRD pulse width	Trrl		T ₁		ns
SDRQ setup time (for XSAC ↑)	Tsdq	15 (30)			ns
XSAC fall time (for XSAC ↑)	Tsac	Tw			ns

(2) Write

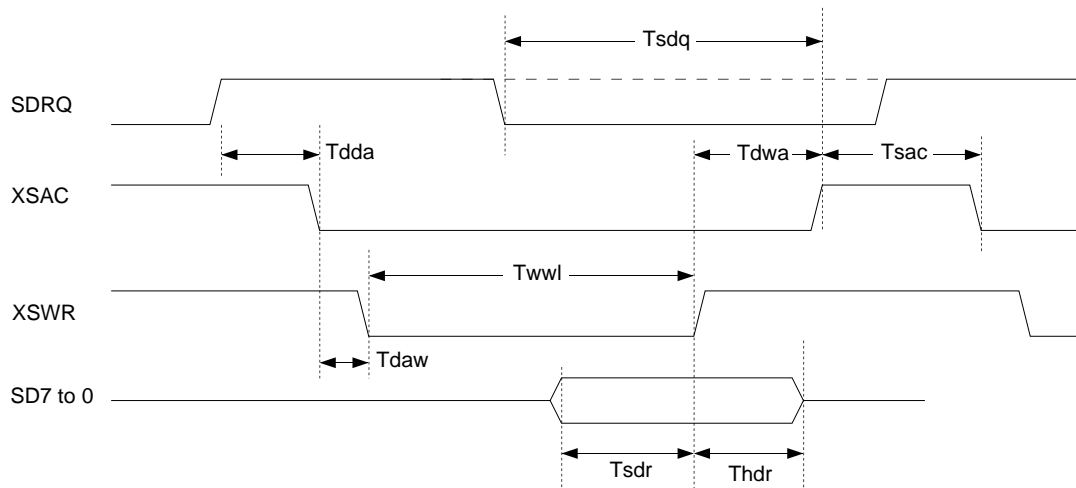

Item	Symbol	Min.	Typ.	Max.	Unit
XSAC fall time (for SDRQ ↑)	Tdda			5×Tw	ns
XSWR delay time (for XSAC ↓)	Tdaw		Tw		ns
XSAC delay time (for XSWR ↑)	Tdwa		Tw		ns
Data setup time (for XSWR ↑)	Tcdr	2×Tw-30			ns
Data hold time (for XSWR ↑)	Thdr	Tw-10			ns
Low level XSWR pulse width	Twwl		T2		ns
SDRQ setup time (for XSAC ↑)	Tsdq	15 (30)			ns
XSAC fall time (for XSAC ↑)	Tsac	Tw			ns

Here:

$$T_1 = \begin{cases} 2 \times Tw: & 3 \text{ cycle mode} \\ 3 \times Tw: & 4 \text{ cycle mode} \\ 4 \times Tw: & 5 \text{ cycle mode} \end{cases}$$

$$T_2 = \begin{cases} Tw: & 3 \text{ cycle mode} \\ 2 \times Tw: & 4 \text{ cycle mode} \\ 3 \times Tw: & 5 \text{ cycle mode} \end{cases}$$

Tw is the CD-ROM decoder clock cycle.

6. DAC Interface

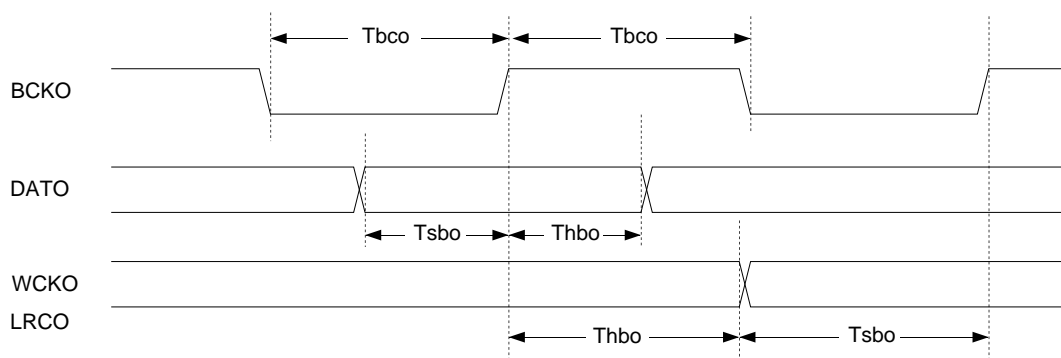

Item	Symbol	Min.	Typ.	Max.	Unit
BCKO frequency	Fbco		8.4672		MHz
BCKO pulse width	Tbco	50			ns
DATO, WCO1, WCO2, LRCO setup time (for BCKO ↑)	Tsbo	30			ns
DATO, WCO1, WCO2, LRCO hold time (for BCKO ↑)	Thbo	30			ns

7. XTL1 and XTL2 Pins

(1) For self-excited oscillation

Item	Symbol	Min.	Typ.	Max.	Unit
Oscillation frequency	Fmax		16.9344		MHz

(2) When a pulse is input to XTL1 pin

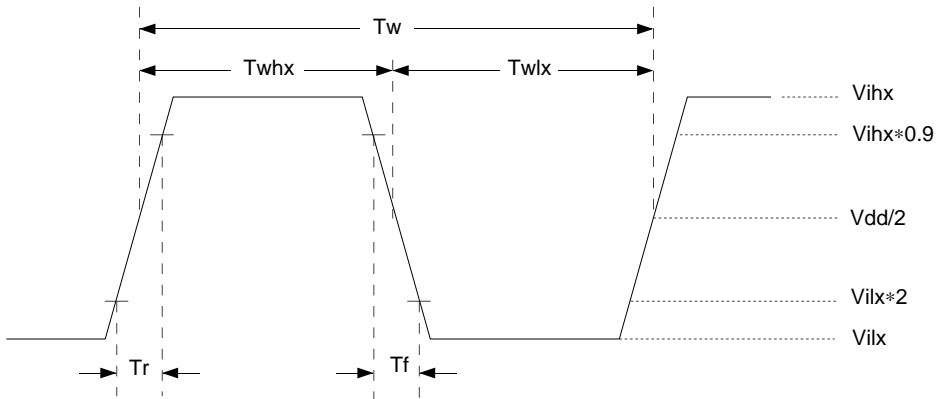

Item	Symbol	Min.	Typ.	Max.	Unit
High level pulse width	T_{whx}	20			ns
Low level pulse width	T_{wlx}	20			ns
Pulse cycle	T_w		59		ns
Input high level	V_{ihx}	$V_{DD}-1.0$			ns
Input low level	V_{ilx}			0.8	ns
Rise time	T_r			15	ns
Fall time	T_f			15	ns

Note: Synchronize the XTL1 clock signal with that of the CD DSP. (Use the clock signal from the same oscillator.)

8. RMCK Pin

Item	Symbol	Min.	Typ.	Max.	Unit
Frequency	frmck			33.3 (23.4)	MHz

Note: The maximum RMCK frequency is 35.0 MHz, when $V_{DD} = 5\text{ V} \pm 5\%$, Playback at quadruple normal speed can be accommodated when a clock signal with a frequency double 16.9344 MHz or more is input to RMCK.

Description of Functions

1. Pin Description

The pin description by function is given below.

1.1. CD player interface (5 pins)

This enables direct connection with the digital signal processor LSI for Sony's CD players. Digital signal processor LSI for CD applications are hereafter called "CD DSP". See 2-1-1 for the data formats.

(1) DATA (DATA: input)

Serial data stream from CD DSP.

(2) BCLK (bit clock: input)

Bit clock signal; data signal strobe.

(3) LRCK (LR clock: input)

LR clock signal; indicates left and right channels of DATA signals.

(4) C2PO (C2 pointer: input)

C2 pointer signal; indicates that an error is contained in DATA input.

(5) EMP (emphasis: input)

Emphasis positive logic signal; indicates that emphasis has been applied to data from CD DSP.

1.2. Buffer memory interface (30 pins)

This is connected with a 32K-byte (256K-bit) or 128K-byte (1M-bit) standard SRAM; also connected with 256K-byte standard DRAM (two DRAMs of 128K-byte).

(1) XMWR (buffer memory write: output)

Data write strobe negative logic output signal to buffer memory.

(2) XMOE/XCAS (buffer memory output enable/column address strobe: output)

When connected to SRAM, data read strobe negative logic output signal to buffer memory.

When connected to DRAM, XCAS (column address strobe negative logic) signal.

(3) MA0 to 15 (buffer memory address: output)

Address signals to buffer memory. When connected to DRAM, MA0 to 8 are valid.

(4) MA16/XRAS (buffer memory address/row address strobe: output)

When connected to SRAM, address signal to buffer memory. XRAS (row address strobe negative logic) signal when connected to DRAM.

(5) XME0, 1 (buffer memory chip enable: output)

When connected to a chip SRAM, chip enable negative logic signal to buffer memory. Not used when connected to DRAM.

(6) MDB0 to 7, P (buffer memory data bus: bus)

Data bus signals to buffer memory; pulled up by standard 25k Ω resistor; MDBP pin is left open when connected to an 8-bit/word SRAM.

(7) DRAM (buffer memory DRAM: input)

High is input when DRAM is connected as buffer memory.

Low is input when SRAM is connected as buffer memory.

1.3. Sub CPU interface (17 pins)

- (1) XWR (sub CPU write: input)
Strobe negative logic input signal for writing IC internal register.
- (2) XRD (sub CPU read: input)
Strobe negative logic input signal for reading IC internal register status.
- (3) D0 to 7 (sub CPU data bus: input/output)
8-bit data bus.
- (4) A0 to 4 (sub CPU address: input)
Address signal for selecting IC internal register from sub CPU.
- (5) XINT (sub CPU interrupt: output)
Interrupt request negative logic signal to sub CPU.
- (6) XCS (chip select: input)
IC select negative logic signal from sub CPU.

1.4. SCSI controller interface (13pins)

- (1) SDRQ (SCSI data request: input)
DMA data request positive logic signal from SCSI controller IC.
- (2) XSAC (SCSI DMA acknowledge: output)
DMA acknowledge negative logic signal to SCSI controller IC.
- (3) XSWR (SCSI write: negative logic output)
Data write strobe output to SCSI controller IC.
- (4) XSRD (SCSI read: negative logic output)
Data read strobe output to SCSI controller IC.
- (5) SD0 to 7 (SCSI controller bus: input/output)
SCSI controller data bus signal.

1.5. DAC interface (4 pins)

The output format to DAC is shown in Fig. 1-1.

- (1) BCKO (bit clock output: output)
Bit clock output signal to D/A converter.
- (2) WCKO (word clock output: output)
Word clock output signal to D/A converter.
- (3) LRCO (LR clock output: output)
LR clock output signal to D/A converter.
- (4) DATO (data output: output)
Data output signal to D/A converter.

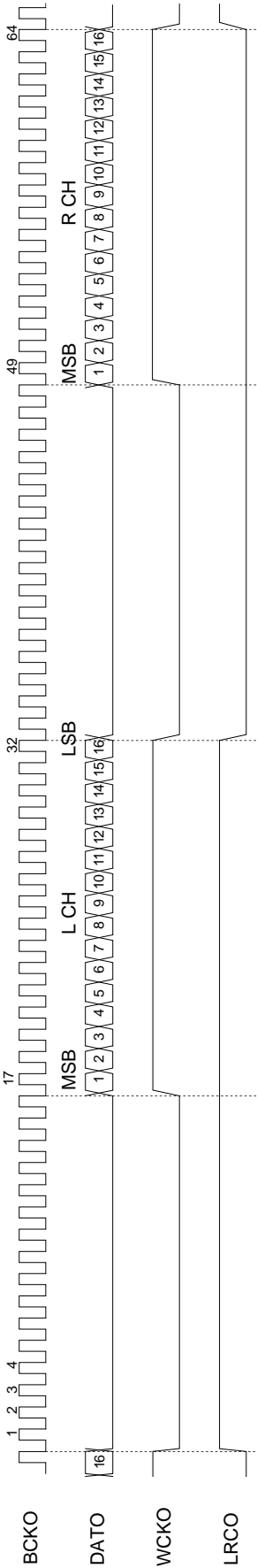

Fig. 1-1 Output Format to D/A Converter

1.6. Others (16 pins)

(1) MUTE (mute: output)

Outputs high when DA data (DATO) is muted.

(2) XRST (reset: input)

Chip reset negative logic input signal.

(3) XTL1 (crystal 1: input)

(4) XTL2 (crystal 2: output)

A 16.9344 MHz crystal oscillator is connected between XTL1 and XTL2. (The capacitor value depends on the crystal oscillator.)

Alternatively, a 16.9344 MHz clock signal is input to the XTL1 pin.

(5) CLK (clock: output)

Outputs a 16.9344 MHz clock signal. The output can be fixed low when this signal is not used.

(6) HCLK (half clock: output)

Outputs an 8.4672 MHz clock. The output can be fixed low when this signal is not used.

(7) CKSL (clock select: input)

High or open: The IC is operated by the XTL1 clock.

Low: The audio block (ADPCM decoder and digital filter) is operated by the XTL1 clock, and the CD-ROM decoder block is operated by the RMCK clock.

This pin is pulled up by a standard 50k Ω resistor in the IC .

(8) RMCK (ROM clock: input)

When the CKSL pin is set low, the clock of the CD-ROM decoder block is input. When it is high or left open, fix the RMCK pin high or low.

(9) TD0 to 5 (test data 0 to 5: input/output)

Data pins for testing the IC . They are pulled up by a 25k Ω standard resistor and are normally left open.

2. Sub CPU Registers

2.1. Write registers

2.1.1. DRVIF (drive interface) register

This register controls the connection mode with the CD DSP. After the IC is reset, the sub CPU sets this register according to the CD DSP to be connected.

bit 7: C2PL1ST (C2PO lower byte first)

High: When two bytes of data are input, C2PO inputs the lower byte first followed by the upper byte.

Low: When two bytes of data are input, C2PO inputs the upper byte first followed by the lower byte.

Here, "upper byte" means the upper 8 bits including MSB from the CD DSP and "lower byte" means the lower 8 bits including LSB from the CD DSP. For example, the header minute byte is the lower byte and the second byte, the upper byte.

bit 6: LCHLOW (Lch low)

High: When LRCK is low, determined to be the left channel data.

Low: When LRCK is high, determined to be the left channel data.

bit 5: BCKRED (BCLK rising edge)

High: Data is strobed at the rising edge of BCLK.

Low: Data is strobed at the falling edge of BCLK.

bits 4,3: BCKMD1, 0 (BCLK mode1, 0)

These bits are set according to the number of clocks output for BCLK during one WCLK cycle by the CD digital signal processing LSI (CD DSP).

BCKMD1	BCKMD0	
'L'	'L'	16BCLKs/WCLK
'L'	'H'	24BCLKs/WCLK
'H'	'X'	32BCLKs/WCLK

bit 2: LSB1ST (LSB first)

High: Connected with the CD DSP which outputs data with LSB first.

Low: Connected with the CD DSP which outputs data with MSB first.

bits 1,0: Reserved

Normally set low.

Any change of each bit in this register must be made in the decoder disable status. Table 2-1-1 indicates the setting values for bits 7 to 2 when this IC is connected to Sony's CD DSP.

Figs. 2-1-1(1) to (3) are input timing charts.

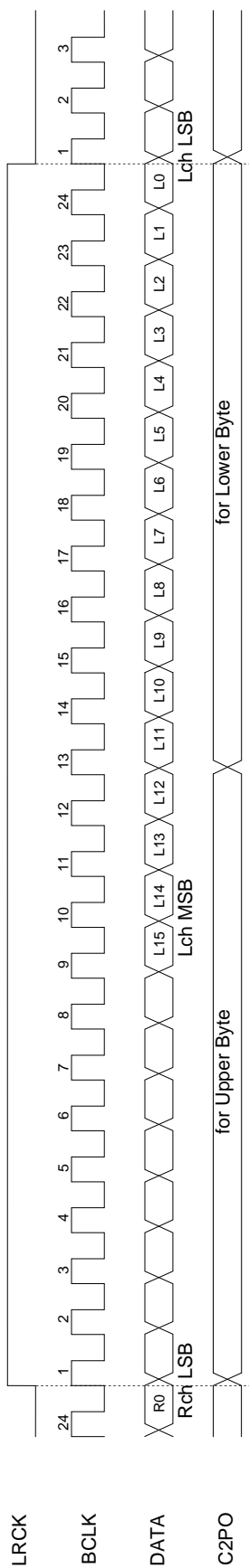

Fig. 2-1-1 (1) CDL30 and 35 Series Timing Chart

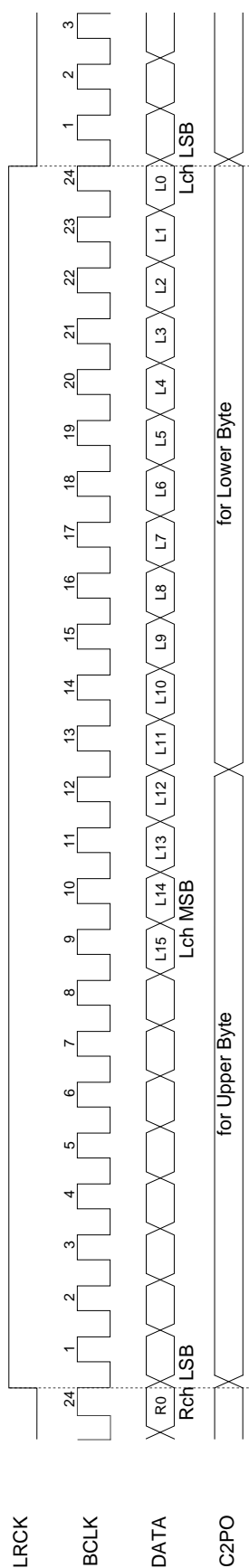

Fig. 2-1-1 (2) CDL40 Series Timing Chart (48-bit slot mode)

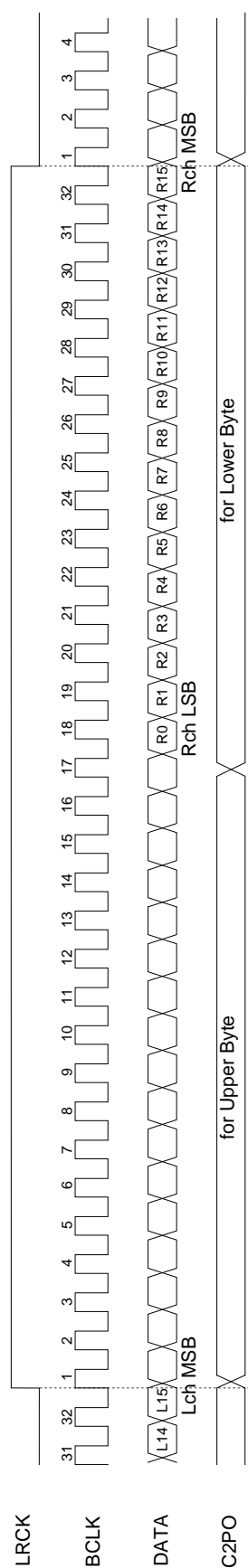

Fig. 2-1-1 (3) CDL40 Series Timing Chart (64-bit slot mode)

Table 2-1-1 DRVIF Register Settings

Sony CD DSP	DR VIF register						Timing chart
	bit7	bit6	bit5	bit4	bit3	bit2	
	c2po	lrck	bedg	bck1	bck0	lsb	
CDL30 Series CDL35 Series	L	L	L	L	H	L	Fig. 2-1-1(1)
CDL40 Series (48-bit slot mode)	L	L	H	L	H	L	Fig. 2-1-1 (2)
CDL40 Series (64-bit slot mode)	L	H	L	H	X	H	Fig. 2-1-1(3)

Note 1)

CDL30 Series	CXD1125Q/QZ, CXD1130Q/QZ, CXD1135Q/QZ CXD1241Q/QZ, CXD1245Q, CXD1246Q/QZ CXD1247Q/QZ/R, etc.
CDL35 Series	CXD1165Q, CXD1167Q/QZ/R, etc.
CDL40 Series	CXD2500Q/QZ, etc.

2.1.2. CONFIG1 (configuration 1) register

This register is set depending on the IC peripheral hardware. The sub CPU sets this register after the IC is reset.

bit 7: Reserved

Normally set low.

bit 6: XSLOW

The number of clock signals per DMA1 cycle is determined by this bit.

High: 4 clock signals

Low: 12 clock signals

Set low when a low-speed SRAM is connected for $V_{DD} = 3.5$ V.

When XSLOW is low, erasure correction and double speed playback are prohibited.

bit 5: Reserved

Normally set low.

bits 4,3: RAMSZ1, 0 (RAM size 1, 0)

bit 2: 9BITRAM

These bits are set depending on the size of the buffer memory connected to the IC.

RAMSZ1	RAMSZ0	9BITRAM	Memory size
'L'	'L'	'L'	32K ^w ×8 ^b
'L'	'L'	'H'	32K ^w ×9 ^b
'L'	'H'	'L'	64K ^w ×8 ^b
'L'	'H'	'H'	64K ^w ×9 ^b
'H'	'L'	'L'	128K ^w ×8 ^b
'H'	'L'	'H'	128K ^w ×9 ^b
'H'	'H'	'L'	256K ^w ×8 ^b
'H'	'H'	'H'	256K ^w ×9 ^b

Refer to Chapter 3 for information on buffer memory connection.

- bit 1: CLKDIS (CLK disable)
 High: The CLK pin is fixed low.
 Low: A 16.9344 MHz clock signal is output from the CLK pin.
- bit 0: HCLKDIS (half CLK disable)
 High: The HCLK pin is fixed low.
 Low: An 8.4672 MHz clock signal is output from the HCLK pin.

2.1.3. CONFIG2 (configuration 2) register

This register is set depending on the IC peripheral hardware. The sub CPU sets this register after the IC has been reset.

bits 7, 6: SCYC1, 0 (SCSI DMA cycle 1, 0)

Data transfer between the IC and the SCSI control IC is executed by the following number of clock signals.

SCYC1	SCYC0	
'L'	'L'	3 clock signals
'L'	'H'	4 clock signals
'H'	'X'	5 clock signals

- bit 5: SPECTL (sound parameter error control)
- bit 4: SPMCTL (sound parameter majority control)
 These two bits control the processing of the sound parameters for ADPCM playback.
- bit 3: SMBF2 (sound map buffer 2)
 Indicates the number of buffer surfaces for the sound map ADPCM.
 High: 2 buffer surfaces for the sound map
 Low: 3 buffer surfaces for the sound map
- bit 2: DAMIXDIS (digital audio mixer disable)
 High: Attenuator and mixer are not activated for CD-DA.
 Low: Attenuator and mixer are activated for CD-DA.
- bit 1: DACOUTEN (DAC out enable)
 High: Clock signals are output from the WCKO, LRCO and BCKO pins even for muting.
 Low: The WCKO, LRCO and BCKO pins are set low for muting.
- bit 0: PRYCTL (priority control)
 When double speed playback with erasure correction is carried out with the CD-ROM decoder clock frequency at 18 MHz or less, this bit goes high. In this case, priority is given to buffer access for ECC, and the data transfer rate to the SCSI controller drops.

2.1.4. DECCTL (decoder control) register

bit 7: ENDLADR (enable drive last address)

High: DLADR (drive last address) is enabled when this is set high. When DADRC and DLADR become equal while the decoder is in the write-only, real-time correction or CD-DA mode, the data writing from the drive into the buffer is stopped.

Low: DLADR (drive last address) is disabled when this is set low. Even when DADRC and DLADR become equal while the decoder is in the write-only, real-time correction or CD-DA mode, the data writing from the drive into the buffer is not stopped.

bit 6: ECCSTR (ECC strategy)

High: Errors are corrected with consideration given to the error flags of the data.

Low: Errors are corrected with no consideration given to the error flags of the data. In this case, there is no erasure correction. Set this bit low when the IC is connected to an 8-bit/word SRAM.

bit 5: MODESEL (mode select)

bit 4: FORMSEL (form select)

When AUTODIST is low, the sector is corrected in the MODE or FORM indicated below.

MODESEL	FORMSEL	
'L'	'L'	MODE1
'H'	'L'	MODE2, FROM1
'H'	'H'	MODE2, FROM2

bit 3: AUTODIST (auto distinction)

High: Errors are corrected according to the MODE byte and FORM bit read from the drive.

Low: Errors are corrected according to the MODESEL and FORMSEL bits (bits 5 and 4).

bits 2 to 0: DECMD2 to 0 (decoder mode 2 to 0)

DECMD2	DECMD1	DECMD0	
'L'	'L'	'X'	Decoder disable
'L'	'H'	'X'	Monitor-only mode
'H'	'L'	'L'	Write-only mode
'H'	'L'	'H'	Real-time correction mode
'H'	'H'	'L'	Repeat correction mode
'H'	'H'	'H'	CD-DA mode

When the CD-DA bit (bit 4) in the CHPCTL register is to be set high, set the decoder to the disable or CD-DA mode.

2.1.5. DLADR-L

2.1.6. DLADR-M

2.1.7. DLADR-H

While the decoder is in the write-only, real-time correction or CD-DA mode, the last address is set for the buffer write data from the drive. When the ENDLADR bit (bit 7) of the DECCTL register is high and the data from the drive is written into the address assigned by DLADR while the decoder is in any of the above modes, all subsequent writing in the buffer is prohibited.

2.1.8. CHPCTL (chip control) register

bit 7: SM MUTE (sound map mute)

When this is set high, the audio output is muted for sound map ADPCM playback.

bit 6: RT MUTE (real time mute)

When this is set high, the audio output is muted for real-time ADPCM playback.

bit 5: CD-DA MUTE

When bit 4 is high and this bit is also set high for a CD-DA (digital audio) disc playback, the audio output is muted. When bit 4 is low, this bit has no effect on the audio output.

bit 4: CD-DA

High: Set high for playing back the audio signals of a CD-DA disc. Setting this bit high is prohibited for ADPCM decode playback.

Low: Set low for not playing back the audio signals of a CD-DA disc.

bit 3: SWOPEN (sync window open)

High: A window for sync mark detection is opened. In this case, the sync protection circuit in the IC is disabled.

Low: The window for sync mark detection is controlled by the sync protection circuit in the IC.

bit 2: RPSTART (repeat correction start)

Sector error correction starts when the decoder is set to the repeat correction mode, making this bit high. This bit is automatically set low when correction starts. Therefore, there is no need for the sub CPU to reset low.

bit 1: DBLSPD (double speed)

Set high for double speed playback. Before changing the bit value, switch the CD DSP mode (normal speed playback or double speed playback).

bit 0: Reserved

Normally set low.

2.1.9. WRDATA (CPU buffer write data)

The data written in this register is written in the buffer.

2.1.10. INTMSK (interrupt mask) register

By setting each bit of this register high, the interrupt request from the IC to the sub CPU is enabled depending on the corresponding interrupt status. (In other words, the INT pin is made active when its interrupt status is established.) The value of each bit in this register does not affect the corresponding interrupt status.

bit 7: DRVOVRN (drive overrun)

The DRVOVRN status is established when the ENDLADR bit (bit 7) of the DECCTL register is set high, and DADRC and DLADR become equal while the decoder is in the write-only or real-time correction mode. It is also established when they become equal while the decoder is in the CD-DA mode regardless of the ENDLADR bit value.

bit 6: DECTOUT (decoder time out)

The DECTOUT status is established when the sync mark is not detected even after the time it takes to search 3 sectors (40.6 ms at normal speed playback) has elapsed after the decoder has been set to the monitor-only, write-only or real-time correction mode.

bit 5: Reserved

Normally set low.

bit 4: RTADPEND (real time ADPCM end)

The RTADPEND status is established when real-time ADPCM decoding is completed for one sector.

bit 3: HDMACMP (host DMA complete)

The HDMACMP status is established when DMA is completed by HXFRC.

bit 2: DECINT (decoder interrupt)

The DECINT status is established when the sync mark is detected or inserted while the decoder is in the write-only, monitor-only or real-time correction mode. However, it is not established if the sync mark interval is less than 2352 bytes while the window for its detection is open. The status is established each time one correction is completed when the decoder is in the repeat correction mode.

bit 1: BFWRDY (buffer write ready)

The BFWRDY status is established when there is more than one sector available for buffer write when the decoder is in the sound map playback mode. The status is also established for any of the following.

- (1) The sub CPU makes the DMACTL register SMEN bit high.
- (2) When there is more than one sector of sound map data area after one sector of sound map data is written into buffer memory from the SCSI controller (not buffable).
- (3) When there is an area for sound map data writing on the buffer memory because one sector of sound map ADPCM decoding has been completed.

bit 0: BFEMPT (buffer empty)

The BFEMPT status is established when there is no subsequent sector data on the buffer memory after one sector of ADPCM decoding is completed during sound map playback.

2.1.11. CLRCTL (clear control) register

When each bit of the register is set high, the corresponding chip, status, register, interrupt status and ADPCM playback are cleared. After clearing, the bit concerned is automatically set low. Therefore, there is no need for the sub CPU to reset low.

bit 7: CHPRST (chip reset)

The inside of the IC is initialized when this bit is set high. This bit is automatically set low upon completion of the initialization.

bits 6, 5: Reserved

Normally set low.

bit 4: RTADPCLR (real time ADPCM clear)

(1) When this is set high for real-time ADPCM playback (when the RTADPBSY bit of the DECSTS register is high):

- ADPCM decoding for playback is suspended. (Noise may be generated.)
- The RTADPEND interrupt status is established.

(Note) The ADPEN bit (bit 7 of the ADPMNT register) must be set low before this bit is set high.

(2) Setting this bit high when real-time ADPCM playback is not being performed has no effect whatsoever.

bit 3: SMADPCLR (sound map ADPCM clear)

(1) When this is set high for sound map ADPCM playback (when the SMADPBSY bit of the DECSTS register is high):

- ADPCM decoding for playback is suspended. (Noise may be generated.)
- The RTADPEND interrupt status is established.

(2) Setting this bit high when sound map ADPCM playback is not being performed has no effect whatsoever.

bit 2: Reserved

Normally set low.

bit 1: PDATA (pointer data)

The data written to this bit is written in the buffer pointer bit along with the WRDATA register value.

bit 0: RESYNC

The CD DSP and this IC are re-synchronized when this bit is set high. Set the bit high by the sub CPU in the following cases:

- (1) After the DRVIF register has been set
- (2) After the DBLSPD bit (bit 1 of the CHPCTL register) has been set low.

This bit is automatically set low when the CD DSP and this IC are re-synchronized.

2.1.12. CLRINT (clear interrupt status) register

When each bit of this register is set high, the corresponding interrupt status is cleared. The bit concerned is automatically set low after its interrupt status has been cleared. Therefore, there is no need for the sub CPU to reset low.

- bit 7: DRVOVRN (drive overrun)
- bit 6: DECTOUT (decoder time out)
- bit 5: Reserved
Normally set low.
- bit 4: RTADPEND (real time ADPCM end)
- bit 3: HDMACMP (host DMA complete)
- bit 2: DECINT (decoder interrupt)
- bit 1: BFWRDY (buffer write ready interrupt)
- bit 0: BFEMPT (buffer write empty interrupt)

2.1.13. HXFR-L (host transfer-low)

2.1.14. HXFR-H (host transfer-high)

- bit 7: DISHXFRC (disable host transfer counter)
High: The completion of the data transfer by HXFRC is disabled for data transfer between the SCSI controller and buffer memory.
Low: The completion of the data transfer by HXFRC is enabled for data transfer between the SCSI controller and buffer memory.
- bit 6: Reserved
- bit 5: HADR17
HADR bit 17 (MSB)
- bit 4: HADR16
HADR bit 16
- bit 3: HXFR11
HXFR (host transfer counter) bit 11 (MSB)
- bit 2: HXFR10
HXFR bit 10
- bit 1: HXFR9
HXFR bit 9
- bit 0: HXFR8
HXFR bit 8

The HXFR (host transfer) register sets the number of data transferred between the SCSI controller and buffer memory. The sub CPU sets this number when data is transferred between the SCSI controller and buffer memory by setting the DISHXFRC bit low.

2.1.15. HADR-L (host address-low)

2.1.16. HADR-M (host address-middle)

The HADR (host address) register is for the head addresses of data transfer between the SCSI controller and buffer memory. The upper two HADR bits are in HXFR-H.

2.1.17. DADRC-L

This counter keeps the address for writing the data from the drive into the buffer. When drive data is written into the buffer, the DADRC value is output from MA0 to 17 (when SRAM is connected). DADRC is incremented each time 1 byte of data is written from the drive into the buffer.

The sub CPU sets the head address for buffer writing into DADRC before the decoder operates in the write-only, real-time correction or CD-DA mode.

The sub CPU can set DADRC at any time. The contents of DADRC should not be changed while the decoder is operating in any of the above modes.

2.1.18. DADRC-M

2.1.19. DADRC-H

2.1.20. CADRC-L

This counter keeps the address for writing/reading the data from the sub CPU into the buffer. When drive data is written into the buffer, the DADRC value is output from MA0 to 17 (when SRAM is connected). DADRC is incremented each time 1 byte of data is written from the drive into the buffer.

The sub CPU can set CADRC at any time.

2.1.21. CADRC-M

2.1.22. CADRC-H

bit 7: Reserved

bit 6: CPU SRC (sub CPU source)

This bit is set high when the sub CPU writes data into the buffer. It is set low when the sub CPU reads data from the buffer.

bit 5: CDMAEN (sub CPU DMA enable)

This bit is set high when the sub CPU reads or writes data in the buffer memory.

bits 4 to 2: Reserved

bit 1: CADRC bit 17 (MSB)

bit 0: CADRC bit 16

2.1.23. DMACTL (DMA control)

bit 7: BFRD (buffer read)

Transfer of (drive) data from the buffer memory to the SCSI controller begins when this bit is set high. The bit is automatically set low after transfer is completed.

bit 6: BFWR (buffer write)

Transfer of data from the SCSI controller to buffer memory begins when this bit is set high. The bit is automatically set low after transfer is completed.

bit 5: SMEN (sound map enable)

Set high when sound map ADPCM playback is performed.

bits 4 to 0: Reserved

The sub CPU must set these bits low.

2.1.24. SMCI

Writes the coding information bytes when sound map ADPCM playback is performed.

- bit 6: EMPHASIS
Set high when an ADPCM sector where emphasis has been applied is played back.
- bit 4: BITLENGTH (bit length)
Indicates the bit length of the coding information for ADPCM playback.
High: 8 bits
Low: 4 bits
- bit 2: FS (sampling frequency)
Indicates ADPCM playback sampling frequency.
High: 18.9 kHz
Low: 37.8 kHz
- bit 0: S/M (stereo/monaural)
Indicates the coding information stereo or monaural for ADPCM playback.
High: stereo
Low: monaural
- bits 7, 5, 3, 1: Reserved
Normally set low.

2.1.25. ADPMNT

- bit 7: RTADPEN (real-time ADPCM enable)
The sub CPU sets this high to perform real-time ADPCM playback.
- bits 6 to 0: The upper 7 bits (bits 16 to 10) of the sector head address are written into these bits to perform real-time ADPCM playback. ADPMNT bit 17 is in RTCI register bit 1. Any of the following values can be written into this register: 00, 0C, 18, 24, 30, 3C, 54HEX (when connected to 32K-byte buffer memory).

2.1.26. RTCI

Writes the coding information bytes when real-time ADPCM playback is performed.

- bit 6: EMPHASIS
Set high when an ADPCM sector where emphasis has been applied is played back.
- bit 4: BITLENGTH (bit length)
Indicates the bit length of the coding information for ADPCM playback.
High: 8 bits
Low: 4 bits
- bit 2: FS (sampling frequency)
Indicates sampling frequency of ADPCM playback.
High: 18.9 kHz
Low: 37.8 kHz
- bit 1: ADPMNT17
ADPMNT bit 17 (MSB)
- bit 0: S/M (stereo/monaural)
Indicates the coding information stereo or monaural for ADPCM playback.
High: stereo
Low: monaural
- bits 7, 5, 3: Reserved
Normally set low.

2.1.27. ATV (attenuation value) register 0

2.1.28. ATV (attenuation value) register 1

2.1.29. ATV (attenuation value) register 2

2.1.30. ATV (attenuation value) register 3

The attenuation values are set in these registers.

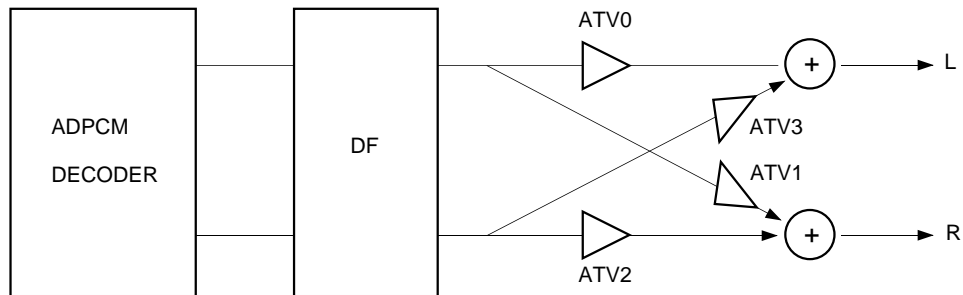

Setting 81HEX or higher in these registers is prohibited. When bits 7 to 0 of these registers are "b7" to "b0", the attenuation (dB) is as follows:

$$\text{Attenuation} = 20 \log (b7 \times 2^0 + b6 \times 2^{-1} + b5 \times 2^{-2} + b4 \times 2^{-3} + b3 \times 2^{-4} + b2 \times 2^{-5} + b1 \times 2^{-6} + b0 \times 2^{-7})$$

The relationship expressed in the above formula and ATV register settings are given in the following table.

Setting	Attenuation	Setting	Attenuation	Setting	Attenuation
80	0.00	55	3.56	2A	9.68
7F	0.07	54	3.66	29	9.89
7E	0.14	53	3.76	28	10.10
7D	0.21	52	3.87	27	10.32
7C	0.28	51	3.97	26	10.55
7B	0.35	50	4.08	25	10.78
7A	0.42	4F	4.19	24	11.02
79	0.49	4E	4.30	23	11.26
78	0.56	4D	4.41	22	11.51
77	0.63	4C	4.53	21	11.77
76	0.71	4B	4.64	20	12.04
75	0.78	4A	4.76	1F	12.32
74	0.86	49	4.88	1E	12.60
73	0.93	48	5.00	1D	12.90
72	1.01	47	5.12	1C	13.20
71	1.08	46	5.24	1B	13.52
70	1.16	45	5.37	1A	13.84
6F	1.24	44	5.49	19	14.19
6E	1.32	43	5.62	18	14.54
6D	1.40	42	5.75	17	14.91
6C	1.48	41	5.89	16	15.30
6B	1.56	40	6.02	15	15.70
6A	1.64	3F	6.16	14	16.12
69	1.72	3E	6.30	13	16.57
68	1.80	3D	6.44	12	17.04
67	1.89	3C	6.58	11	17.54
66	1.97	3B	6.73	10	18.06
65	2.06	3A	6.88	0F	18.62
64	2.14	39	7.03	0E	19.22
63	2.23	38	7.18	0D	19.87
62	2.32	37	7.34	0C	20.56
61	2.41	36	7.50	0B	21.32
60	2.50	35	7.66	0A	22.14
5F	2.59	34	7.82	09	23.06
5E	2.68	33	7.99	08	24.08
5D	2.77	32	8.16	07	25.24
5C	2.87	31	8.34	06	26.58
5B	2.96	30	8.52	05	28.16
5A	3.06	2F	8.70	04	30.10
59	3.16	2E	8.89	03	32.60
58	3.25	2D	9.08	02	36.12
57	3.35	2C	9.28	01	42.14
56	3.45	2B	9.47	00	∞

Relationship between ATV register settings and attenuation amounts

All written registers, except the ATV0 and ATV2 registers, are 00HEX when the IC is reset (both hard and soft reset). The ATV0 and ATV2 registers are 80HEX when the IC is reset. "Hard reset" means that the XRST pin is set low. "Soft reset" means that the sub CPU resets the IC.

2.2. Read registers

In the descriptions of the ECCSTS, DECSTS, HDRFLG, HCR, SHDR and CMADR-H registers, the current sector denotes the sector for which these registers are valid for the decoder interrupt (DECINT). In the monitor-only or write-only mode, the sector sent from the CD DSP immediately before the decoder interrupt is called the current sector. In the real-time correction mode and repeat correction mode, the current sector is that in which error detection correction has been completed.

2.2.1. ECCSTS (ECC status)

bit 7: EDCALL0 (EDC ALL 0)

This is high when there are no error flags in all the 4 EDC parity bytes of the current sector and their values are all 00h.

bit 6: ERINBLK (erasure in block)

(1) When the decoder is operating in the monitor-only, write-only or real-time mode which prohibits erasure correction, this indicates that at least a 1-byte error flag (C2PO) has been raised in the data excluding the sync mark from the current sector CD DSP.

(2) When the decoder is operating in the real-time correction mode which performs erasure correction, this indicates that at least a 1-byte error flat (MDBP) has been raised in the data excluding the sync mark from the current sector CD DSP.

bit 5: CORINH (correction inhibit)

This is high if the current sector MODE and FORM could not be determined when the AUTODIST bit of the DECCTL register is set high. ECC or EDC is not executed in this sector. The CORINH bit is invalid when AUTODIST is set low. It is high in any of the conditions below when the AUTODIST bit is set high.

(1) When the C2 pointer of the MODE byte is high

(2) When the MODE byte is a value other than 01HEX or 02HEX.

(3) When the MODE byte is 02HEX and the C2 pointer is high in the submode byte

bit 4: CORDONE (correction done)

Indicates that there is an error corrected byte in the current sector.

bit 3: EDCOK

Indicates that an EDC check has found no errors in the current sector.

bit 2: ECCOK

Indicates that there are no more errors from the header byte to P parity byte in the current sector. (Bit 2 = don't care in the MODE2, FORM2 sectors.)

EDCOK	ECCOK	Description
L	L	Error(s) present in current sector
L	H	(1), (2) or (3) applies: (1) ECD overlooked (2) Error corrected (3) Error(s) present in header byte with FORM2
H	L	(1) EDC overlooked, or (2) Error(s) present in P parity byte
H	H	No error(s) in current sector

bit 1: CMODE (correction mode)

bit 0: CFORM (correction form)

Indicates the MODE and FORM of the current sector whom the decoder has discriminated to correct errors when the decoder is operating in the real-time correction or repeat correction mode.

CFORM	CMODE	
'X'	'L'	MODE1
'L'	'H'	MODE2, FORM1
'H'	'H'	MODE2, FROM2

2.2.2. DECSTS (decoder status) register

bit 1: SHRTSCT (short sector)

Indicates that the sync mark interval was less than 2351 bytes. This sector does not remain in the buffer memory.

bit 0: NOSYNC

Indicates that the sync mark was inserted because one was not detected in the prescribed position.

2.2.3. HDRFLG (header flag) register

Indicates the error flags of the header and sub header register bytes.

2.2.4. HDR (header) register

This is a 4-byte register which indicates the current sector header byte. By setting the address to 03HEX and reading out the data in sequence, the sub CPU can ascertain the values of the current sector header bytes from the MINUTE byte.

2.2.5. SHDR (sub header) register

This is a 4-byte register which indicates the current sector sub header byte. By setting the address to 04HEX and reading out the data in sequence, the sub CPU can ascertain the values of the current sector sub header bytes from the File byte.

The contents of the HDRFLG, HDR and SHDR registers indicate:

- (1) The corrected value in the real-time correction or repeat correction mode
- (2) Value of the raw data from the drive in the monitor-only or write-only mode

The CFORM and CMODE bits (bits 1, 0) of DECSTS indicate the FORM and MODE of the sector the decoder has discriminated by the raw data from the drive. Due to erroneous corrections, the values of these bits may be at variance with those of the HDR register MODE byte and SHDR register submode byte bit 5.

2.2.6. CMADR-H (current minute address high) register

Indicates the upper 8 bits of the buffer memory in which the current sector (after completion of correction) minute byte is written. (The lower 10 bits are 00HEX.)

2.2.7. INTSTS (interrupt status) register

The value of each bit in this register indicates that of the corresponding interrupt status. These bits are not affected by the values of the INTMSK register bits.

bit 7: DRVOVRN (drive overrun)

bit 6: DECTOUT (decoder time out)

bit 4: RTADPEND (real-time ADPCM end)

bit 3: HDMACMP (host DMA complete)

bit 2: DECINT (decoder interrupt)

bit 1: BFWRDY (buffer write ready)

bit 0: BFEMPT (buffer empty)

2.2.8. RDDATA (CPU buffer read data)

The buffer data is read out from this register.

2.2.9. ADPCI (ADPCM coding information) register

bit 7: MUTE

This is high when the DA data is muted.

bit 6: EMPHASIS

This is high when emphasis is applied to the ADPCM data.

bit 5: ADPBUSY

This is high for ADPCM decoding.

bit 4: BITLNTH (bit length)

Indicates the bit length of the coding information for ADPCM playback.

High: 8 bits

Low: 4 bits

bit 3: SMADPBSY (sound map ADPCM busy)

This is high during sound map ADPCM playback.

bit 2: FS (sampling frequency)

Indicates the sampling frequency of ADPCM playback.

High: 18.9 kHz

Low: 37.8 kHz

bit 1: RTADPBSY (real-time ADPCM busy)

This is high during real-time ADPCM playback.

bit 0: S/M (stereo/monaural)

Indicates the coding information stereo or monaural for ADPCM playback.

High: stereo

Low: monaural

2.2.10. HXFRC-L (host transfer counter-low)

2.2.11. HXFRC-H (host transfer counter-high)

The HXFRC counter indicates the number of remaining bytes in the data to be transferred between the SCSI controller and the buffer memory. If sound map data is to be transferred before the data is transferred (immediately after the sub CPU has set the BFRD and BFWR bits (bits 7 and 6) of the DMACTL register high), 2304 (900HEX) is loaded into HXFRC. At any other time, the HXFR value is loaded. HXFRC is decremented when data is read from the buffer memory (BFRD is high) or when the IC accepts data from the SCSI controller (BFWR is high).

Therefore, the sub CPU cannot read the HXFRC value during transfer of data between the SCSI controller and the IC. The values of HXDRC and the write register HXFR are almost always different.

2.2.12. HADRC-L (host address counter-low)

2.2.13. HADRC-M (host address counter-middle)

This counter keeps the addresses which write or read the data with the SCSI controller into/from the buffer. If sound map data is to be transferred before the data is transferred, any of 600CHEX, 6A0CHEX or 740CHEX (when connected to 32K-byte buffer memory) is loaded into HADRC. At any other time, the HADR (sub CPU register) value is loaded.

When data from the SCSI controller is written into the buffer or data to the SCSI controller is read from the buffer, the HADRC value is output from MA0 to 16. HADRC is incremented each time one byte of data from the drive is read from the buffer (BFRD is high) or written into the buffer (BFWR is high).

Therefore, the sub CPU cannot read the HADRC value during transfer of data between the SCSI controller and the IC. The values of HADRC and the write register HADR are almost always different.

The upper two bits of HADRC are in HXFRC-H.

2.2.14. DADRC-L

2.2.15. DADRC-M

The DADRC value is incremented before the data from the drive is written into buffer memory. Therefore, the sub CPU can not read the DADRC value during decoder write-only or repeat correction modes.

The upper two DADRC bits are in HXFRC-H.

2.2.16. CADRC-L

2.2.17. CADRC-M

2.2.18. CADRC-H

bit 6: CBFRDRDY (sub CPU buffer read ready)

The sub CPU can read the RDDATA register when this bit is high.

bit 5: CBFWRDY (sub CPU buffer write ready)

The sub CPU can write in the WRDATA register when this bit is high.

bit 2: CADRC17

CADRC bit 17 (MSB).

bit 1: PDATA (pointer data)

The buffer memory pointer bit value can be read from this bit.

bit 0: CADRC16

CADRC bit 16.

REG	ADR	bit7	bit6	bit5	bit4	bit3	bit2	bit1	bit0
DRVIF	00	C2PO L1st	LCH LOW	BCK RED	BCK MD1	BCK MD0	LSB 1st	'L'	'L'
CONFIG 1	01	'L'	XSLOW	'L'	RAM SZ1	RAM SZ0	9bit RAM	CLK DIS	HCLK DIS
CONFIG 2	02	SCYC 1	SCYC 0	SPE CTL	SPMJ CTL	SM BF2	DAMIX DIS	DACOUT EN	PRTY CTL
DECCTL	03	EN DLADR	ECC STR	MODE SEL	FROM SEL	AUTO DIST	DEC MD2	DEC MD1	DEC MD0
DLADR -L	04	bit7	bit6	bit5	bit4	bit3	bit2	bit1	bit0
DLADR -M	05	bit15	bit14	bit13	bit12	bit11	bit10	bit9	bit8
DLADR -H	06	'L'	'L'	'L'	'L'	'L'	'L'	bit17	bit16
CHPCTL	07	SM MUTE	RT MUTE	CDDA MUTE	CD- DA	SW OPEN	RPS TART	DBL SPD	'L'
WRDATA	08	bit7	bit6	bit5	bit4	bit3	bit2	bit1	bit0
INTMSK	09	DRV OVRN	DEC TOUT	'L'	RTADP END	HDMA CMP	DEC INT	BF WRDY	BF EMPT
CLRCTL	0A	CHP RST	'L'	'L'	RTADP CLR	SMADP CLR	'L'	P DATA	RE SYNC
CLRINT	0B	DRV OVRN	DEC TOUT	'L'	RTADP END	HDMA CMP	DEC INT	BF WRDY	BF EMPT
HXFR -L	0C	bit7	bit6	bit5	bit4	bit3	bit2	bit1	bit0
HXFR -H	0D	DIS HXFRC	'L'	HADR bit17	HADR bit16	bit11	bit10	bit9	bit8
HADR -L	0E	bit7	bit6	bit5	bit4	bit3	bit2	bit1	bit0
HADR -M	0F	bit15	bit14	bit13	bit12	bit11	bit10	bit9	bit8
DADRC -L	10	bit7	bit6	bit5	bit4	bit3	bit2	bit1	bit0
DADRC -M	11	bit15	bit14	bit13	bit12	bit11	bit10	bit9	bit8
DADRC -H	12	'L'	'L'	'L'	'L'	'L'	'L'	bit17	bit16
	13 14	'L'	'L'	'L'	'L'	'L'	'L'	'L'	'L'

Sub CPU write registers (1)

REG	ADR	bit7	bit6	bit5	bit4	bit3	bit2	bit1	bit0
CADRC-L	15	bit7	bit6	bit5	bit4	bit3	bit2	bit1	bit0
CADRC-M	16	bit15	bit14	bit13	bit12	bit11	bit10	bit9	bit8
CADRC-H	17	'L'	CPU SRC	CDMA EN	'L'	'L'	'L'	bit17	bit16
DMACTL	18	BFRD	BFWR	SMEN	'L'	'L'	'L'	'L'	'L'
ADPMNT	19	RTADP EN	bit16	bit15	bit14	bit13	bit12	bit11	bit10
SMCI	1A	'L'	EMPH ASIS	'L'	BIT LNGTH	'L'	FS	'L'	S/M
RTCI	1B	'L'	EMPH ASIS	'L'	BIT LNGTH	'L'	FS	ADPMNT bit17	S/M
ATV0	1C	bit7	bit6	bit5	bit4	bit3	bit2	bit1	bit0
ATV1	1D	bit7	bit6	bit5	bit4	bit3	bit2	bit1	bit0
ATV2	1E	bit7	bit6	bit5	bit4	bit3	bit2	bit1	bit0
ATV3	1F	bit7	bit6	bit5	bit4	bit3	bit2	bit1	bit0

Sub CPU write registers (2)

REG	ADR	bit7	bit6	bit5	bit4	bit3	bit2	bit1	bit0
ECCSTS	00	EDC ALL0	ERIN BLK	COR INH	COR DONE	EDC OK	ECC OK	C MODE	C FORM
DECSTS	01	—	—	—	—	—	—	SHRT SCT	NO SYNC
HDRFLG	02	MIN	SEC	BLO CK	MODE	FILE	CHAN NEL	SUB MODE	CI
HDR	03	bit7	bit6	bit5	bit4	bit3	bit2	bit1	bit0
SHDR	04	bit7	bit6	bit5	bit4	bit3	bit2	bit1	bit0
CMADR -H	05	bit17	bit16	bit15	bit14	bit13	bit12	bit11	bit10
INTSTS	07	DRV OVRN	DEC TOUT	—	RTADP END	HDMA CMP	DEC INT	BF WRDY	BF EMPT
RDDATA	08	bit7	bit6	bit5	bit4	bit3	bit2	bit1	bit0
ADPCI	09	MUTE	EMPH ASIS	ADP BSY	BIT LNGTH	SMADP BSY	FS	RTADP BSY	S/M
HXFRC -L	0A	bit7	bit6	bit5	bit4	bit3	bit2	bit1	bit0
HXFRC -H	0B	DC bit17	HC bit17	DC bit16	HC bit16	bit11	bit10	bit9	bit8
HADRC -L	0C	bit7	bit6	bit5	bit4	bit3	bit2	bit1	bit0
HADRC -M	0D	bit15	bit14	bit13	bit12	bit11	bit10	bit9	bit8
DADRC -L	0E	bit7	bit6	bit5	bit4	bit3	bit2	bit1	bit0
DADRC -M	0F	bit15	bit14	bit13	bit12	bit11	bit10	bit9	bit8
	10 1C	—	—	—	—	—	—	—	—
CADRC -L	1D	bit7	bit6	bit5	bit4	bit3	bit2	bit1	bit0
CADRC -M	1E	bit15	bit14	bit13	bit12	bit11	bit10	bit9	bit8
CADRC -H	1F		CBF RDRDY	CBF WRDRY	—	—	bit17	P DATA	bit16

Sub CPU read registers

For HXFRC-H, DC and HC represent DADRC and HASRC respectively.

3. Connection with Buffer Memory

3.1. Memory types

The DRAM pin input, CNFIG1 register RAMSZ1, RAMSZ0 and 9BITRAM bits (bits 4 to 2) are set depending on the buffer memory connected to the IC.

DRAM	RAMSZ1	RAMSZ0	9BITRAM	Memory size
'L'	'L'	'L'	'L'	32K ^w ×8 ^b SRAM
'L'	'L'	'L'	'H'	32K ^w ×9 ^b SRAM
'L'	'L'	'H'	'L'	32K ^w ×8 ^b SRAM×2
'L'	'L'	'H'	'H'	32K ^w ×9 ^b SRAM×2
'L'	'H'	'L'	'L'	128K ^w ×8 ^b SRAM
'L'	'H'	'L'	'H'	128K ^w ×9 ^b SRAM
'L'	'H'	'H'	'L'	128K ^w ×8 ^b SRAM×2
'L'	'H'	'H'	'H'	128K ^w ×9 ^b SRAM×2
'H'	'H'	'H'	'L'	256K ^w ×4 ^b DRAM×2

Figs. 3-1 to 3.5 show examples of connection.

3.2. Access time

The relationship between the decoder clock frequency (MHz) and minimum access time required by the memory (preliminary value, ns) when the CONFIG1 register XSLOW is high is shown below.

Clock frequency	Access time	
	SRAM	DRAM
16.9344	120	110
20.0000	100	90
24.0000	70	80
32.0000	50	50
33.8688	45	50

When XSLOW is low and clock frequency is 16.9344 MHz, SRAM access time is 500 ns and DRAM access time is 300 ns.

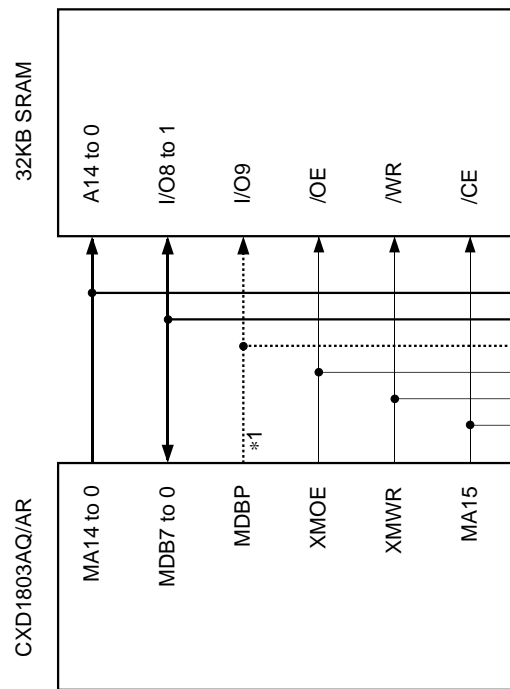

Fig. 3-2 Connection to 64K-byte SRAM

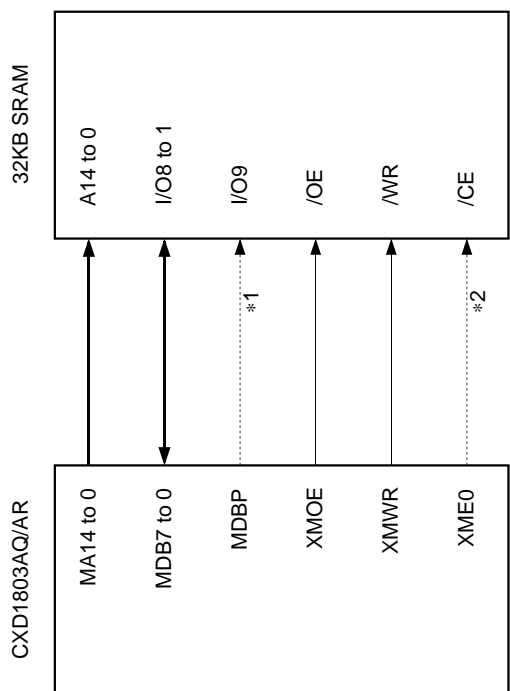

Fig. 3-1 Connection to 32K-byte SRAM

*1 Connect to 9 bits / word SRAM when performing erasure correction.

*2 Connect /CE to XME0 or ground.

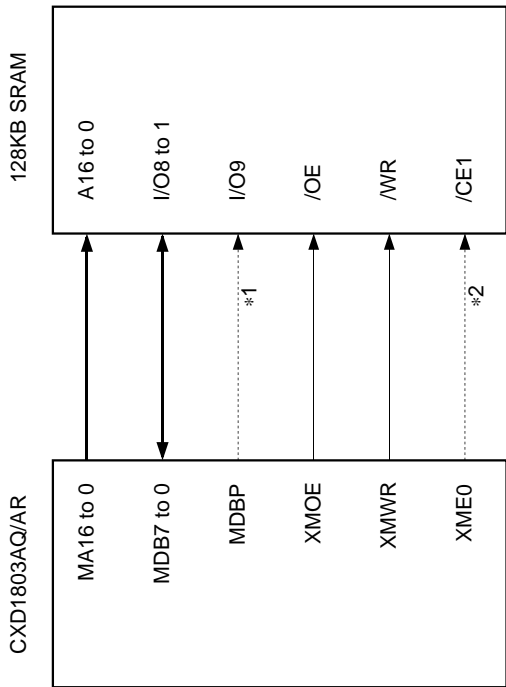

Fig. 3-3 Connection to 128K-byte SRAM

*1 Connect to x9 SRAM when performing erasure correction.

*2 Connect /CE1 to XME0 or ground.

*3 Connect CE2 to VDD.

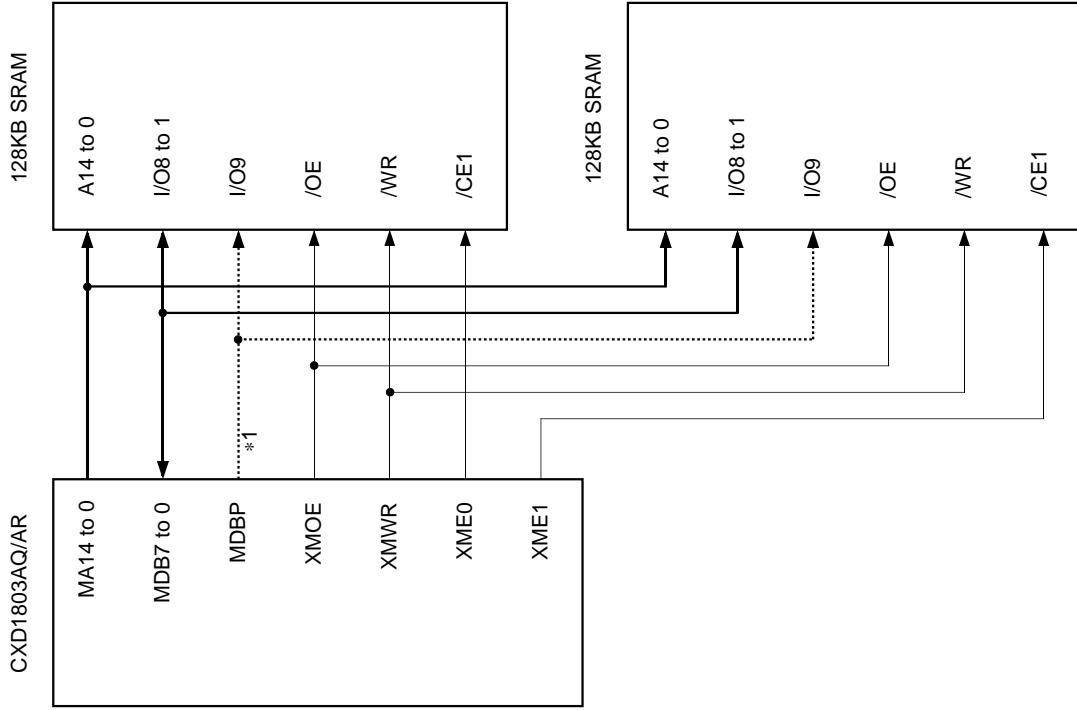

Fig. 3-4 Connection to 256K-byte SRAM

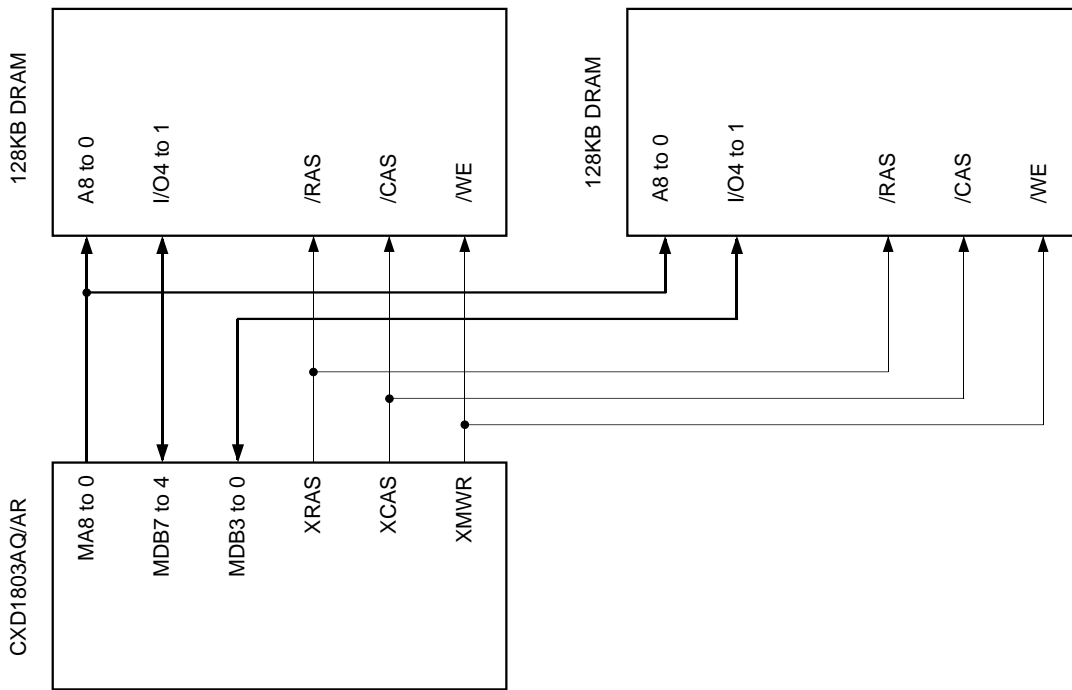

Fig. 3-5 Connection to 256K-byte DRAM

*4 Connect DRAM /OE pin to ground.

This datasheet has been downloaded from:

www.DatasheetCatalog.com

Datasheets for electronic components.



LittleDiode supplies new, hard to find or obsolete electronic components and semiconductors all over the world.

With over two million different components listed you are sure to find the part you need.

Feel free to visit us today at our online store:

LittleDiode.com

Looking forward to providing you with the best possible service.