

CD-ROM DECODER

Description

The CXD1196AR is a CD-ROM decoder LSI with a built-in ADPCM decoder.

Features

- CD-ROM, CD-I and CD-ROM XA format compatible
- Real time error correction
- Double speed playback compatible (when $V_{DD}=5.0\pm 10\%$)
- Can be connected to a standard SRAM up to 32 Kbytes (256 Kbits).
- All audio output sampling frequency : 132.3 kHz (Built-in oversampling filter)
- Built-in de-emphasis digital filter
- Capable of V_{DD} 3.5 V operation

Applications

CD-ROM drive

Structure

Silicon gate CMOS IC

80 pin LQFP (Plastic)

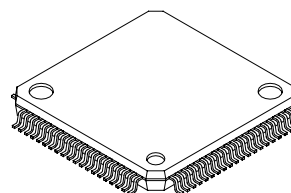
**Absolute Maximum Ratings** ($T_a=25\text{ }^\circ\text{C}$)

• Supply voltage	V_{DD}	$V_{SS}-0.5$ to $+7.0$	V
• Input voltage	V_I	$V_{SS}-0.5$ to $V_{DD}+0.5$	V
• Output voltage	V_O	$V_{SS}-0.5$ to $V_{DD}+0.5$	V
• Operating temperature	T_{opr}	-20 to $+75$	$^\circ\text{C}$
• Storage temperature	T_{stg}	-55 to $+150$	$^\circ\text{C}$

Recommended Operating Conditions

• Supply voltage	V_{DD}	$+3.5$ to $+5.5$ ($+5.0$ Typ.)	V
• Operating temperature	T_{opr}	-20 to $+75$	$^\circ\text{C}$

Sony reserves the right to change products and specifications without prior notice. This information does not convey any license by any implication or otherwise under any patents or other right. Application circuits shown, if any, are typical examples illustrating the operation of the devices. Sony cannot assume responsibility for any problems arising out of the use of these circuits.

Block Diagram

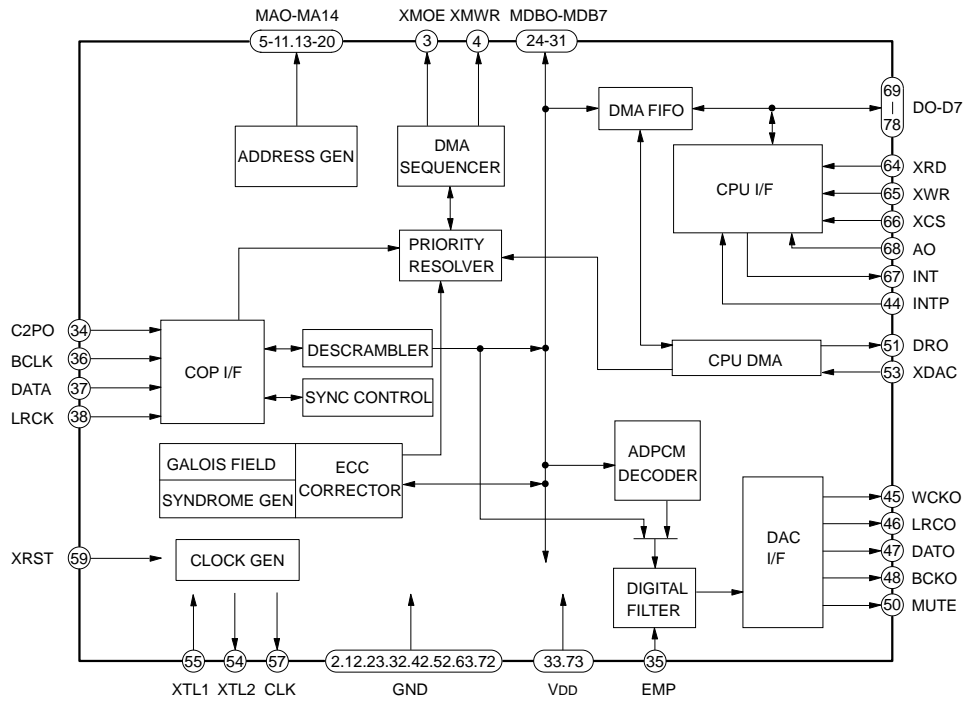

Pin Description

No.	Symbol	I/O	Description
1	TD7	I/O	Test pin
2	GND	—	Ground pin
3	XMOE	O	Buffer memory output enable negative logic signal
4	XMWR	O	Buffer memory write enable negative logic signal
5	MA0	O	Buffer memory address (LSB)
6	MA1	O	Buffer memory address
7	MA2	O	Buffer memory address
8	MA3	O	Buffer memory address
9	MA4	O	Buffer memory address
10	MA5	O	Buffer memory address
11	MA6	O	Buffer memory address
12	GND	—	Ground pin
13	MA7	O	Buffer memory address
14	MA8	O	Buffer memory address
15	MA9	O	Buffer memory address
16	MA10	O	Buffer memory address
17	MA11	O	Buffer memory address
18	MA12	O	Buffer memory address
19	MA13	O	Buffer memory address
20	MA14	O	Buffer memory address (MSB)
21	TD6	I/O	Test pin
22	TD5	I/O	Test pin
23	GND	—	Ground pin
24	MDB0	I/O	Buffer memory data bus (LSB)
25	MDB1	I/O	Buffer memory data bus
26	MDB2	I/O	Buffer memory data bus
27	MDB3	I/O	Buffer memory data bus
28	MDB4	I/O	Buffer memory data bus
29	MDB5	I/O	Buffer memory data bus
30	MDB6	I/O	Buffer memory data bus
31	MDB7	I/O	Buffer memory data bus (MSB)
32	GND	—	Ground pin
33	V _{DD}	—	Power supply pin
34	C2PO	I	C2 pointer positive logic signal from CD player
35	EMP	I	Emphasis positive logic signal from CD player
36	BCLK	I	Bit clock signal from CD player
37	DATA	I	Data signal from CD player
38	LRCK	I	LR clock signal from CD player
39	TD4	I/O	Test pin
40	TD3	I/O	Test pin

No.	Symbol	I/O	Description
41	TD2	I/O	Test pin
42	GND	—	Ground pin
43	TD1	I/O	Test pin
44	INTP	I	INT pin polarity control signal
45	WCKO	O	Word clock signal to DA converter
46	LRCO	O	LR clock signal to DA converter
47	DATO	O	Data signal to DA converter
48	BCKO	O	Bit clock signal to DA converter
49	N. C	—	
50	MUTE	O	Mute positive logic signal
51	DRQ	O	DMA request positive logic signal
52	GND	—	Ground pin
53	XDAC	I	Acknowledge negative logic signal for DRQ
54	XTL2	O	Crystal oscillator circuit output pin
55	XTL1	I	Crystal oscillator circuit input pin
56	TD0	I/O	Test pin
57	CLK	O	Clock with 1/2 frequency of XTL1
58	TDIO	I	Test pin
59	XRST	I	Chip reset negative logic signal
60	TA3	I	Test pin
61	TA2	I	Test pin
62	TA1	I	Test pin
63	GND	—	Ground pin
64	XRD	I	CPU register read strobe negative logic signal
65	XWR	I	CPU register write strobe negative logic signal
66	XCS	I	Chip select negative logic signal from CPU
67	INT	O	Interrupt request signal to CPU
68	A0	I	CPU address signal
69	D7	I	CPU data bus (MSB)
70	D6	I	CPU data bus
71	D5	I	CPU data bus
72	GND	—	Ground pin
73	V _{DD}	—	Power supply pin
74	D4	I	CPU data bus
75	D3	I	CPU data bus
76	D2	I	CPU data bus
77	D1	I	CPU data bus
78	D0	I	CPU data bus (LSB)
79	TA0	I	Test pin
80	N. C	—	

Electrical Characteristics

DC characteristics

(V_{DD}=5 V±10 %, V_{SS}=0 V, Topr=-20 to 75 °C)

Item	Symbol	Conditions	Min.	Typ.	Max.	Unit
TTL input level pin (*1) input voltage H level	V _{IH1}		2.2			V
TTL input level pin (*1) input voltage L level	V _{IL1}				0.8	V
CMOS input level pin (*2) input voltage H level	V _{IH2}		0.7 V _{DD}			V
CMOS input level pin (*2) input voltage L level	V _{IL2}				0.3 V _{DD}	V
TTL schmitt input level pin (*3) input voltage H level	V _{IH3}		2.2			V
TTL schmitt input level pin (*3) input voltage L level	V _{IL3}				0.8	V
TTL schmitt input level pin (*3) input voltage hysteresis	V _{IH3} -V _{IL3}			0.4		V
CMOS schmitt input level pin (*4) input voltage H level	V _{IH4}		0.8 V _{DD}			V
CMOS schmitt input level pin (*4) input voltage L level	V _{IL4}				0.2 V _{DD}	V
CMOS schmitt input level pin (*4) input voltage hysteresis	V _{IH4} -V _{IL4}			0.6		V
Pull-up resistor provided input pin (*5) input current	I _{IL1}	V _{IN} =0 V	-40	-100	-240	μA
Pull-down resistor provided input pin (*6) input current	I _{IL2}	V _{IN} =0 V	40	100	240	μA
Pull-up resistor provided bidirectional pin (*7) input current	I _{IL3}	V _{IN} =0 V	-90	-200	-440	μA
Output voltage H level (*8)	V _{OH1}	V _{OH} =-2 mA	V _{DD} -0.8			V
Output voltage L level (*8)	V _{OL1}	I _{OL} =4 mA			0.4	V
Input leak current (*9)	I _{IL2}		-40		40	μA
Oscillation cell (*10) input voltage H level	V _{IH4}		0.7 V _{DD}			V
Oscillation cell input voltage L level	V _{IL4}				0.3 V _{DD}	V
Oscillation cell logic threshold value	LV _{TH}			0.5 V _{DD}		V
Oscillation cell feedback resistance value	R _{FB}	V _{IN} =V _{SS} or V _{DD}	500 K	1 M	2 M	Ω
Oscillation cell output voltage H level	V _{OH2}	I _{OH} =-3 mA	0.5 V _{DD}			V
Oscillation cell output voltage L level	V _{OL2}	I _{OL} =3 mA			0.5 V _{DD}	V

DC characteristics

(V_{DD}=3.5 V, V_{SS}=0 V, Topr=-20 to 75 °C)

Item	Symbol	Conditions	Min.	Typ.	Max.	Unit
TTL input level pin (*1) input voltage H level	V _{IH1}		2.2			V
TTL input level pin (*1) input voltage L level	V _{IL1}				0.6	V
CMOS input level pin (*2) input voltage H level	V _{IH2}		0.7 V _{DD}			V
CMOS input level pin (*2) input voltage L level	V _{IL2}				0.3 V _{DD}	V
TTL schmitt input level pin (*3) input voltage H level	V _{IH3}		2.2			V
TTL schmitt input level pin (*3) input voltage L level	V _{IL3}				0.6	V
TTL schmitt input level pin (*3) input voltage hysteresis	V _{IH3} -V _{IL3}			0.3		V
CMOS schmitt input level pin (*4) input voltage H level	V _{IH4}		0.8 V _{DD}			V
CMOS schmitt input level pin (*4) input voltage L level	V _{IL4}				0.2 V _{DD}	V
CMOS schmitt input level pin (*4) input voltage hysteresis	V _{IH4} -V _{IL4}			0.5		V
Pull-up resistor provided input pin (*5) input current	I _{IL1}	V _{IN} =0 V	-10	-25	-60	μA
Pull-down resistor provided input pin (*6) input current	I _{IL2}	V _{IN} =0 V	10	25	60	μA
Pull-up resistor provided bidirectional pin (*7) input current	I _{IL3}	V _{IN} =0 V	-20	-50	-110	μA
Output voltage H level (*8)	V _{OH1}	V _{OH} =-1.6 mA	V _{DD} -0.8			V
Output voltage L level (*8)	V _{OL1}	I _{OL} =3.2 mA			0.4	V
Input leak current (*9)	I _{IL2}		-40		40	μA
Oscillation cell (*10) input voltage H level	V _{IH4}		0.7 V _{DD}			V
Oscillation cell input voltage L level	V _{IL4}				0.3 V _{DD}	V
Oscillation cell threshold value	LV _{TH}			0.5 V _{DD}		V
Oscillation cell feedback resistance value	R _{FB}	V _{IN} =V _{SS} or V _{DD}	1.2 K	2.5 M	5 M	Ω
Oscillation cell output voltage H level	V _{OH2}	I _{OH} =-1.3 mA	0.5 V _{DD}			V
Oscillation cell output voltage L level	V _{OL2}	I _{OL} =1.3 mA			0.5 V _{DD}	V

- *1. D7 to 0, MDB7 to 0, TD7 to 0
- *2. DATA, LRCK, C2PO, EMP, INTP, TDIO, TA3 to 0
- *3. XWR, XRD, XCS, A0, XDAC
- *4. BCLK, XRST
- *5. XDAC, TA3 to 0
- *6. C2PO, INTP
- *7. D7 to 0, MDB7 to 0, TD7 to 0
- *8. All output pins except XTL2
- *9. All input pins except *7
- *10. input : XTL1, output : XTL2

Input/Output Capacitance(V_{DD}=V_I=0 V, f=1 MHz)

Item	Symbol	Min.	Typ.	Max.	Unit
Input pin	C _{IN}			9	pF
Output pin	C _{OUT}			11	pF
Input/Output pin	C _{OUT}			11	pF

AC Characteristics

($V_{DD}=5\text{ V}\pm 10\%$, $V_{SS}=0\text{ V}$, $T_{opr}=-20\text{ to }75\text{ }^{\circ}\text{C}$, Output load=50 pF)

The values in parentheses in the table are those obtained when $V_{DD}=3.5\text{ V}$, $V_{SS}=0\text{ V}$, $T_{opr}=-20\text{ to }75\text{ }^{\circ}\text{C}$, and output load=50 pF.

Values without parentheses are common to $V_{DD}=5\text{ V}\pm 10\%$ and 3.5 V.

1. CPU interface

(1) Read

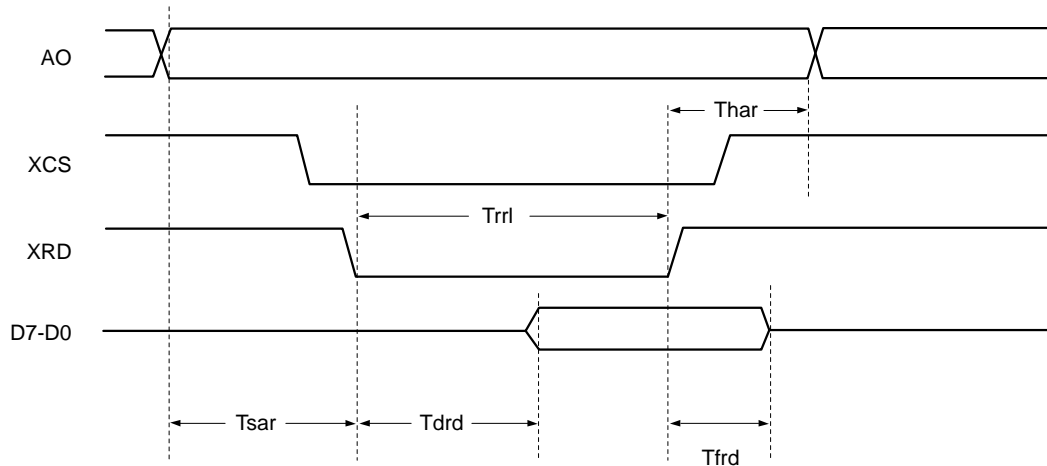

Item	Symbol	Min.	Typ.	Max.	Unit
Address setting time (with respect to XCS & XRD ↓)	Tsar	30 (70)			ns
Address holding time (with respect to XCS & XRD ↑)	Thar	20 (50)			ns
Data delay time (with respect to XCS & XRD ↓)	Tdrd			120 (200)	ns
Data float time (with respect to XCS & XRD ↑)	Tfrd	0		20 (40)	ns
L level XRD pulse width	Trr1	150 (250)			ns

(2) Write

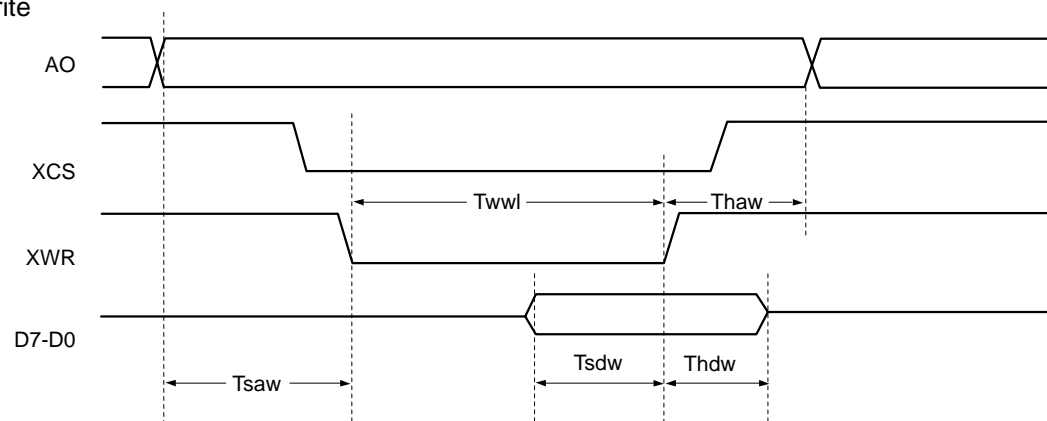

Item	Symbol	Min.	Typ.	Max.	Unit
Address setting time (with respect to XCS & XWR ↓)	Tsaw	30 (70)			ns
Address holding time (with respect to XCS & XWR ↑)	Thaw	20 (50)			ns
Data setting time (with respect to XCS & XWR ↓)	Tsdw	50 (70)			ns
Data holding time (with respect to XCS & XWR ↑)	Thdw	20 (30)			ns
L level XWR pulse width	Tswl	70 (100)			ns

(3) DMA

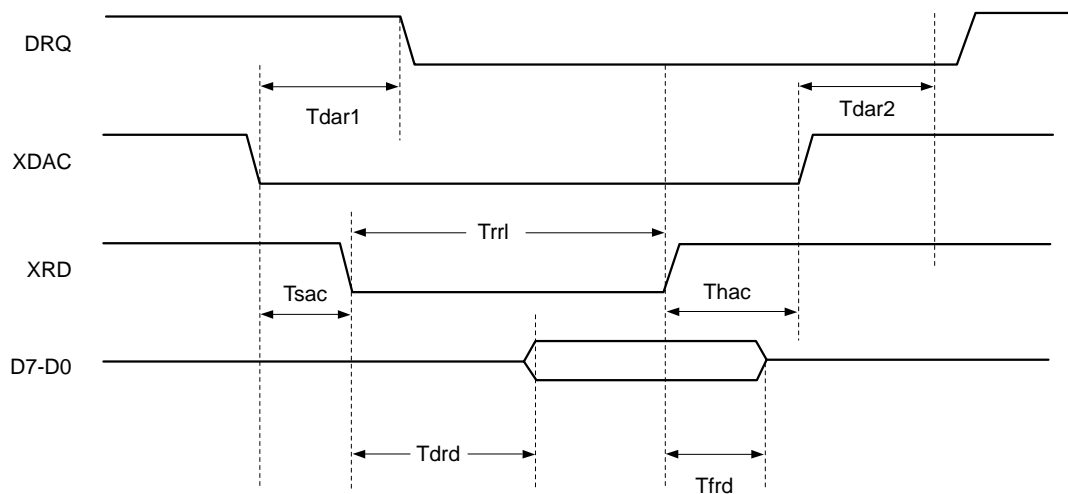

Item	Symbol	Min.	Typ.	Max.	Unit
DRQ fall time (with respect to XDAC ↓)	Tdar1			50 (120)	ns
DRQ rise time (with respect to XDAC ↑)	Tdar2			50 (120)	ns
XDAC setting time (with respect to XRD ↓)	Tsac	10 (30)			ns
XDAC holding time (with respect to XRD ↑)	Thac	10 (30)			ns
Data delay time (with respect to XRD ↓)	Tdrd			120 (200)	ns
Data float time (with respect to XRD ↑)	Tfrd	0		20 (40)	ns
L level XRD pulse width	Trrl	150 (250)			ns

2. SRAM interface

(1) Read

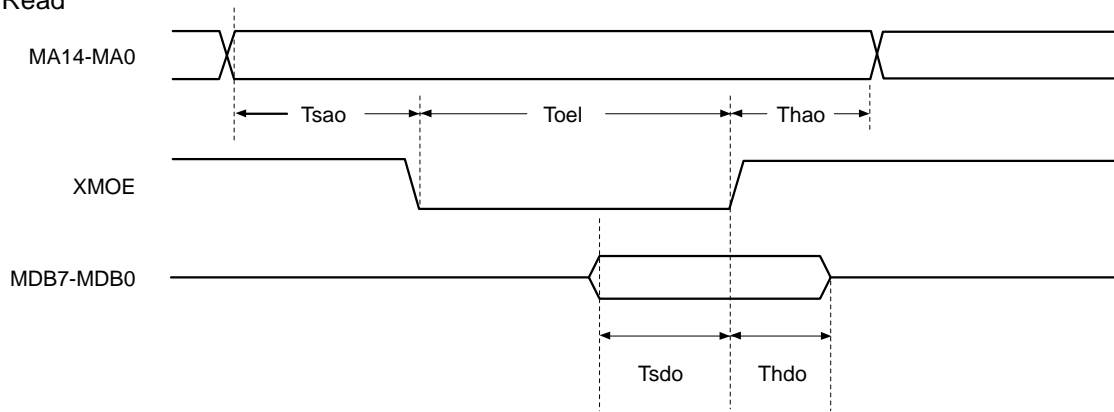

Item	Symbol	Min.	Typ.	Max.	Unit
Address setting time (with respect to XMOE ↓)	Tsao	T ₁ -30			ns
Address holding time (with respect to XMOE ↑)	Thao	T ₁ -10			ns
Data setting time (with respect to XMOE ↑)	Tsd0	50 (100)			ns
Data holding time (with respect to XMOE ↑)	Thdo	10 (20)			ns
L level XMOE pulse width	Toel		2 • T ₁		ns

(2) Write

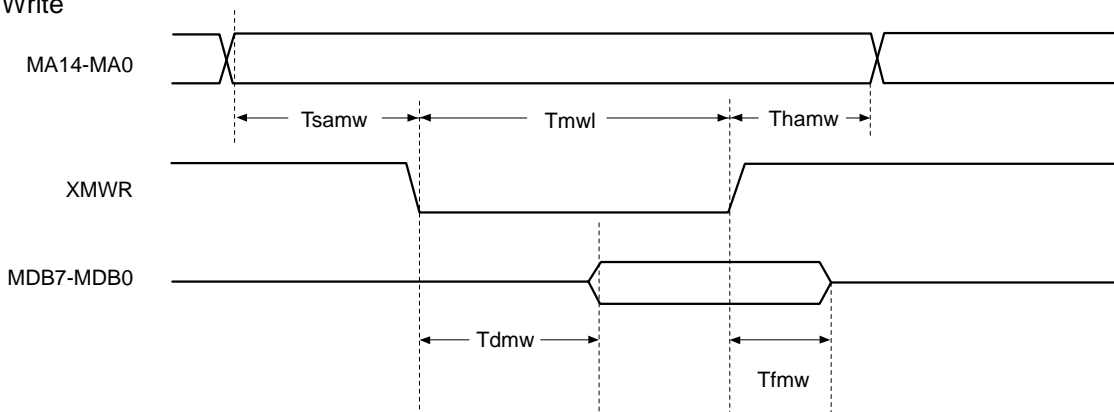

Item	Symbol	Min.	Typ.	Max.	Unit
Address setting time (with respect to XMWR ↓)	Tsamw	T ₁ -30			ns
Address holding time (with respect to XMWR ↑)	Thamw	T ₁ -10			ns
Data delay time (with respect to XMWR ↓)	Tdmw			0	ns
Data float time (with respect to XMWR ↑)	Tfmw	10			ns
L level XMWR pulse width	Tmwl		2 • T ₁		ns

$$T_1 = \begin{cases} 59 \text{ ns} : & \text{XSLOW} = \text{'H'} \\ 238 \text{ ns} : & \text{XSLOW} = \text{'L'} \end{cases}$$

Note that XSLOW is bit 7 of DRVIF register.

When XSLOW = 'H', make sure that the CXD1196AR is connected to an SRAM with an access time of less than 120 ns.

When XSLOW = 'L', make sure that the CXD1196AR is connected to an SRAM with an access time of less than 320 ns.

3. DSP Interface for CD

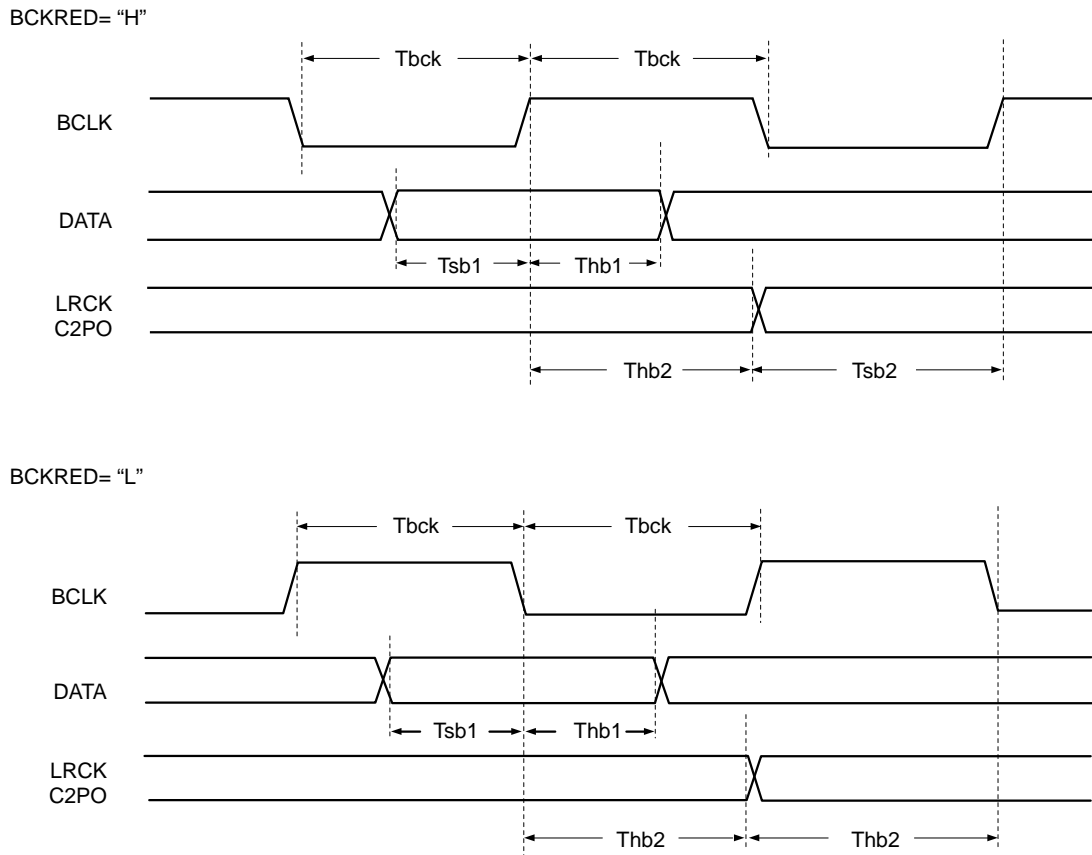

Item	Symbol	Min.	Typ.	Max.	Unit
BCLK frequency	Fbck			5.7	MHz
BCLK pulse width	Tbck	85			ns
Data setting time (with respect to BCLK)	Tsb1	50			ns
Data holding time (with respect to BCLK)	Thb1	50			ns
LRCK, C2PO setting time (with respect to BCLK)	Tsb2	50			ns
LRCK, C2PO holding time (with respect to BCLK)	Thb2	50			ns

4. DAC interface

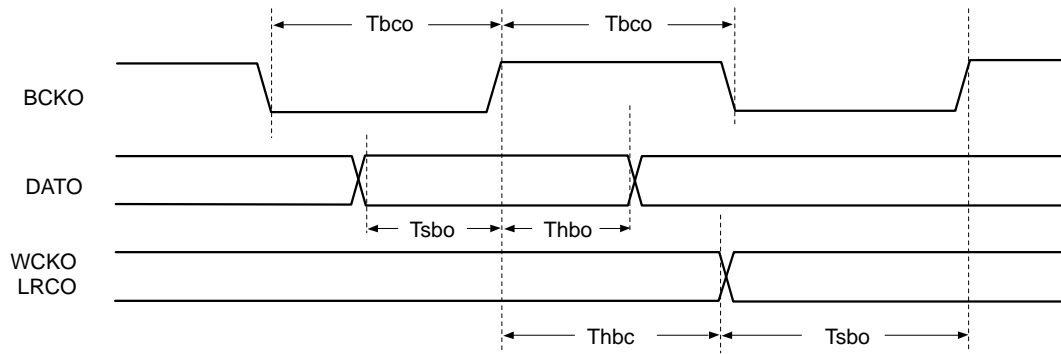

Item	Symbol	Min.	Typ.	Max.	Unit
BCKO frequency	Fbco		8.4672		MHz
BCKO pulse width	Tbco	50			ns
DATO, WCKO, LRCO setting time (with respect to BCKO ↑)	Tsbo	30			ns
DATO, WCKO, LRCO holding time (with respect to BCKO ↑)	Thbo	30			ns

5. XTL1 pin, XTL2 pins

(1) Self-excited oscillation

Item	Symbol	Min.	Typ.	Max.	Unit
Oscillation frequency	Fmax		16.9344		MHz

(2) When pulses are to be input to XTL1 pin

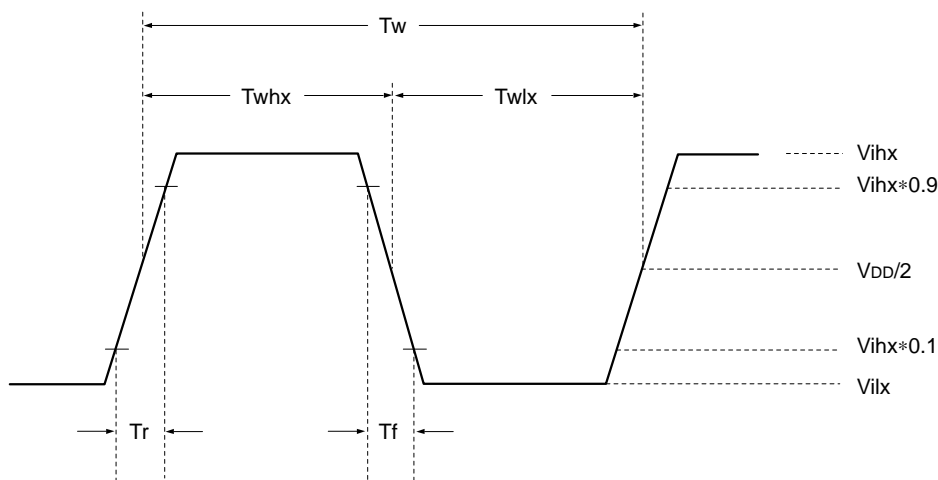

Item	Symbol	Min.	Typ.	Max.	Unit
H level pulse width	Twhx	20			ns
L level pulse width	Twlx	20			ns
Pulse interval	Tw		59		ns
Input H level	Vihx	$V_{DD}-1.0$			V
Input L level	Vilx			0.8	V
Rise time	Tr			15	ns
Fall time	Tf			15	ns

Note) Synchronize XTL1 clock with DSP clock for CD.
 (Use the clock generated from the same oscillator unit.)

Description of Functions

1. Description of Pins

1.1 CD player interface

The CXD1196AR can be directly connected to digital signal processing LSIs for CD of Sony and other company. The digital signal processing LSI for CD is referred to as a DSP for CD.

- (1) DATA (DATA : Input)
Serial data stream from a CIRC LSI
- (2) BCLK (Bit Clock : Input)
Bit clock signal for strobing DATA signal
- (3) LRCK (LR Clock : Input)
LR clock signal indicating Lch and Rch of DATA signal
- (4) C2PO (C2 Pointer : Input)
C2 pointer signal indicating that DATA input contains an error
- (5) EMP (Emphasis : Input)
Emphasis indicating that the data from the DSP is emphasized. (positive logic signal)

1.2 Buffer memory interface

The CXD1196AR can be connected to a standard SRAM up to 32 Kbytes (256 Kbits).

- (1) XMWR (BUFFER MEMORY WRITE : OUT)
Data write signal to buffer memory (strobe negative logic output)
- (2) XMOE (BUFFER MEMORY OUTPUT ENABLE : OUT)
Data read signal to buffer memory (strobe negative logic output)
- (3) MA0-14 (BUFFER MEMORY ADDRESS : OUT)
Address signals to buffer memory
- (4) MDB0-7 (BUFFER MEMORY DATA BUS : BUS)
Buffer memory data bus signal pulled up by a typical 25 k Ω resistor

In an ADPCM decode playback drive, make sure that the CXD1196AR is connected to a 256 Kbit (8^b × 32 K^w, 32 Kbyte) SRAM

1.3 CPU interface

- (1) XWR (CPU WRITE : Input)
Strobe signal for writing to register in chip (negative logic input)
- (2) XRD (CPU READ : Input)
Strobe for reading out status of register chip (negative logic input signal)
- (3) D0-7 (CPU DATA BUS : Input and output)
8-bit data bus
- (4) A0 (CPU ADDRESS : Input)
CPU address signal for selecting internal register of the CXD1196AR
- (5) INT (CPU INTERRUPT : Output)
Interrupt request output signal for CPU. The polarity of this signal can be controlled by the INTP pin.
- (6) INTP (INTERRUPT POLARITY : Input)
This pin controls the polarity of the INT pin. In the IC, it is pulled up by a typical 50 k Ω register.
When INTP= 'H' or open, the INT pin goes low active.
When INTP= 'L', the INT pin goes high active.
- (7) XCS (CHIP SELECT : Input)
Chip select signal for CPU to select the CXD1196AR (negative logic input)

- (8) DRQ (DATA REQUEST : Output)
DMA data request signal (positive logic output)
- (9) XDAC (DATA ACKNOWLEDGE : Input)
The acknowledge signal for DRQ (negative logic input). In the IC, it is pulled up by a typical 50 k Ω resistor.

1.4 DAC interface

- (1) BCKO (BIT CLOCK OUTPUT : Output)
Bit clock output signal to DA converter
- (2) WCKO (WORD CLOCK OUTPUT : Output)
Word clock output signal to DA converter
- (3) LRCO (LR CLOCK OUTPUT : Output)
LR clock output signal to DA converter
- (4) DATO (DATA OUTPUT : Output)
Data output signal to DA converter

Fig. 1.1 shows a timing chart for interface with the DA converter.

1.5 Miscellaneous

- (1) MUTE (MUTE : Output)
Output H when DA data is muted
- (2) XRST (RESET : Input)
Chip reset signal (negative logic input)
- (3) XTL1 (X'TAI1 : Input)
- (4) XTL2 (X'TAI2 : Output)
Connect a 16.9344 MHz crystal oscillator unit between XTL1 and XTL2. (The value of the capacitor depends on the crystal oscillator unit.) Or input 16.9344 MHz clock to the XTL1 pin. For ADPCM or CD-DA playback, the clocks of the DSP for CD and this IC must be synchronized.
- (5) CLK (CLOCK : Output)
Output 8.4672 clock.
When this clock is not be used, the output of the CLK pin may be fixed at 'L'.

1.6 Test pins

These pins are normally kept in the opened state.

- (1) TD0-7 (Input/Output) : Data bus for IC test. Pulled up by a typical 25 k Ω resistor.
- (2) TDIO (Input) : Input pin for IC test. Pulled up by a typical 50 k Ω resistor.
- (3) TA0-3 (Input) : Input pins for IC test. Pulled up by a typical 50 k Ω resistor.

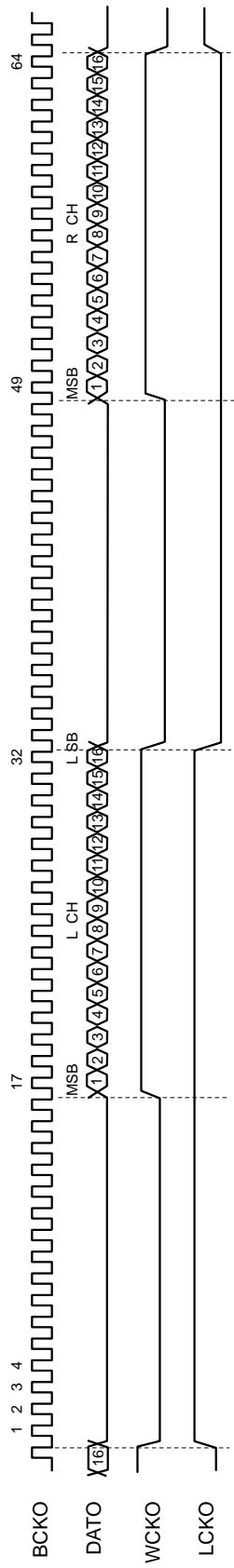

Fig. 1.1 Output Format to DA Converter

2. Register Functions

2.1 Write register

2.1.1 Register address (REGADR) register

This register is used for selection of the internal registers.

- (1) When A0 = XCS = 'L', the REGADR register is selected. When A0 = 'H' and XCS = 'L', the register specified by the REGADR is selected.
- (2) When the low order 4 bits of REGADR are not 0 (hex), and a register write or read is made by setting A0 = 'H' and XCS = 'L', the low order 4 bits of REGADR are incremented.
- (3) REGADR is cleared by rising edge of DMAEN bit (bit3) of the DMACTL register. (Cleared to 00 (hex).)

2.1.2 DRIVE Interface (DRVIF) register

Bit7 XSLOW (/SLOW SPEED)

'H' : A DMA cycle is performed in 4 clocks.

In this case, a standard SRAM with an access time of less than 120 nsec can be connected to the CXD1196AR.

'L' : A DMA cycle is performed in 12 clocks. When the CXD1196R is connected to an SRAM with a slower access time, set this bit at 'L'. In this case, a standard SRAM with an access time of less than 320 ns can be connected to the CXD1196AR. For operation at V_{DD} = 3.5 V, set this bit to L.

Bit6 C2PL1ST (C2PO Ler-byte 1st)

'H' : To input two bytes of DATA input, each with a C2PO identifying the lower or upper byte, in the order of the lower and upper bytes

'L' : To input two bytes of DATA input, each with a C2PO identifying the upper or lower byte, in the order of the upper and lower bytes.

Here, the upper byte means the 8 (eight) upper bits including the MSB from the DSP for CD. And the lower byte means the 8 (eight) lower bits including the LSB from the DSP for CD. For example, the minute byte of the Header is a lower byte and the sec byte is a upper byte.

Bit5 LCHLOW (LCH LOW)

'H' : To determine that the data is Lch data when LRCK = 'L'

'L' : To determine that the data is Lch data when LRCK = 'H'

Bit4 BCKRED (BCLK Rising Edge)

'H' : To strobe DATA by the rising edge of BCLK

'L' : To strobe DATA by the falling edge of BCLK

Bit3, 2 BCKMD1, 0 (BCLK Mode 1, 0)

Set these bits, depending on the number of BCLK clocks output by the DSP for CD during a cycle of WCLK.

BCKMD1	BCKMD0	
'L'	'L'	16BCLKs/WCLK
'L'	'H'	24BCLKs/WCLK
'H'	'X'	32BCLKs/WCLK

Bit1 LSB 1ST (LSB First)

'H' : To connect to a DSP for CD which outputs DATA on an LSB first basis

'L' : To connect to a DSP for CD which outputs DATA on an MSB first basis

Bit0 CLKLOW (CLK LOW)

'H' : To fix CLK pin output at 'L'

'L' : To output 8.4672 MHz clock from CLK pin output

The values of the individual bits of this register must be changed with the decoder in the disabled state. Table 2.1.1 shows the values of bits of bit 6 through 1 to be set when the CXD1196AR is connected to Sony DSPs for CD. Fig. 2.2.1 (1) through (3) show input timing charts.

Sony DSP for CD	DRVIF register						Timing chart
	bit6	bit5	bit4	bit3	bit2	bit1	
CDL30 series CDL35 series	L	L	L	L	H	L	Fig. 2.1.1 (1)
CDL40 series (48-bit slot mode)	L	L	H	L	H	L	Fig. 2.1.1 (2)
CDL40 series (64-bit slot mode)	L	H	L	H	X	H	Fig. 2.1.1 (3)

Table 2.1.1 DRVIF Register Settings

(Note 1)

CDL30 series	CXD1125Q/QZ, CXD1130Q/QZ, CXD1135Q/QZ, CXD1241Q/QZ, CXD1245Q, CXD1246Q/QZ, CXD1247Q/QZ/R, etc.
CDL35 series	CXD1165Q, CXD1167Q/QZ/R, etc.
CDL40 series	CXD2500Q/QZ, etc.

2.1.3 Chip Control (CHPCTL) register

Bit7-5 RESERVED

Bit4 CHPRST (Chip Reset)

When this bit is set at 'H', the CXD1196AR is internally initialized. The bit setting will automatically change to 'L' when the internal initialization of the CXD1196AR is completed. Therefore, there is no need for the CPU to change the setting at 'L'. Initialization of the CXD1196AR will be completed in 500ns after the bit has been set at 'H' by the CPU.

Bit3 CD-DA (CD-Digital Audio)

'H' : When a CD-DA disc is to be played back, this bit is set at 'H'.

The decoder must be placed in the disabled state (DECCTL register) when this bit is set at 'H'.

'L' : When a CD-ROM disc is to be played back, this bit is set at 'L'.

Bit2 SWOPN (Sync Window Open)

'H' : When this bit is set at 'H', the window for detection of SYNC mark will open. In this case, the SYNC protection circuit in the CXD1196AR will be disabled.

'L' : When this bit is set at 'L', the window for detection of SYNC mark will be controlled by the SYNC protection circuit in the CXD1196AR.

Bit1 RPSTART (Repeat Correction Start)

When the DECODER is placed in the repeat correction mode, and this bit set at 'H', the error correction of the current sector will begin. The bit setting will automatically change to 'L' when correction begins. Therefore, there is no need for the CPU to change the setting at 'L'.

Bit0 ADPEN (ADPCM Enable)

When the current sector is an ADPCM sector, the CPU sets this bit at 'H' in less than 11.5 ms after a decoder interrupt (DECINT). When the current sector is not an ADPCM sector, the CPU changes the bit setting at 'L' in less than 11.5 ms after a decoder interrupt (DECINT).

2.1.4 DECODER CONTROL (DECCTL) Register

Bit7 AUTO CI (Auto Coding Information)

'H' : To perform ADPCM playback according to the coding information from the drive. In this case, the CI register need not be set.

'L' : To perform ADPCM playback according to the value of the CI register.

Bit6 RESERVED

Should be kept at 'L' at all times.

Bit5 MODESEL (Mode Select)

Bit4 FORMSEL (Form Select)

When AUTODIST = 'L', the sector is corrected as the following MODE and FORM.

MODESEL	FORMSEL	
'L'	'L'	MODE1
'H'	'L'	MODE2, FORM1
'H'	'H'	MODE2, FORM2

Bit3 AUTODIST (Auto Distinction)

'H' : Errors are corrected according to the MODE byte and FORM bit read from the drive.

'L' : Errors are corrected according to bit 5 MODESEL and bit4 FORMSEL.

Bit2-0 : DECMD 2-0 (Decoder Mode 2-0)

DECMD2	DECMD1	DECMD0	
'L'	'L'	'X'	Decoder disable
'L'	'H'	'X'	Monitor only mode
'H'	'L'	'L'	Write only mode
'H'	'L'	'H'	Real time correction mode
'H'	'H'	'L'	Repeat correction mode
'H'	'H'	'H'	Inhibit

These bits are set at 'L' when the CDDA bit (bit3) of the CHPCTL register is 'H'.

2.1.5 Interrupt Mask (INTMSK) Register

When the individual bits of this register are set at 'H', an interrupt request from the CXD1196AR to the CPU is enabled in response to the corresponding interrupt status. (That is, when the interrupt status is created, the INT pin is made active.) The value of the individual bits of the register does not affect the corresponding interrupt status.

Bit7 ADPEND (ADPCM End)

When this chip has completed the ADPCM decode for a sector, if the ADPCM decode for the next sector is not enabled, the ADPEND status is created.

Bit6 DECTOUT (Decoder Time Out)

If no SYNC mark is detected during a period of 3 sectors (40.6 ms in normal speed playback mode) after the DECODER has been set in the monitor only, and real time correction modes, the DECTOUT status is created.

Bit5 DMACMP (DMA Complete)

When DMA is ended by DMAXFRC, the DMACMP status is created.

Bit4 DECINT (Decoder Interrupt)

If a SYNC mark is detected or internally inserted during execution of the write only, monitor only and real time correction modes by the DECODER, the DECINT status is created. When the SYNC mark detected window is open, however, if the SYNC mark spacing is less than 2352 bytes, the DECINT status is not created. During execution of the repeat correction mode by the DECODER, the DECINT status is created each time a correction ends.

Bit3 CIERR (Coding Information Error)

When AUTOCl bit of DECCTL register is set at "H" and ADPCM decode playback is done, if there is an error in a CI byte of an ADPCM sector, the CIERR status is created. ADPCM decode playback of this sector will not be done.

Bit2-0 RESERVED

2.1.6 Clear Interrupt Status (INCTCLR) Register

When the individual bit of this register is set at 'H', the corresponding interrupt status is cleared. The individual bit is automatically set at 'L' after the interrupt status has been cleared. Therefore, there is no need for the CPU to change the setting at 'L'.

Bit7 ADPEND (ADPCM End)

Bit6 DECTOUT (DECODER Time Out)

Bit5 DMACMP (DMA Complete)

Bit4 DECINT (DECODER Interrupt)

Bit3 CIERR (Coding Information Error)

Bit2-0 RESERVED

2.1.7 Coding Information (CI) Register

When ADPCM decoding is to be done by setting AUTOCl = 'L', the coding information is written to this register. The bit configuration is the same as that of the coding information byte of the sub header.

2.1.8 DMA Address Counter-L (DMAADRC-L)**2.1.9 DMA Address Counter-H (DMAADRC-H)**

This counter retains the address to be used by the CPU when reading data from the buffer. When the data to be sent to the CPU is read from the buffer, the contents of the DMAADRC are output from MA0-14. Each time data to be sent to the CPU is read from the buffer, the DMAADRC is incremented.

The CPU sets the head address of DMA in the DMAADRC before starting DMA. The CPU can read and set the contents of the DMAADRC at any time. Do not change the contents of the DMAADRC during execution of DMA.

2.1.10 DMAXFRC-L

2.1.11 DMA Control (DMACTL) register

- Bit7 DMAXFRC11
Bit11 (MSB) of DMAXFRC (Transfer Counter)
- Bit6 DMAXFRC10
bit10 of DMAXFRC
- Bit5 DMAXFRC9
bit9 of DMAXFRC
- Bit4 DMAXFRC8
bit8 of DMAXFRC
- Bit3 DMAEN (CPU DMA Enable)
'H' : To enable DMA
'L' : To inhibit DMA
- Bit2-0 RESERVED

The DMAXFRC (DMA Transfer Counter) is a counter which indicates the number of DMA transfers. Each time the data to be transferred to the CPU is read from the buffer, the counter is decremented. When the value of the DMAXFRC reaches 0, DMA ends. At this point, interrupt request may be output to the CPU. When data transfer is not to be ended by DMAXFRC as in the case of data transfer in the I/O mode, DMAXFRC should be set at 0 when data transfer is started (when DMAEN bit is set at 'H'). The CPU can read and set the contents of DMAXFRC at any time. During execution of DMA, do not change the contents of DMAXFRC.

2.1.12 DRVADRC-L (Drive Address Counter-L)

2.1.13 DRVADRC-H

The DRVADRC is a counter which retains the address for writing the data from the drive to the buffer. When the drive data is written to the buffer, the value of DRVADRC is output from MA01-14 pins. Each time a byte of data from the drive is written to the buffer, the DRVADRC is incremented. Before execution of the write only mode and real time correction mode of the DECODER, the CPU sets the buffer write head address in the DRVADRC. The CPU can read and set the contents of DRVADRC at any time. During execution of DMA, do not change the contents of DRVADRC.

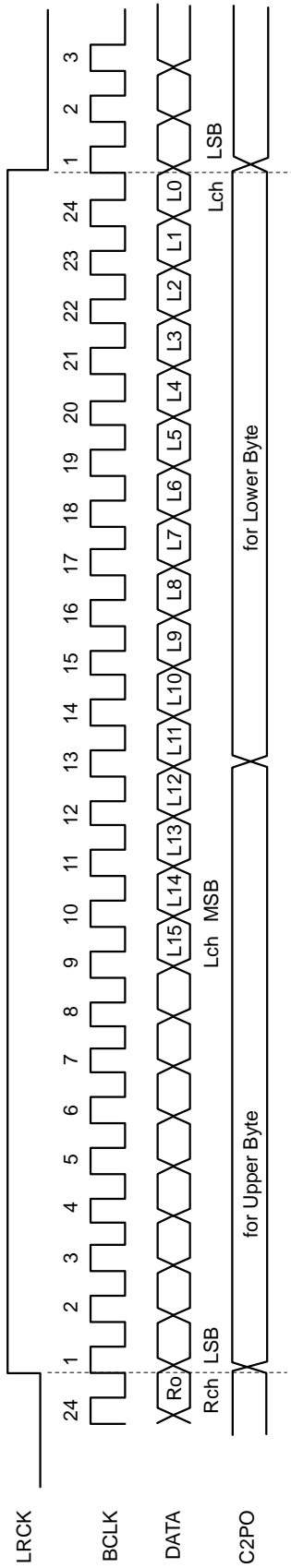

Fig. 2.1.1 (1) CDL30 and 35 Series Timing Chart

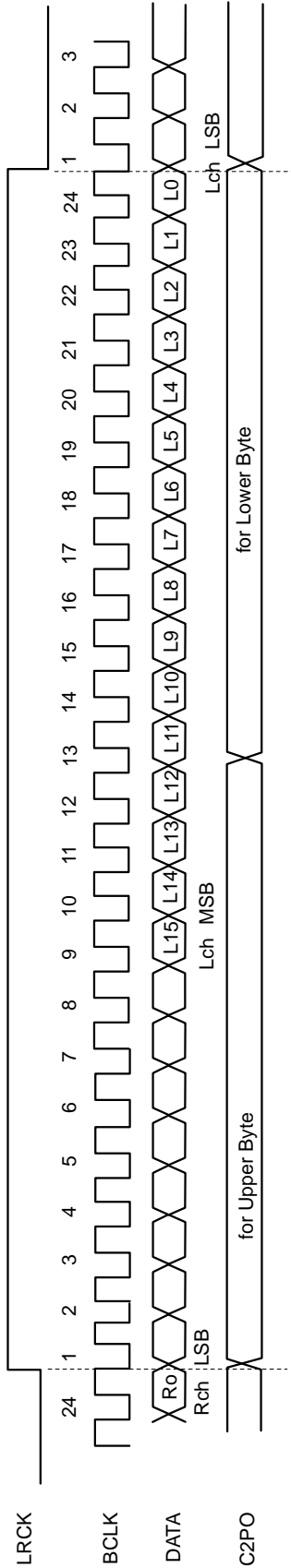

Fig. 2.1.1 (2) CDL40 Series 48-Bit Slot Mode Timing Chart

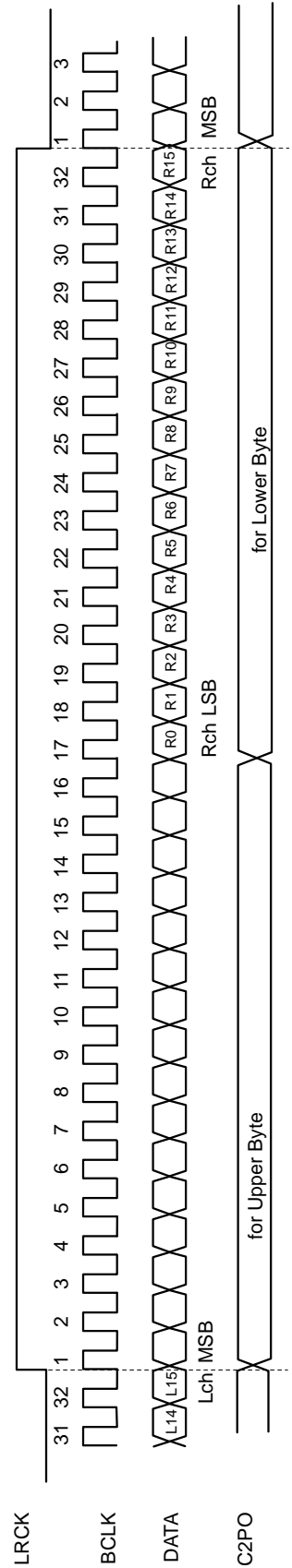

Fig. 2.1.1 (3) CDL40 Series 64-Bit Slot Mode Timing Chart

2.2 Read register

In the descriptions of the registers STS, HDRFLG, HDR, SHDR and CMADR, what is referred to as the current sector refers to the sector where registers are valid for a decoder interrupt (DECINT). In the monitor only and write only modes, the sector from the DSP for CD just before a decoder interrupt is called the current sector. In the real time correction mode and repeat correction mode, the sector that has gone through error detection and correction is referred to as the current sector.

2.2.1 Register Address (REGADR) Register

2.2.2 DMADATA Register

When data transfer (buffer read) is to be made in the I/O mode, the CPU reads data from this register.

2.2.3 Interrupt Status (INTSTS) Register

The values of the individual bits of this register indicate the respective associated values of interrupt status. These bits are not affected by the values of the individual bits of the INTMSK register.

- Bit7 ADPEND (ADPCM End)
- Bit6 DECTOUT (DECODER Time Out)
- Bit5 DMACMP (DMA Complete)
- Bit4 DECINT (DECODER Interrupt)
- Bit3 CIERR (Coding Information Error)

2.2.4 Status (STS) Register

- Bit7 DRQ (Data Request)
This bit indicates the value of the DRQ pin.
- Bit6 ADPBSY (ADPCM BUSY)
This bit goes 'H' during ADPCM playback.
- Bit5 ERINBLK (Erasure in Block)
On all the bytes of the current sector except the SYNC byte, this bit goes 'H' if there is one or more bytes from the DSP for CD whose C2 pointer is ON.
- Bit4 CORINH (Correction Inhibit)
When the DECCTL register is set AUTODIST bit = 'H', this bit goes 'H' if the error flag is ON in the MODE (and FORM) byte.
- Bit3 EDCOK
Indicates EDC check showed there were no errors in the current sector.
- Bit2 ECCOK
Indicates there are no more errors from the Header to P parity bytes in the current sector. (In the MODE2, FORM2 sector, this bit is treated as a DON'T CARE bit.)
- Bit1 SHRTSCT (Short Sector)
Indicates the Sync Mark interval was less than 2351 bytes. On this sector, neither ECC nor EDC is executed.
- Bit0 NOSYNC
Indicates that the SYNC Mark, not detected in the predetermined position, is one internally inserted.

2.2.5 Header Flag (HDRFLG) Register

Indicates the value of the error pointer of the Header and Sub Header registers.

2.2.6 Header (HDR) Register

It is a 4-byte register indicating the Header byte of the current sector. The CPU can find the value of the Header byte of the current sector from the Minute byte as it sets the REGADR register at X4 hex and successively reads data.

2.2.7 Sub Header (SHDR) Register

It is a 4-byte register indicating the Sub Header byte of the current sector. The CPU can find the value of the Sub Header byte of the current sector from the File byte as it sets the REGADR register at 08 hex and successively reads data.

2.2.8 Current Minute Address L (CMADR-L) Register

2.2.9 Current Minute Address H (CMADR-H) Register

Indicates the buffer memory address where the Minute bytes of the current sector (after correction) is in store.

2.2.10 MODE/FORM (MDFM) Register

Bit4-2 RMODE2-0

RMODE2 : Indicates the logic sum of the value of the high-order 6 bits of the raw MODE byte and the pointer.

RMODE1, 0 : Respectively indicate the values of the low-order 2 bits of the raw MODE byte.

Bit1 CMODE (Correction Mode)

Bit0 CFORM (Correction Form)

These bits indicate which of the MODEs and FORMs this IC determined that the current sector was associated with when it corrected errors.

CFORM	CMODE	
'X'	'L'	MODE1
'L'	'H'	MODE2, FORM1
'H'	'H'	MODE2, FORM2

2.2.11 ADPCI (ADPCM Coding Information) Register

Bit7 MUTE

This bit goes 'H' when the DA data is muted on.

Bit6 EMPHASIS

This bit goes 'H' when the ADPCM data is emphasized.

Bit5 EOR (End of Record)

This bit goes 'H' when the Sub Mode byte bit0 = 'H' and there is no error in the Sub Mode byte.

Bit4 BITLENGTH (Bit Length)

This bit indicates the bit length of ADPCM playback coding information.

'H' : 8 bits

'L' : 4 bits

Bit2 FS (Sampling Frequency)

This bit indicates the ADPCM playback sampling frequency.

'H' : 18.9 kHz

'L' : 37.8 kHz

Bit0 M/S (MONO/STEREO)

This bit indicates "monaural" or "stereo" of ADPCM playback coding information.

'H' : Stereo

'L' : Monaural

2.2.12 DMAXFRC-L

2.2.13 DMAXFRC-H

2.2.14 DMAADRC-H

2.2.15 DMAADRC-H

2.2.16 DRVADRC-L

2.2.17 DRVADRC-H

REG	A0	RA	bit7	bit6	bit5	bit4	bit3	bit2	bit1	bit0
REGADR	L	X	L	L	L	RA4	RA3	RA2	RA1	RA0
RESERVED	H	X0	L	L	L	L	L	L	L	L
DRVIF	H	X1	XSLOW	C2POL1st	LCHLOW	BCKRED	BCKMD1	BCKMD0	LSB1st	CLKL
CHPCTL	H	X2	L	L	CLRADP	CHPRST	CD-DA	SWOPEN	RPS TART	ADPEN
DECCTL	H	X3	AUTO CI	L	MODE SEL	FORM SEL	AUTO DIST	DEC MD2	DEC MD1	DEC MD0
INTMSK	H	X4	ADPEND	DECTOUT	DMA CMP	DEC INT	CI ERR	L	L	L
INTCLR	H	X5	ADPEND	DECTOUT	DMA CMP	DEC INT	CI ERR	L	L	L
CI	H	X6	L	EMPHASIS	L	BIT L4H8	L	FS L3H1	L	MONOSTE
DMA ADRC-L	H	X7	bit7	bit6	bit5	bit4	bit3	bit2	bit1	bit0
DMA ADRC-H	H	X8	L	bit14	bit13	bit12	bit11	bit10	bit9	bit8
DMA XFRC-L	H	X9	bit7	bit6	bit5	bit4	bit3	bit2	bit1	bit0
DMACTL	H	XA	xfrcl1	xfrcl0	xfrcl9	xfrcl8	DMA EN	L	L	L
DRV ADRC-L	H	XB	bit7	bit6	bit5	bit4	bit3	bit2	bit1	bit0
DRV ADRC-H	H	XC	L	bit14	bit13	bit12	bit11	bit10	bit9	bit8
TEST2	H	1D	L	L	L	L	L	L	L	L
TEST1	H	1E	L	L	L	L	L	L	L	L
TEST0	H	1F	L	L	L	L	L	L	L	L

Write Registers

REG	A0	RA	bit7	bit6	bit5	bit4	bit3	bit2	bit1	bit0
REGADR	L	X	X	X	X	RA4	RA3	RA2	RA1	RA0
DMA DATA	H	00	bit7	bit6	bit5	bit4	bit3	bit2	bit1	bit0
INTSTS	H	01	ADP END	DEC TOUT	DMA CMP	DEC INT	CI ERR	X	X	X
STS	H	02	DRQ	ADP BSY	ERIN BLK	COR INH	EDC OK	ECC OK	SHRT SCT	NO SYNC
HDRFLG	H	03	MIN	SEC	BLO CK	MODE	FILE	CHAN NEL	SUB MODE	CI
HDR MIN	H	X4	bit7	bit6	bit5	bit4	bit3	bit2	bit1	bit0
HDR SEC	H	X5	bit7	bit6	bit5	bit4	bit3	bit2	bit1	bit0
HDR BLOCK	H	X6	bit7	bit6	bit5	bit4	bit3	bit2	bit1	bit0
HDR MODE	H	X7	bit7	bit6	bit5	bit4	bit3	bit2	bit1	bit0
SHDR FILE	H	08	bit7	bit6	bit5	bit4	bit3	bit2	bit1	bit0
SHDR CH	H	09	bit7	bit6	bit5	bit4	bit3	bit2	bit1	bit0
SHDR S-MODE	H	0A	bit7	bit6	bit5	bit4	bit3	bit2	bit1	bit0
SHDR CI	H	0B	bit7	bit6	bit5	bit4	bit3	bit2	bit1	bit0
CMADR L	H	0C	bit7	bit6	bit5	bit4	bit3	bit2	bit1	bit0
CMADR H	H	0D	X	bit14	bit13	bit12	bit11	bit10	bit9	bit8
MDFM	H	XE	X	X	X	RAW MD2	RAW MD1	RAW MD0	C MODE	C FORM
ADPCI	H	XF	MUTE	EMPH ASIS	EOR	BIT L4H8	X	FS L3H1	X	MONO STE
DMA XFRC-L	H	18	bit7	bit6	bit5	bit4	bit3	bit2	bit1	bit0
DMA XFRC-H	H	19	X	bit14	bit13	bit12	bit11	bit10	bit9	bit8
DMA ADRC-L	H	1A	bit7	bit6	bit5	bit4	bit3	bit2	bit1	bit0
DMA ADRC-H	H	1B	X	bit14	bit13	bit12	bit11	bit10	bit9	bit8
DRV ADRC-L	H	1C	bit7	bit6	bit5	bit4	bit3	bit2	bit1	bit0
DRV ADRC-H	H	1D	X	bit14	bit13	bit12	bit11	bit10	bit9	bit8
TEST 0 to 2	H	10 to 2	X	X	X	X	X	X	X	X

Read Registers

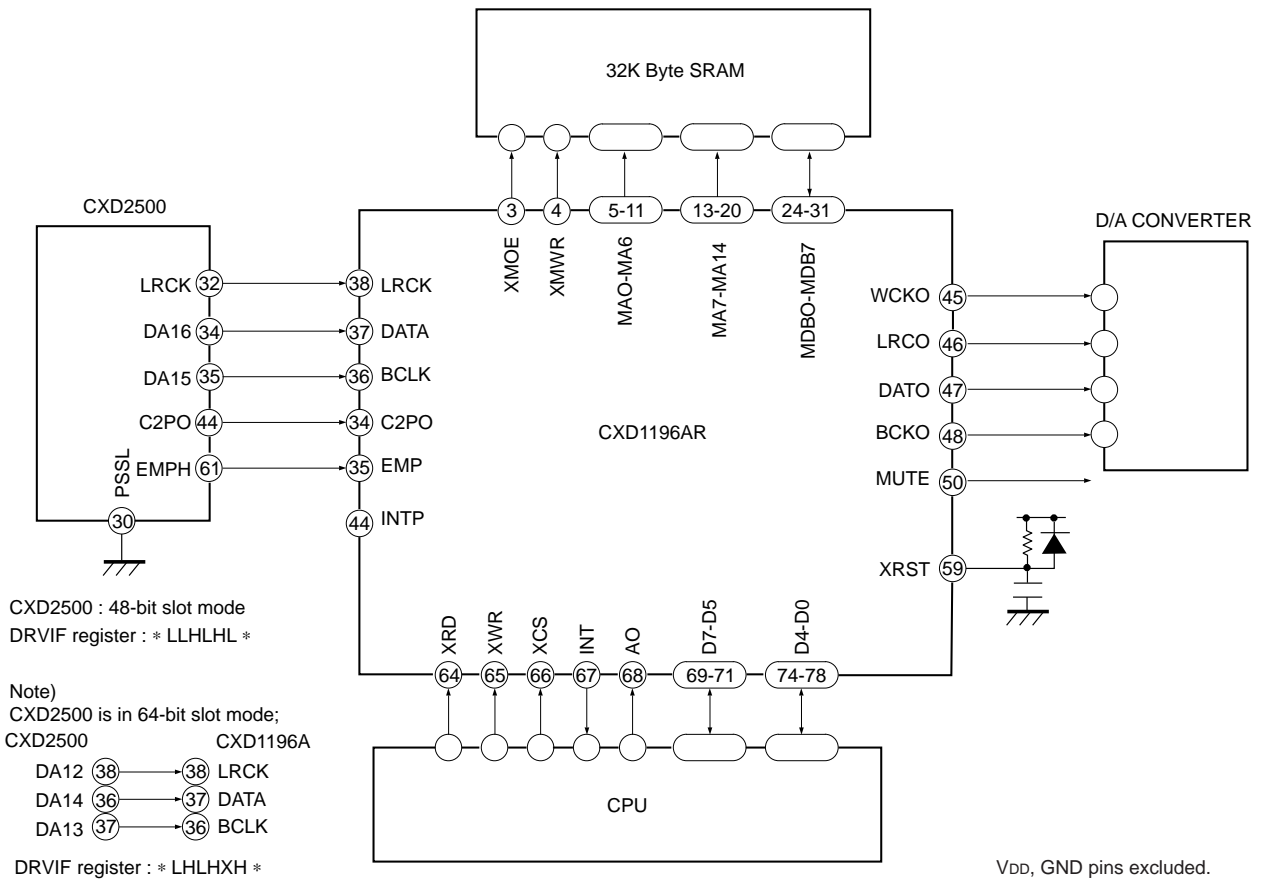

CXD1196AR Connection Diagram

Package Outline Unit : mm

80PIN LQFP (PLASTIC)

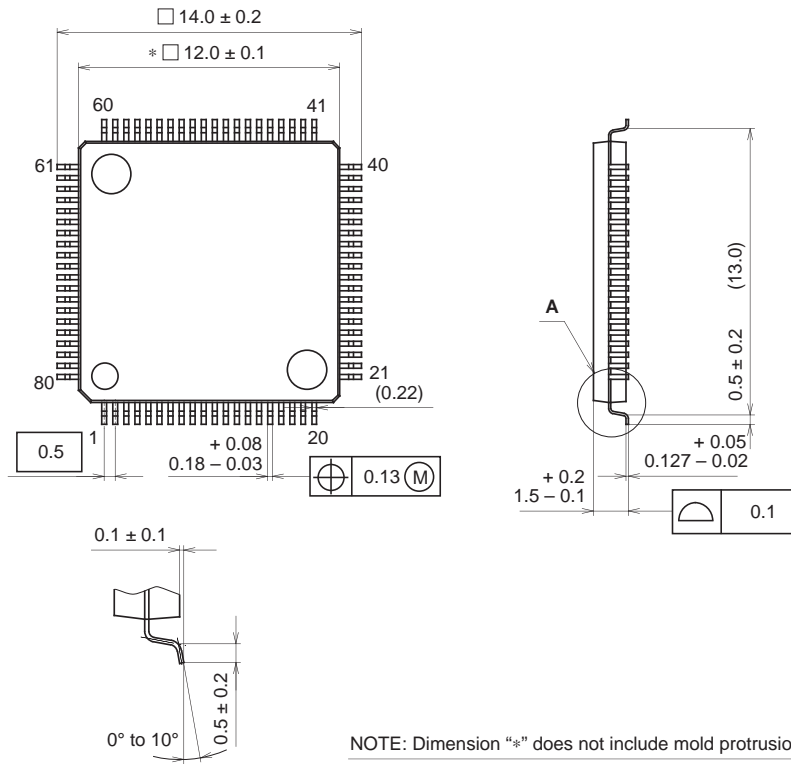

DETAIL A

PACKAGE STRUCTURE

SONY CODE	LQFP-80P-L01
EIAJ CODE	LQFP080-P-1212
JEDEC CODE	_____

PACKAGE MATERIAL	EPOXY RESIN
LEAD TREATMENT	SOLDER PLATING
LEAD MATERIAL	42 ALLOY
PACKAGE MASS	0.5g

This datasheet has been downloaded from:

www.DatasheetCatalog.com

Datasheets for electronic components.



LittleDiode supplies new, hard to find or obsolete electronic components and semiconductors all over the world.

With over two million different components listed you are sure to find the part you need.

Feel free to visit us today at our online store:

LittleDiode.com

Looking forward to providing you with the best possible service.