

Post-Amplifier for Optical Fiber Communication Receiver

Description

The CXB1577Q achieves the 2R optical-fiber communication receiver functions (Reshaping and Regenerating) on a single chip. This IC is equipped with the signal detection function, which is used to enable TTL/ECL outputs. Also, the output disable function performs the output shutdown. 3.3V/5.0V can be used for the supply voltage.

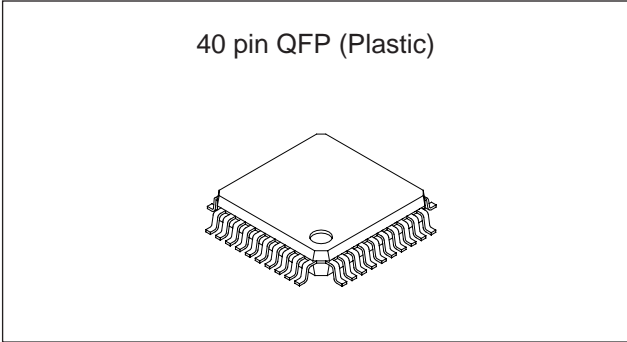

Features

- Output disable function (TTL input)
- Signal detection function (TTL/ECL output)
- Supply voltage supports both 3.3V/5.0V

Applications

- SONET/SDH: 622.08Mbps
- Fibre Channel: 531.25Mbps
: 1.062Gbps
- Gigabit-Ethernet: 1.25Gbps

Absolute maximum Ratings

• Supply voltage	$V_{CC} - V_{EE}$	-0.3 to +7	V
• Storage temperature	T_{stg}	-65 to +150	°C
• Input voltage difference $ V_D - V_{\bar{D}} $	V_{dif}	0 to +2	V
• SW input voltage	V_i	V_{EE} to V_{CC}	V
• ECL output current	$I_{oQ/SD-ECL}$	-30 to 0	mA
• TTL output current (High level)	$I_{oH SD-TTL}$	-20 to 0	mA
• TTL output current (Low level)	$I_{oL SD-TTL}$	0 to 20	mA

Recommended Operating Conditions

• Supply voltage	$V_{CC} - V_{EE}$	$3.3 \pm 0.2/5 \pm 0.25$	V
• Termination voltage (for data)	$V_{CC} - V_{TD}$	1.8 to 2.2	V
• Termination voltage (for alarm 1,alarm 2)	V_{TA}	V_{EE}	V
• Termination resistance (for data)	R_{TD}	46 to 56	Ω
• Termination resistance (for alarm 1)	R_{TA1}	240 to 300	Ω
• Termination resistance (for alarm 2)	R_{TA2}	460 to 560	Ω
• Operating temperature	T_a	-40 to +85	°C

Structure

Bipolar silicon monolithic IC

Sony reserves the right to change products and specifications without prior notice. This information does not convey any license by any implication or otherwise under any patents or other right. Application circuits shown, if any, are typical examples illustrating the operation of the devices. Sony cannot assume responsibility for any problems arising out of the use of these circuits.

Block Diagram and Pin Configuration

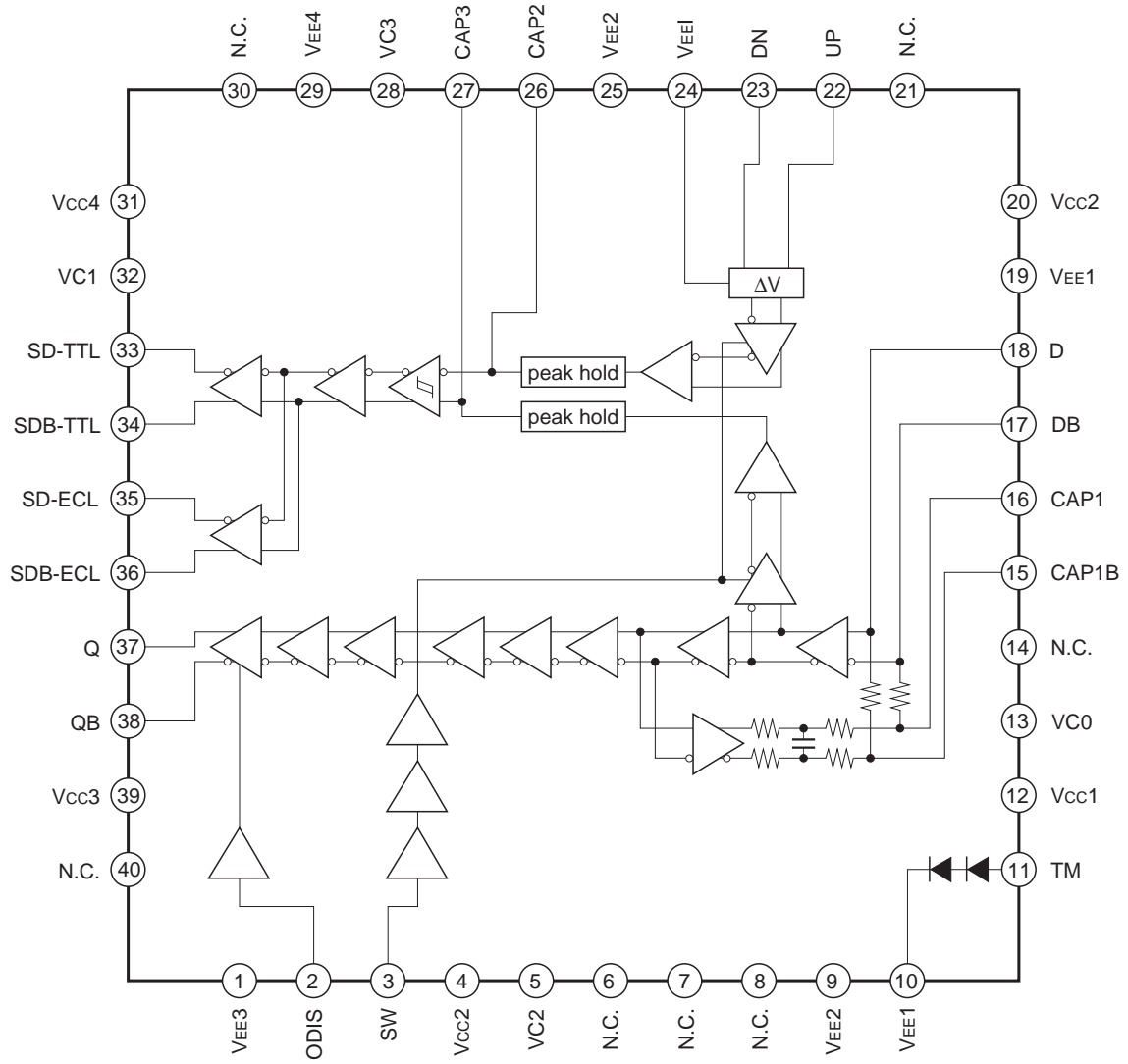

Pin Description

Pin No.	Symbol	Typical pin voltage		Equivalent circuit	Description
		DC	AC		
1	V _{EE3}	-3.3V /-5V			Negative power supply for ECL output buffer.
2	ODIS	0V (Open) or -3.3V /-5V			Controls the output shutdown function. High voltage when open; the Q output is fixed to Low. Low voltage when connected to V _{EE} ; the D input results in the Q output with ECL level. TTL level is also available.
3	SW	0V (Open) or -3.3V /-5V			Switches the identification maximum voltage amplitude. High voltage when open; the identification maximum voltage amplitude becomes 40mVp-p. Low voltage when connected to V _{EE} ; the amplitude becomes 20mVp-p.
4	V _{CC2}	0V			Positive power supply for digital block.
5	VC2	0V /-1.7V (Open)			Switches 3.3V/5V. Short this pin to V _{CC} for 3.3V between V _{CC} and V _{EE} . Leave this pin open for 5V between V _{CC} and V _{EE} .
6	N.C.				No connected.
7					
8					
9	V _{EE2}	-3.3V /-5V			Negative power supply for digital block.
10	V _{EE1}	-3.3V /-5V			Negative power supply for analog block.
11	TM	-1.8V /-3.5V			Chip temperature monitor.

Pin No.	Symbol	Typical pin voltage		Equivalent circuit	Description
		DC	AC		
12	Vcc1	0V			Positive power supply for analog block.
13	VC0	0V /-1.7V (Open)			Switches 3.3V/5V. Short this pin to Vcc for 3.3V between Vcc and VEE. Leave this pin open for 5V between Vcc and VEE.
14	N.C.				No connected.
15	CAP1B				Pins 15 and 16 connect a capacitor which determines the cut-off frequency for DC feedback block. Pins 17 and 18 are input pins for limiting amplifier block. Input the signal with AC coupled.
16	CAP1				
17	DB	-1.3V	-0.9V to -1.7V		
18	D	-1.3V	-0.9V to -1.7V		
19	VEE1	-3.3V /-5V			Negative power supply for analog block.
20	Vcc2	0V			Positive power supply for digital block.
21	N.C.				No connected.
22	UP				Connects a resistor for alarm level setting. Default voltage can be generated without an external resistor by shorting the VEE1 pin to VEE.
23	DN				
24	VEE1	-3.3V /-5V			Generates the default voltage between UP and DOWN. The voltage (8.0mV for input conversion) can be generated between UP and DOWN (Pins 22 and 23) as alarm setting level by connecting this pin to VEE.
25	VEE2	-3.3V /-5V			Negative power supply for digital block.

Pin No.	Symbol	Typical pin voltage		Equivalent circuit	Description
		DC	AC		
26	CAP2	-1.8V			<p>Connects a peak hold circuit capacitor for alarm block. 470pF should be connected to Vcc each.</p> <p>CAP2 pin connects a peak hold capacitor for alarm level setting block.</p> <p>CAP3 pin connects a peak hold capacitor for limiting amplifier signal.</p>
27	CAP3	-1.8V			<p>Connects a peak hold circuit capacitor for alarm block. 470pF should be connected to Vcc each.</p> <p>CAP2 pin connects a peak hold capacitor for alarm level setting block.</p> <p>CAP3 pin connects a peak hold capacitor for limiting amplifier signal.</p>
28	VC3	0V /-1.7V (Open)			<p>Switches 3.3V/5V. Short this pin to Vcc for 3.3V between Vcc and VEE. Leave this pin open for 5V between Vcc and VEE.</p>
29	VEE4	-3.3V /-5V			Negative power supply for TTL output buffer.
30	N.C.				No connected.
31	Vcc4	0V			Positive power supply for TTL output buffer.
32	VC1	0V -1.7V (Open)			<p>Switches 3.3V/5V. Short this pin to Vcc for 3.3V between Vcc and VEE. Leave this pin open for 5V between Vcc and VEE.</p>

Pin No.	Symbol	Typical pin voltage		Equivalent circuit	Description
		DC	AC		
33	SD-TTL		V_{EE} or $V_{EE} + 3V$		Alarm signal TTL level output.
34	SDB-TTL		V_{EE} or $V_{EE} + 3V$		Alarm signal TTL level output.
35	SD-ECL		$-0.9V$ or $-1.7V$		Alarm signal ECL level output. Terminate this pin in 510Ω to V_{EE} at $V_{EE} = 5V$; in 270Ω to V_{EE} at $V_{EE} = 3.3V$.
36	SDB-ECL		$-0.9V$ or $-1.7V$		

Pin No.	Symbol	Typical pin voltage		Equivalent circuit	Description
		DC	AC		
37	Q		-0.9V or -1.7V		<p>Data signal output. Terminates this pin in 50Ω to $V_{TT} = V_{cc} - 2V$.</p>
38	QB		-0.9V or -1.7V		
39	Vcc3	0V			Positive power supply for ECL output buffer.
40	N.C.				No connected.

Electrical Characteristics

DC Characteristics

$V_{CC} = GND$, $V_{EE} = -5V \pm 5\%$, $T_a = -40$ to $+85^\circ\text{C}$, $VC0$ to $VC3 = \text{open}$,
or $V_{CC} = GND$, $V_{EE} = -3.3V \pm 5\%$, $T_a = -40$ to $+85^\circ\text{C}$, $VC0$ to $VC3 = GND$

Item	Symbol	Conditions	Min.	Typ.	Max.	Unit
Supply current	I_{EE}		-74	-51	-34	mA
Q/QB High output voltage	V_{OH}	50Ω to V_{TT}	-1100		-860	mV
Q/QB Low output voltage	V_{OL}	$T_a = 0$ to $+85^\circ\text{C}$	-1860		-1620	
SD-ECL/SDB-ECL High output voltage	V_{OH-E}	When $V_{CC} - V_{EE} = 5.0V$, 510Ω to V_{EE} ; when $V_{CC} - V_{EE} = 3.3V$, 270Ω to V_{EE}	-1100		-860	mV
SD-ECL/SDB-ECL Low output voltage	V_{OL-E}	$T_a = 0$ to $+85^\circ\text{C}$	-1890		-1650	
SD-TTL/SDB-TTL High output voltage 1	V_{OH-T1}	$I_{OH} = -0.4\text{mA}$, $V_{CC} - V_{EE} = 3.3V$, $T_a = 0$ to $+85^\circ\text{C}$	$V_{EE} + 2.2$			V
SD-TTL/SDB-TTL High output voltage 2	V_{OH-T2}	$I_{OH} = -0.4\text{mA}$, $V_{CC} - V_{EE} = 5V$, $T_a = 0$ to $+85^\circ\text{C}$	$V_{EE} + 2.4$			
SD-TTL/SDB-TTL Low output voltage	V_{OL-T}	$I_{OL} = 2\text{mA}$ $T_a = 0$ to $+85^\circ\text{C}$			$V_{EE} + 0.5$	
SW High input voltage	V_{IHSW}	at SW pin Open: High	$V_{CC} - 0.5$		V_{CC}	
SW Low input voltage	V_{ILSW}		V_{EE}		$V_{EE} + 0.5$	μA
SW High input current	I_{IHSW}				10	
SW Low input current	I_{ILSW}		-100			V
ODIS High input voltage	V_{IHOD}	at ODIS pin Open: High	$V_{EE} + 2.0$		$V_{CC} + 0.5$	
ODIS Low input voltage	V_{ILOD}		V_{EE}		$V_{EE} + 0.8$	μA
ODIS High input current	I_{IHOD}				20	
ODIS Low input current	I_{ILOD}		-400			Ω
D/DB input resistance	R_{in}		765	1020	1275	

AC Characteristics

$V_{CC} = GND$, $V_{EE} = -5V \pm 5\%$, $T_a = -40$ to $+85^\circ\text{C}$, $VC0$ to $VC3 = \text{open}$,
or $V_{CC} = GND$, $V_{EE} = -3.3V \pm 5\%$, $T_a = -40$ to $+85^\circ\text{C}$, $VC0$ to $VC3 = GND$

Item	Symbol	Conditions	Min.	Typ.	Max.	Unit
Maximum input voltage amplitude	Vmax	single-ended input	1600			mVp-p
Amplifier gain (excluding the output buffer)	GL		52			dB
Identification maximum voltage amplitude of alarm level	VmaxA1	SW pad: Low, single-ended input	20			mVp-p
	VmaxA2	SW pad: Open High, single-ended input	40			
SD/SDB hysteresis width	$\Delta P1$	SW pin: Low, at default alarm level	3	6	7	dB
	$\Delta P2$	SW pin: Open High, at default alarm level	3	6	7	
Alarm setting level for default	Vdef	UP/DOWN pin: open, $V_{EEL} = V_{EE}$, Differential voltage input	7.0	8.4	9.7	mV
Q/QB rise time	TrQ	20% to 80% 50 Ω to VTT		230	350	ps
Q/QB fall time	TfQ			230	350	
SD-TTL/SDB-TTL rise time	TrSDT	$V_{EE} + 0.8V$ to $V_{EE} + 2.0V$ $C_L = 10pF$			10	ns
SD-TTL/SDB-TTL fall time	TfSDT				10	
SD-ECL/SDB-ECL rise time	TrSDE	20% to 80% When $V_{CC} - V_{EE} = 5.0V$, 510 Ω to V_{EE} , when $V_{CC} - V_{EE} = 3.3V$, 270 Ω to V_{EE}			1.6	
SD-ECL/SDB-ECL fall time	TfSDE				1.6	
Propagation delay time	TPD		0.4		1.9	
SD response assert time	Tas	*1	0		100	μs
SD response deassert time	Tdas	*2	2.3		100	
SD response assert time for alarm level default	Tasd	*3	0		100	
SD response deassert time for alarm level default	Tdasd	*4	2.3		100	

*1 $V_{UP} - V_{DOWN} = 100mV$, $V_{in} = 100mVp-p$ (single ended), SW pin: High, peak hold capacitance (CAP2, CAP3 pins) of 470pF, connect V_{EEL} to V_{EE} .

*2 $V_{UP} - V_{DOWN} = 100mV$, $V_{in} = 1Vp-p$ (single ended), SW pin: High, peak hold capacitance (CAP2, CAP3 pins) of 470pF, connect V_{EEL} to V_{EE} .

*3 $V_{in} = 50mVp-p$ (single ended), SW pin: Low, peak hold capacitance of 470pF, connect V_{EEL} to V_{EE} .

*4 $V_{in} = 1Vp-p$ (single ended), SW pin: Low, peak hold capacitance of 470pF, connect V_{EEL} to V_{EE} .

DC Electrical Characteristics Measurement Circuit

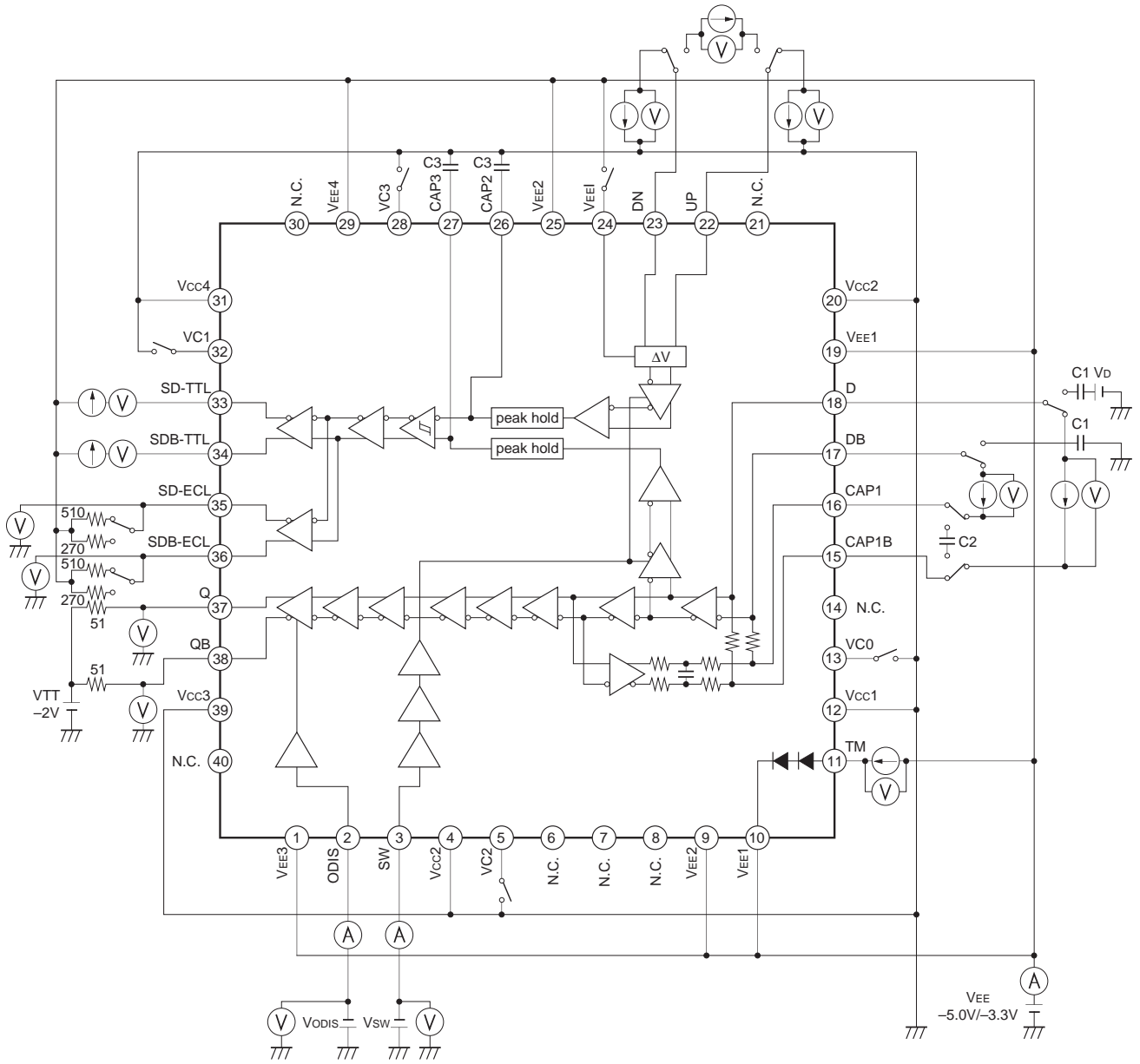

* When VEE = -5.0V: VC0 to VC3 = open
 When VEE = -3.3V: VC0 to VC3 = Vcc

AC Electrical Characteristics Measurement Circuit

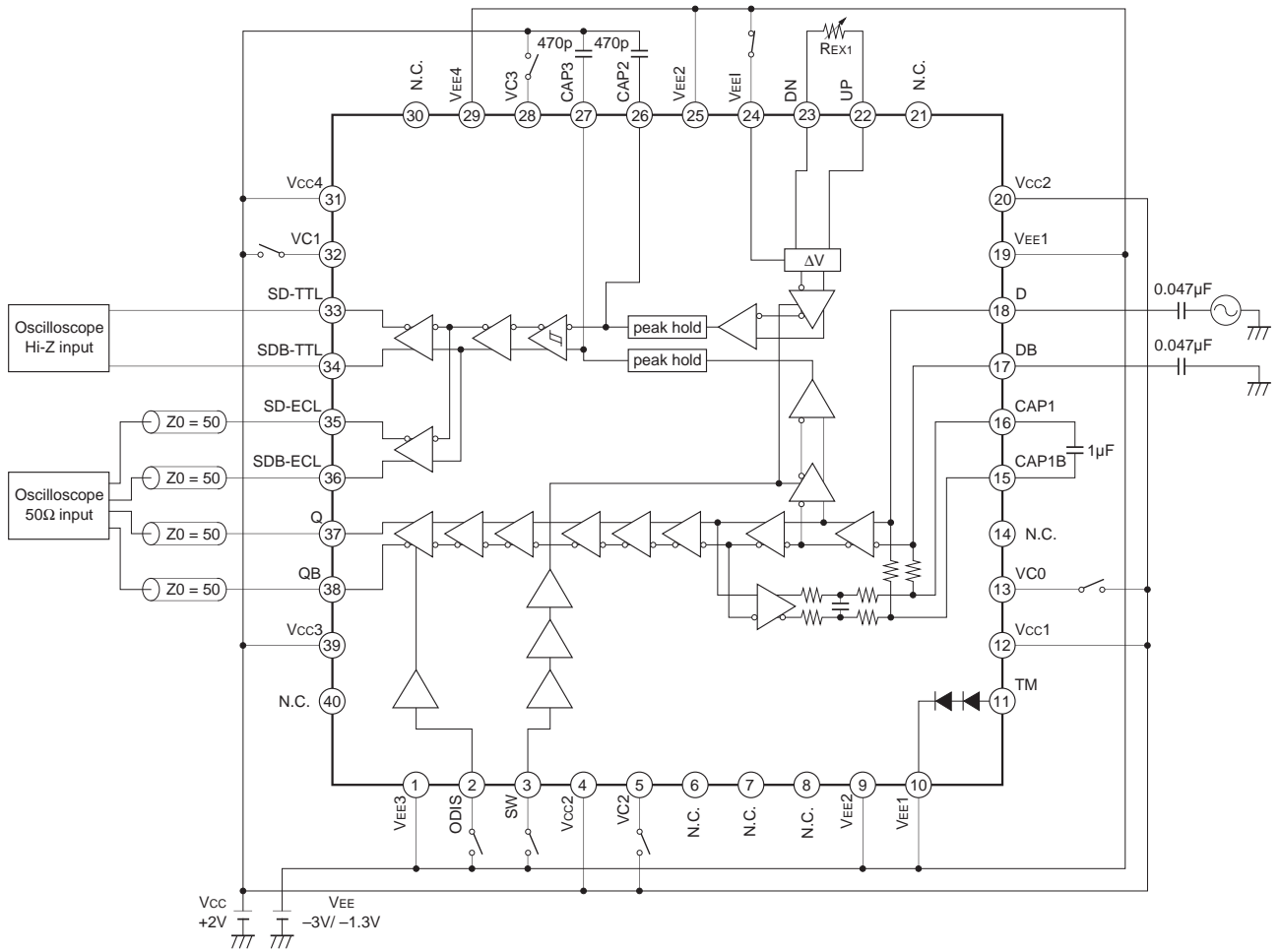

* When VEE = -3.0V: VC0 to VC3 = open
 When VEE = -1.3V: VC0 to VC3 = Vcc

Application Circuit

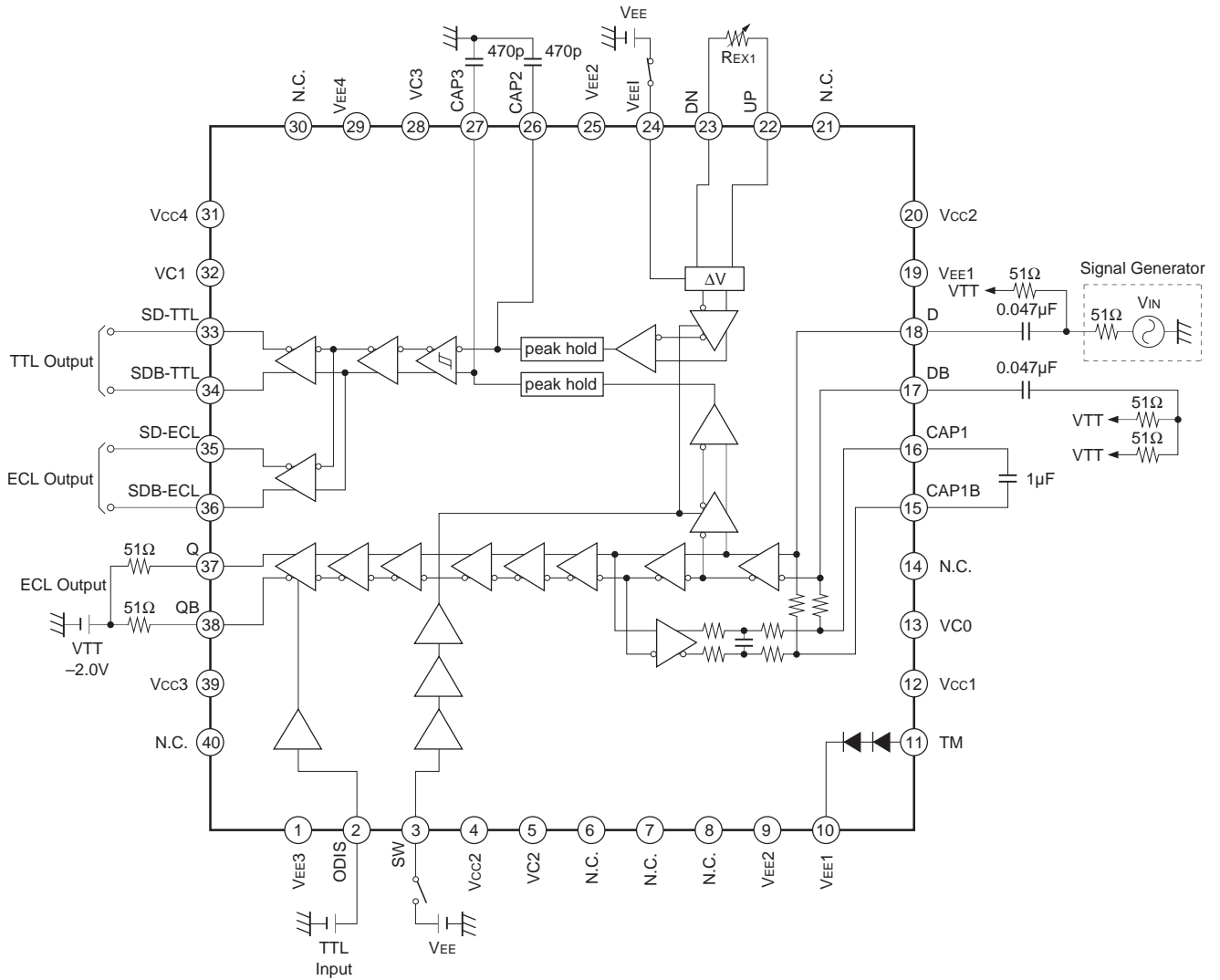

* When VEE = -3.3V: VC0 to VC3 = Vcc
 When VEE = -5.0V: VC0 to VC3 = open

Application circuits shown are typical examples illustrating the operation of the devices. Sony cannot assume responsibility for any problems arising out of the use of these circuits or for any infringement of third party patent and other right due to same.

Notes on Operation

1. Limiting amplifier block

The limiting amplifier block is equipped with the auto-offset canceler circuit. When external capacitors C1 and C2 are connected as shown in Fig. 1, the DC bias is set automatically in this block. External capacitor C1 and IC internal resistor R1 determine the low input cut-off frequency f_2 as shown in Fig. 2. Similarly, external capacitor C2 and IC internal resistor R2 determine the high cut-off frequency f_1 for DC bias feedback. Since peaking characteristics may occur in the low frequency area of the amplifier gain characteristics depending on the f_1/f_2 combination, set the C1 and C2 values so as to avoid the occurrence of peaking characteristics. The target values of R1 and R2 and the typical values of C1 and C2 are as indicated below. When a single-ended input is used, provide AC grounding by connecting Pin 17 to a capacitor which has the same capacitance as capacitor C1.

R1 (internal): 1k Ω	} f2: 3.4kHz	R2 (internal): 7.5k Ω	} f1: 21Hz
C1 (external): 0.047 μ F		C2 (external): 1 μ F	

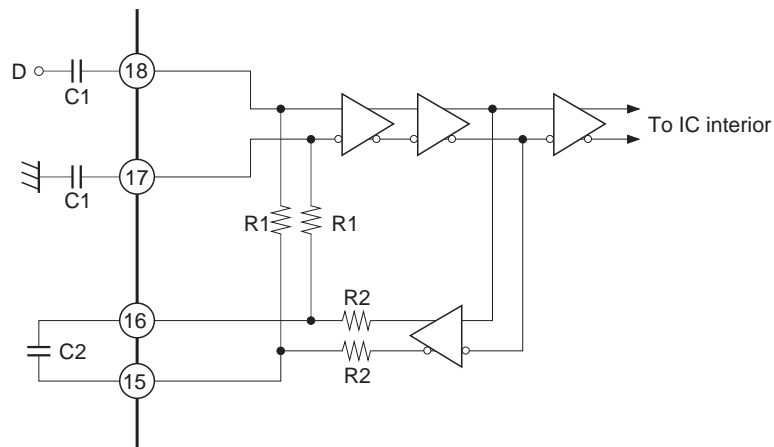

Fig. 1

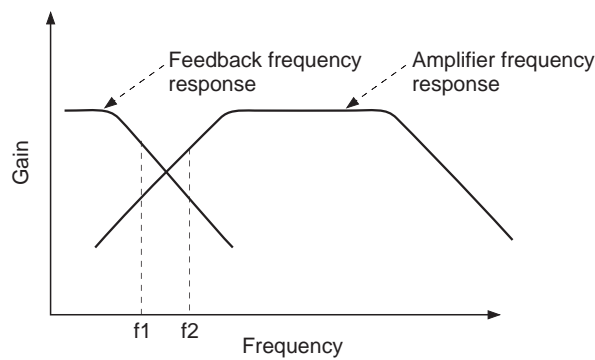

Fig. 2

2. Alarm block

In order to operate the alarm block, give the voltage difference between Pins 22 and 23 to set an alarm level and connect the peak hold capacitor C3 shown in Fig. 3.

This IC has two setting methods of alarm level; one is to connect Pin 24 to VEE and leave Pins 22 and 23 open to set an alarm level default value (8mV for input conversion). The other is to connect Pin 24 to VEE and set a desired alarm level using the external resistors REX1, REX2 and REX3 shown in Fig. 3. Connect REX1 between Pins 22 and 23 or connect REX3 between Pin 23 and Vcc when less alarm level is desired to be set than its default value; connect REX2 between Pin 22 and Vcc when more alarm level is desired to be set than its default value. However, the Pin 22 voltage must be higher than that of Pin 23.

This IC also features two-level setting of identification maximum voltage amplitude. The amplitude is set to 40mVp-p when Pin 3 is left open (High level) and it is set to 20mVp-p when Pin 3 is Low level. Therefore, the noise margin can be increased by setting Pin 3 to Low level when the small signal is input. The relation of input voltage and peak hold output voltage is shown in Fig. 5.

In the relation between the alarm setting level and hysteresis width, the hysteresis width is designed to maintain a constant gain (design target value: 6dB) as shown in Fig. 4.

This IC is designed to externally have the capacitor C3, and the C3 value should be set so as to obtain desired assert time and deassert time settings for the alarm signal.

The electrical characteristics for the SD response assert and deassert times are guaranteed only when the waveforms are input as shown in the timing chart of Fig. 6.

REX1: 100Ω (when the alarm level is set to 4mV for input conversion.)

REX2: 8kΩ (when the alarm level is set to 10mV for input conversion.)

REX3: 4kΩ (when the alarm level is set to 4mV for input conversion.)

C3: 470pF

The table below shows the alarm logic.

Optical signal input state	SD	\overline{SD}
Signal input	High level	Low level
Signal interruption	Low level	High level

The table below shows the output disable function logic.

Optical signal input state	Q	\overline{Q}
ODIS: Open High	Fixed Low	Fixed High
ODIS: Low	Data	\overline{Data}

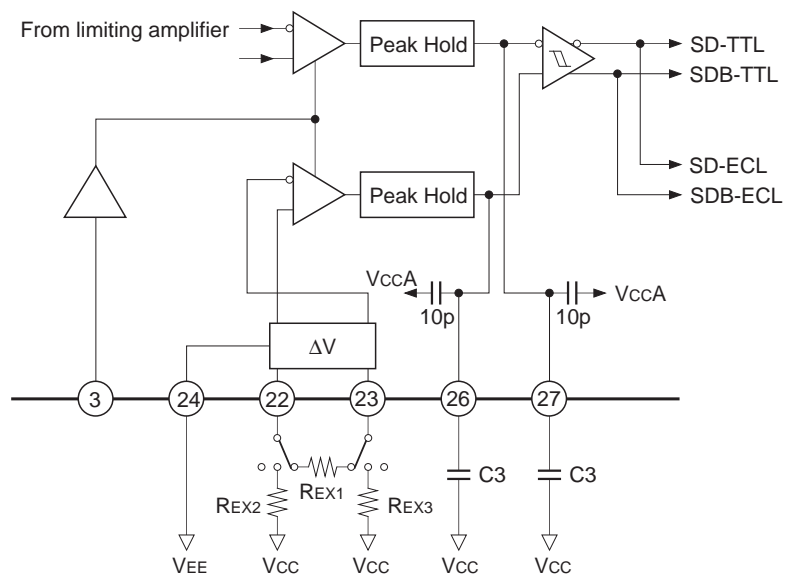
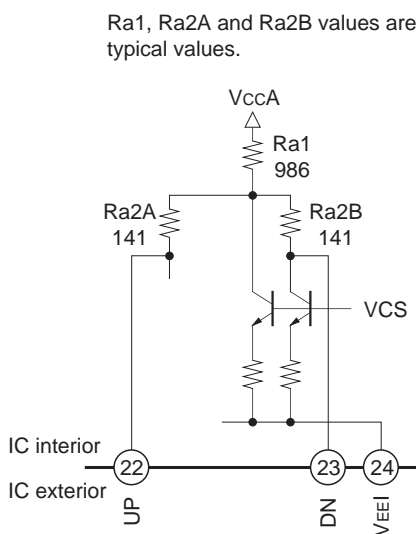

Fig. 3

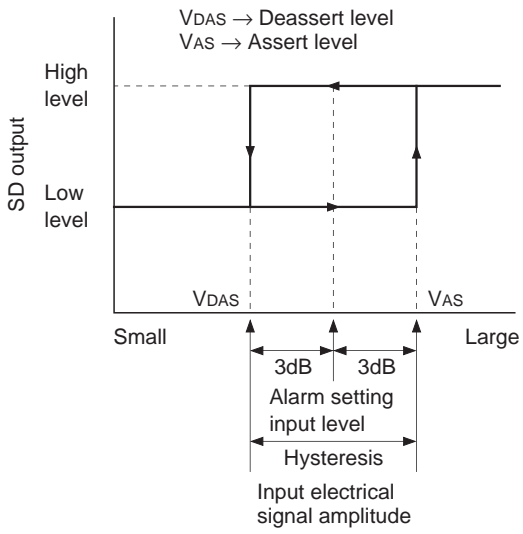

Fig. 4

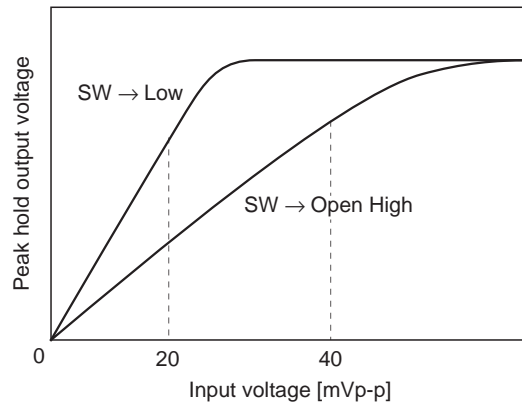

Fig. 5

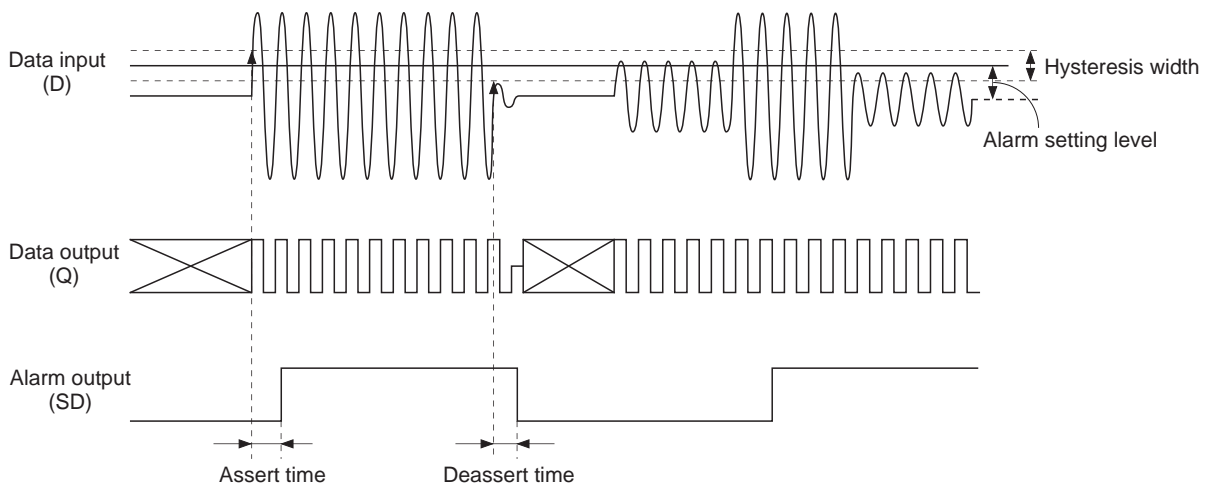
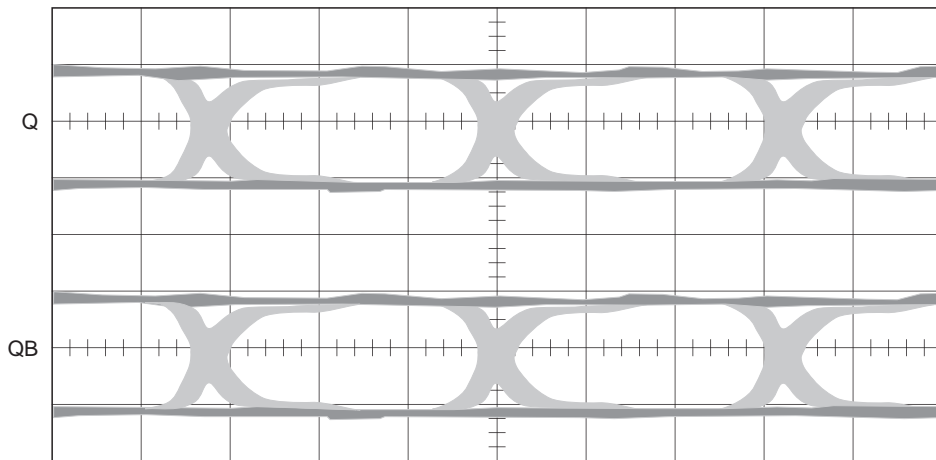

Fig. 6

Example of Representative Characteristics

1. Q/QB output waveform



V_{CC} = GND
 V_{EE} = -3.3V
 V_{TT} = -2V
 T_a = 27°C
 D = 622Mbps
 V_{in} = 5mVp-p
 Single input
 pattern: PRBS2²³-1
 Q/QB = 50Ω to V_{TT}

Ch. 1 = 400mV/div OFFSET = -1330mV, Ch. 2 = 400mV/div OFFSET = -1330mV, Timebase = 500ps/div

Fig. 7

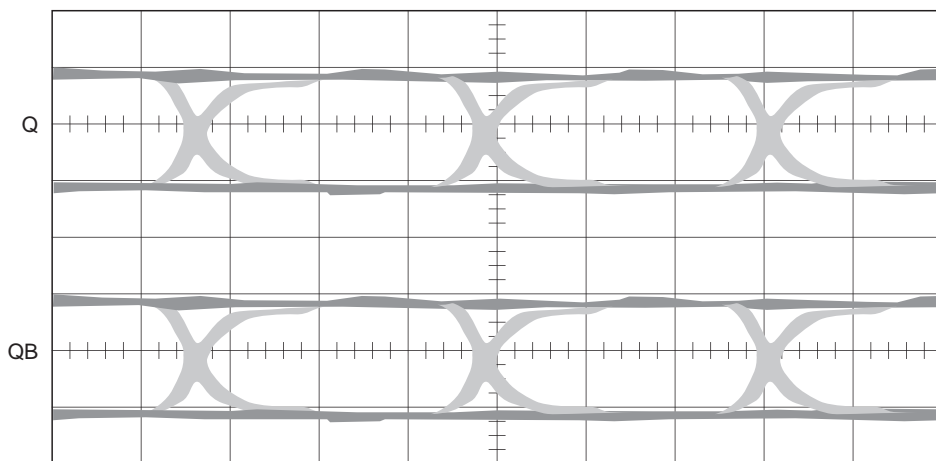

V_{CC} = GND
 V_{EE} = -3.3V
 V_{TT} = -2V
 T_a = 27°C
 D = 622Mbps
 V_{in} = 10mVp-p
 Single input
 pattern: PRBS2²³-1
 Q/QB = 50Ω to V_{TT}

Ch. 1 = 400mV/div OFFSET = -1330mV, Ch. 2 = 400mV/div OFFSET = -1330mV, Timebase = 500ps/div

Fig. 8

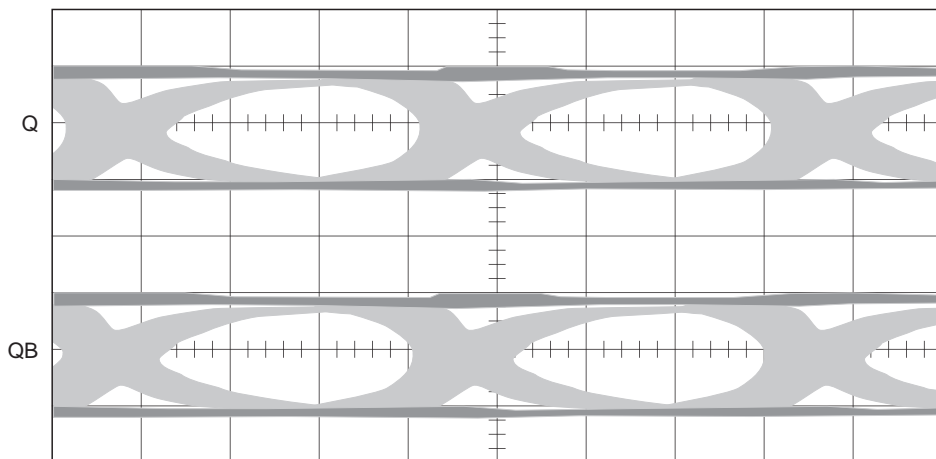

V_{CC} = GND
 V_{EE} = -3.3V
 V_{TT} = -2V
 T_a = 27°C
 D = 1.25Gbps
 V_{in} = 5mVp-p
 Single input
 pattern: PRBS2²³-1
 Q/QB = 50Ω to V_{TT}

Ch. 1 = 400mV/div OFFSET = -1330mV, Ch. 2 = 400mV/div OFFSET = -1330mV, Timebase = 200ps/div

Fig. 9

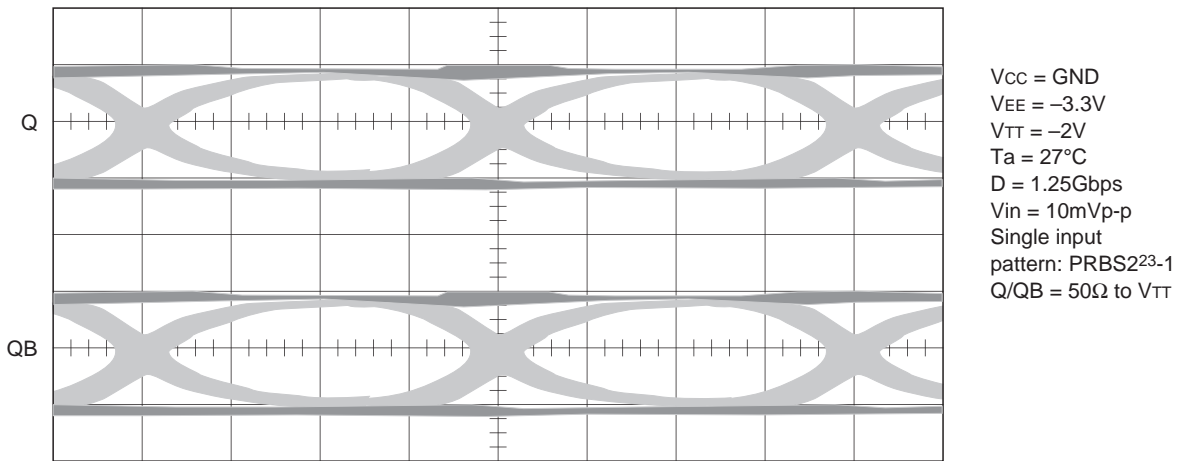

Ch. 1 = 400mV/div OFFSET = -1330mV, Ch. 2 = 400mV/div OFFSET = -1330mV, Timebase = 200ps/div

Fig. 10

2. Bit error rate

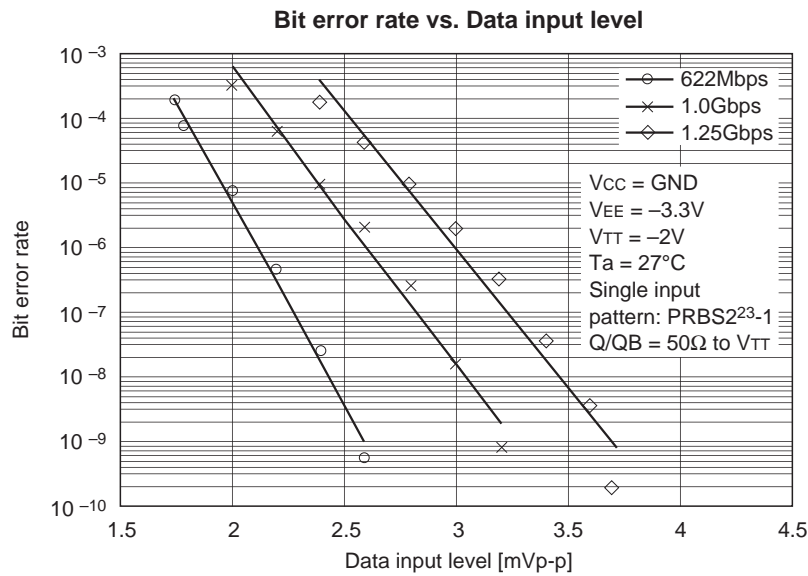

Fig. 11

3. Alarm level

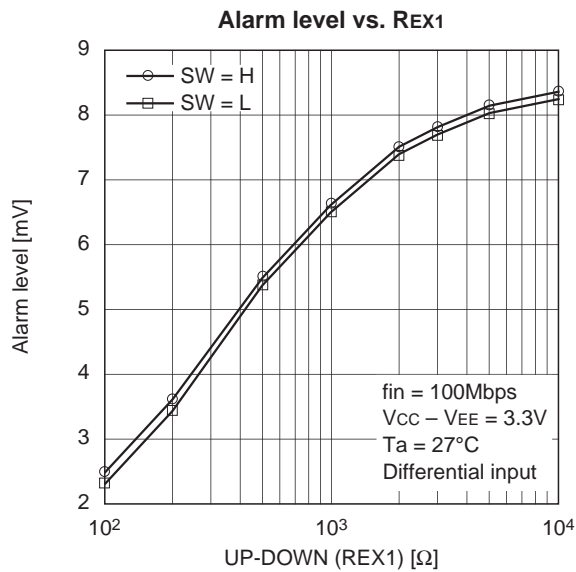

Fig. 12

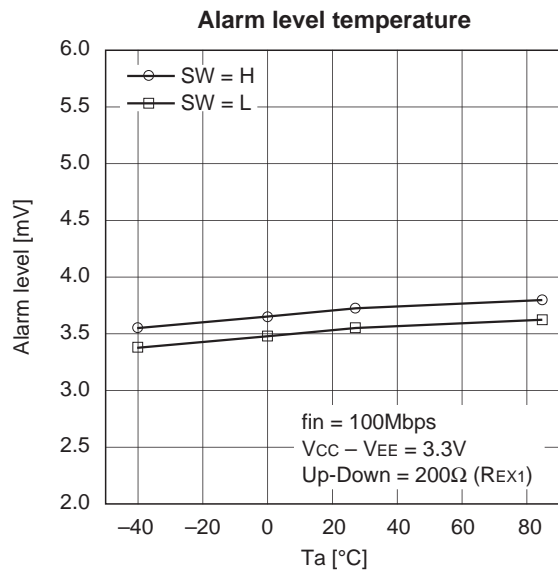

Fig. 13

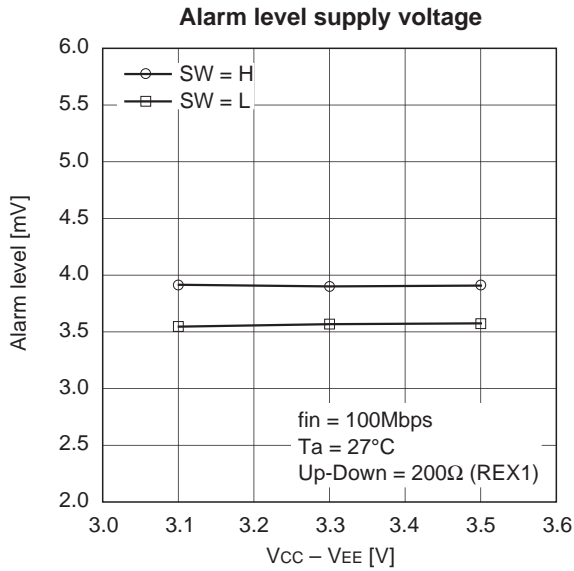

Fig. 14

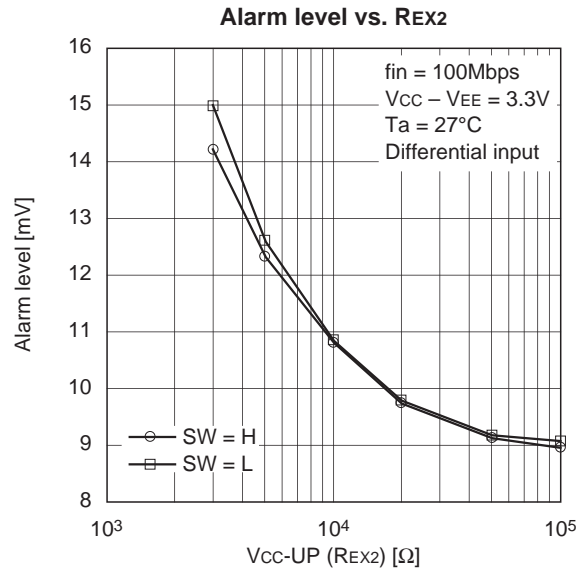

Fig. 15

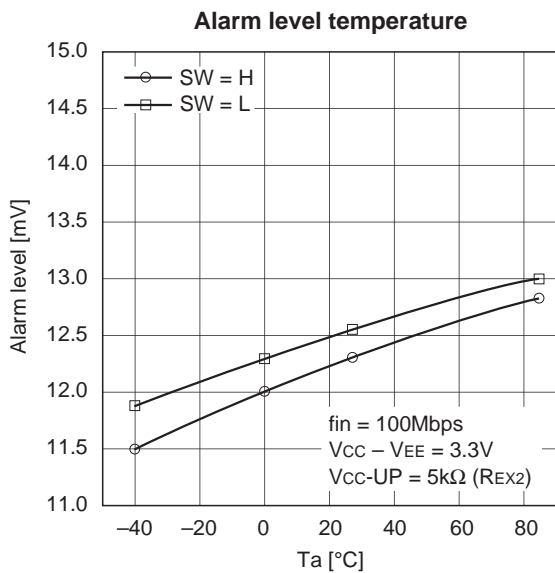

Fig. 16

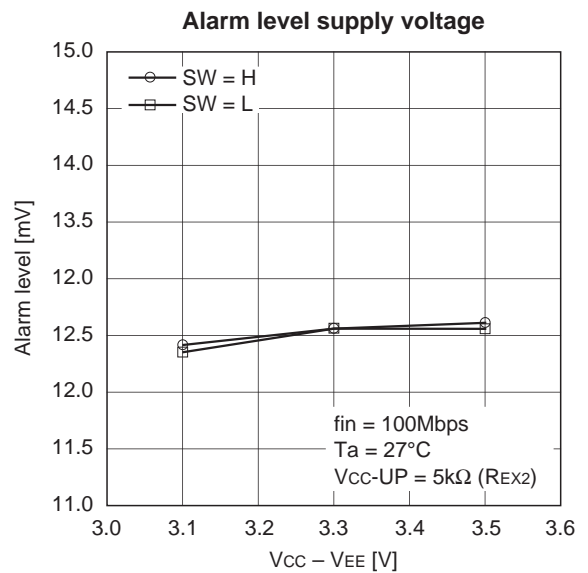

Fig. 17

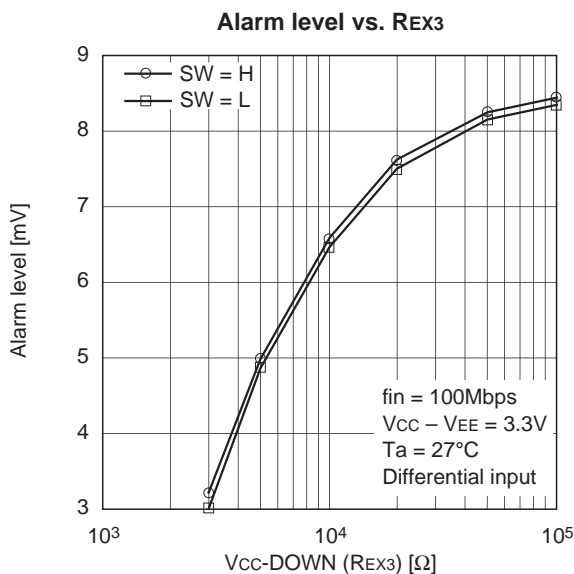

Fig. 18

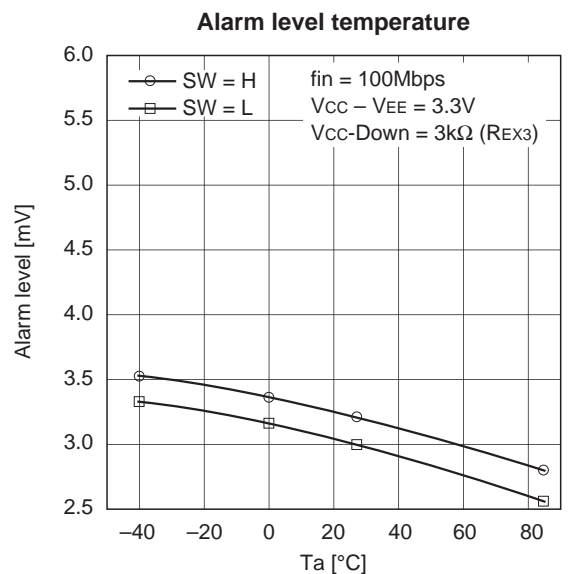

Fig. 19

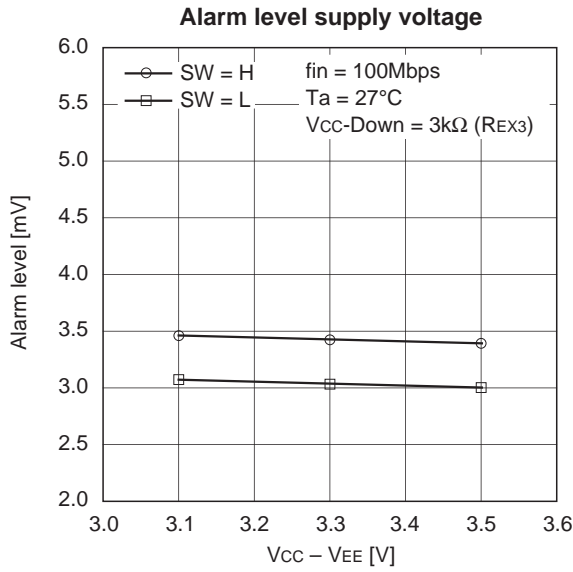

Fig. 20

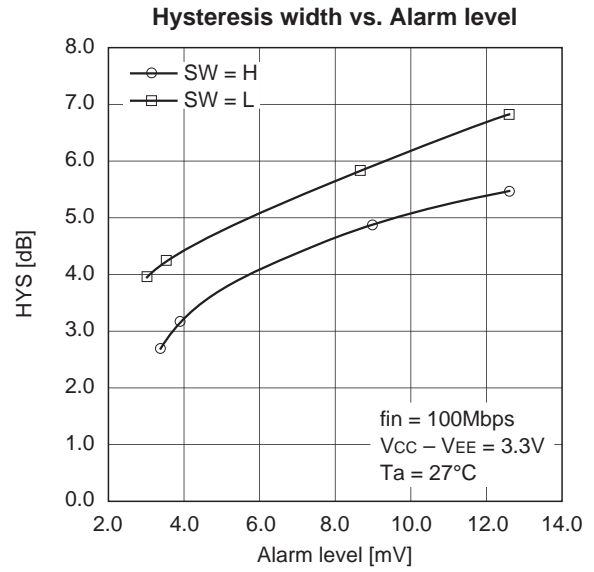

Fig. 21

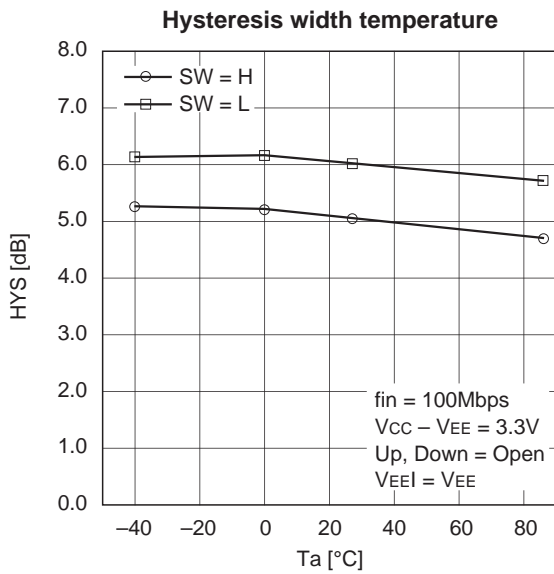

Fig. 22

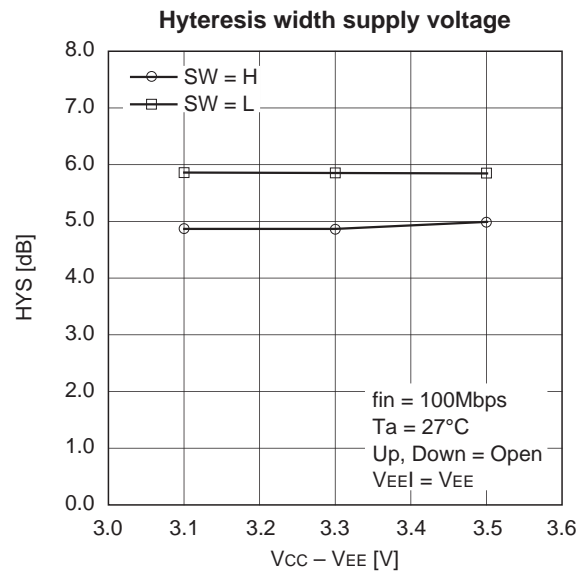

Fig. 23

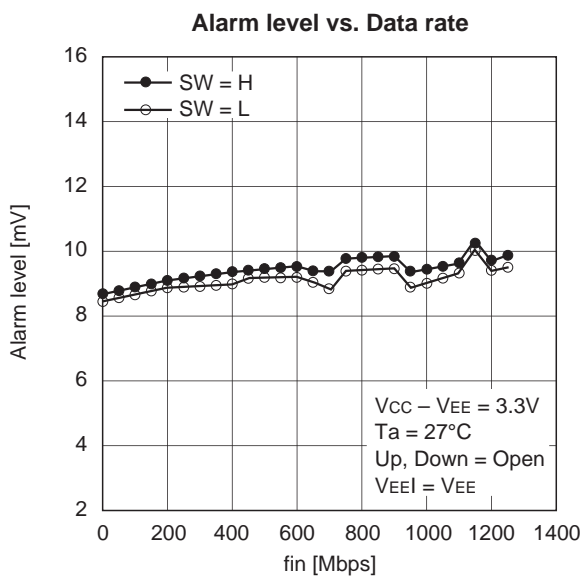

Fig. 24

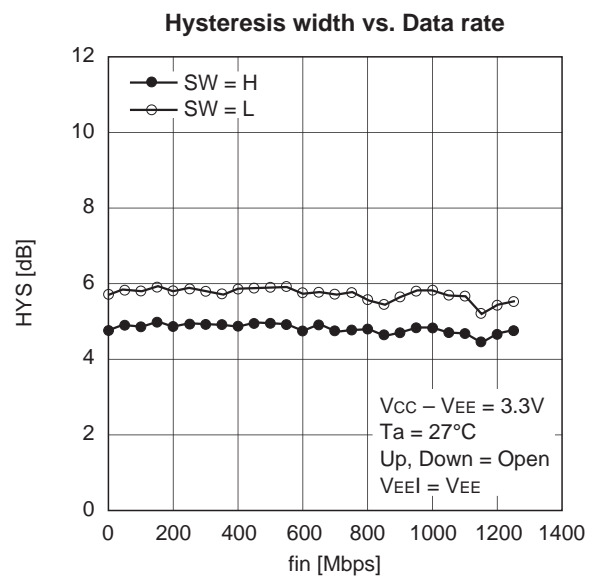

Fig. 25

4. DC voltage

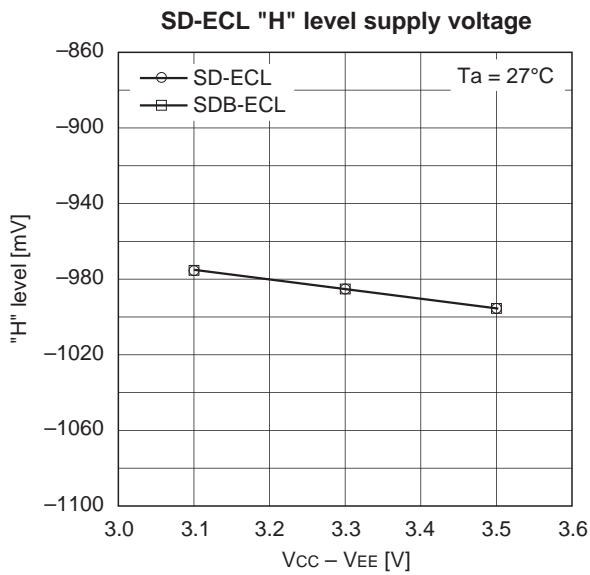

Fig. 26

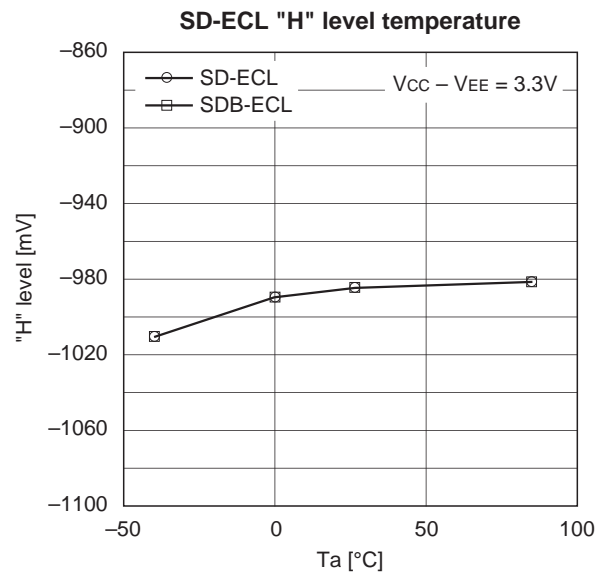

Fig. 27

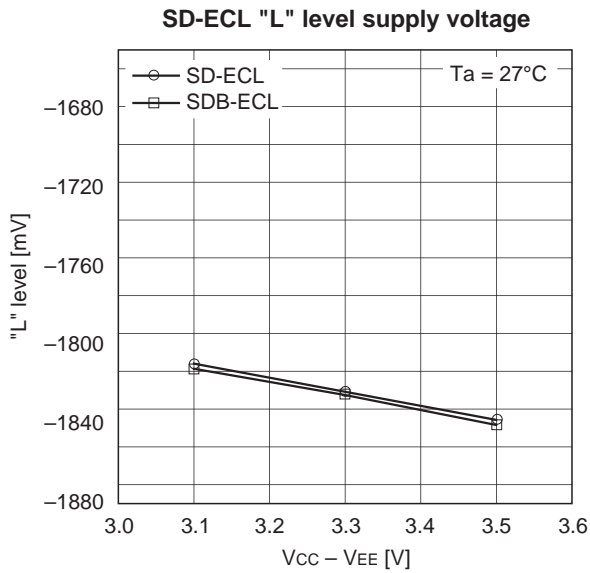

Fig. 28

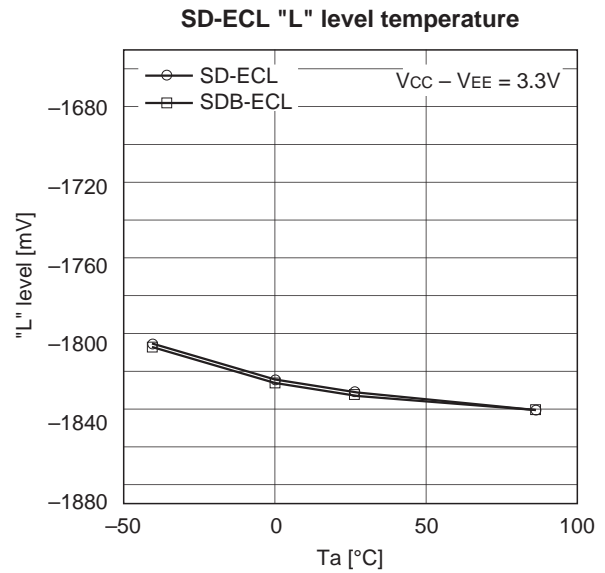

Fig. 29

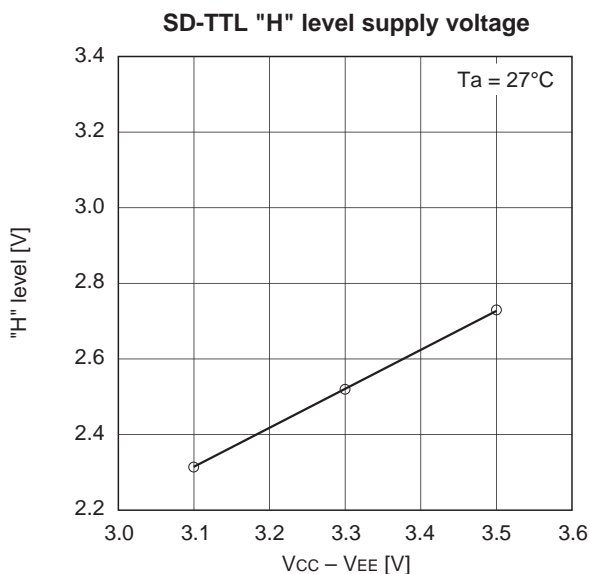

Fig. 30

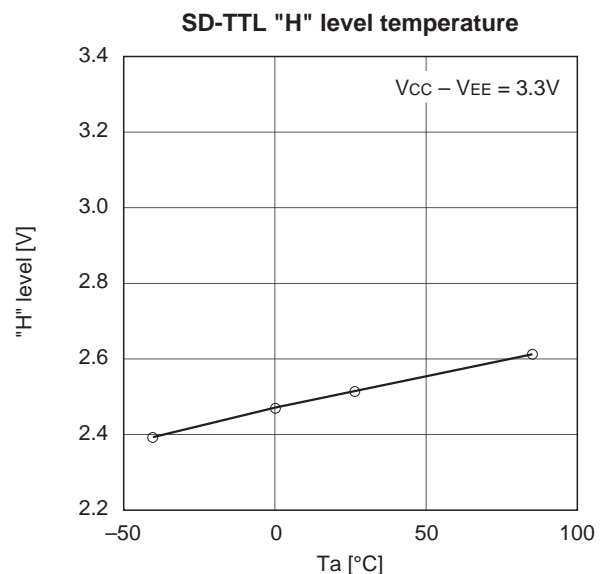

Fig. 31

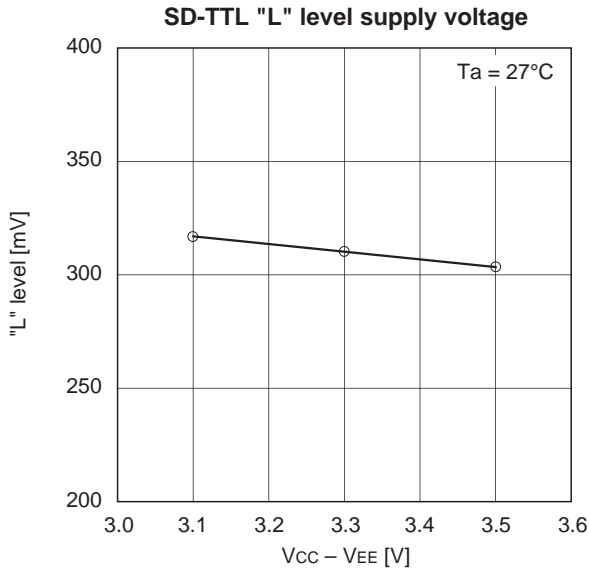

Fig. 32

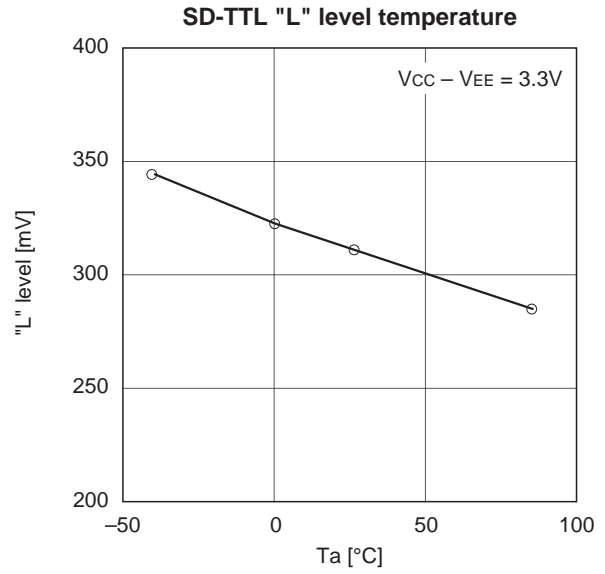

Fig. 33

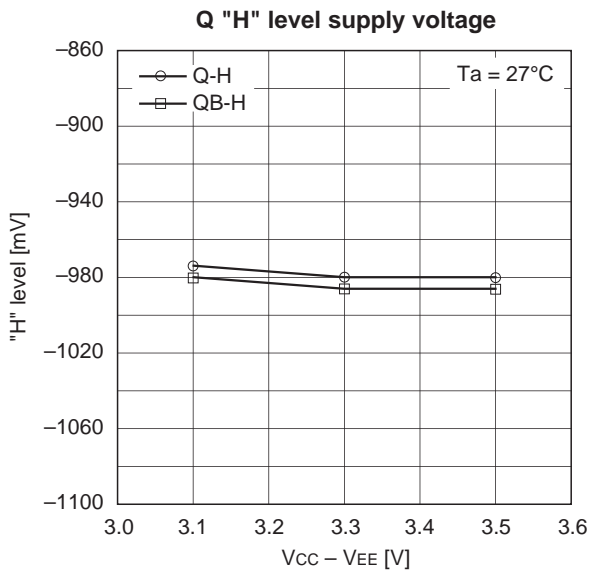

Fig. 34

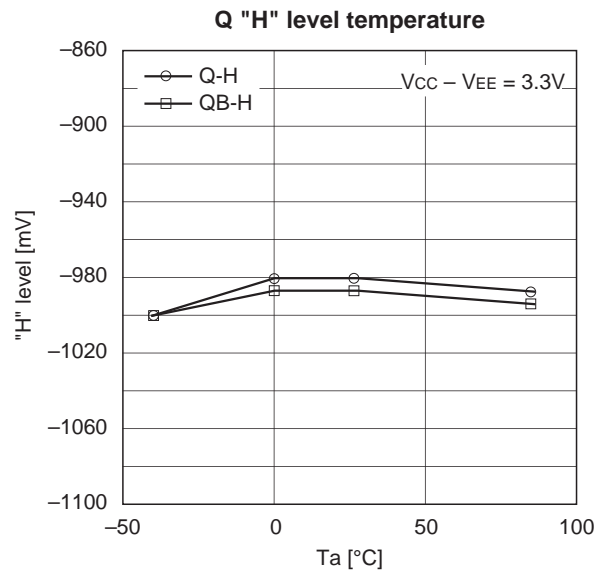

Fig. 35

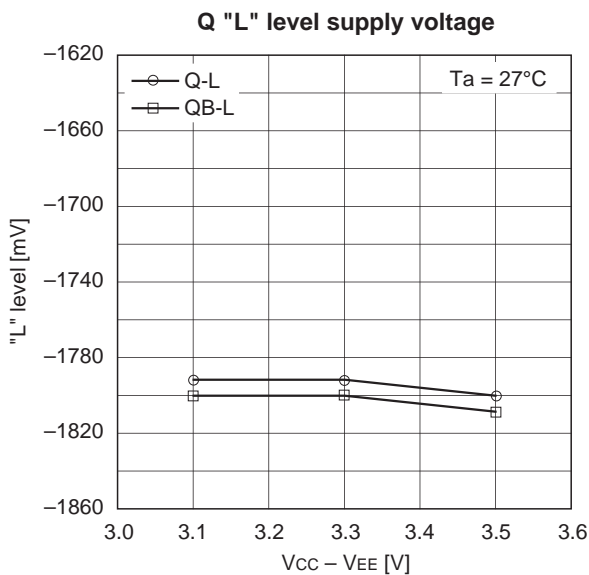

Fig. 36

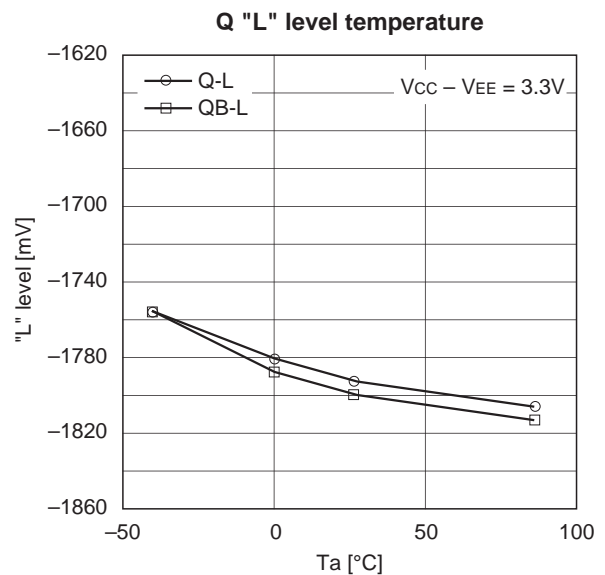
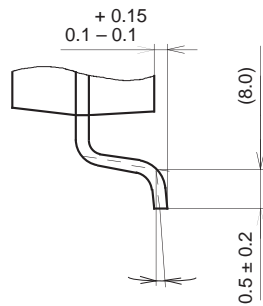
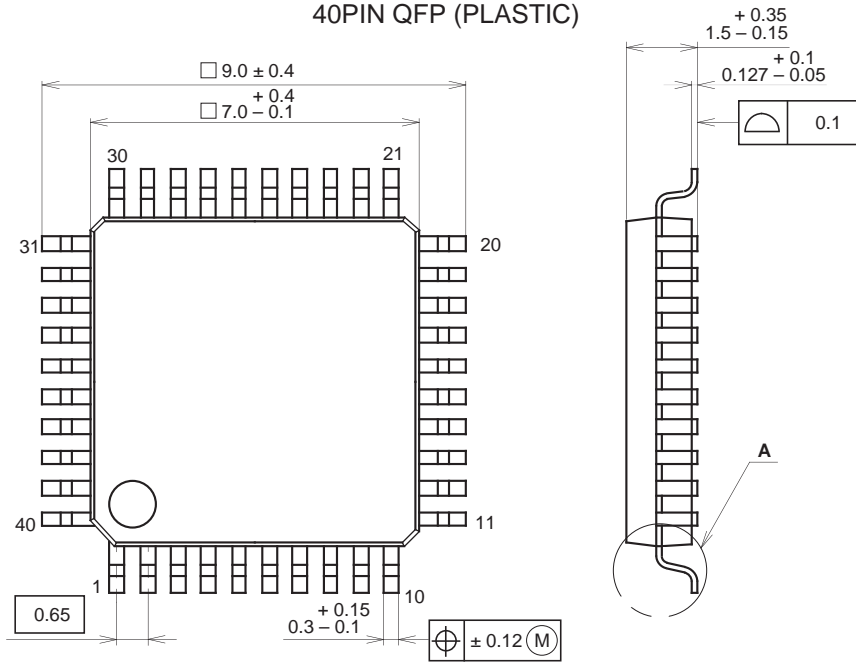

Fig. 37

Package Outline

Unit: mm

40PIN QFP (PLASTIC)



DETAIL A

SONY CODE	QFP-40P-L01
EIAJ CODE	QFP040-P-0707
JEDEC CODE	_____

PACKAGE STRUCTURE

PACKAGE MATERIAL	EPOXY RESIN
LEAD TREATMENT	SOLDER / PALLADIUM PLATING
LEAD MATERIAL	42/COPPER ALLOY
PACKAGE MASS	0.2g

NOTE : PALLADIUM PLATING

This product uses S-PdPPF (Sony Spec.-Palladium Pre-Plated Lead Frame).



LittleDiode supplies new, hard to find or obsolete electronic components and semiconductors all over the world.

With over two million different components listed you are sure to find the part you need.

Feel free to visit us today at our online store:

LittleDiode.com

Looking forward to providing you with the best possible service.