

## Limiting Amplifier for Optical Fiber Communication Receiver

### Description

The CXB1567Q achieves the 2R optical-fiber communication receiver functions (Reshaping and Regenerating) on a single chip. This IC is also equipped with the signal interruption alarm output function, which is used to discriminate the existence of data input.

### Features

- Auto-offset canceller circuit
- Signal interruption alarm outputs
- Single 5V power supply

### Applications

- SONET/SDH: 622.08Mb/s
- Fiber channel: 531.25Mb/s

### Absolute Maximum Ratings

• Power supply	$V_{CC} - V_{EE}$	-0.3 to +7.0	V
• Storage temperature	Tstg	-65 to +150	°C
• Input voltage difference: $ V_D - \overline{V_D} $	Vdif	0.0 to +2.5	V
• Input voltage	$V_i$	-0.3 to $V_{CC}$	V
• Output current			
(Continuous)	$I_o$	0 to 50	mA
(Surge current)		0 to 100	mA

### Recommended Operating Conditions

• Supply voltage	$V_{CC} - V_{EE}$	$5.0 \pm 0.5$	V
• Operating temperature	$T_a$	-40 to +85	°C
• Termination resistor ( $Q/\overline{Q}$ )	$R_{T1}$	45 to 55	$\Omega$
• Termination resistor ( $SD/\overline{SD}$ )	$R_{T2}$	45 to 55	$\Omega$
• Termination voltage	$V_{CC} - V_{TT}$	1.8 to 2.2	V

### Structure

Bipolar silicon monolithic IC

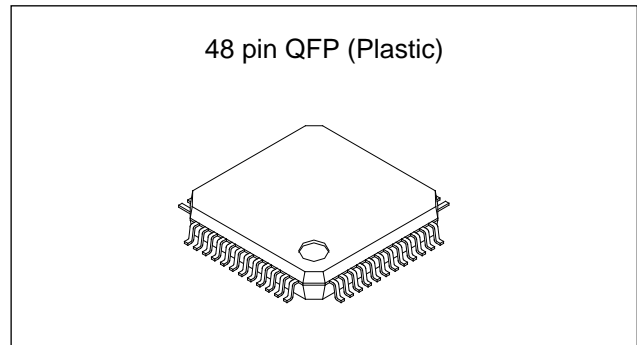

Sony reserves the right to change products and specifications without prior notice. This information does not convey any license by any implication or otherwise under any patents or other right. Application circuits shown, if any, are typical examples illustrating the operation of the devices. Sony cannot assume responsibility for any problems arising out of the use of these circuits.

Block Diagram and Pin Configuration

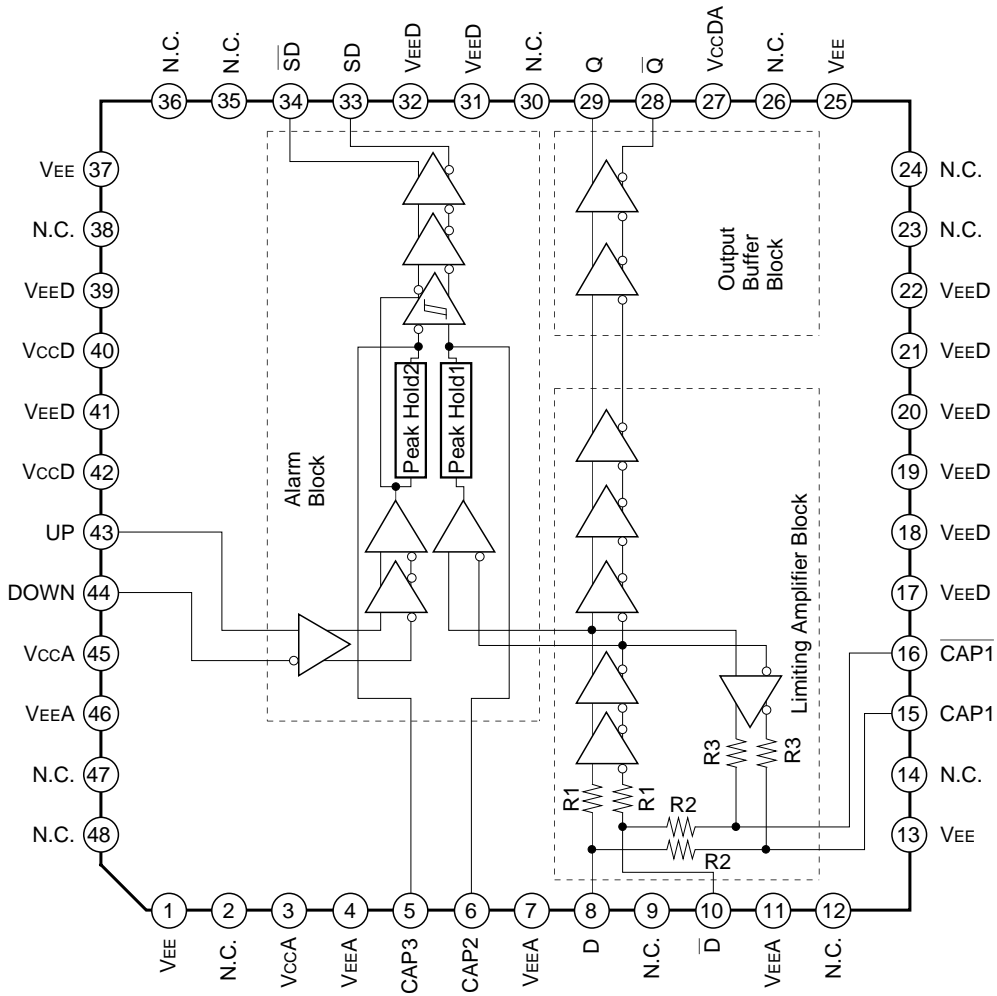

Pin Description

Pin No.	Symbol	Typical pin voltage (V)		Equivalent circuit	Description	
		DC	AC			
1	V <sub>EE</sub>	-5V			Negative power supply pin.	
2	N.C.				No connection.	
3	V <sub>CCA</sub>	0V			Positive power supply pin for analog block.	
4	V <sub>EEA</sub>	-5V			Negative power supply pin for analog block.	
5	CAP3	-1.8V			Capacitance connection pins for alarm block peak hold circuit. Connect each pin to V <sub>cc</sub> in 2000pF. CAP2 pin → Peak hold capacitance connection pin for the limiting amplifier signal  CAP3 pin → Peak hold capacitance connection pin for the alarm level setting block	
6	CAP2	-1.8V				
7	V <sub>EEA</sub>	-5V			Negative power supply pin for analog block.	
8	D	-1.3V	-0.9V to -1.7V		Limiting amplifier input pins Ensure that these inputs are AC-coupled.	
9	N.C.					Negative power supply pin for analog block.
10	$\bar{D}$	-1.3V				No connection.
11	V <sub>EEA</sub>	-5V				Negative power supply pin for analog block.
12	N.C.					No connection.
13	V <sub>EE</sub>	-5V				Negative power supply pin.
14	N.C.					No connection.
15	CAP1	-1.8V				Capacitance connection pins to determine the cut-off frequency for feedback block.
16	$\bar{CAP1}$	-1.8V				Capacitance connection pins to determine the cut-off frequency for feedback block.
17 to 22	V <sub>EED</sub>	-5V				Negative power supply pin for digital block.
23, 24	N.C.				No connection.	
25	V <sub>EE</sub>	-5V			Negative power supply pin.	

Pin No.	Symbol	Typical pin voltage (V)		Equivalent circuit	Description
		DC	AC		
26	N.C.				No connection.
27	VccDA	0V			Positive power supply pin for output buffer.
28	$\overline{Q}$		-0.9V to -1.7V		Data signal output pins. Terminate these pins in 50Ω at $V_{TT} = -2V$ .
29	Q		-0.9V to -1.7V		
30	N.C.				No connection.
31, 32	VEED	-5V			Negative power supply pin for digital block.
33	SD		-0.9V to -1.7V		Alarm signal output pins. Terminate these pins in 50Ω at $V_{TT} = -2V$ .
34	$\overline{SD}$		-0.9V to -1.7V		
35, 36	N.C.				No connection.
37	VEE	-5V			Negative power supply pin.
38	N.C.				No connection.
39	VEED	-5V			Negative power supply pin for digital block.
40	VccD	0V			Positive power supply pin for digital block.
41	VEED	-5V			Negative power supply pin for digital block.
42	VccD	0V			Positive power supply pin for digital block.

Pin No.	Symbol	Typical pin voltage (V)		Equivalent circuit	Description
		DC	AC		
43	UP	-4.7V			Resistor connection pins for alarm level setting. UP pin → When the resistance connected to this pin is increased, the alarm level becomes higher. DOWN pin → Normally connect this pin to VEE.
44	DOWN	-5V			
45	V <sub>CC</sub> A	0V			Positive power supply pin for analog block.
46	V <sub>EE</sub> A	-5V			Negative power supply pin for analog block.
47, 48	N.C.				No connection.

## Electrical Characteristics

- **DC characteristics** ( $V_{CC} = V_{CCA} = 0V$ ,  $V_{EED} = V_{EEA} = V_{EE} = -5V \pm 10\%$ ,  $T_a = -40^\circ\text{C}$  to  $+85^\circ\text{C}$ ,  $R_T = 50\Omega$ ,  $V_{TT} = -2V$ )

Item	Symbol	Conditions	Min.	Typ.	Max.	Unit
Supply current	$I_{EE}$		-93	-59		mA
$Q/\bar{Q}$ High output voltage	$V_{OH}$	$T_a = 0$ to $85^\circ\text{C}$	-1.03	-0.95	-0.88	V
$Q/\bar{Q}$ Low output voltage	$V_{OL}$		-1.81	-1.70	-1.62	
$SD/\bar{SD}$ High output voltage	$V_{OHS}$		-1.25	-0.95	-0.70	
$SD/\bar{SD}$ Low output voltage	$V_{OLS}$		-1.95	-1.76	-1.57	
Input offset voltage	$V_{OFF}$			70		$\mu\text{V}$
$D/\bar{D}$ input resistance	$R_{in}$		0.75	1.0	1.25	$k\Omega$

- **AC characteristics** ( $V_{CC} = V_{CCA} = 0V$ ,  $V_{EED} = V_{EEA} = V_{EE} = -5V \pm 10\%$ ,  $T_a = -40^\circ\text{C}$  to  $+85^\circ\text{C}$ ,  $R_T = 50\Omega$ ,  $V_{TT} = -2V$ )

Item	Symbol	Conditions	Min.	Typ.	Max.	Unit
Maximum input data rate	B		622.08			Mbps
Maximum input voltage	$V_{MAX}$	Single-ended input voltage at D	1000			mVpp
Limiting amplifier gain	GL	IC internal amplitude 400mVpp	66			dB
$Q/\bar{Q}$ rise time	$T_{TLH}$	20% to 80%		240	450	ps
$Q/\bar{Q}$ fall time	$T_{THL}$			240	450	
Identification maximum voltage amplitude of alarm level	$V_{MIN}$		20			mVpp
Hysteresis width	Hys	Electrically tested	4	6	8	dB
Alarm response assert time	$T_{AS}$	Low $\rightarrow$ High *1 (SD)	0		100	$\mu\text{s}$
Alarm response deassert time	$T_{DAS}$	High $\rightarrow$ Low *2 (SD)	2.5		100	

\*1 CAP2, CAP3 pin capacitance = 2000pF,  $R_{EX} = 400\Omega$ ,  $V_{in} = 20\text{mVpp}$  (single ended)

\*2 CAP2, CAP3 pin capacitance = 2000pF,  $R_{EX} = 400\Omega$ ,  $V_{in} = 60\text{mVpp}$  (single ended)

DC Electrical Characteristics Measurement Circuit

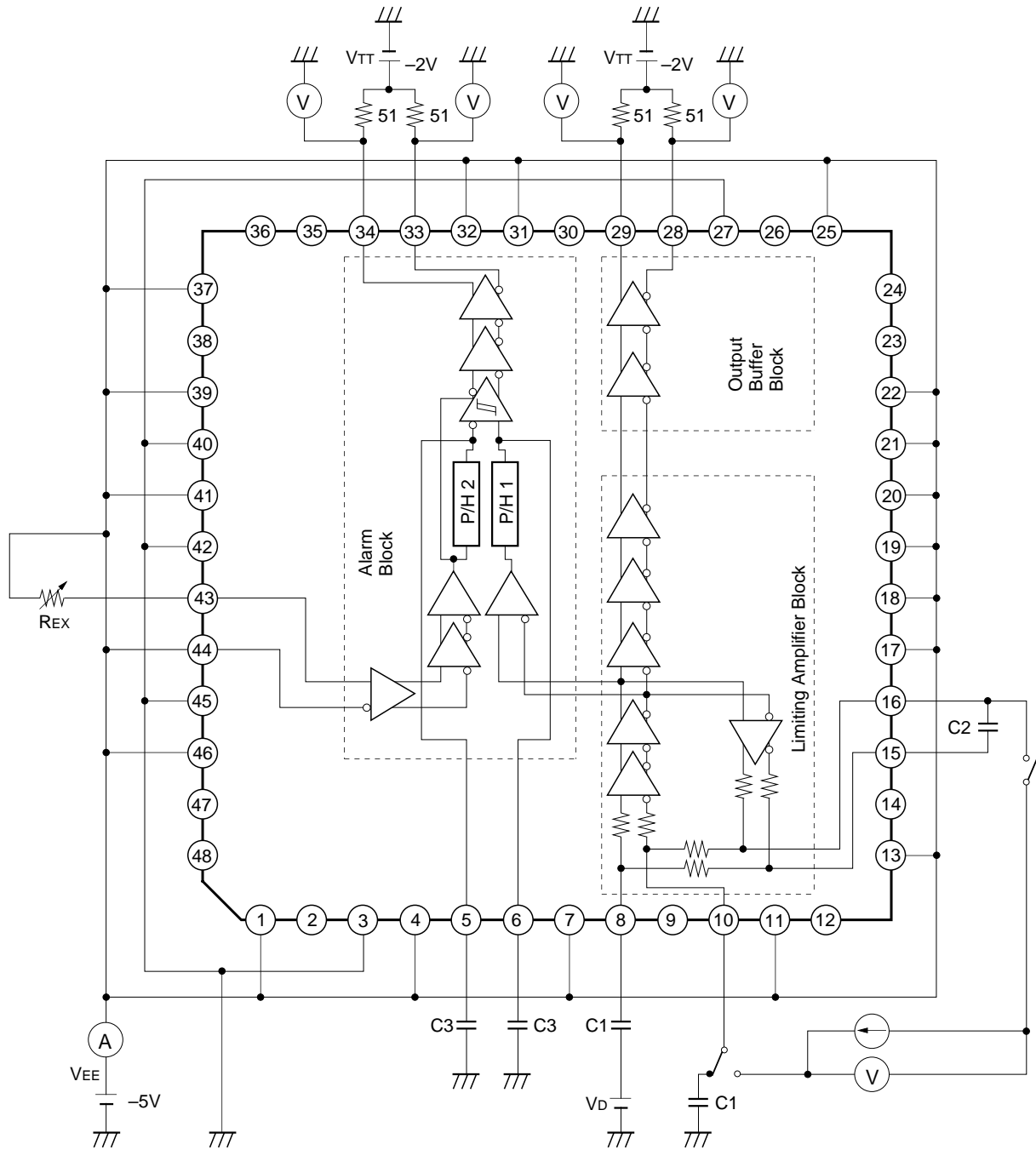

AC Electrical Characteristics Measurement Circuit

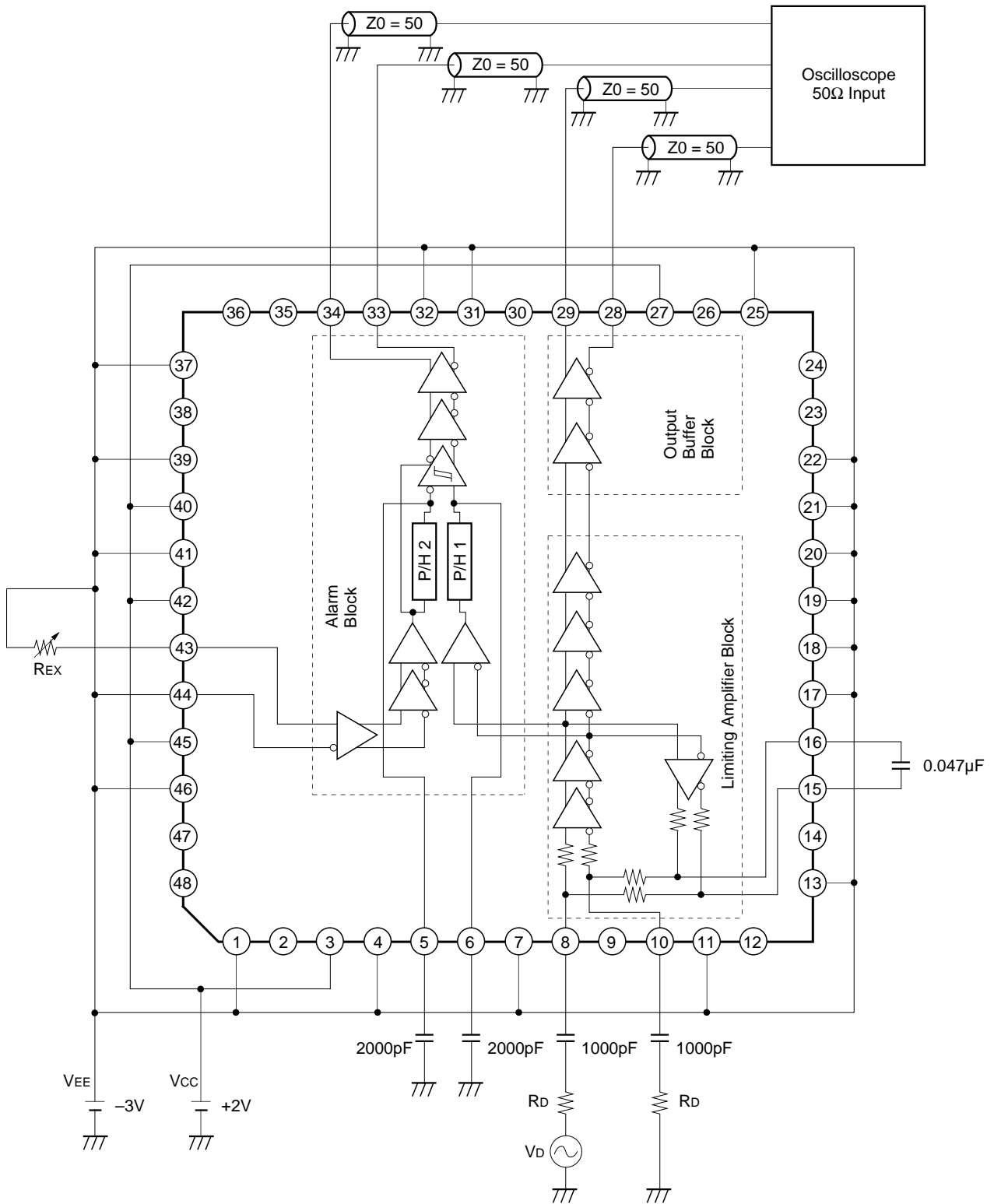

Application Circuit

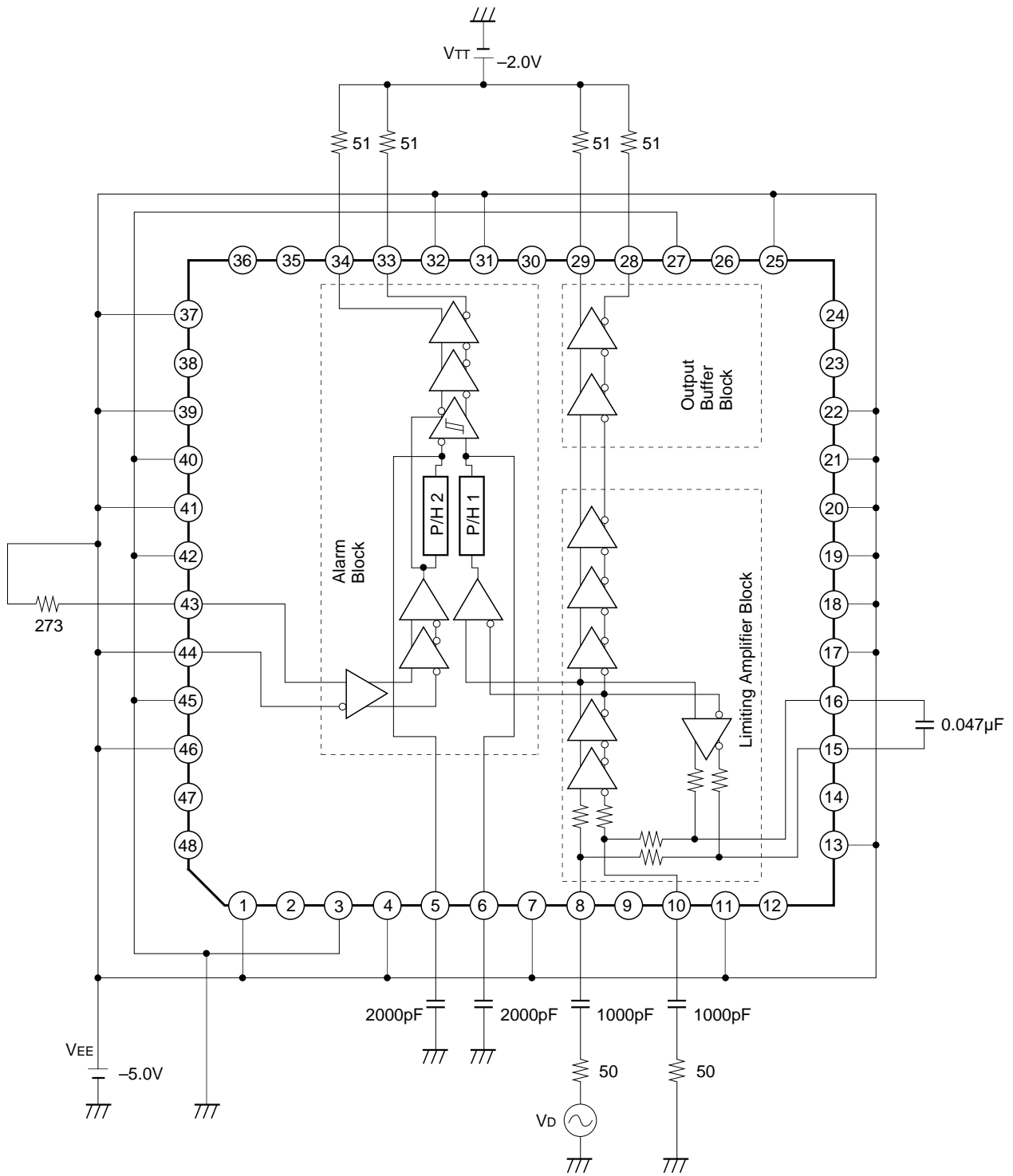

Application circuits shown are typical examples illustrating the operation of the devices. Sony cannot assume responsibility for any problems arising out of the use of these circuits or for any infringement of third party patent and other right due to same.

Notes on Operation

1. Limiting amplifier block

The limiting amplifier block is equipped with the auto-offset canceller circuit. When external capacitors C1 and C2 are connected as shown in Fig. 1, the DC bias is set automatically in this block. External capacitor C1 and IC internal resistor R1 determine the low input cut-off frequency  $f_2$ , as shown in Fig. 2. Similarly, external capacitor C2 and internal resistor R2 determine the high cut-off frequency  $f_1$  for DC bias feedback. Since peaking characteristics may occur in the low frequency area of the amplifier gain characteristics depending on the  $f_1/f_2$  combination, set the C1 and C2 values so as to avoid the occurrence of peaking characteristics. The typical values of R1, R2, C1 and C2 are as indicated below. When a single-ended input is used, provide AC grounding by connecting Pin 10 to a capacitor which has the same capacitance as capacitor C1. R<sub>D</sub> is the resistor for impedance matching. The same level of output impedance as for the signal source should be applied to Pin 10.

R1 (internal) : 1k $\Omega$	} f <sub>2</sub> : 160kHz	R2 (internal) : 7.5k $\Omega$	} f <sub>1</sub> : 450Hz
C1 (external) : 1000pF		C2 (external) : 0.047 $\mu$ F	

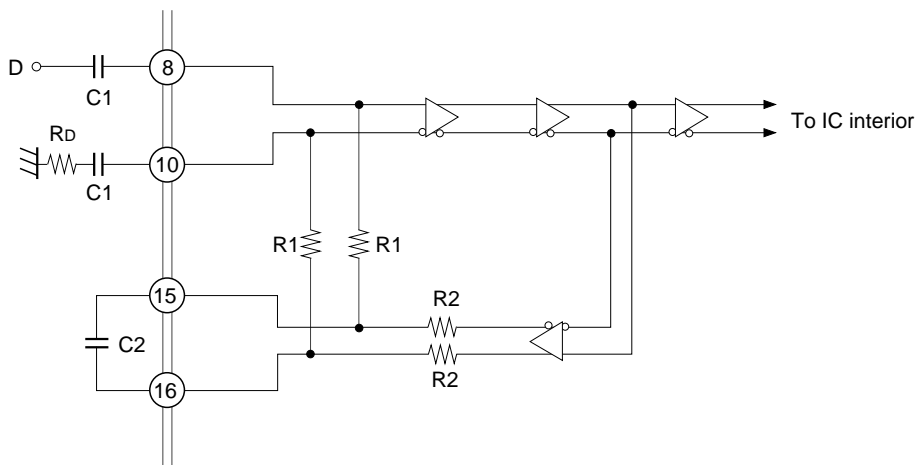

Fig. 1

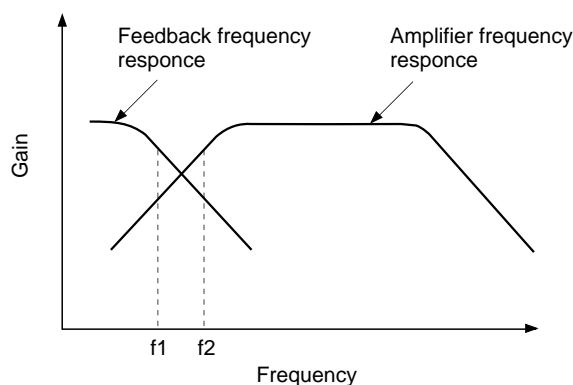

Fig. 2

2. Alarm block

As shown in Fig. 3, the alarm block requires external resistor  $R_{EX1}$  for alarm level setting and peak hold capacitor  $C3$ . When the resistance value provided for resistor  $R_{EX1}$  is increased, the alarm setting level rises. When the resistance value provided for  $R_{EX2}$  is increased, the alarm setting level lowers. However, the voltage of Pin 43 should always be higher than that of Pin 44. Normally, short-circuit Pin 44 to  $V_{EE}$  ( $R_{EX2} = 0$ ). See Fig. 5 for the alarm setting level. In the relationship between the alarm setting level and hysteresis width, the hysteresis width is designed to maintain a constant gain (design target value: 6dB) as shown in Fig. 4. External capacitors  $C3$  are used for input signal and alarm level peak hold capacitance. The  $C3$  capacitance value should be set so as to obtain desired assert time and deassert time settings for the alarm signal. The deassert time becomes smaller by connecting resistor  $R10$  between  $V_{EE}$  and Pin 5 and resistor  $R11$  between  $V_{EE}$  and Pin 6. The  $R_{EX1}$  and  $C3$  typical values are indicated below. (A capacitance of approximately 10pF is built in Pins 5 and 6 respectively.)

$R_{EX1}$ : 273Ω ( $V_{DAS} = 3mV_{pp}$ )  
 $C3$ : 2000pF

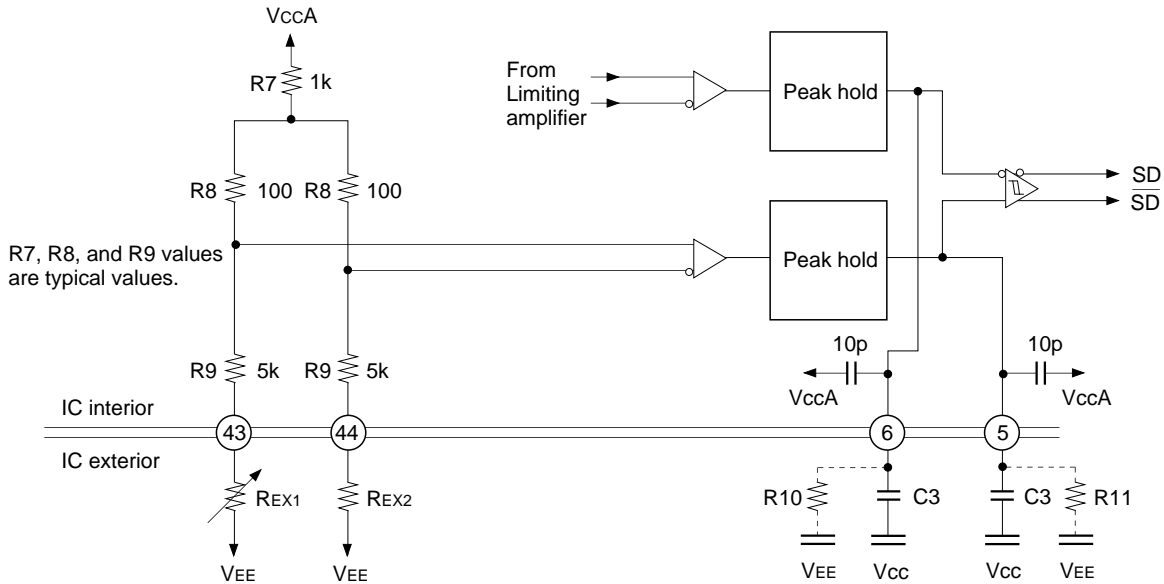

Fig. 3

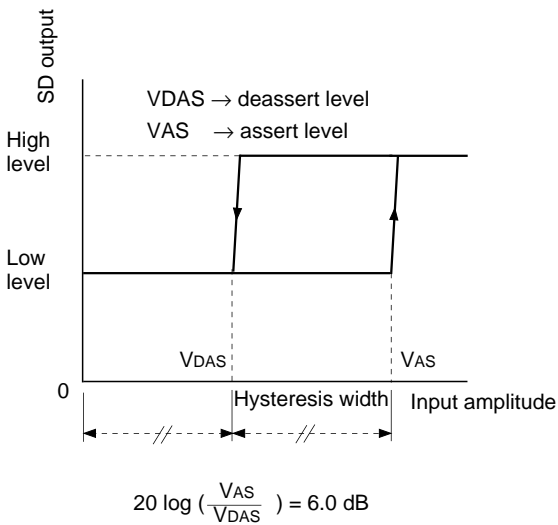

Fig. 4

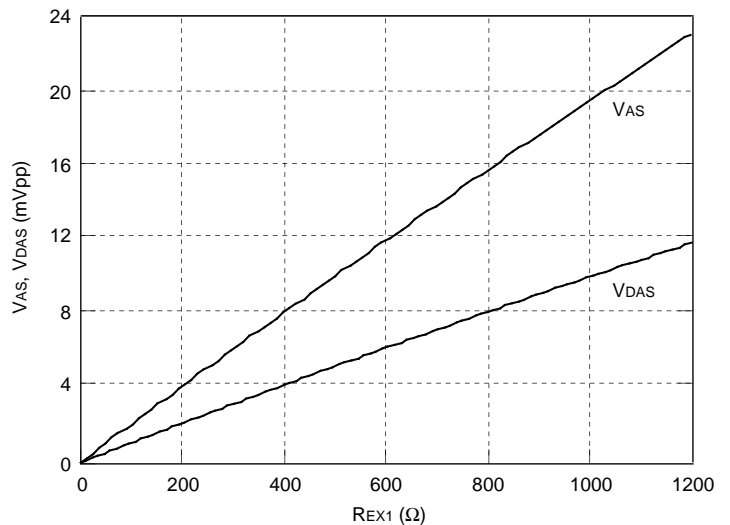
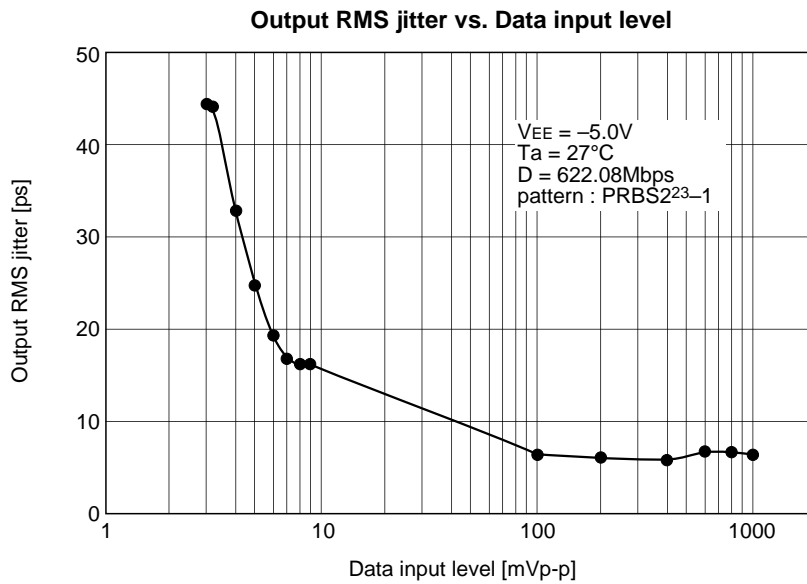
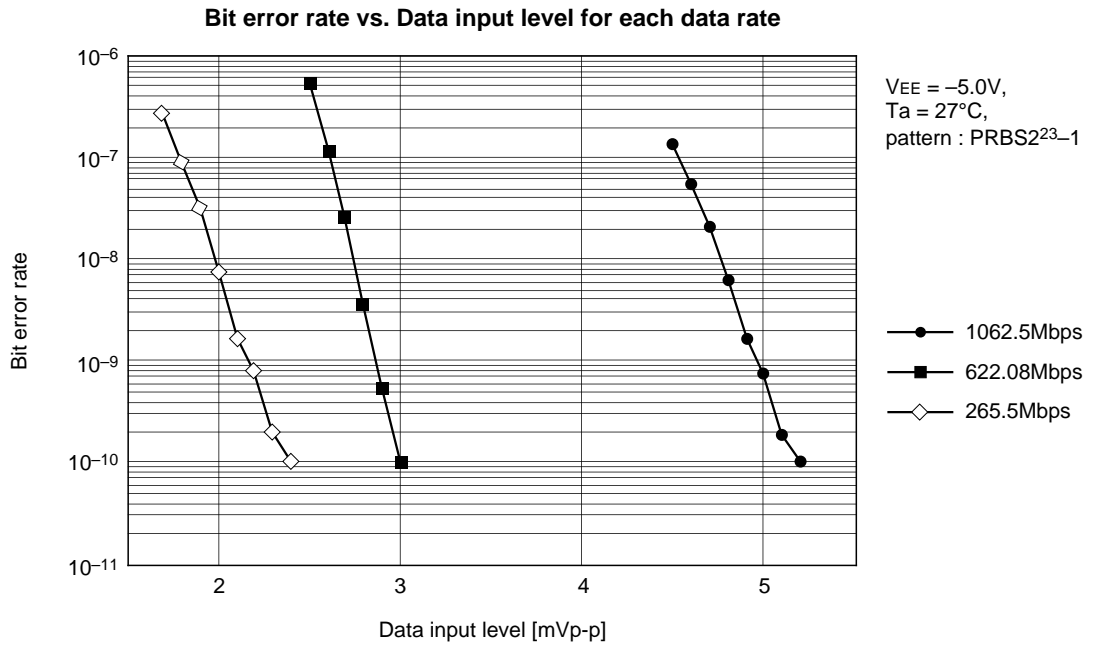

Fig. 5

Example of Representative Characteristics



$V_{EE} = -5.0V$   
 $T_a = 27^{\circ}C$   
 $D = 265.5Mbps$   
 pattern = PRBS $2^{23}-1$

Y Axis = 300mV/div  
 X Axis = 1300ps/div

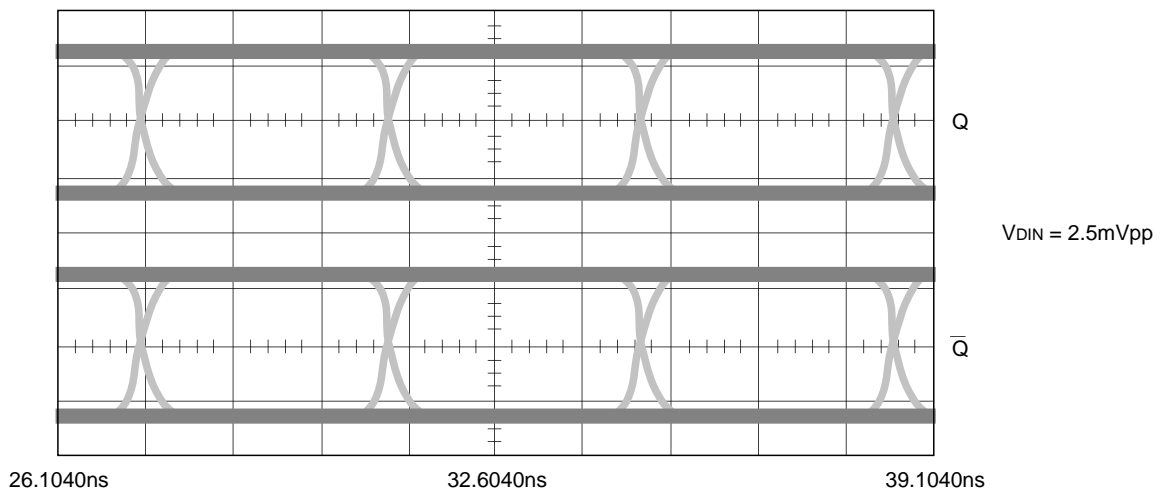
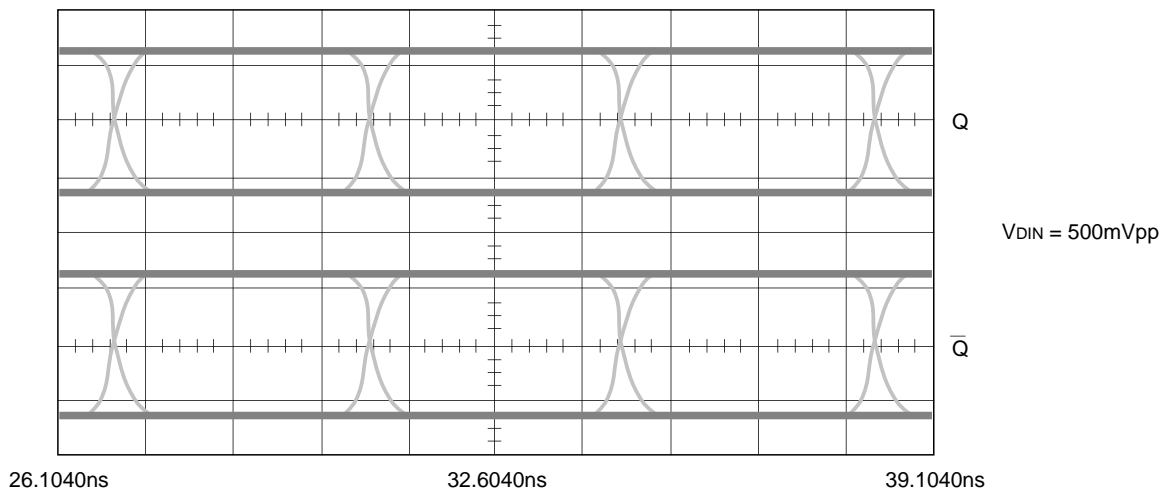
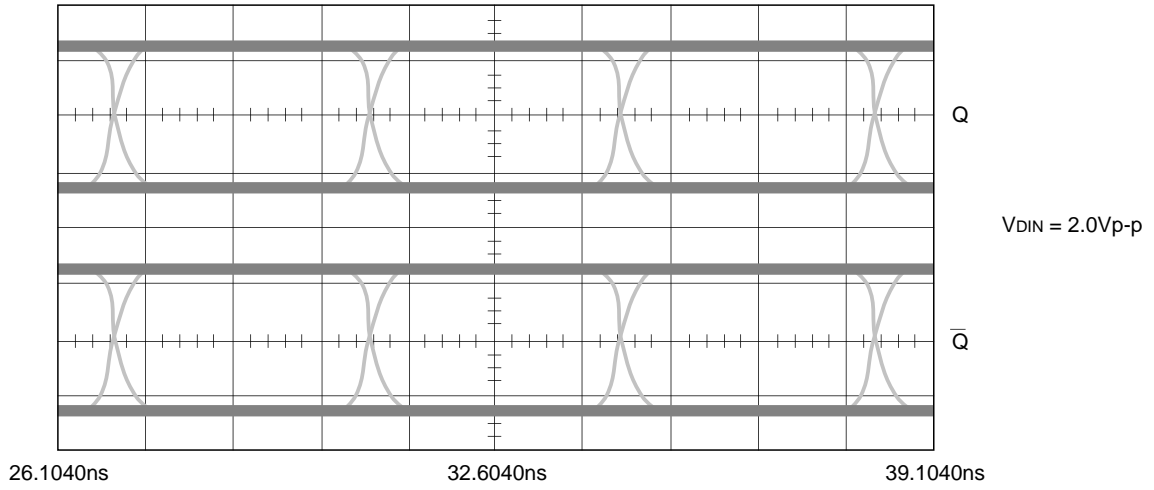

$V_{EE} = -5.0V$                       Y Axis = 300mV/div  
 $T_a = 27^{\circ}C$                          X Axis = 500ps/div  
 $D = 622.08Mbps$   
 pattern = PRBS $2^{23}-1$

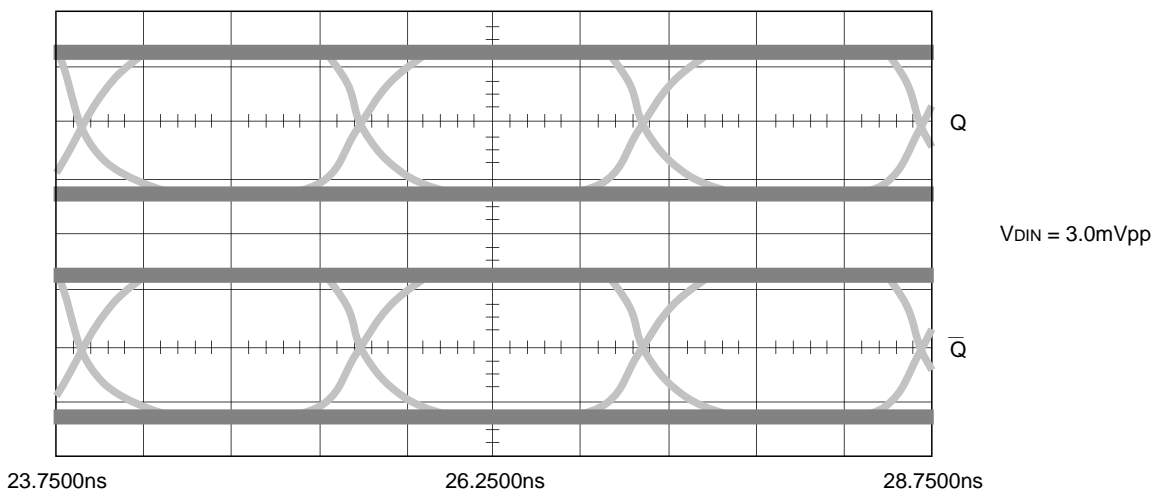
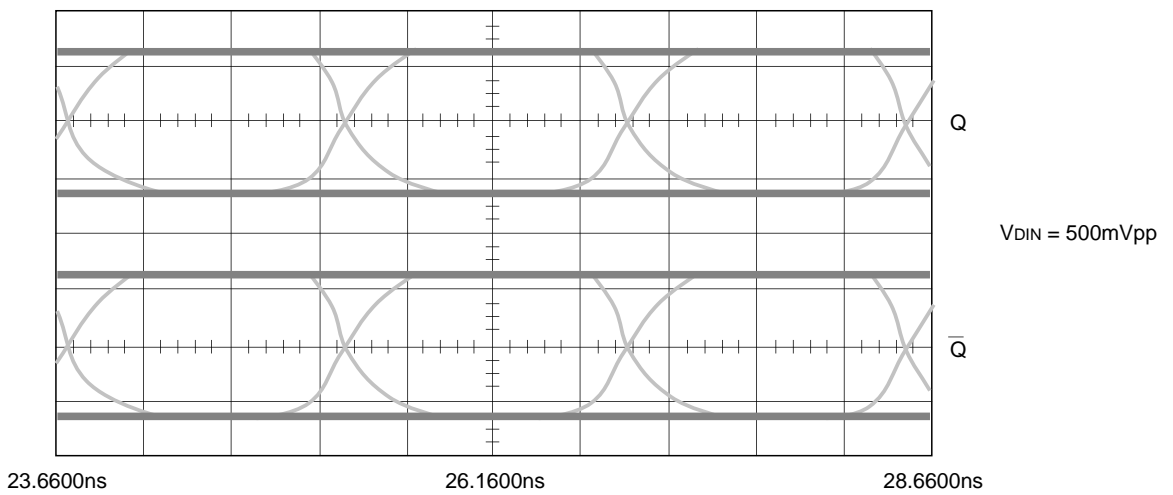
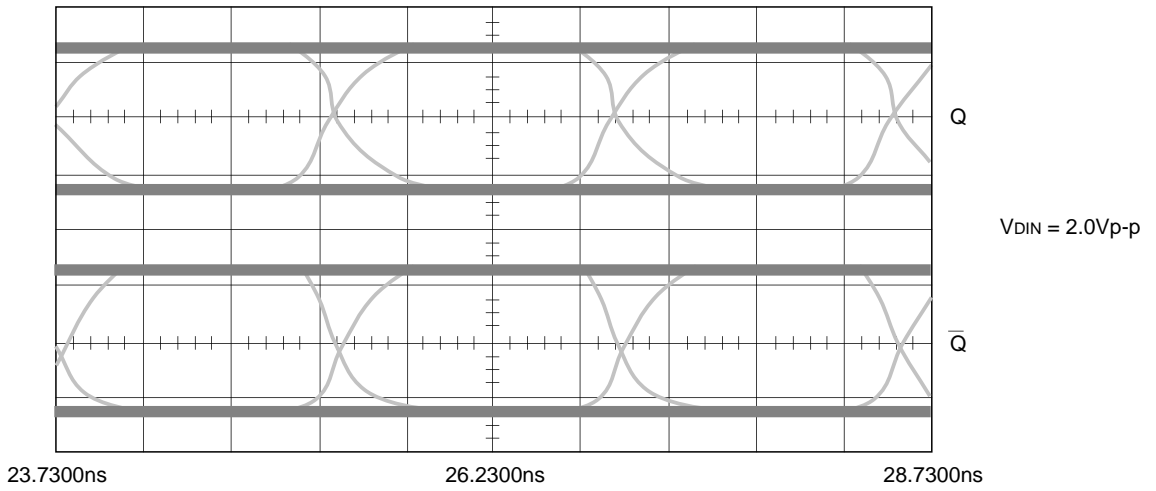

$V_{EE} = -5.0V$   
 $T_a = 27^{\circ}C$   
 $D = 1062.5Mbps$   
pattern = PRBS2<sup>23</sup>-1

Y Axis = 300mV/div  
X Axis = 300ps/div

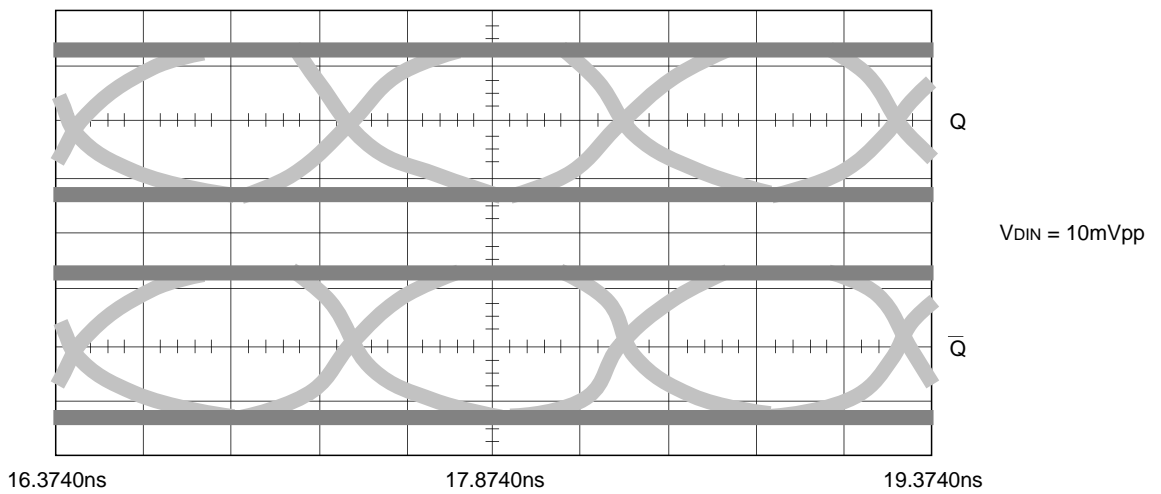
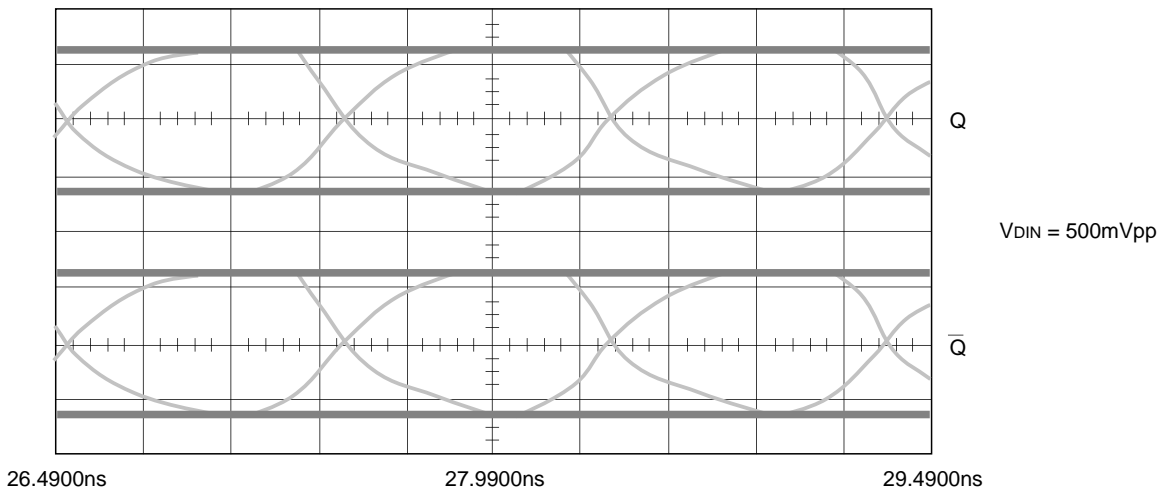
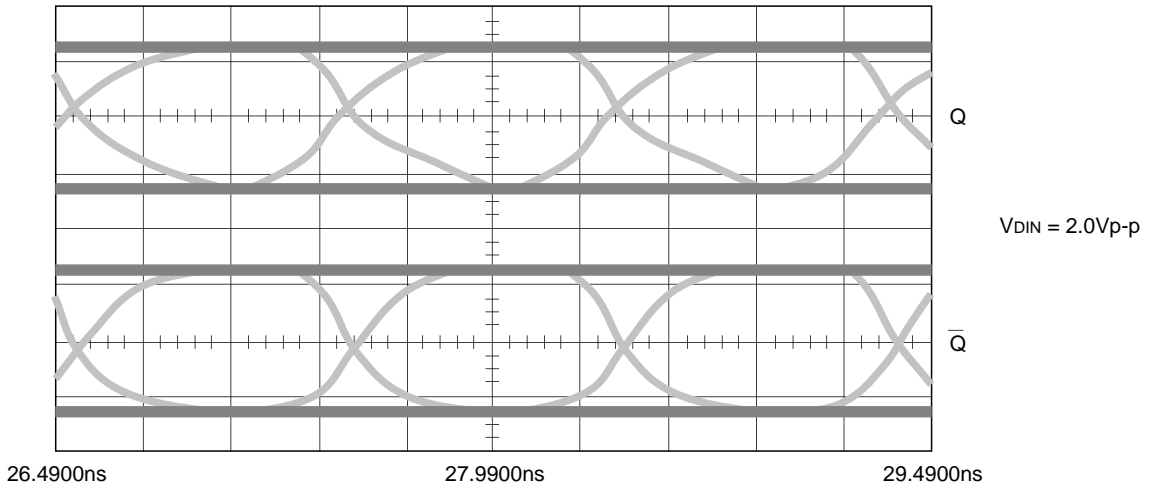

Package Outline Unit: mm

48PIN QFP (PLASTIC)

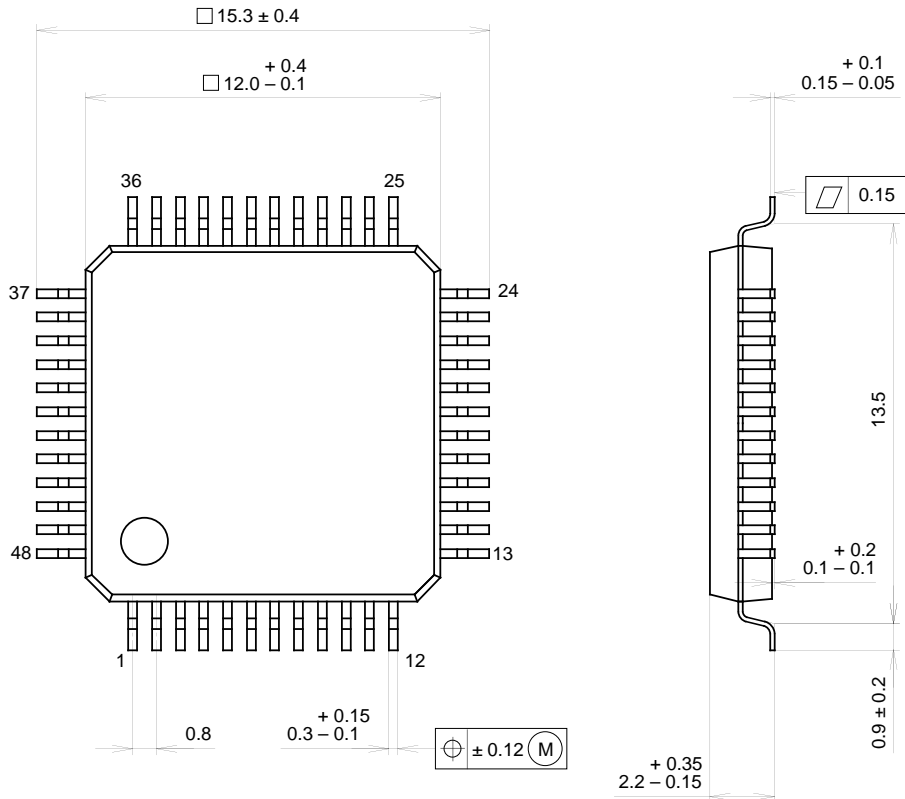

PACKAGE STRUCTURE

SONY CODE	QFP-48P-L04
EIAJ CODE	*QFP048-P-1212-B
JEDEC CODE	—

PACKAGE MATERIAL	EPOXY RESIN
LEAD TREATMENT	SOLDER / PALLADIUM PLATING
LEAD MATERIAL	COPPER / 42 ALLOY
PACKAGE WEIGHT	0.7g



LittleDiode supplies new, hard to find or obsolete electronic components and semiconductors all over the world.

With over two million different components listed you are sure to find the part you need.

Feel free to visit us today at our online store:

[LittleDiode.com](http://LittleDiode.com)

Looking forward to providing you with the best possible service.