

VGA/SVGA/XGA 24-bit Receiver

Description

CXB1456R is the 1 chip deserializer for VGA/SVGA/XGA 24-bit color digital RGB, and meet to the Gigabit Video Interface specification.

Features

- 1 chip receiver for serial transmission of 24-bit color VGA/SVGA/XGA picture
- On chip PLL circuit for data and clock recovery
- On chip panel mode automatically selectable circuit
- TTL compatible I/O
- Support 1 pixel/shiftclock mode with 1 chip and 2 pixel/shiftclock mode with 2 chip
- +3.3V single power supply
- Low power consumption
- 64pin plastic LQFP package with body size 10mm × 10mm

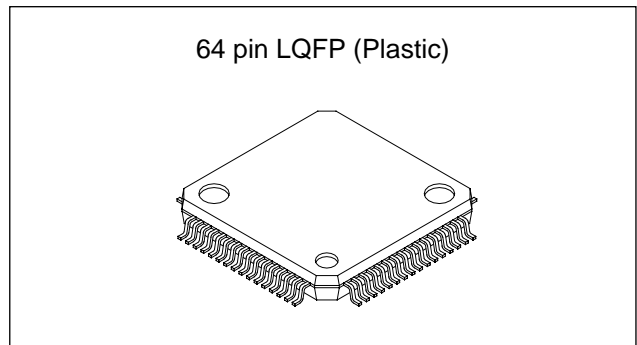

Absolute Maximum Ratings

• Supply voltage	Vcc	4.2	V
• Storage temperature	Tstg	-65 to +150	°C
• Allowable power dissipation	PD	650	mW

Application

Gigabit video interface

Recommended Operating Condition

• Supply voltage		3.3 ± 0.3	V
• Operating temperature	Topr	0 to +80	°C

Structure

Bi-CMOS IC

Block Diagram & Pin out

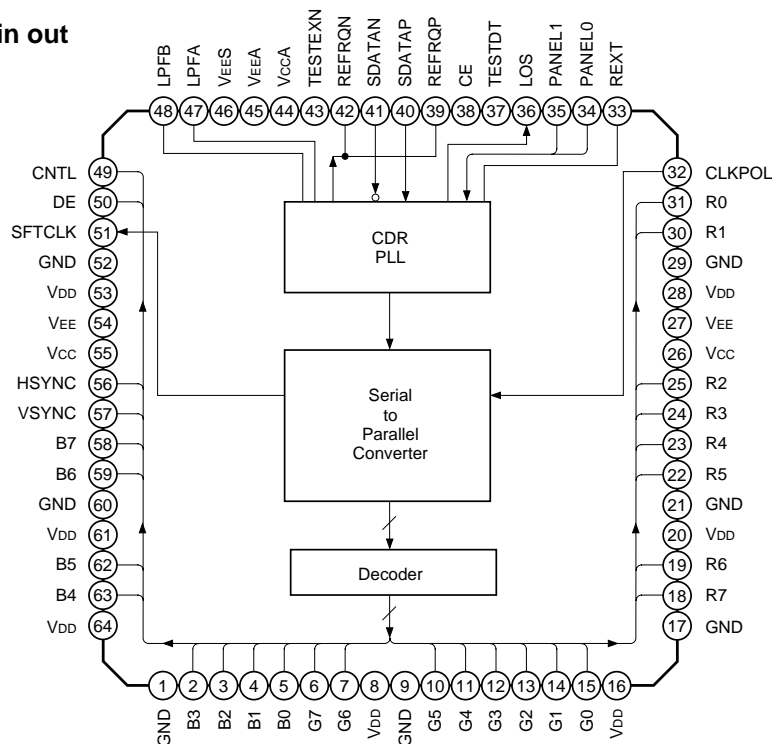

Fig. 1. Block Diagram & Pin out

Sony reserves the right to change products and specifications without prior notice. This information does not convey any license by any implication or otherwise under any patents or other right. Application circuits shown, if any, are typical examples illustrating the operation of the devices. Sony cannot assume responsibility for any problems arising out of the use of these circuits.

Pin List

Table 1. Power/Ground

Pin name	Pin number	Descriptions
V <sub>DD</sub>	8, 16, 20, 28, 53, 61, 64	MOS power supply, should be connected to 3.3V ± 0.3V
GND	1, 9, 17, 21, 29, 52, 60	MOS ground, connected to 0V
V <sub>CC</sub>	26, 55	ECL power supply, connected to 3.3V ± 0.3V
V <sub>EE</sub>	27, 54	ECL ground, connected to 0V
V <sub>CCA</sub>	44	Analog power supply, connected to 3.3V ± 0.3V
V <sub>EEA</sub>	45	Analog ground, connected to 0V
V <sub>EEs</sub>	46	Substrate GND, connected to 0V

Table 2. Digital Signals

Pin name	Pin number	Type	Descriptions	Equivalent circuit
SFTCLK	51	TTL out	Shift clock, for the data fetch at falling or rising edge	
RED (7 to 0)	18, 19, 22, 23, 24, 25, 30, 31	TTL out	Pixel data	
GRN (7 to 0)	6, 7, 10, 11, 12, 13, 14, 15			
BLU (7 to 0)	58, 59, 62, 63, 2, 3, 4, 5			
HSYNC	56	TTL out	Hsync data	
VSYNC	57	TTL out	Vsync data	
CNTL	49	TTL out	Control data	
DE	50	TTL out	Display enable data	
LOS	36	TTL out	Los of signal	
PANEL (1, 0)	35, 34	TTL in	Panel mode select switch	
CLKPOL	32	TTL in	Trigger edge select switch	
CE	38	TTL in	Chip enable	
TESTEXN TESTDT	43, 37	TTL in	Reversed for TEST under fabrication	

Table 2. Digital Signals (Cont.)

Pin name	Pin number	Type	Descriptions	Equivalent circuit
SDATAP/N	40, 41	Rx	Serial input	
REFRQP/N	39, 42	Rx	Refclk request	

Table 3. Special

Pin name	Pin number	Descriptions	Equivalent circuit
REXT	33	External Register	
LPFA/B	47, 48	External loop filter	

## Electrical characteristics

Table 4. Absolute Maximum Rating

Description	Symbol	Min.	Typ.	Max.	Unit	Comments
Power supply voltage	V <sub>CC</sub>	-0.3		4.2	V	
TTL DC input voltage	V <sub>I_T</sub>	-0.5		4.6	V	
TTL output current (High)	I <sub>OH_T</sub>	-10		0	mA	
TTL output current (Low)	I <sub>OL_T</sub>	0		10	mA	
Serial input pin voltage	V <sub>sdin</sub>	-0.5		V <sub>CC</sub> + 0.5	V	
REFREQ output pin voltage	V <sub>RQout</sub>	0.5		V <sub>CC</sub> + 0.5	V	
Storage temperature	T <sub>stg</sub>	-65		150	°C	

Table 5. Recommended Operating Conditions

Description	Symbol	Min.	Typ.	Max.	Unit	Comments
Power supply voltage	V <sub>CC</sub>	3.0	3.3	3.6	V	
Ambient temperature	T <sub>a</sub>	0		80	°C	

Table 6. DC Characteristics (Under the recommended conditons. See Tab. 5)

Description	Symbol	Min.	Typ.	Max.	Unit	Conditions	
Input HIGH voltage (TTL)	V <sub>IH_T</sub>	2		V <sub>CC</sub>	V		
Input LOW voltage (TTL)	V <sub>IL_T</sub>	0		0.8	V		
Input HIGH current (TTL)	I <sub>IH_T</sub>			10	μA	V <sub>IN</sub> = V <sub>CC</sub>	
Input LOW current (TTL)	I <sub>IL_T</sub>	-10			μA	V <sub>IN</sub> = 0	
Output HIGH voltage (TTL)	V <sub>OH_T</sub>	2.4			V	I <sub>OH</sub> = -3mA	
Output LOW voltage (TTL)	V <sub>OL_T</sub>			0.4	V	I <sub>OL</sub> = 3mA	
Output HIGH current (REFREQ)	I <sub>OH_RQ</sub>	-0.1	0	+0.1	mA	See Fig. 3, 4 R <sub>EXT</sub> = 5.6kΩ	
Output LOW current (REFREQ)	I <sub>OL_RQ</sub>	7.8		11	mA		
Input dynamic range (SDATA)	V <sub>IM_SD</sub>	V <sub>CC</sub> - 0.4		V <sub>CC</sub> + 0.2	V	Common mode voltage	
Input dynamic range (SDATA)	V <sub>ID_SD</sub>	-0.5		+0.5	V	Differential voltage	
Supply current	Worst Case	I <sub>CC</sub>		138	173	mA	C <sub>L</sub> = 8pF, f = 65MHz See Fig. 9, 10
	16 Grayscale			77	104	mA	

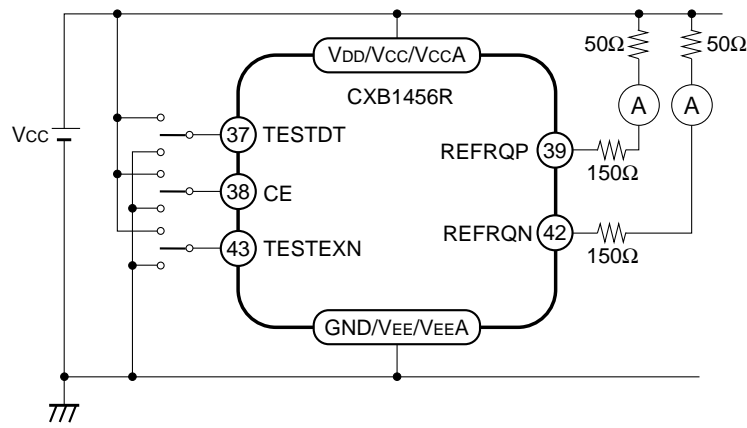

Fig. 3.  $I_{OH\_RQ}$  and  $I_{OL\_RQ}$  DC measurement

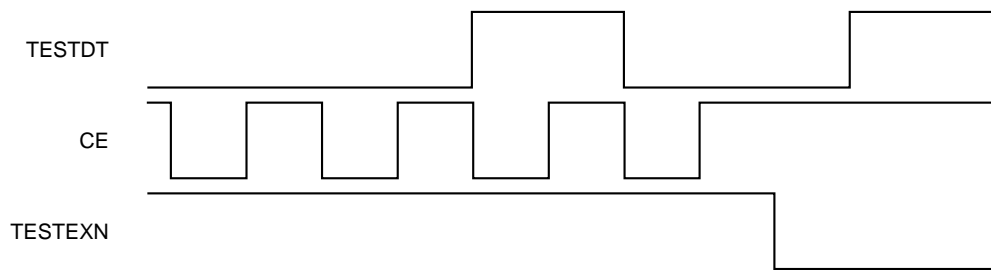
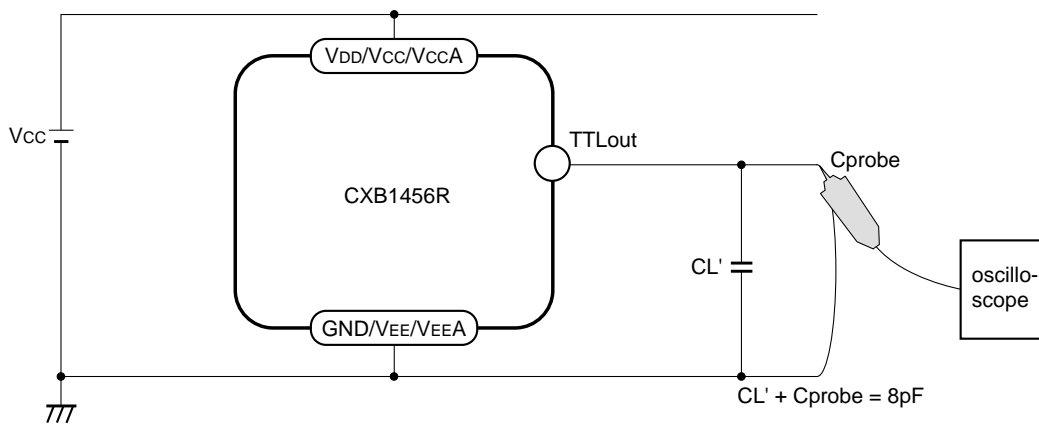

Fig. 4.  $I_{OH\_RQ}$  and  $I_{OL\_RQ}$  DC measurement setting

**Table 7. AC Characteristics (Under the recommended conditons. See Tab. 5)**

Description	Symbol	Min.	Typ.	Max.	Unit	Conditions
Minimum SFTCLK frequency	Fsftclk	65.0		25.0	MHz	
Maximum SFTCLK frequency					MHz	
SFTCLK duty factor	Dsftclk	35		65	%	Vth = 1.4V, CL = 8pF
Pixel/Sync/Cnt/DE setup to SFTCLK	Tsetup	17 9 4.5			ns ns ns	Vth = 1.4V, CL = 8pF 25MHz 40MHz 65MHz
Pixel/Sync/Cnt/DE hold to SFTCLK	Thold	16 9 4.5			ns ns ns	Vth = 1.4V, CL = 8pF 25MHz 40MHz 65MHz
SFTCLK rise time	Torc			5	ns	0.8V to 2.0V, CL = 8pF
SFTCLK fall time	Tofc			3	ns	2.0V to 0.8V, CL = 8pF
Pixel/Sync/Cnt/DE rise time	Tord			5	ns	0.8V to 2.0V, CL = 8pF
Pixel/Sync/Cnt/DE fall time	Tord			3	ns	2.0V to 0.8V, CL = 8pF
CLOCK mode assert time	TAclk		0.5		μs	
CLOCK mode deassert time	TDclk		20		μs	
LOS signal assert time	TAlos		0.5		μs	
LOS signal deassert time	TDlos		0.15		μs	



**Fig. 5. Pixel/Sync/Cnt/DE waveform measurement**

Timing Chart

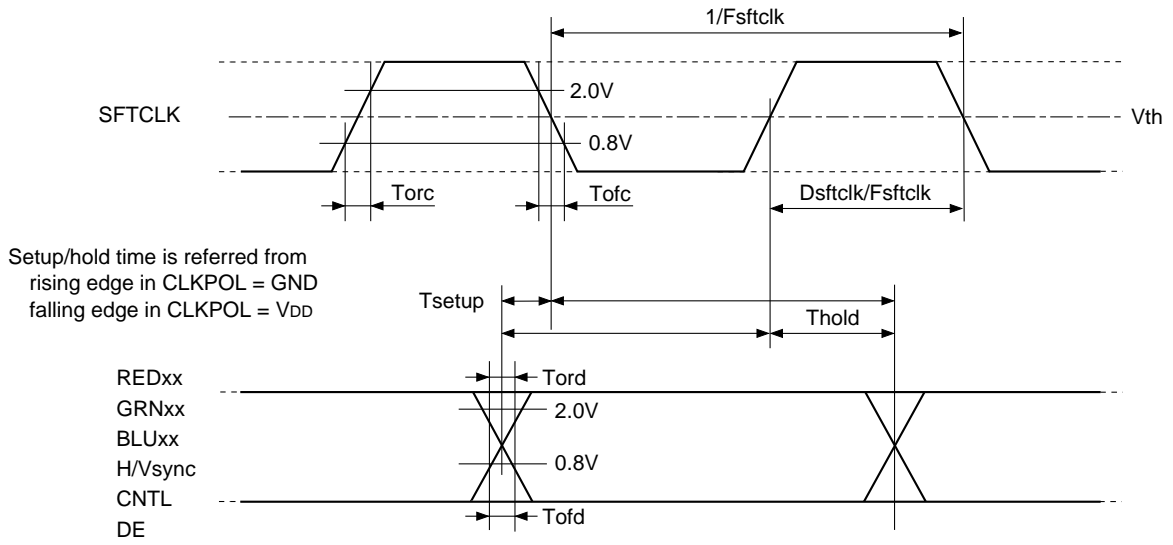

Fig. 6. TTL output timing

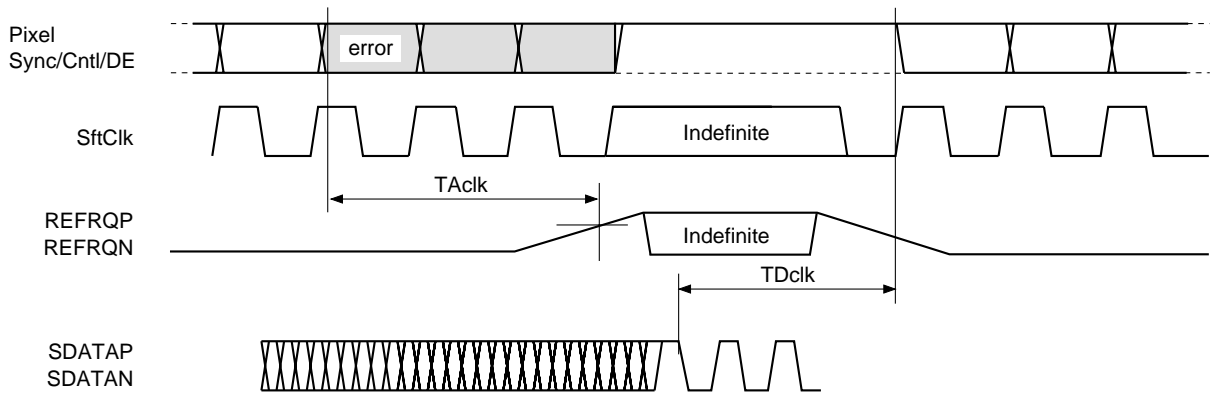

Fig. 7. Refclk request timing

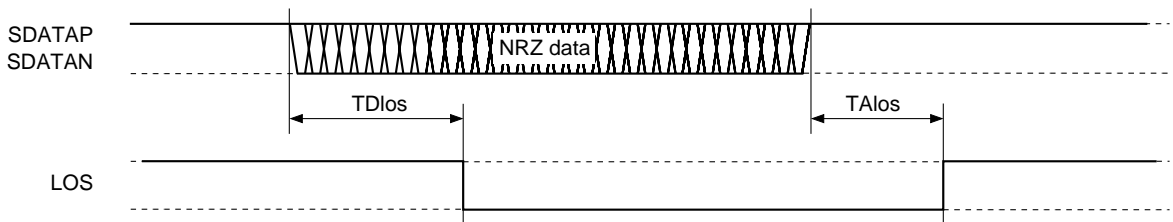

Fig. 8. Idle mode timing

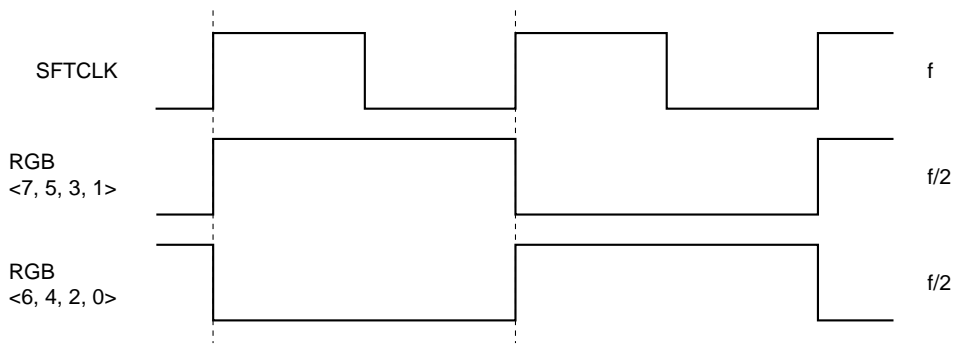

Fig. 9. Worst case test pattern

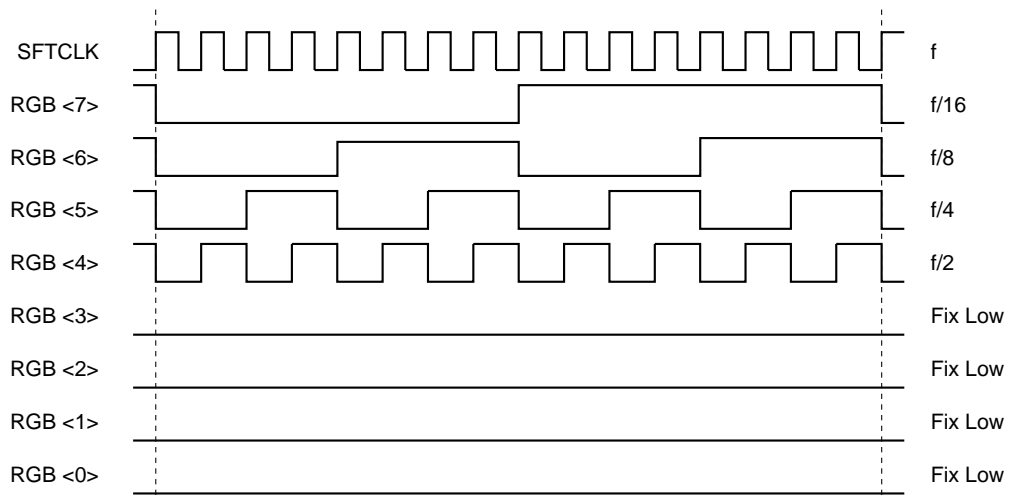

Fig. 10. 16 Grayscale test pattern

**CLKPOL Pin Control**

The CLKPOL pin is used to select the SFTCLK trigger edge. (See Table 8.)

The CLKPOL pin is open High-impedance TTL input, and this should not be left open for use. (See Fig. 12. Recommended application circuit.)

**Table 8. SFTCLK Polarity**

CLKPOL	Receiver operation trigger
L	Rising edge
H	Falling edge

**PANEL1 and 0 Pin Control**

The PANEL1 and 0 pins are used to select the panel mode. (See Table 9.)

For the normal use, the all frequencies of SFTCLK (25MHz to 65MHz) can be covered by fixing both PANEL1 and 0 to High.

The PANEL1 and 0 pins are open High-impedance TTL inputs, and they should not be left open for use. (See Fig. 12. Recommended application circuit.)

**Table 9. Panel Mode**

PANEL1	PANEL0	Supporting panel size	Shift Clock	Serial rate
L	L	VGA (640 × 480)	25MHz	750Mbps
L	H	SVGA (800 × 600)	40MHz	1200Mbps
H	L	XGA (1024 × 768)	65MHz	1950Mbps
H	H	VGA to XGA	25MHz to 65MHz	750Mbps to 1950Mbps

**CE Pin Control**

The CE pin is used to select the standby mode. (See Table 10.)

The CE pin is open High-impedance TTL input, and this should not be left open for use. (See Fig. 12. Recommended application circuit.)

**Table 10**

CE	Operation mode
L	Standby mode, all TTL outputs fixed to Low (excluding LOS)
H	Normal mode

**Test Pin Control**

The TESTEXN and TESTDT pins are for test only. Select normal mode. (See Table 11.)

The TESTEXN and TESTDT pins are open High-impedance TTL inputs, and they should not be left open for use.

**Table 11. Test mode**

TESTEXN	TESTDT	Operation mode
L	X	Test mode
H	X	Normal mode

**LOS Pin Output**

The LOS pin shows the absence of proper level of SDATA signal. The LOS pin is High when the connector is disconnected or the transmitter is idle.

The LOS pin is TTL output.

**Applications**

CXB1456R GVIF receiver is applied to the digital RGB signal transmission for  
 P/C with LCD monitor  
 Video on demand system  
 Monitoring system  
 Graphical controller  
 Projector  
 Digital TV monitor  
 Car navigation system  
 with GVIF transmitter, CXB1455R.

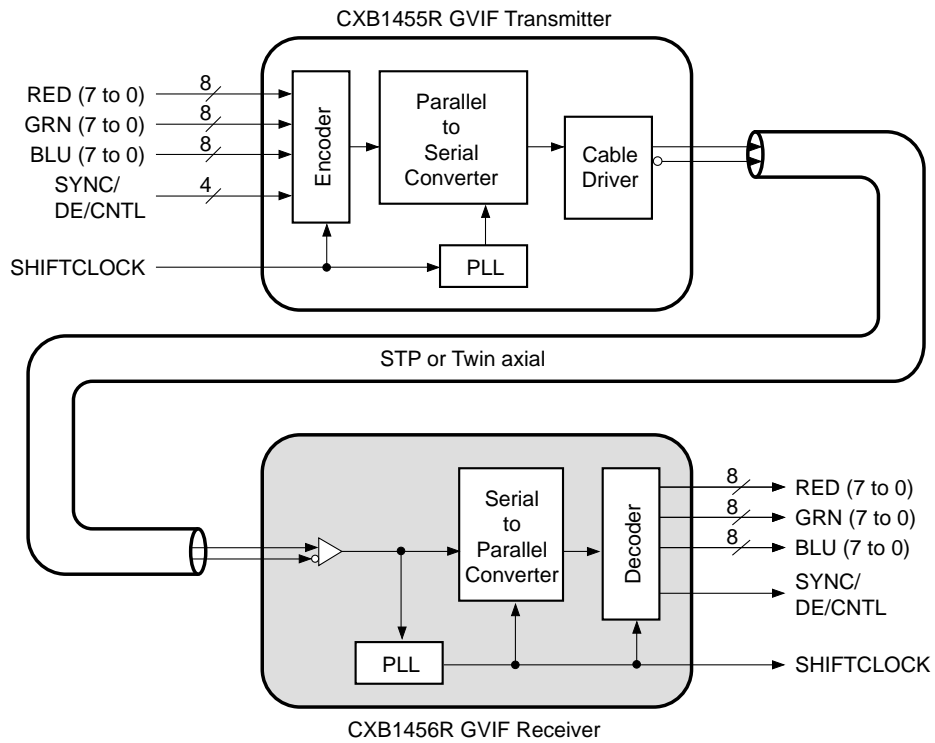

**Fig. 11. Block Diagram of GVIF transceiver chip set**

Application Circuit

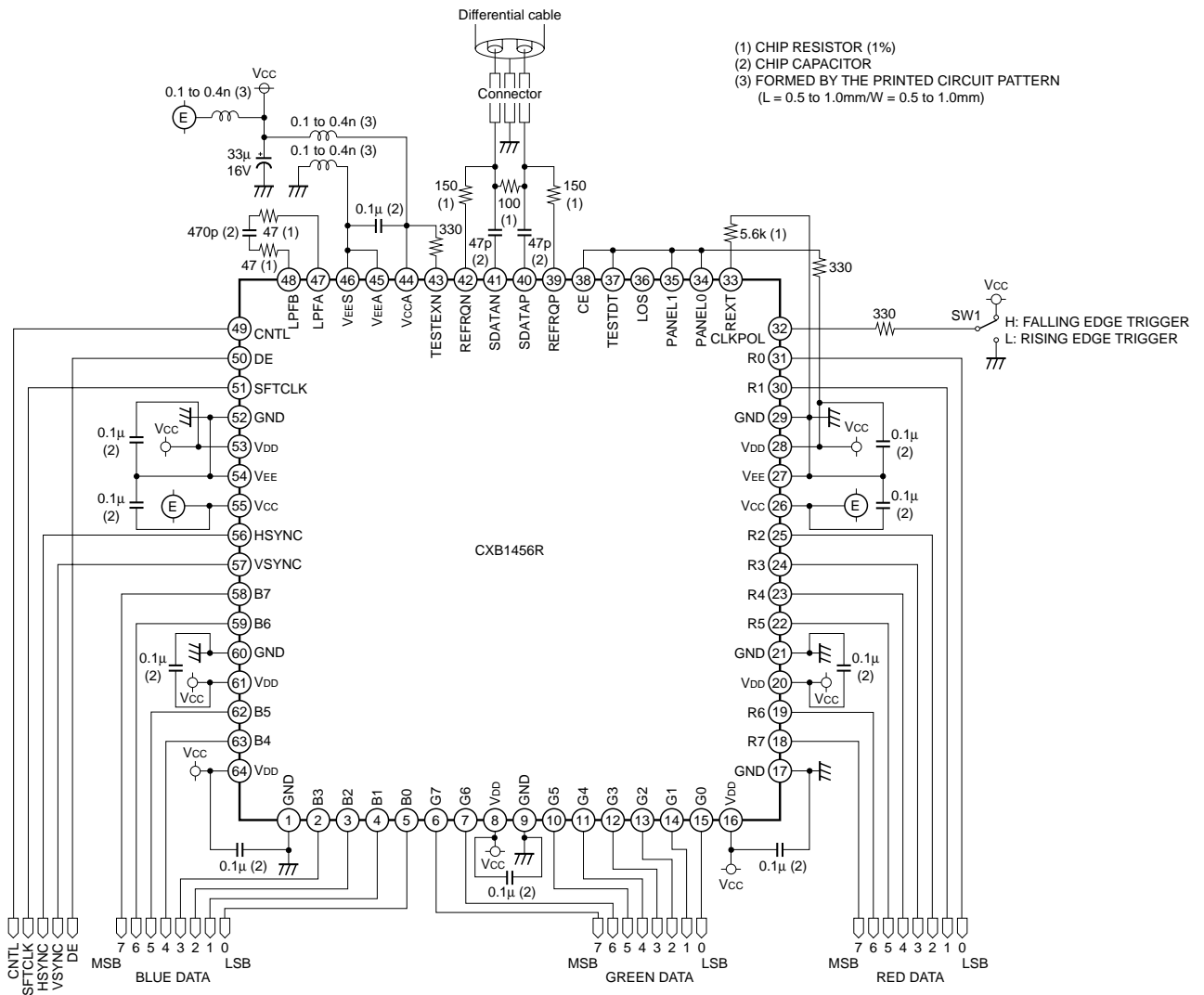

Application circuits shown are typical examples illustrating the operation of the devices. Sony cannot assume responsibility for any problems arising out of the use of these circuits or for any infringement of third party patent and other right due to same.

Fig. 12. Recommended application circuit

Recommended Printed Circuit Board Structure

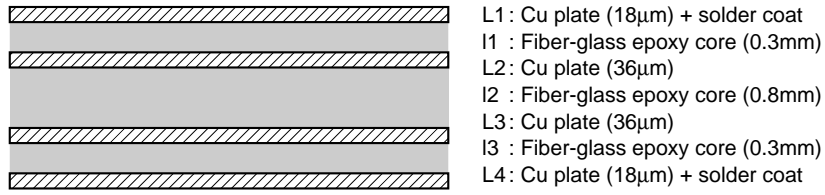

Fig. 13. Recommended Printed Circuit Board Structure

Recommended Printed Circuit Board Pattern

POWER and special signal routing example

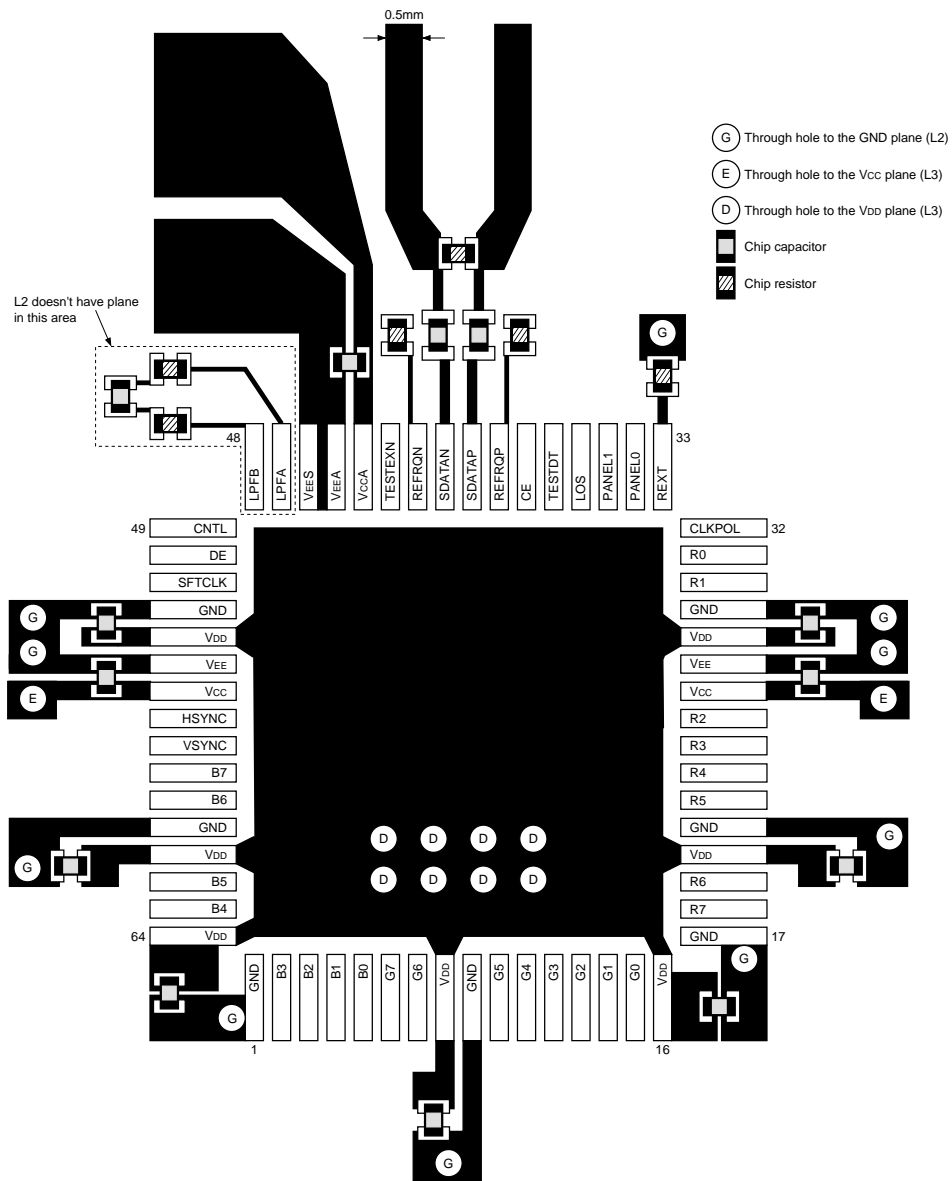

Fig. 14. Recommended Printed Circuit Board Pattern

**Micro Strip Line**

For maximum performance, the impedance between the pins SDDATAP/N of the LSI and the footprint of the connector should be 50Ω using a micro strip line. 50Ω impedance can be reached when using 0.5mm width pattern lines on L1 using this circuit board structure. The length of the lines should be identical and through-hole should not be used. L2 is recommended as the large ground plane.

**Terminators**

Terminators (100Ω resistor) should be located as close to the LSI as possible.

**Filter Devices and Reference Resistors**

Capacitors and resistors which are connected to LPFA/B and REXT are filters and reference resistors. The region of Layer 2 (L2) is under the device and conductive patterns. The ground plane should be taken off in order to reduce parasitic capacitors.

**Bypass Capacitors**

Bypass capacitors (0.1μF SMD type) should be located as close to the pins as possible. Refer to the recommendation.

## Recommendation for Cable and Connector Characteristics

The GVIF system uses terminators at both ends (transmitter and receiver), a cable equalizer and a small amplitude differential signal. In order to solve the problems of high speed data transmission such as signal reflection, reduce the signal level and EMI. In order to achieve the best solution, note the following:

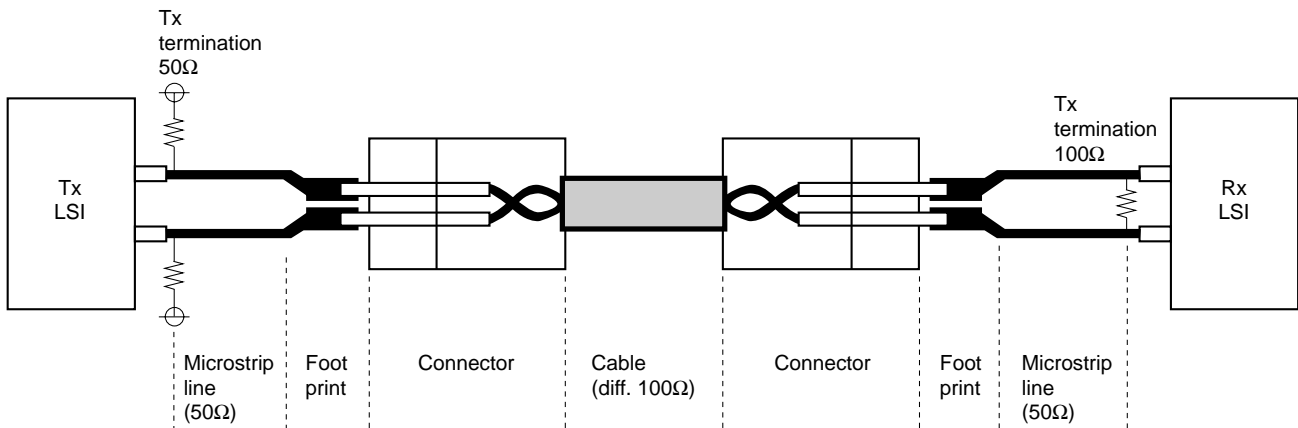

It is important to note the following issues for a good data transmission system:

- Good impedance matching
  - Differential impedance should be fit to the recommended template on the next page.
- Cable loss should be small and the loss curve should be smooth.
  - Maximum loss should be less than 6dB at 1GHz.
  - See the next page.
- Skew of POS/NEG (differential signal) should be small
  - Less than 12% of 1-bit time or 160ps@VGA, 100ps@SVGA, 60ps@XGA.
- Good EMI performance cable and connectors.

In order to satisfy these issues, the recommendations are as follows:

- Use the differential cable which provides good controlled impedance, low loss and good skew matching.
  - A shielded twisted pair (STP) cable is recommended.
- Use a low reflectance connector.
- To minimize interference from other signals, high speed signal lengths should be identical.
- Use double shielded cable.

**Recommended Transmission Path : Differential impedance template**

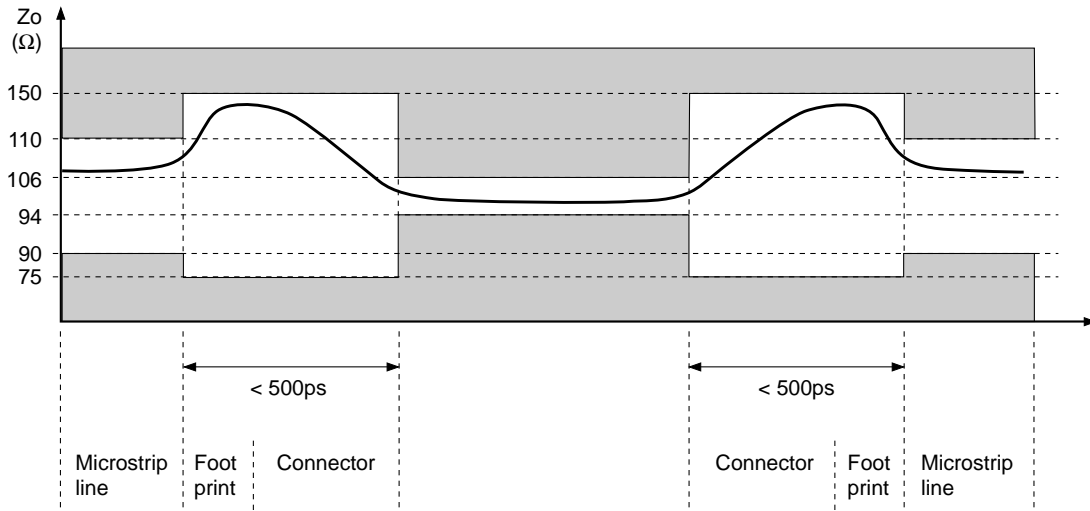

**Recommended Transmission Path : Attenuation Characteristics**

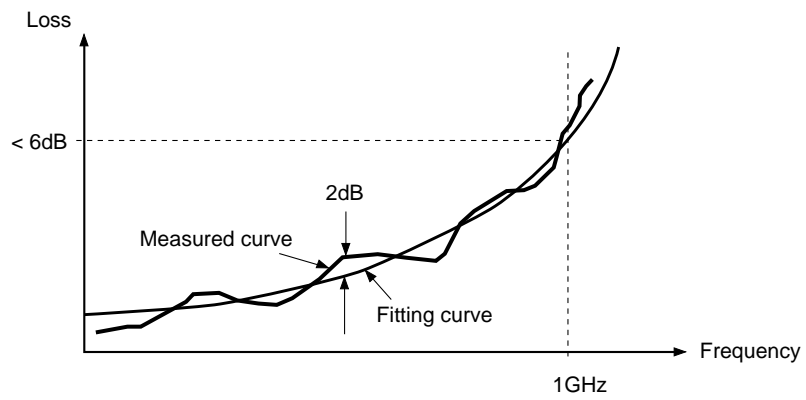

TTL output waveform with CL = 8pF

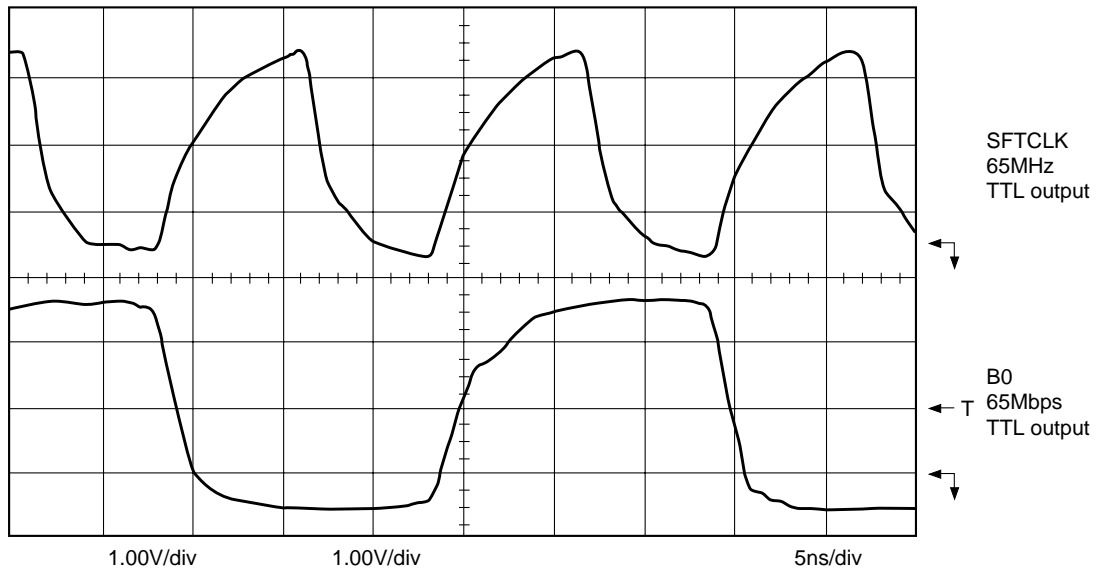

SFTCLK Power spectrum

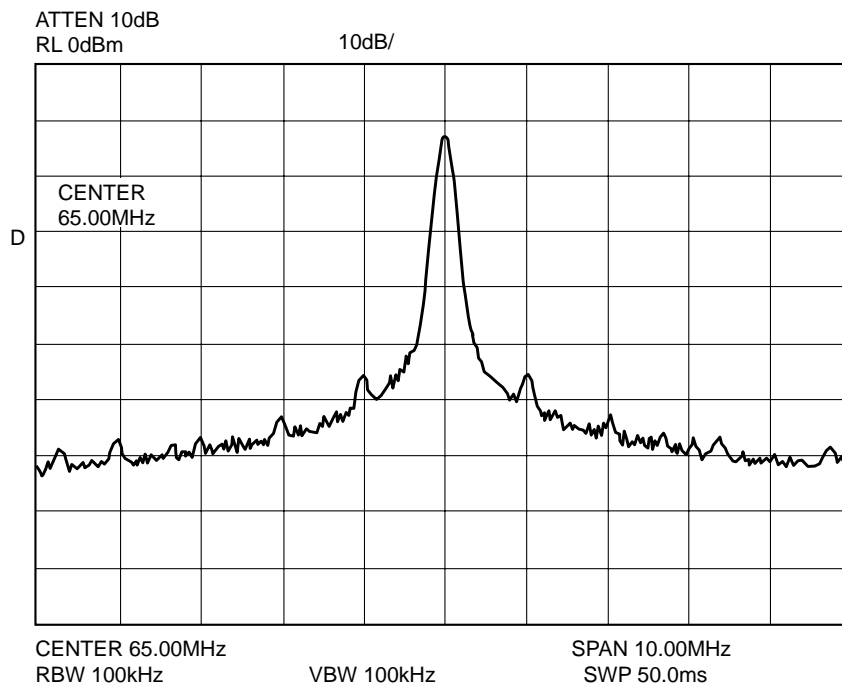

Package Outline Unit: mm

48PIN LQFP (PLASTIC)

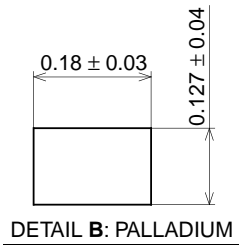
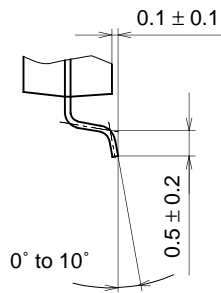
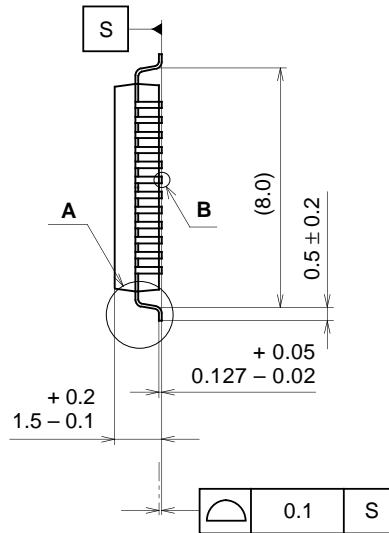
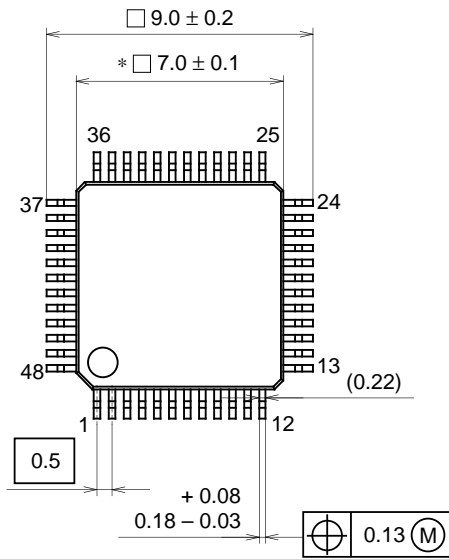

NOTE: Dimension "\*" does not include mold protrusion.

PACKAGE STRUCTURE

SONY CODE	LQFP-48P-L01
EIAJ CODE	P-LQFP48-7x7-0.5
JEDEC CODE	_____

PACKAGE MATERIAL	EPOXY RESIN
LEAD TREATMENT	PALLADIUM PLATING
LEAD MATERIAL	COPPER ALLOY
PACKAGE MASS	0.2g



LittleDiode supplies new, hard to find or obsolete electronic components and semiconductors all over the world.

With over two million different components listed you are sure to find the part you need.

Feel free to visit us today at our online store:

[LittleDiode.com](http://LittleDiode.com)

Looking forward to providing you with the best possible service.