

VGA/SVGA/XGA 24bit Receiver

Description

CXB1454R is the 1 chip deserializer for VGA/SVGA/XGA 24bit color digital RGB, and meet to the Gigabit Video Interface specification.

Features

- 1 chip receiver for serial transmission of 24-bit color VGA/SVGA/XGA picture
- On chip cable equalizer circuit to compensate the cable loss
- On chip PLL circuit for data and clock recovery
- On chip panel mode automatically selectable circuit
- TTL compatible I/O
- Support 1 pixel/shiftclock mode with 1 chip and 2 pixel/shiftclock mode with 2 chips
- +3.3V single power supply
- Low power consumption
- 64pin plastic LQFP package with body size 14mm × 14mm

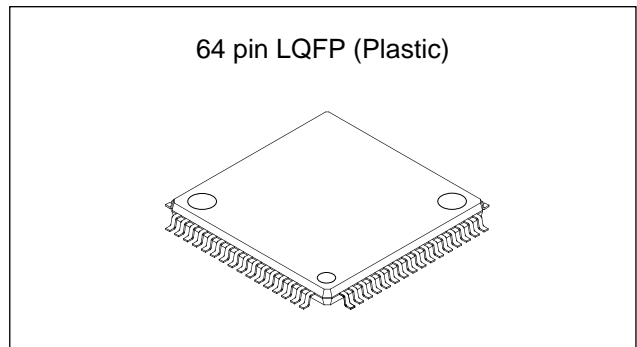

Absolute Maximum Ratings

• Supply voltage	Vcc	4.0	V
• Storage temperature	Tstg	-65 to +150	°C
• Allowable power dissipation	Pd	1710	mW

Recommended Operating Condition

• Supply voltage	Vcc	3.3 ± 0.16	V
• Operating temperature	Topr	0 to +60	°C

Structure

Bipolar silicon monolithic IC

Block Diagram & Pin out

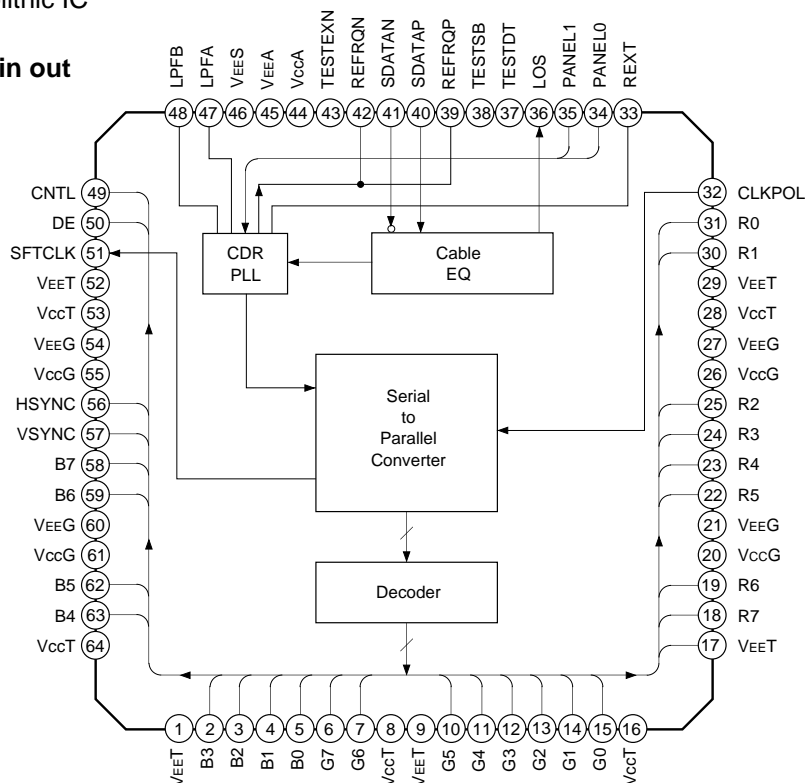

Fig. 1. Block Diagram & Pin out

Sony reserves the right to change products and specifications without prior notice. This information does not convey any license by any implication or otherwise under any patents or other right. Application circuits shown, if any, are typical examples illustrating the operation of the devices. Sony cannot assume responsibility for any problems arising out of the use of these circuits.

Pin List**Tab. 1. Power/Ground**

Pin Name	Pin Number	Descriptions
VccT	8, 16, 28, 53, 64	TTL power surpply, should be connected to $3.3V \pm 5\%$
VEET	1, 9, 17, 29, 52	TTL ground, connected to 0V
VccG	20, 26, 55, 61	Logical core power surpply, connected to $3.3V \pm 5\%$
VEEG	21, 27, 54, 60	Logical core ground, connected to 0V
VccA	44	Analog power surpply, connected to $3.3V \pm 5\%$
VEEA	45	Analog ground, connected to 0V
VEES	46	Analog substrate, connected to 0V

Tab. 2. Digital Signals

Pin Name	Pin Number	Type	Descriptions	Equivalent circuit	
SFTCLK	51	TTL out	Shift clock, for the data fetch at falling or rising edge		
RED (7 to 0) GRN (7 to 0) BLU (7 to 0)	18, 19, 22, 23, 24, 25, 30, 31, 6, 7, 10, 11, 12, 13, 14, 15, 58, 59, 62, 63, 2, 3, 4, 5	TTL out	Pixel data		
HSYNC	56	TTL out	Hsync data		
VSYNC	57	TTL out	Vsync data		
CNTL	49	TTL out	Control data		
DE	50	TTL out	Display enable data		
LOS	36	TTL out	Los of signal		
PANEL (1, 0)	35, 34	TTL in	Panel mode select switch		
CLKPOL	32	TTL in	Trigger edge select switch		
TESTEXN TESTDT TESTSB	43, 37, 38	TTL in	Reserved for TEST under fabrication		
SDATAP/N	40, 41	Rx	Serial input		
REFRQP/N	39, 42	Rx	Refclk request		

Tab. 3. Special

Pin Name	Pin Number	Descriptions	Equivalent circuit
REXT	33	External Resister	
LPFA/B	47, 48	External loop filter	

Electrical characteristics

Tab. 4. Absolute Maximum Rating

Description	Symbol	Min.	Typ.	Max.	Unit	Comments
Power supply voltage	V _{CC}	-0.3		4	V	
TTL DC input voltage	V _{I_T}	-0.5		5.5	V	
TTL output current (High)	I _{OH_T}	-20		0	mA	
TTL output current (Low)	I _{OL_T}	0		20	mA	
Serial input pin voltage	V _{sdin}	-0.5		V _{CC} + 0.5	V	
REFRQ output pin voltage	V _{RQout}	0.5		V _{CC} + 0.5	V	
Storage temperature	T _{stg}	-65		150	°C	

Tab. 5. Recommended Operating Conditions

Description	Symbol	Min.	Typ.	Max.	Unit	Comments
Power supply voltage (Include V _{CC} T5)	V _{CC}	3.135	3.3	3.465	V	
Operating temperature	T _{opr}	0		60	°C	

Tab. 6. DC Characteristics (Under the recommended conditions. See Tab. 5)

Description	Symbol	Min.	Typ.	Max.	Unit	Conditions
Input HIGH voltage (TTL)	V _{IH_T}	2		5.5	V	
Input LOW voltage (TTL)	V _{IL_T}	0		0.8	V	
Input HIGH current (TTL)	I _{IH_T}			20	μA	V _{IN} = V _{CC}
Input LOW current (TTL)	I _{IL_T}	-400			μA	V _{IN} = 0
Output HIGH voltage (TTL)	V _{OH_T}	2.25			V	I _{OH} = -0.2mA
Output LOW voltage (TTL)	V _{OL_T}			0.5	V	I _{OL} = 4mA
Output HIGH current (REFRQ)	I _{OH_RQ}	-0.1	0	+0.1	mA	See Fig. 3, 4 R _{EXT} = 1.3kΩ
Output LOW current (REFRQ)	I _{OL_RQ}	7.8		11	mA	
Input dynamic range (SDATA)	V _{IM_SD}	V _{CC} - 0.4		V _{CC} + 0.2	V	Common mode voltage
Input dynamic range (SDATA)	V _{ID_SD}	-0.5		+0.5	V	Differential voltage
Supply current	I _{CC}		325	440	mA	65MHz, All low pattern, Outputs open
			350	465	mA	65MHz, Worst case pattern See Fig. 8 Outputs open

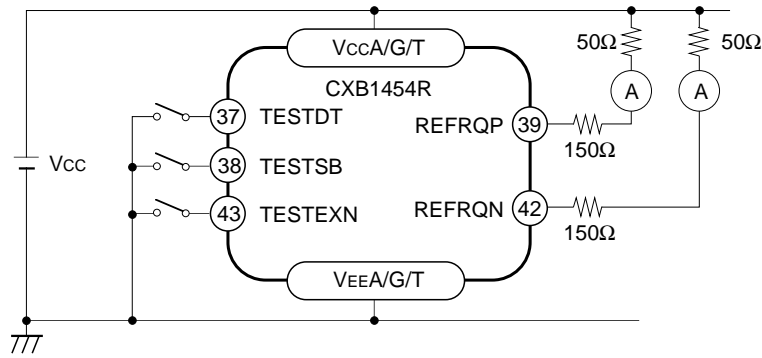

Fig. 2. IOH_RQ and IO_L_RQ DC measurement

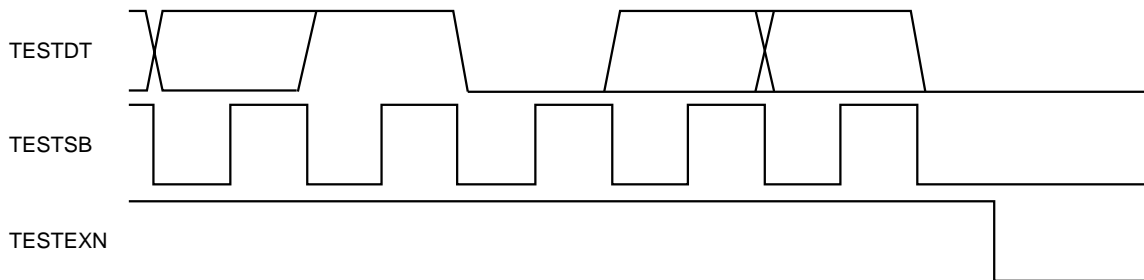

Fig. 3. IOH_RQ and IO_L_RQ DC measurement setting

Electrical characteristics

Tab. 7. AC Characteristics (Under the recommended conditons. See Tab. 5)

Description	Symbol	Min.	Typ.	Max.	Unit	Conditions
Minimum SFTCLK frequency	Fsftclk	65.0		25.0	MHz	
Maximum SFTCLK frequency						
SFTCLK duty factor	Dsftclk	40		60	%	Vth = 1.4V, CL = 10pF
Pixel/Sync/Cntl/DE setup to SFTCLK	Tsetup	16			ns	Vth = 1.4V, CL = 10pF
		10				25MHz
		5				40MHz
Pixel/Sync/Cntl/DE hold to SFTCLK	Thold	17			ns	Vth = 1.4V, CL = 10pF
		11				25MHz
		6				40MHz
SFTCLK rise time	Torc			3	ns	0.8 to 2.0V, CL = 10pF
SFTCLK fall time	Tofc			2.5	ns	2.0 to 0.8V, CL = 10pF
Pixel/Sync/Cntl/DE rise time	Tofd			4.5	ns	0.8 to 2.0V, CL = 10pF
Pixel/Sync/Cntl/DE fall time	Tord			2	ns	2.0 to 0.8V, CL = 10pF
CLOCK mode assert time	TAclk		0.9		μs	
CLOCK mode deassert time	TDclk		50		μs	
LOS signal assert time	TAlos		0.5		μs	
LOS signal deassert time	TDlos		0.1		μs	

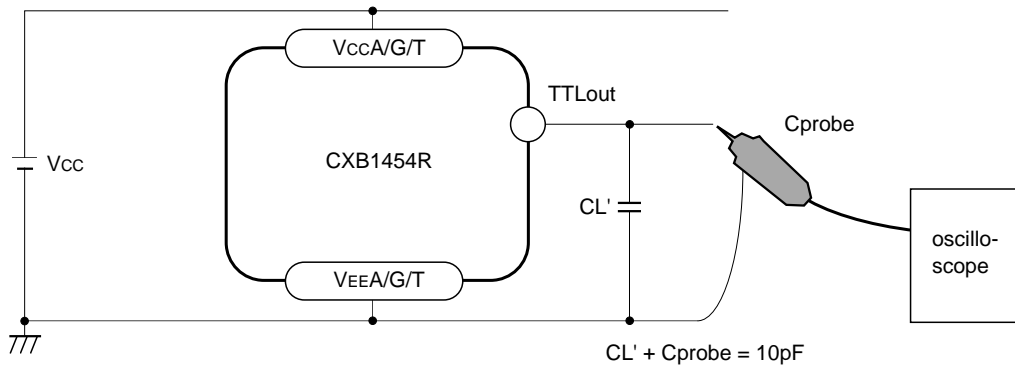

Fig. 4. Pixel/Sync/Cntl/DE waveform measurement

Timing Chart

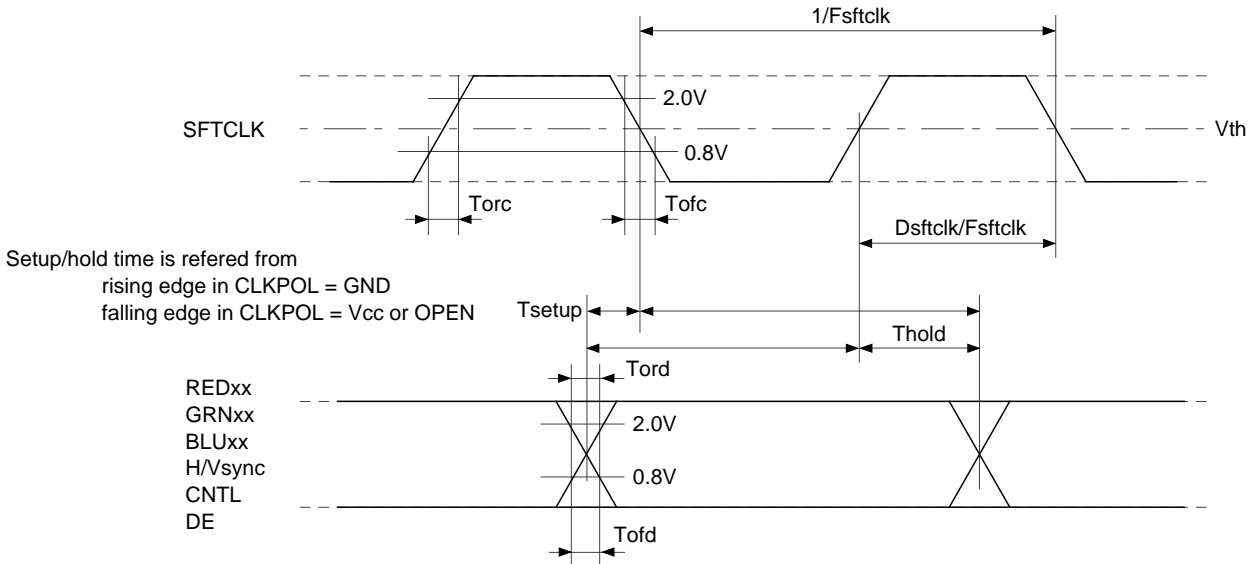

Fig. 5. TTL output timing

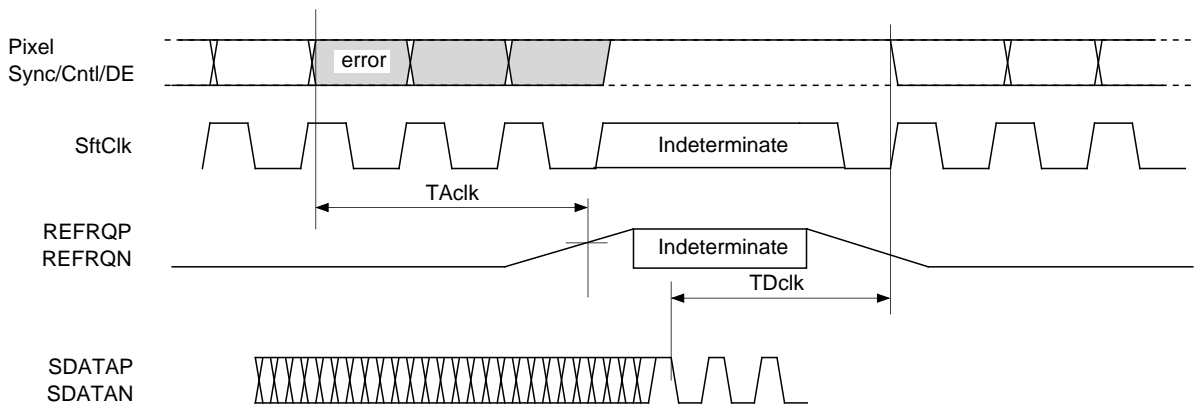

Fig. 6. Refclk request timing

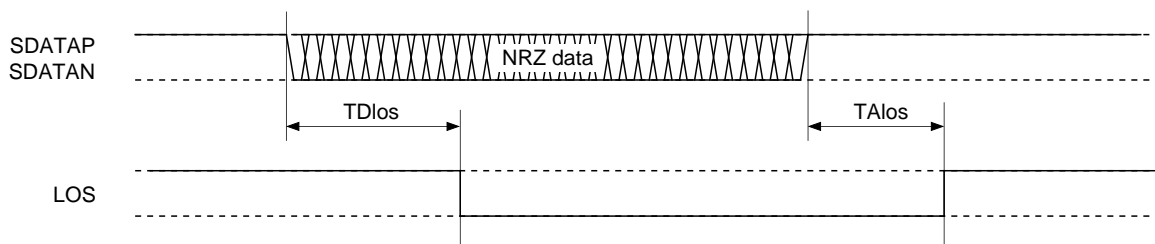

Fig. 7. Idle mode timing

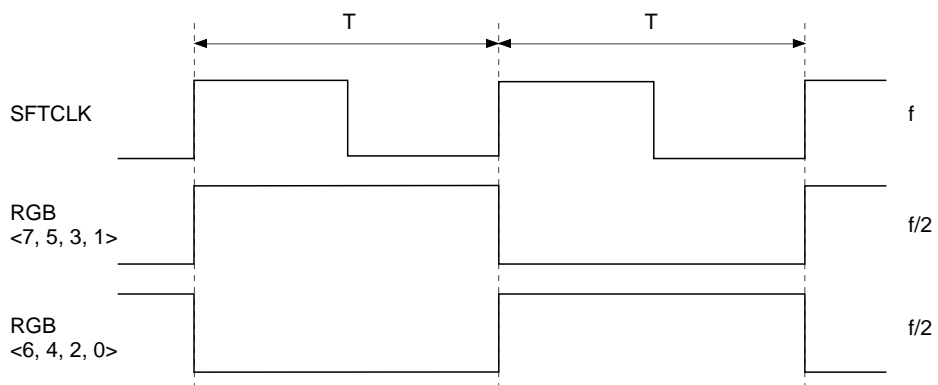

Fig. 8. Worst case test pattern

CLKPOL Pin Control

The CLKPOL pin is used to select the SFTCLK trigger edge. (See Table 8.)

The CLKPOL pin is open High TTL input.

Table 8. SFTCLK Polarity

CLKPOL	Receiver operation trigger
L	Rising edge
H	Falling edge

PANEL1 and 0 Pin Control

The PANEL1 and 0 pins are used to select the panel mode. (See Table 9.)

For the normal use, the all frequencies of SFTCLK (25MHz to 65MHz) can be covered by fixing both PANEL1 and 0 to High.

The PANEL1 and 0 pins are open High TTL inputs.

Table 9. Panel Mode

PANEL1	PANEL0	Supporting panel size	Shift clock	Serial rate
L	L	VGA (640 × 480)	25MHz	750Mbps
L	H	SVGA (800 × 600)	40MHz	1200Mbps
H	L	XGA (1024 × 768)	65MHz	1950Mbps
H	H	VGA to XGA	25MHz to 65MHz	750Mbps to 1950Mbps

Test Pin Control

The TESTEXN, TESTDT and TESTSB pins are for test only. Select normal mode. (See Table 10.)

The TESTEXN, TESTDT and TESTSB pins are open High, TTL inputs.

Table 10. Test Mode

TESTEXN	TESTDT	TESTSB	Operation mode
L	X	X	Test mode
H	H	H	Normal mode

LOS Pin Output

The LOS pin shows the absence of proper level of SDATA signal. The LOS pin is High when the connector is disconnected or the transmitter is idle.

The LOS pin is TTL output.

Applications

CXB1454R GVIF receiver is applied to the digital RGB signal transmission for
 P/C with LCD monitor
 Video on demand system
 Monitoring system
 Graphical controller
 Projector
 Digital TV monitor
 Car navigation system
 with GVIF transmitter, CXB1455R.

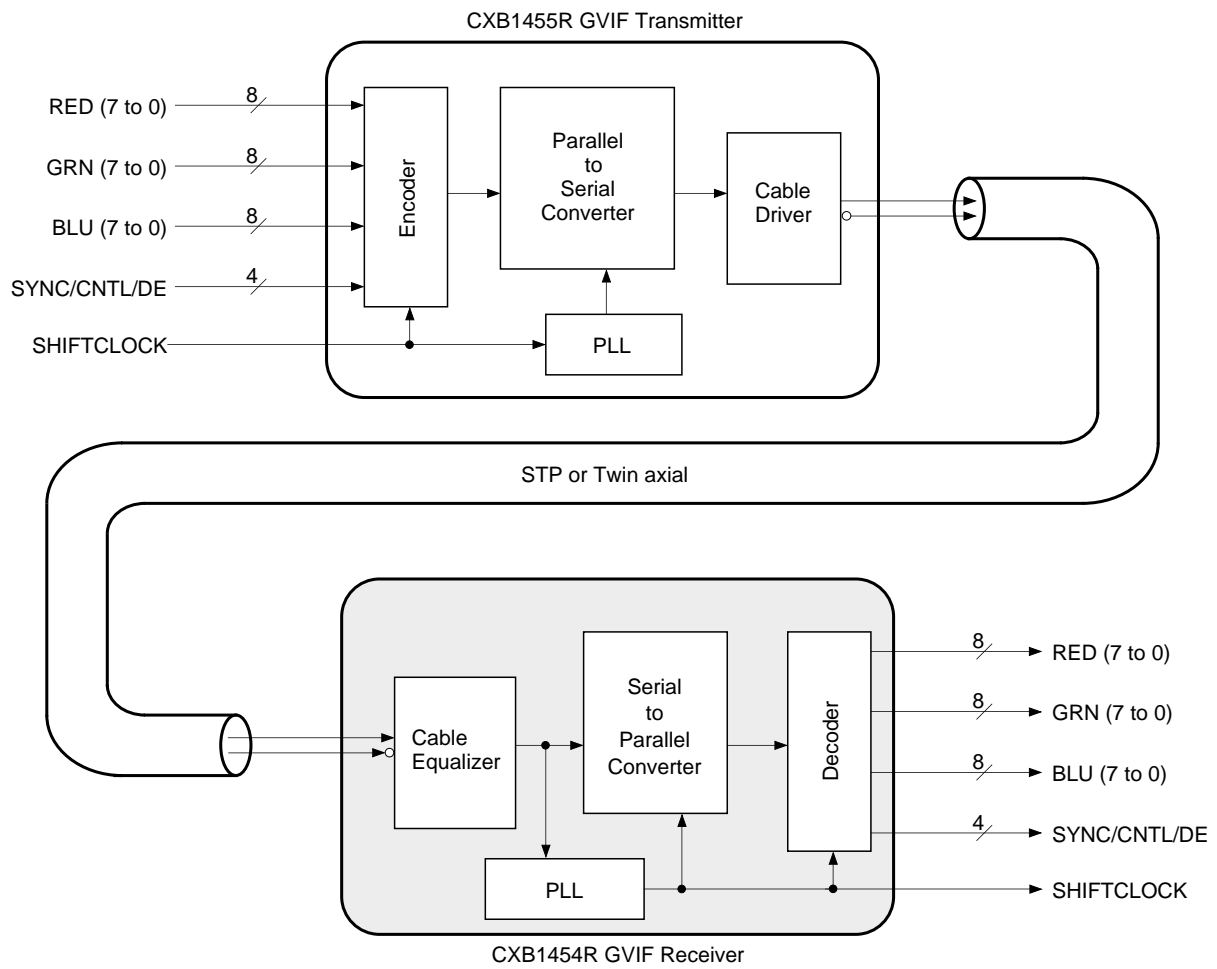
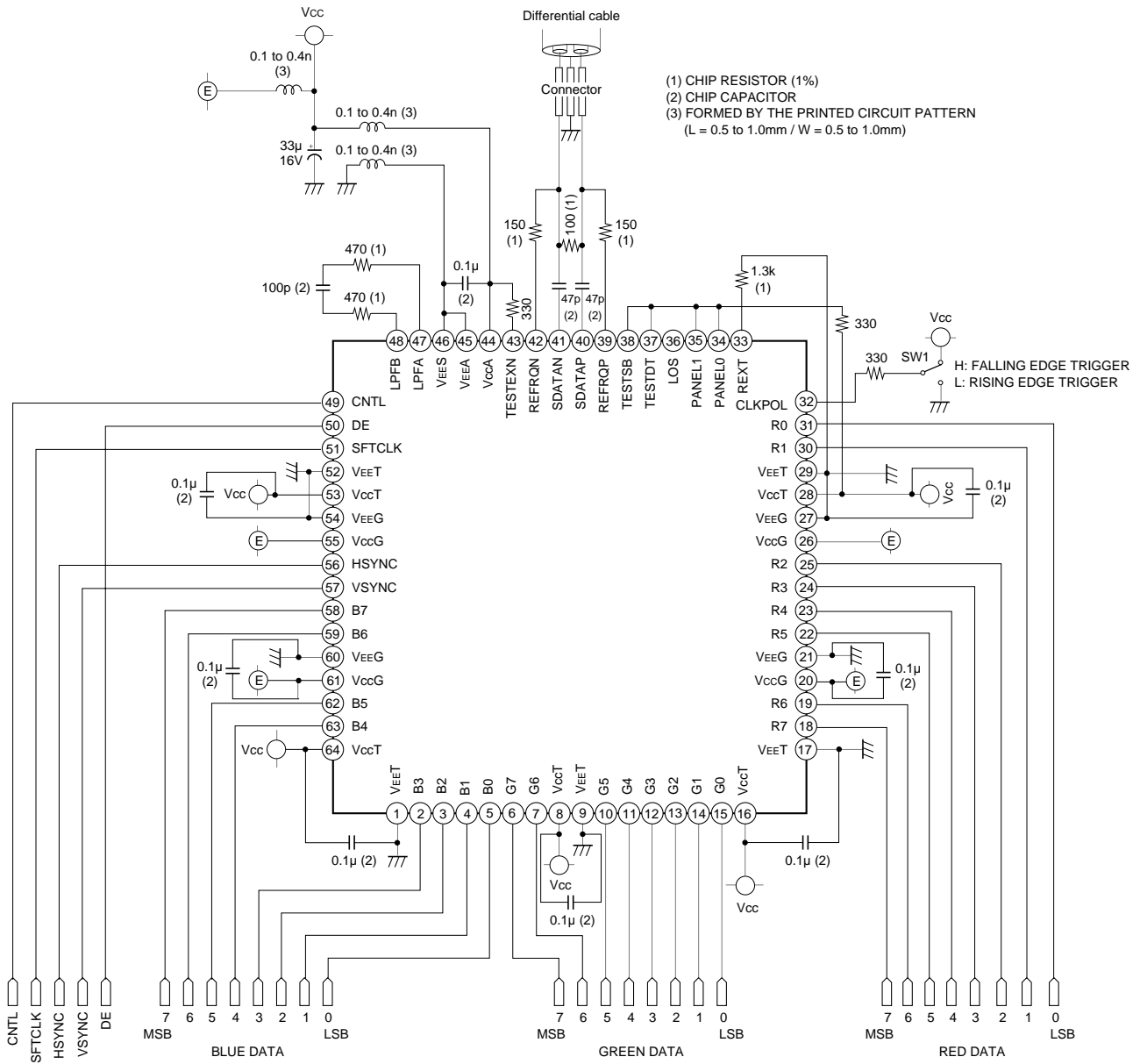

Fig. 9. Block Diagram of GVIF transceiver chip set

Application Circuit



Application circuits shown are typical examples illustrating the operation of the devices. Sony cannot assume responsibility for any problems arising out of the use of these circuits or for any infringement of third party patent and other right due to same.

Fig. 10. Recommended application circuit

Recommended Printed Circuit Board Structure

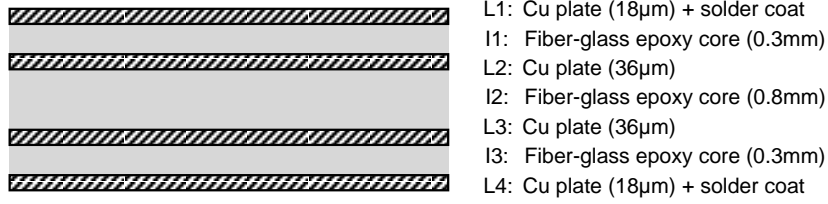

Fig. 11. Recommended Printed Circuit Board Structure

Recommended Printed Circuit Board Pattern

POWER and special signal routing example

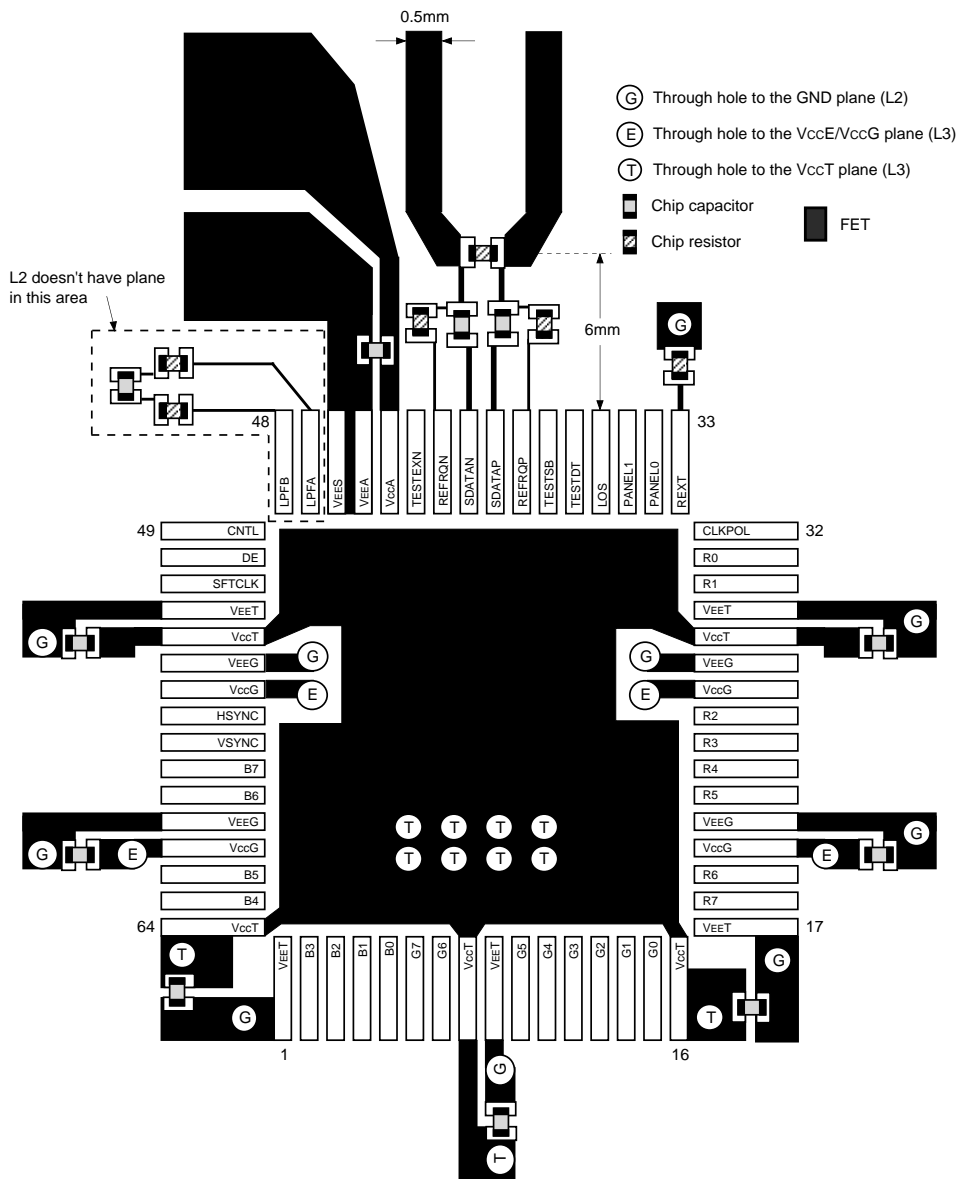

Fig. 12. Recommended Printed Circuit Board Pattern

Micro Strip Line

For maximum performance, the impedance between the pins SDDATAP/N of the LSI and the footprint of the connector should be 50Ω using a micro strip line. 50Ω impedance can be reached when using 0.5mm width pattern lines on L1 using this circuit board structure. The length of the lines should be identical and through-hole should not be used. L2 is recommended as the large ground plane.

Terminators

Terminators (100Ω resistor) should be located as close to the LSI as possible.

Filter Devices and Reference Resistors

Capacitors and resistors which are connected to LPFA/B and REXT are filters and reference resistors. The region of Layer 2 (L2) is under the device and conductive patterns. The ground plane should be taken off in order to reduce parasitic capacitors.

Bypass Capacitors

Bypass capacitors (0.1μF SMD type) should be located as close to the pins as possible. Refer to the recommendation.

Recommendation for Cable and Connector Characteristics

The GVIF system uses terminators at both ends (transmitter and receiver), a cable equalizer and a small amplitude differential signal. In order to solve the problems of high speed data transmission such as signal reflection, reduce the signal level and EMI. In order to achieve the best solution, note the following:

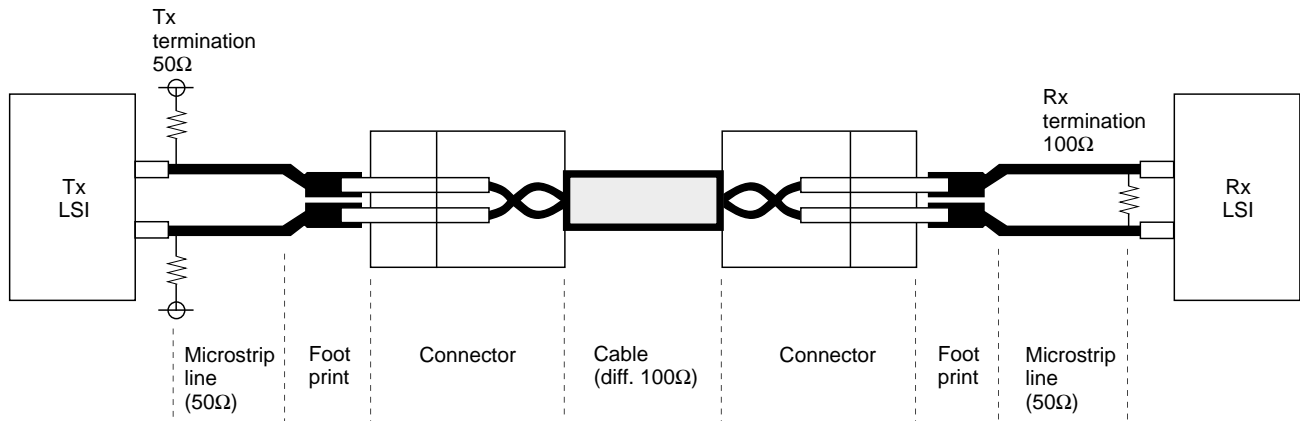

It is important to note the following issues for a good data transmission system:

- Good impedance matching
Differential impedance should be fit to the recommended template on the next page.
- Cable loss should be small and the loss curve should be smooth.
Maximum loss should be less than 15dB at 1GHz for the CXB1454R which has a built-in cable equalizer.
See the next page.
- Skew of POS/NEG (differential signal) should be small
Less than 12% of 1-bit time or 160ps@VGA, 100ps@SVGA, 60ps@XGA.
- Good EMI performance cable and connectors.

In order to satisfy these issues, the recommendations are as follows:

- Use the differential cable which provides good controlled impedance, low loss and good skew matching.
A shielded twisted pair (STP) cable is recommended.
- Use a low reflectance connector.
- To minimize interference from other signals, high speed signal lengths should be identical.
- Use double shielded cable.

Recommended Transmission Path : Differential impedance template

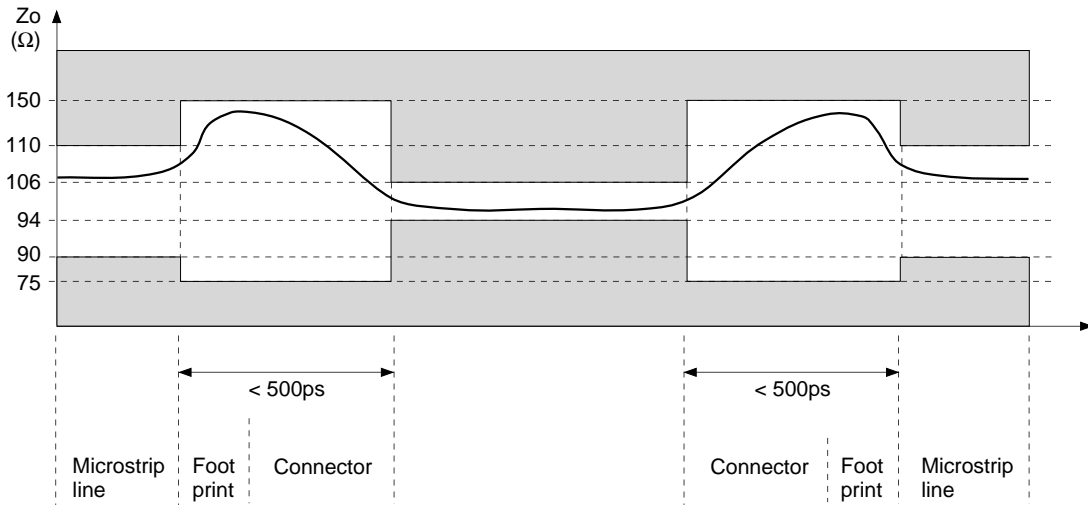

Recommended Transmission Path : Attenuation Characteristics

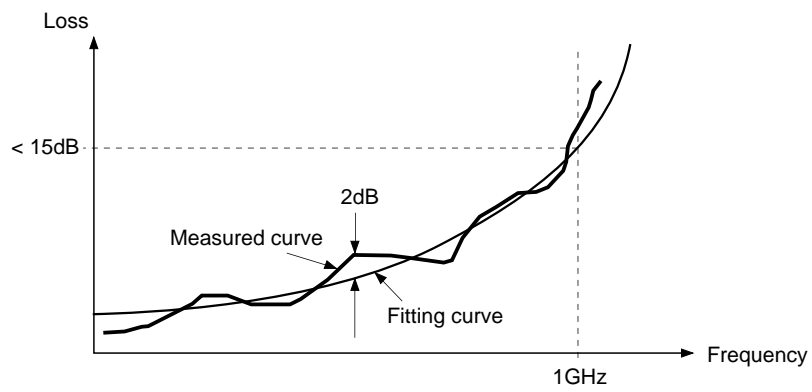

TTL output waveform with $C_L = 10\text{pF}$

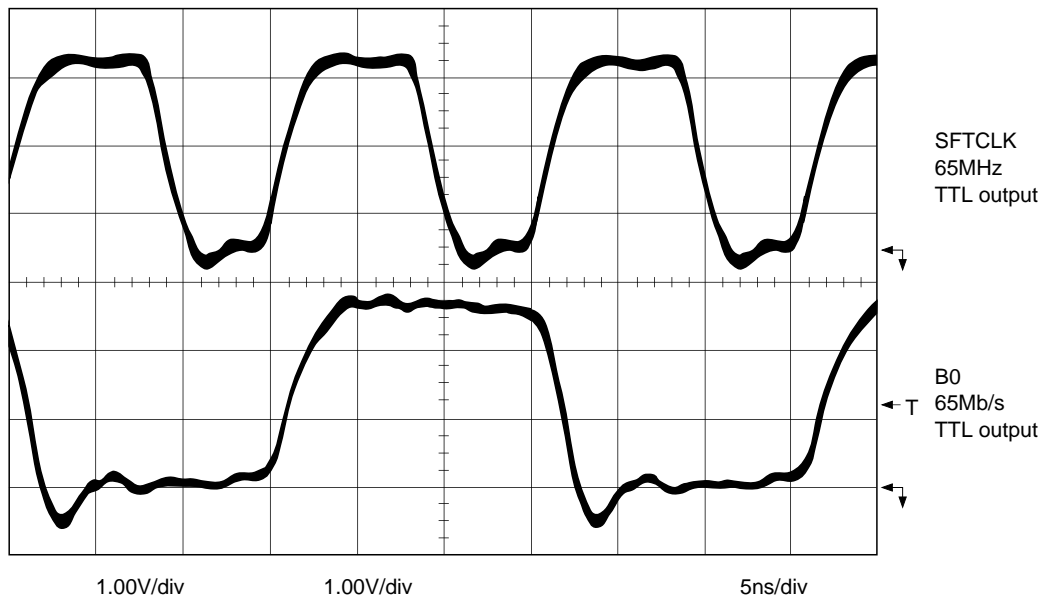

SFTCLK Power spectrum

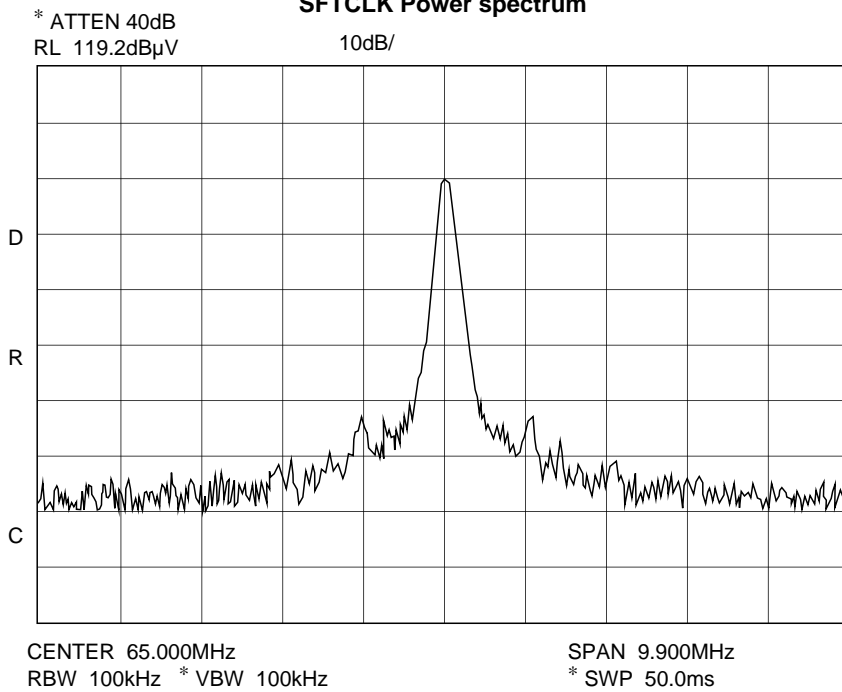

Package Outline

Unit: mm

64PIN LQFP (PLASTIC)

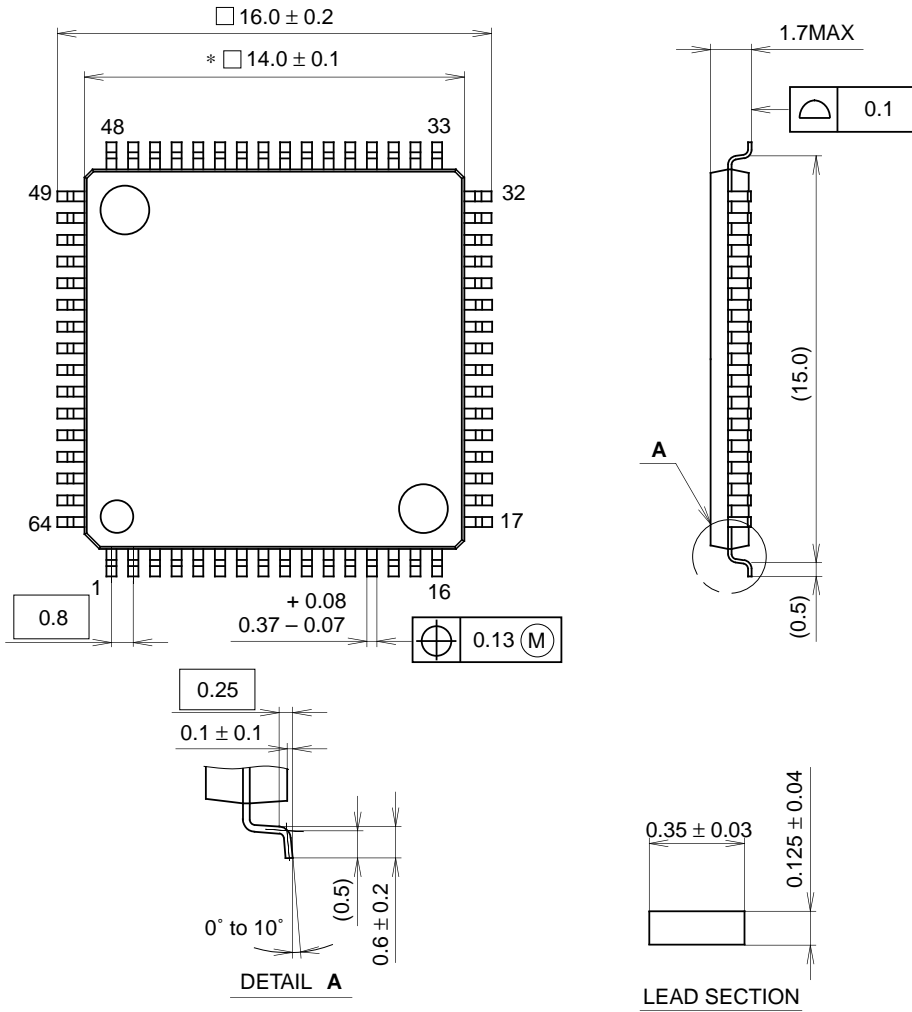

NOTE: Dimension "*" does not include mold protrusion.

PACKAGE STRUCTURE

SONY CODE	LQFP-64P-L02
EIAJ CODE	LQFP064-P-1414
JEDEC CODE	_____

PACKAGE MATERIAL	EPOXY RESIN
LEAD TREATMENT	PALLADIUM PLATING
LEAD MATERIAL	COPPER ALLOY
PACKAGE MASS	0.7g



LittleDiode supplies new, hard to find or obsolete electronic components and semiconductors all over the world.

With over two million different components listed you are sure to find the part you need.

Feel free to visit us today at our online store:

LittleDiode.com

Looking forward to providing you with the best possible service.