

Fingerprint Sensor

Description

The CXA3621GE is an electrostatic capacitance method fingerprint sensor.

This monolithic IC integrates the sensor block, sense amplifier (3-bit gain adjustment), sample-and-hold, output amplifier and output buffer needed to acquire fingerprint images, as well as the timing generator for determining the operation of these functions onto a single chip.

30 pin LLGA (Plastic)

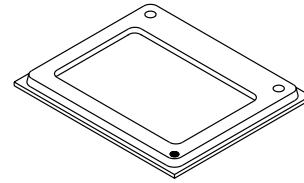

Features

- Electrostatic capacitance type sensor (charge transfer method)
- Number of pixels: 192 × 128
- 317 DPI
- Low power consumption (50mW or less) * When P/S: 18μW or less
- Single 3.0V power supply
- Sensor gain control: 3 bits
- S/N ratio improved by on-chip sensor block parasitic capacitance cancel function

Applications

Fingerprint verification units

Structure

Silicon gate CMOS IC

Absolute Maximum Ratings (Ta = 25°C)

• Supply voltage	AV _{DD} , DV _{DD}	V _{SS} – 0.5 to +7.0	V
• Input voltage	V _I	V _{SS} – 0.5 to V _{DD} + 0.5	V
• Output voltage	V _O	V _{SS} – 0.5 to V _{DD} + 0.5	V
• Operating temperature	T _{opr}	–20 to +75	°C
• Storage temperature	T _{stg}	–25 to +125	°C
• Allowable power dissipation	P _D	1100	mW

Recommended Operating Conditions

• Supply voltage	AV _{DD} , DV _{DD}	2.7 to 3.6	V
• Ambient operating temperature	T _a	0 to +50	°C

Sony reserves the right to change products and specifications without prior notice. This information does not convey any license by any implication or otherwise under any patents or other right. Application circuits shown, if any, are typical examples illustrating the operation of the devices. Sony cannot assume responsibility for any problems arising out of the use of these circuits.

Block Diagram

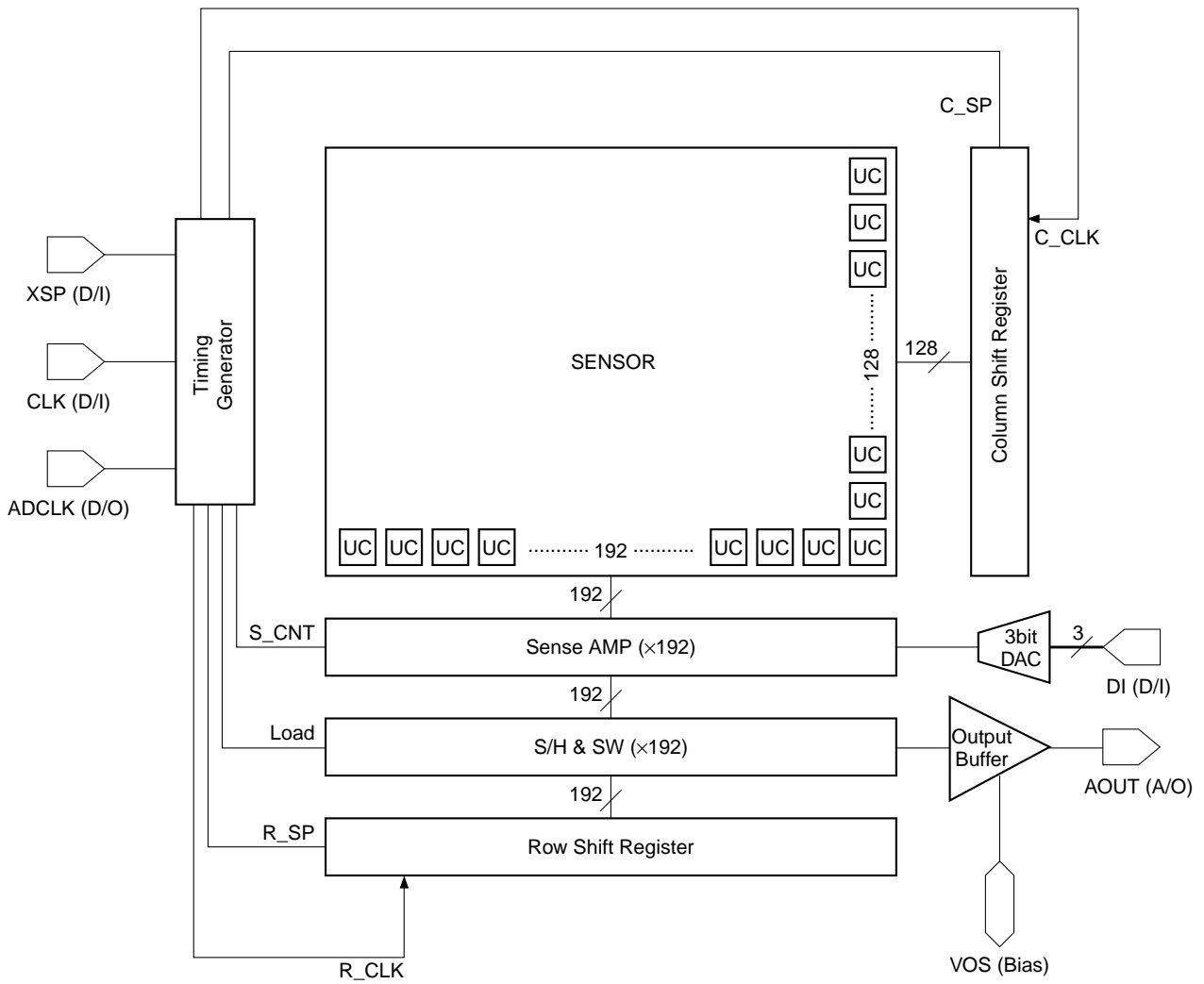

Detailed Block Diagram

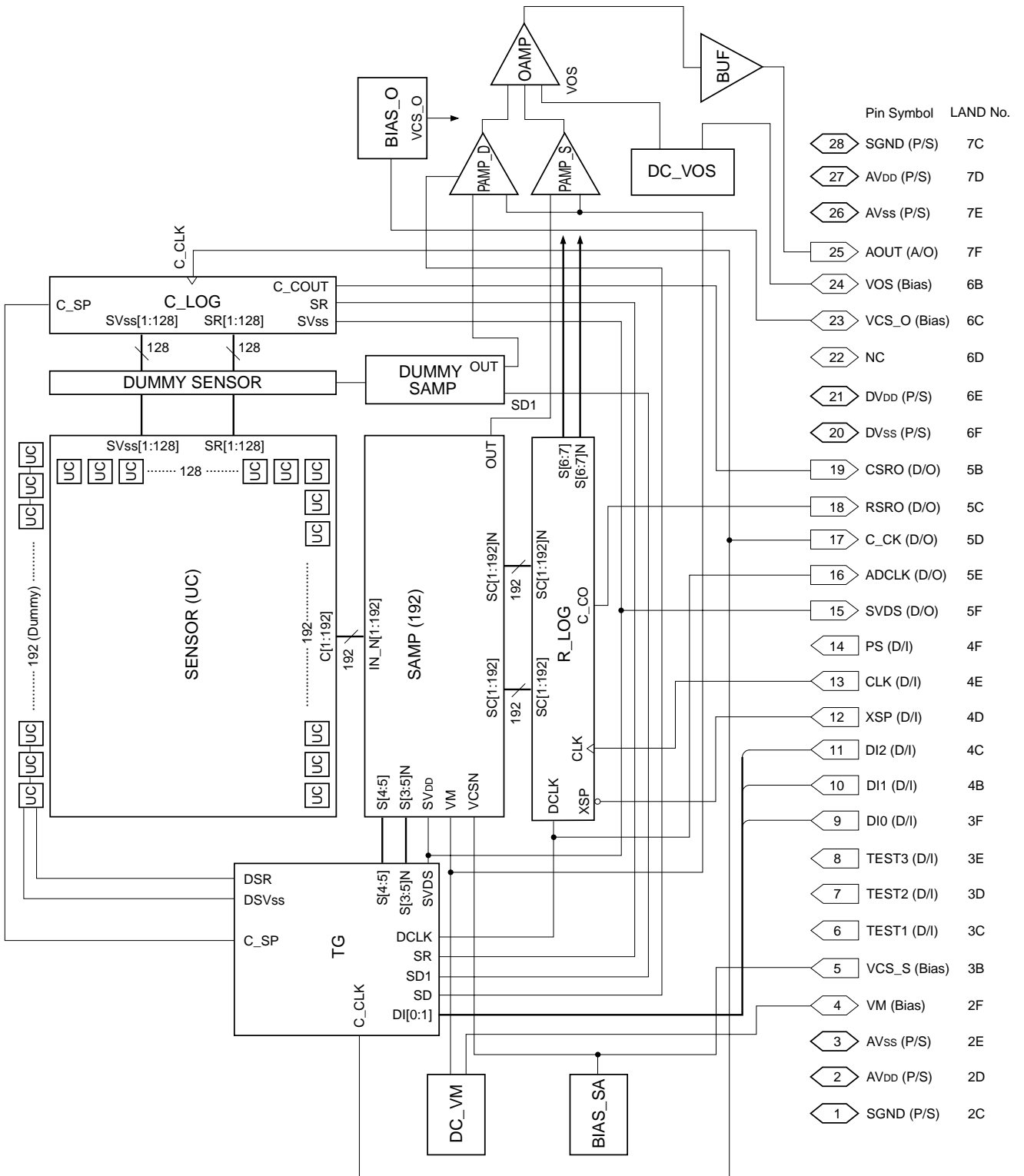

Pin Description

Serial No.	Land No.	Symbol	I/O	Description
—	2B	SUB	Power	Substrate electrode (chip rear surface electrode) 3.0V (V _{DD}).
1	2C	SGND	Power	Sensor lightning conductor electrode. (Connect to the GND which is the other system of operating power supply.)
2	2D	AV _{DD}	Power	Analog power supply 3.0V.
3	2E	AV _{SS}	Power	Analog GND.
4	2F	VM	A/O	Sense amplifier reference voltage monitor 1.5V (1/2 V _{DD}). (Do not connect.)
5	3B	VCS_S	A/O	Sense amplifier current source bias monitor. (Do not connect.)
6	3C	TEST1	D/I	Test mode selection. (Connect to GND.)
7	3D	TEST2	D/I	Test mode selection. (Connect to GND.)
8	3E	TEST3	D/I	Test mode selection. (Connect to GND.)
9	3F	DI0	D/I	Gain setting input (LSB).
10	4B	DI1	D/I	Gain setting input.
11	4C	DI2	D/I	Gain setting input (MSB).
12	4D	XSP	D/I	Sense start pulse (negative pulse). The column and row shift registers and the timing generator are cleared by this signal.
13	4E	CLK	D/I	Main clock 2MHz.
14	4F	PS	D/I	Power saving mode setting. (Low: Operation; High: Standby)
15	5F	SVDS	D/O	Integrating pulse monitor. (Do not connect.)
16	5E	ADCLK	D/O	Delay clock. (Do not connect.)
17	5D	C_CK	D/O	Column shift register clock. (Do not connect.)
18	5C	RSRO	D/O	Column shift register final output. (Do not connect.)
19	5B	CSRO	D/O	Row shift register final output. (Do not connect.)
20	6F	DV _{SS}	Power	Digital GND.
21	6E	DV _{DD}	Power	Digital power supply 3.0V.
22	6D	NC	—	No connection. (Do not connect.)
23	6C	VCS_O	A/O	Output amplifier current source bias monitor. (Do not connect.)
24	6B	VOS	A/O	Output amplifier reference voltage monitor 1.09V (4/11V _{DD}). (Do not connect.)
25	7F	AOUT	A/O	Sensor output.
26	7E	AV _{SS}	Power	Analog GND.
27	7D	AV _{DD}	Power	Analog power supply 3.0V.
28	7C	SGND	Power	Sensor lightning conductor electrode. (Connect to the GND which is the other system of operating power supply.)

Electrical Characteristics

DC Characteristics

(V_{SS} = 0V, Ta = 25°C)

Item	Symbol	Conditions	Min.	Typ.	Max.	Unit
Analog supply voltage	AV _{DD}		2.7	3.0	3.6	V
Digital supply voltage	DV _{DD}		2.7	3.0	3.6	V
Current consumption (for operation)	I _{DD1}	V _{DD} = 3V, P/S = L	5.0	8.5	13.0	mA
Current consumption (for standby)	I _{DD2}	V _{DD} = 3V, P/S = H, CLK = L			5	μA
Input voltage (High)	V _{IH}	Digital (CMOS) input cell	0.7V _{DD}		V _{DD}	V
Input voltage (Low)	V _{IL}	Digital (CMOS) input cell	V _{SS}		0.3V _{DD}	V
Output voltage (High)	V _{OH}	V _{DD} = 3V, I _{OH} = -800μA	2.6		3.0	V
Output voltage (Low)	V _{OL}	V _{DD} = 3V, I _{OL} = 2.4mA	0		0.4	V
Input leak current	I _L	V _{DD} = 3V, digital (CMOS) input cell [3V/0V]	-1		1	μA
Output voltage	VM	V _{DD} = 3V	1.4	1.5	1.6	V
Output voltage	VOS	V _{DD} = 3V	1.00	1.09	1.20	V

AC Characteristics

(V_{DD} = 3.0V, V_{SS} = 0V, Ta = 25°C)

Item	Symbol	Conditions	Min.	Typ.	Max.	Unit
Clock input period	CLK		400			ns
Number of sensor defects			0		3	Defects
Output voltage (Air_Level)	AOUT	*1	850	1090	1350	mV
Output voltage (Water_Level)	AOUT	*2	950	1200	1450	mV

*1 Output voltage Air Level means the output level in the condition where nothing is placed against the sensor surface (in other words, in air). This rating value is obtained by measuring 32 points within one line of the sensor output and then taking the average.

The gain setting for this measurement is (011).

*2 Output voltage Water Level specifies the degree to which the output level changes from the Air Level when a drop of water is placed on the sensor surface. However, it is unrealistic to place a drop of water on each sensor surface when sorting products, so 32 virtual capacitors (parasitic capacitance equal to the level when a drop of water is placed on the surface) are built into the sensor chip, and the average of these output values is calculated. The difference from the Air Level noted above becomes the Water Level.

The gain setting for this measurement is (011).

Electrical Characteristics Measurement Circuit

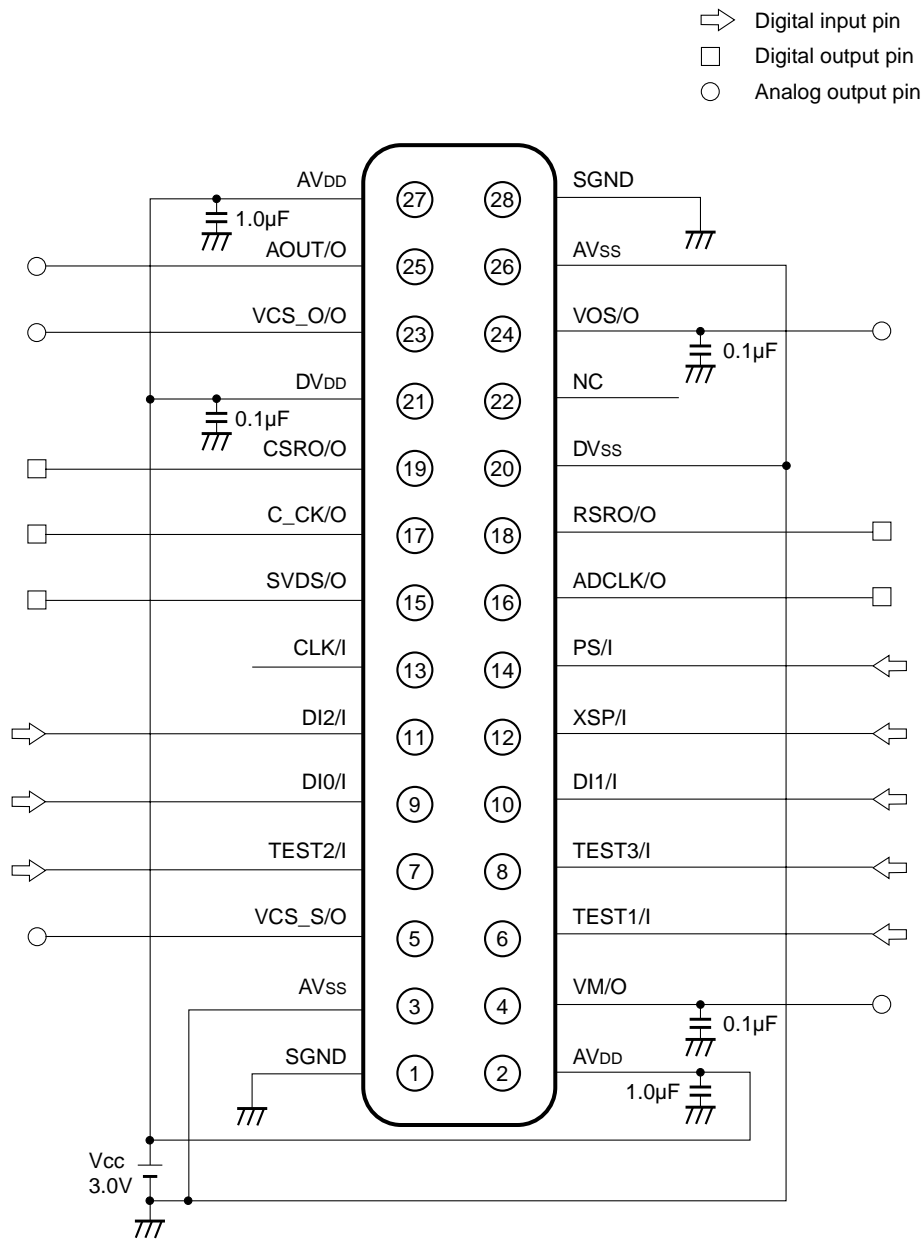

The load of 30pF or more is added to each pin.

Application Circuit

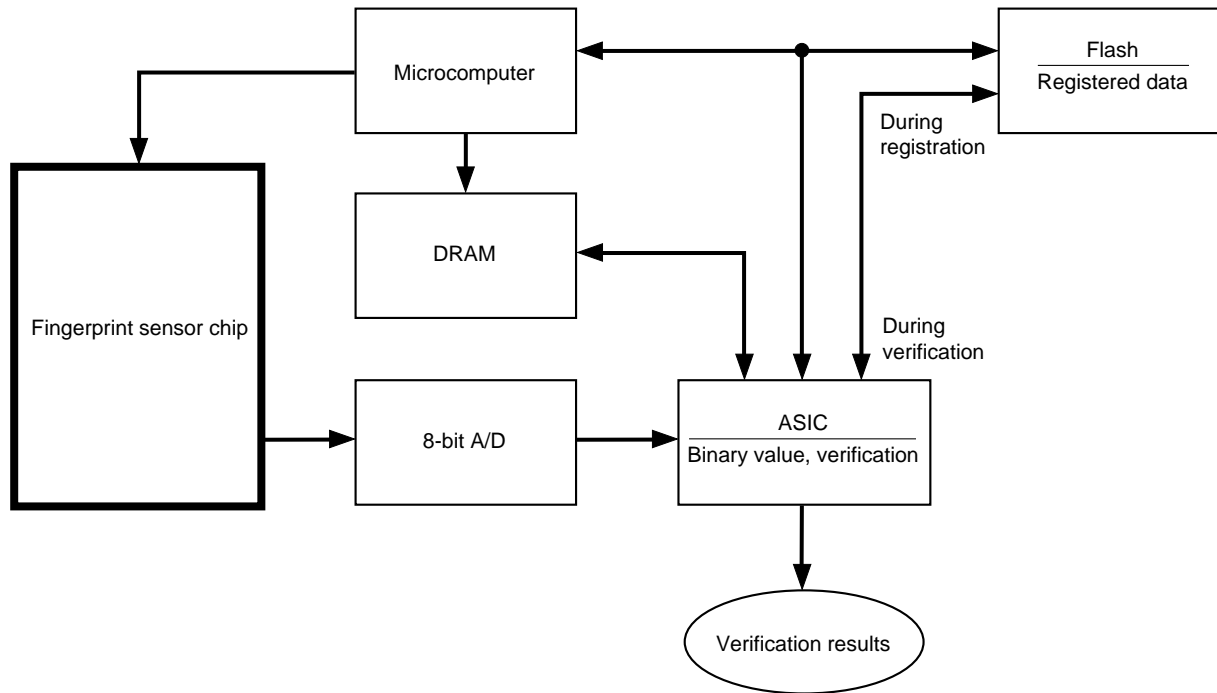

Application circuits shown are typical examples illustrating the operation of the devices. Sony cannot assume responsibility for any problems arising out of the use of these circuits or for any infringement of third party patent and other right due to same.

Description of Operation

• Fingerprint sensor principle

The principle of this newly developed fingerprint sensor is described below (Fig. 1). The sensor block contains an array of metal electrodes which are covered on top by an insulating film (overcoat). When a finger (which is conductive matter) is placed directly against this surface, the three elements of the metal electrode, the insulating film and the finger form a capacitor.

The difference between the fingerprint ridges and valleys is the difference in distance to the metal electrodes, and becomes the difference in the capacitance values of the individually formed capacitors. (The ridge capacitance values are determined by the dielectric constant of the insulating film, but the valleys contain air in addition to this, making the difference between the ridge and valley capacitance values even greater than the difference in distance.)

Using this principle, by applying a constant voltage to all metal electrodes, the charge level accumulated in each electrode differs, making it possible to output the unevenness of the fingerprint as an electric signal by transferring and converting these charges to voltages.

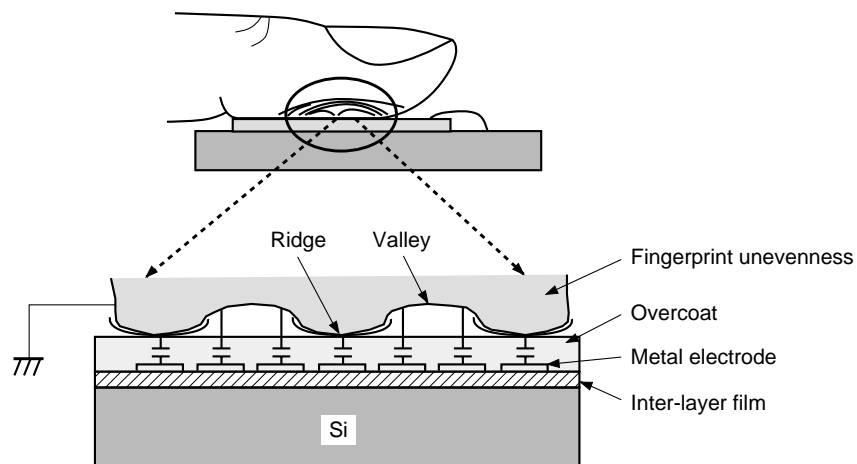

Fig. 1

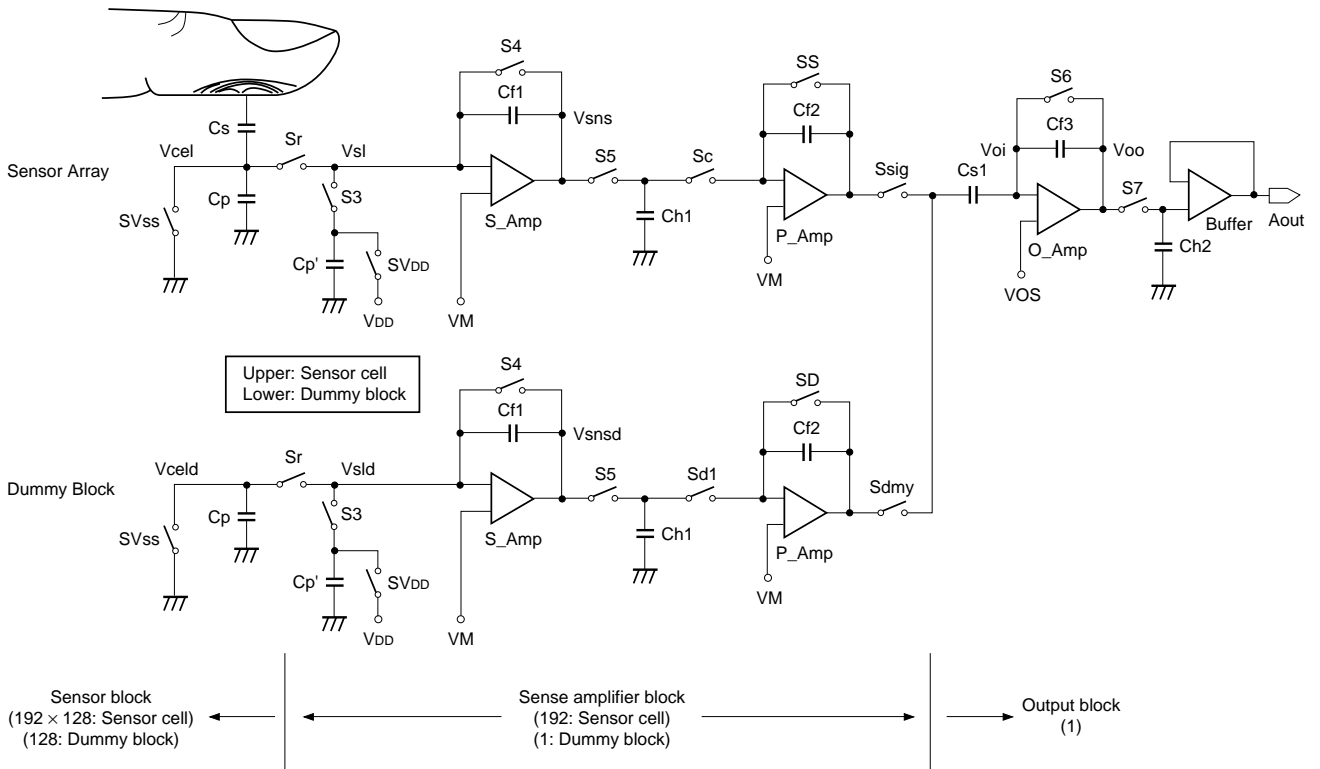

Fig. 2

• Fingerprint sensor operation (Fig. 2)

Description of characters

C_s: Capacitance formed between the finger and the metal electrode

C_p: Parasitic capacitance formed between the metal electrode and the silicon substrate

C_{p'}: Capacitance for canceling C_p (C_p ≈ C_{p'})

Ch*: Hold capacitance

Cf*: Feedback capacitance for determining the gain

S*: Switch

V*: Node voltage

$$V_M = \frac{1}{2} V_{DD}, V_{OS} = \frac{4}{11} V_{DD}$$

Appearance and Readout Order

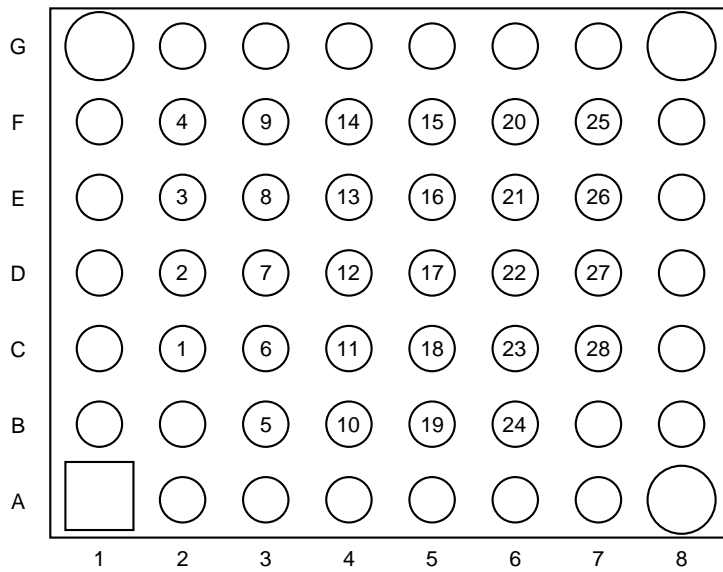
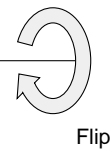
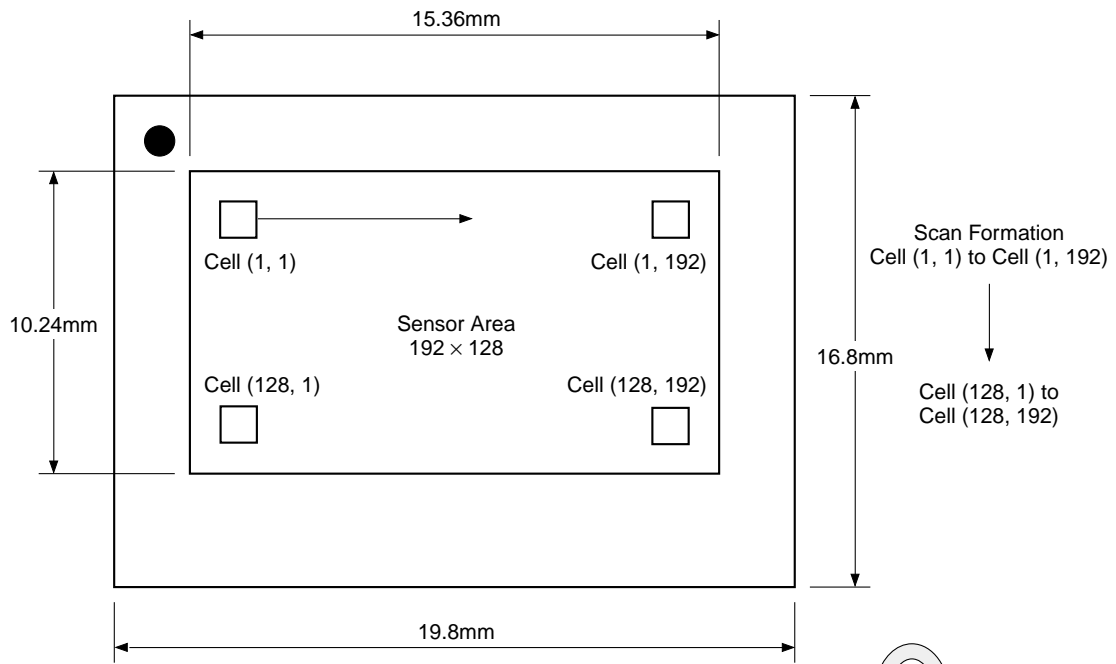

Notes on Operation

Sensor surface electrostatic strength

Aerial discharge (150pF, 330Ω): ±12kV or more

Sony conducts tests using the 50% flash-over method* from the viewpoint of reproducibility and comparison of performance. This method allows more stable measurement than the general method of approaching a discharge gun (approach method). However the discharge distance tends to be longer than for the approach method, so the above performances may not be satisfied if testing is performed by the approach method.

*The discharge distance (distance between the probe tip and the test piece) is determined, and a trigger is applied at fixed time intervals to raise the applied voltage and start discharge. The applied voltage when discharge occurs at just 1/2 of the number of trigger times is the 50% flash-over voltage. The flash-over voltage changes when the distance is changed, but it has been confirmed that there are no problems in terms of sensor performance up to ±12kV.

Sensor surface strength

The sensor surface may be broken by the contact of the metal and others.
Therefore, be sure to pay the sufficient attention to handling this IC.

*Never handle sensors with metal tweezers or similar tools on mounting lines, etc.

Timing Chart

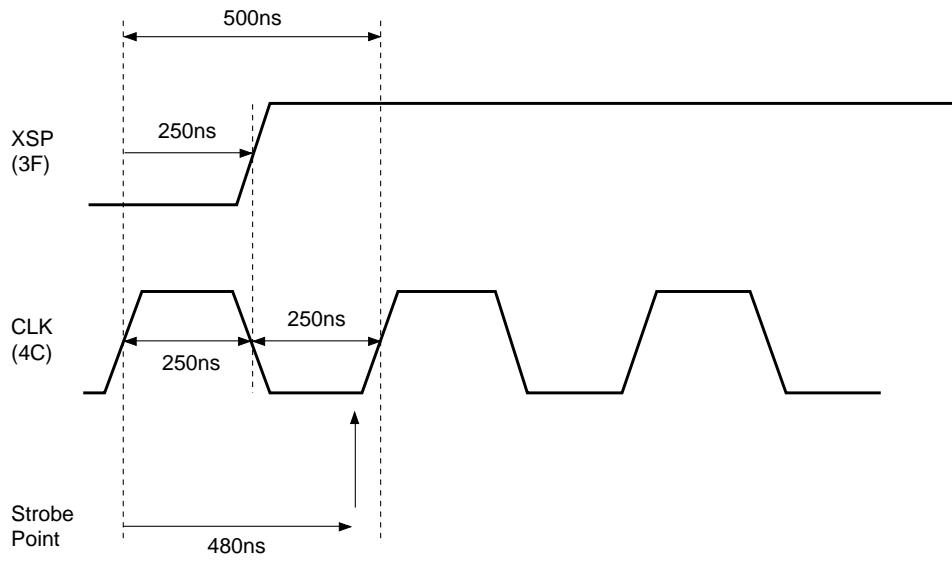

Input level

$V_{IH} = 0.7V_{DD}$
 $V_{IL} = 0.3V_{DD}$

Output level

	High
$0.65V_{DD}$	-----
	X
$0.35V_{DD}$	-----
	Low

Input/Output Signal

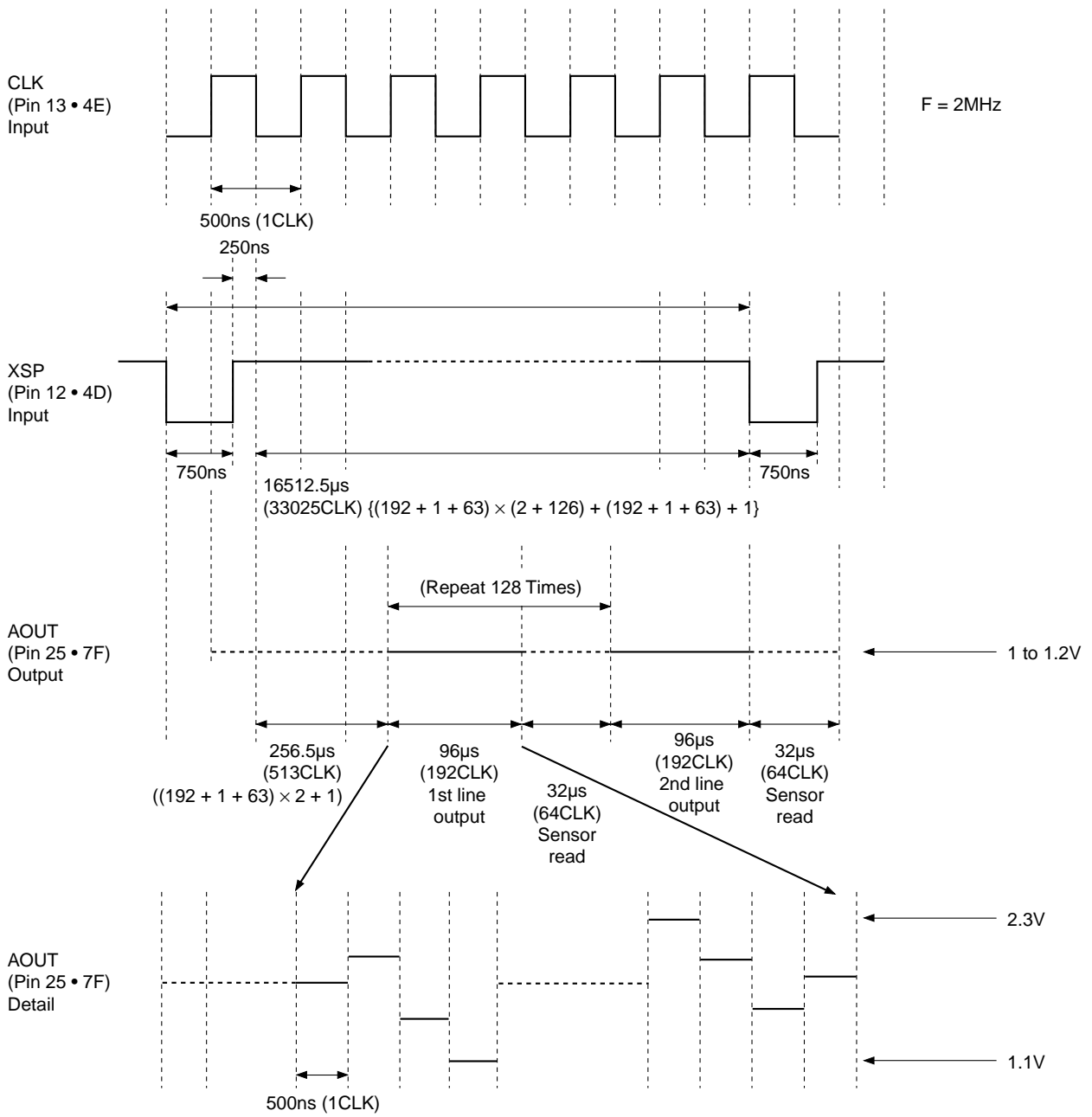

Package Outline Unit: mm

30PIN LLGA

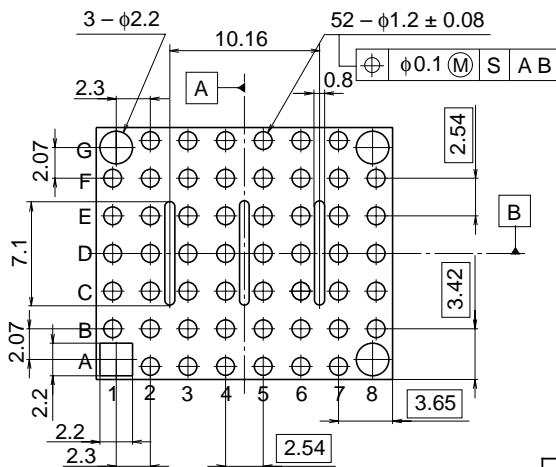
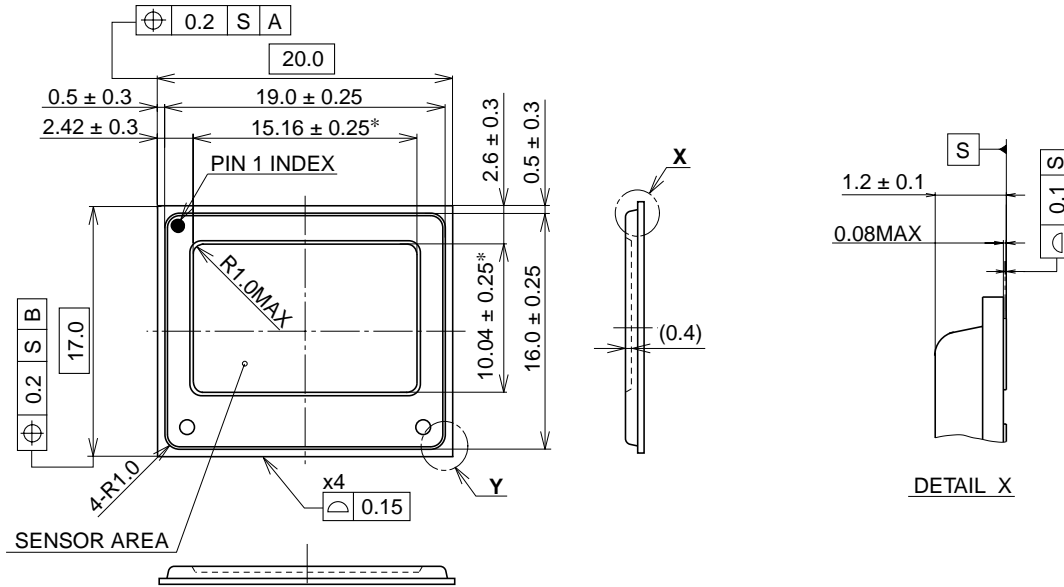

NOTE : * Not include flash burr.

SONY CODE	LLGA-30P-02
JEITA CODE	_____
JEDEC CODE	_____

PACKAGE STRUCTURE

PACKAGE MATERIAL	ORGANIC SUBSTRATE
TERMINAL TREATMENT	NICKEL & GOLD PLATING
TERMINAL MATERIAL	COPPER
PACKAGE MASS	0.7g



LittleDiode supplies new, hard to find or obsolete electronic components and semiconductors all over the world.

With over two million different components listed you are sure to find the part you need.

Feel free to visit us today at our online store:

LittleDiode.com

Looking forward to providing you with the best possible service.