

2ch. Read/Write Amplifier for Thin Film Head of Hard Disk Drive

Description

The CXA3188N is a Read/Write Amplifier for the thin film head of hard disk drive and designed to handle up to 2 channel heads.

Features

- Operate on single +5 V power supply
- Low power consumption
 - Read : 90 mW
 - Write : 115 mW + $I_w \times 5$
 - Idle : 8 mW
- Designed for two terminal thin-film or MIG heads.
- Read amplifier emitter follower output featuring 200 times gain(typ).
- Differential input capacitance for Read : 6pF (typ)
- Input noise : $0.47 \text{ nV} / \sqrt{\text{Hz}}$ (typ)
- Write current range : 10 to 20 mA
- Differential Head voltage swing : 9 Vp-p (typ)
- Differential P-ECL write data input.
- Built-in write unsafe detection circuit.
- Built-in Servo write function.
- Read data outputs are high impedance in write mode.
- Unselected head voltage is high impedance.
- Self switching damping resistor 380Ω .
- Built-in supply voltage monitor circuit prohibits incorrect write during power on or abnormal voltage.

Function

Read, Write and Write unsafe detection for HDD, power supply ON/OFF detection.

Structure

Bipolar silicon monolithic IC

16 pin SSOP (Plastic)

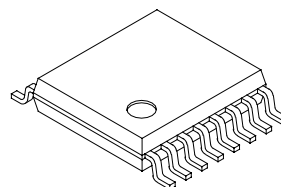

Absolute Maximum Ratings (Ta=25 °C)

• Supply voltage	V _{CC}	6	V
• Operating temperature	T _{opr}	-20 to +70	°C
• Storage temperature	T _{stg}	-55 to +150	°C
• Allowable power dissipation (on board)	P _D	760	mW
• Write current	I _w	22	mA
• WUS/SE pin input current	I _{SEH}	15	mA

Operating Conditions

Supply voltage	V _{CC}	5±0.5	V
----------------	-----------------	-------	---

Sony reserves the right to change products and specifications without prior notice. This information does not convey any license by any implication or otherwise under any patents or other right. Application circuits shown, if any, are typical examples illustrating the operation of the devices. Sony cannot assume responsibility for any problems arising out of the use of these circuits.

Block Diagram and Pin Configuration

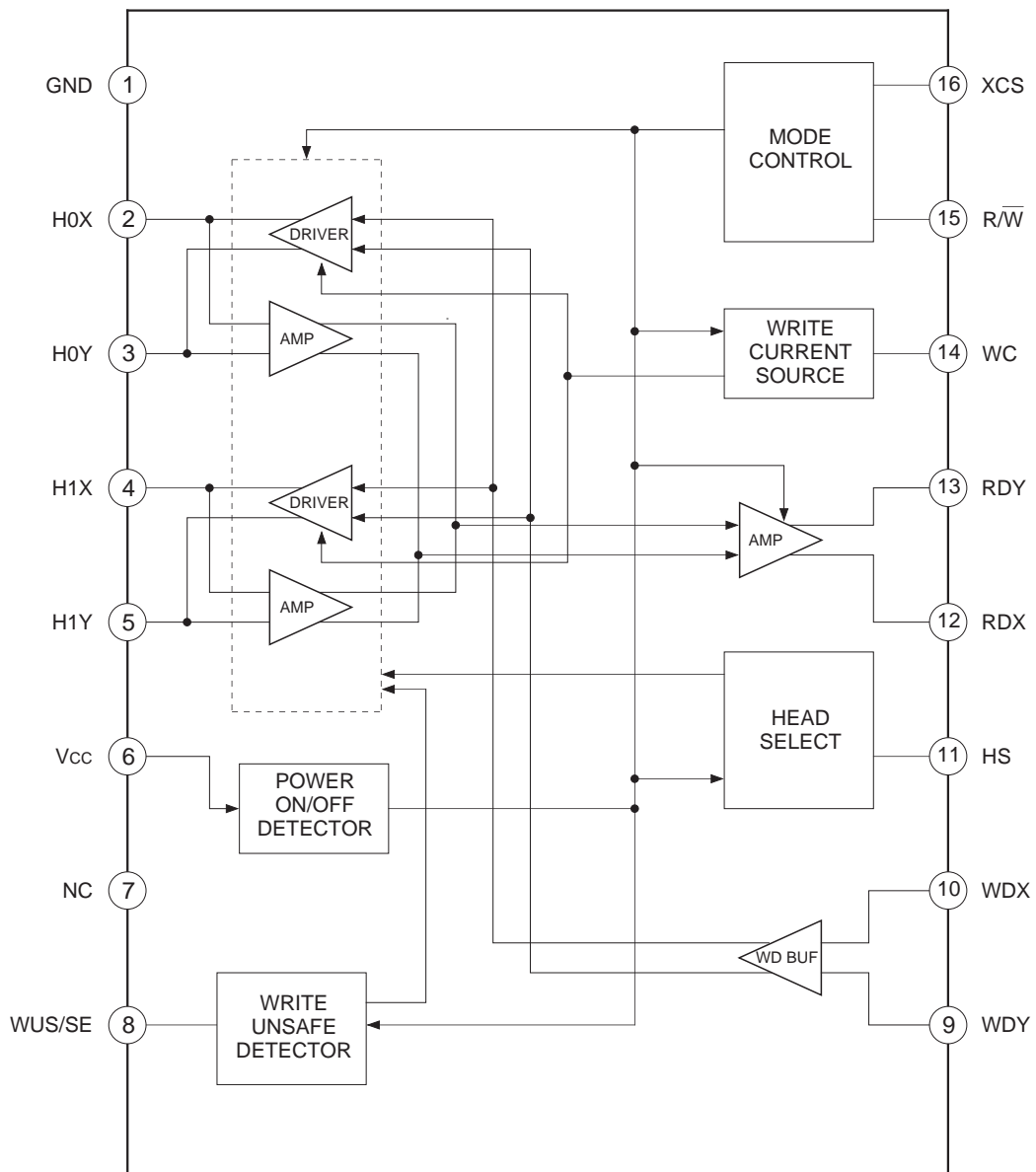

Pin Description

No.	Symbol	Equivalent circuit	Description
1	GND		
2 3 4 5	H0X H0Y H1X H1Y		Head. 2 channels provided.
6	Vcc		5 V power supply.
7	NC		
8	WUS/SE		Write unsafe detection output / Servo Enable signal input.
9 10	WDY WDX		Differential P-ECL write data input.

No.	Symbol	Equivalent circuit	Description
11	HS		<p>Head select signal input. At "Low" : Head0 at "High" : Head1</p>
12 13	RDY RDX		<p>Read amplifier output.</p>
14	WC		<p>A setting resistor for the write current value is connected between this pin and GND.</p>
15	R/W		<p>Read/Write signal input. At "High" : Read at "Low" : Write</p>
16	XCS		<p>Power save signal input At "High" : Power saving.</p>

Electrical Characteristics (Unless otherwise specified, $V_{CC}=5\text{ V}$, $T_a=25\text{ }^\circ\text{C}$, Write current $I_w=20\text{ mA}$)

Item	Symbol	Test condition	Min.	Typ.	Max.	Unit.
Current consumption for read	I_{CCR}		11	18	25	mA
Current consumption for write	I_{CCW}	$I_w=20\text{ mA}$	14 + I_w	23 + I_w	33 + I_w	mA
Current consumption for idle	I_{CCI}		1.1	1.6	2.1	mA
Digital input "Low" input voltage	V_{IL}				0.8	V
Digital input "High" input voltage	V_{IH}		2.0			V
Digital input "Low" input current	I_{IL}	"H" applied voltage: 5 V	-100			μA
Digital input "High" input current	I_{IH}	"L" applied voltage: 0 V			100	μA
Write data input current	I_{WD}				50	μA
Write data input voltage range	V_{WDV}		$V_{CC}-2.5$		V_{CC}	V
WD input amplitude	V_{WDA}		0.3		1	V
Power supply ON/OFF detector threshold voltage	V_{TH}		3.4	3.9	4.3	V
Write current setting range	I_w		10		20	mAo-p
Write current voltage	V_{WC}		2.25	2.5	2.75	V
Write current gain	A_w	$I_w=A_w \cdot V_{WC}/R_{WC}$	18	20	22	mA/mA
Write current setting constant	K_w	When write current is " $I_w[\text{mA}]$ ", $I_w=K_w/R_{WC}$. ($R_{WC}=3.3\text{ k}\Omega$)	46	51	56	
Write unsafe output leak current	I_{WUS}				50	μA
Write unsafe output Low voltage	V_{WUSL}	Output current: 1 mA			0.5	V
WUS/SE input current	I_{SEH}	Servo write Enabled	5		14	mA
WUS/SE High input voltage	V_{SEH}	Servo write Enabled	V_{CC} +1.5		V_{CC} +1.6	V

Item	Symbol	Test condition	Min.	Typ.	Max.	Unit.
Read amplifier differential voltage gain	A_v	Input voltage: 1 mVp-p, 300 kHz load resistor: (RDX, RDY) 1 k Ω	170	200	230	V/V
Frequency band width	Bw1	Frequency at which A_v lower by 1dB	35	60		MHz
	Bw2	Frequency at which A_v lower by 3dB	75	120		MHz
Input referred noise voltage	E_N	Head impedance: 0 Ω		0.47	0.65	$\frac{nV}{\sqrt{Hz}}$
Common mode rejection ratio	CMRR	Common input voltage: 100 mVp-p, 20 MHz	50			dB
Supply voltage rejection ratio	PSRR	Ripple voltage: 100 mVp-p, 20 MHz	50			dB
Channel Separation	CS	Selected head input voltage: 0 mVp-p Unselected head input voltage: 100 mVp-p, 20 MHz	50			dB
Read data output offset voltage for Read	V_{OFF}		-300		300	mV
RDX, RDY common mode output voltage difference between modes	V_{diff}	$C_{RD}=0.1 \mu$	-300		300	mV
RDX, RDY common mode output voltage for Read	V_{RD}			V_{CC} -2.3		V

Unless otherwise specified, $V_{CC}=5$ V, $T_a=25$ °C, f_{WD} (Write data frequency) =5 MHz, $I_w=15$ mA, L_H (Head inductance) =1 μ H, R_H (Head DC resistance value) =30 Ω

Item	Symbol	Measurement conditions	Min.	Typ.	Max.	Unit.
Head differential voltage amplitude	V_{SW}	Differential voltage between HX pin and HY pin at switching of Write current		9		Vp-p
Mode switching time Read to Write	T_{RW}	T_{RW} is the time required for Write current to turn to 90 % after Pin 15 changes from "High" to "Low".		0.13	0.3	μ s
Mode switching time Write to Read	T_{WR1}	T_{WR1} is the time required for the Read amplifier output* to turn to 90 % after Pin 15 changes from "Low" to "High".		0.2	0.3	μ s
	T_{WR2}	T_{WR2} is the time required for Write current to decrease to 10 % after Pin 15 changes from "Low" to "High".		0.1	0.3	μ s
Mode switching time Power saving to Read	T_{IR}	T_{IR} is the time required for the Read amplifier output* to turn to 90 % after Pin 16 changes from "High" to "Low".			1	μ s
Mode switching time safe to unsafe	T_{SA1}	T_{SA1} is the time required for Pin 8 to turn "High" after the last transition of Write data when Write data is stopped in Write mode.	1.0	2.3	3.0	μ s
Mode switching time unsafe to safe	T_{SA2}	T_{SA2} is the time required for Pin 8 to turn "Low" after the first transition of Write data in Write mode.			0.6	μ s
Head switching time	T_H	T_H is the time required for the Read amplifier output* to reach 90 % when the selected head switched in Read mode.			0.6	μ s
Write current propagation delay time	T_{PD}	T_{PD} is the time required for Write current to reach 90 % after the Write data falling edge.		2	7	ns
Write current rise/fall time	T_R/T_F	T_R is the time required for Write current to reach 90 % from 10 %; T_F is the same time required to reach 10 % from 90 %. $L_H=0$ μ H, $R_H=0$ Ω		1	3	ns

*Read amplifier output 100 mVp-p 10 MHz

Timing Chart 1

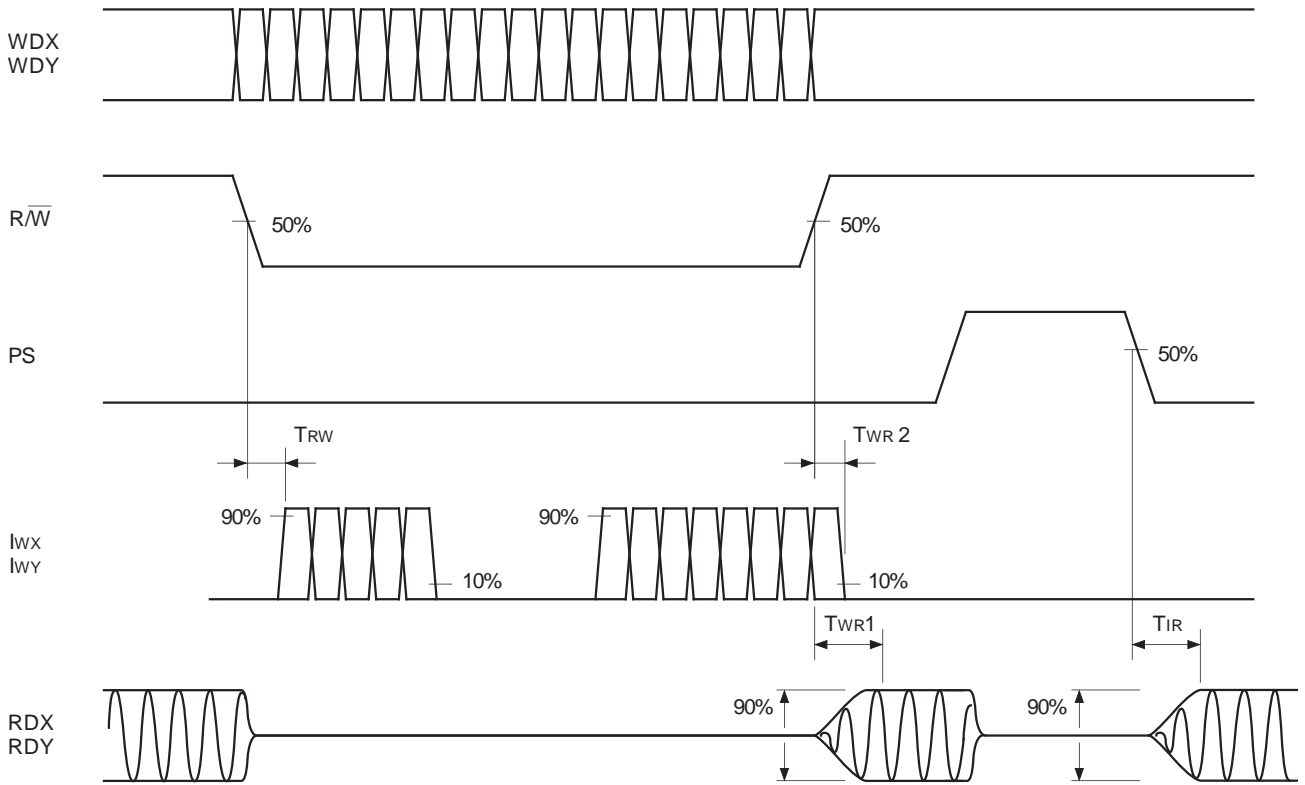

Fig. 3

Timing Chart 2

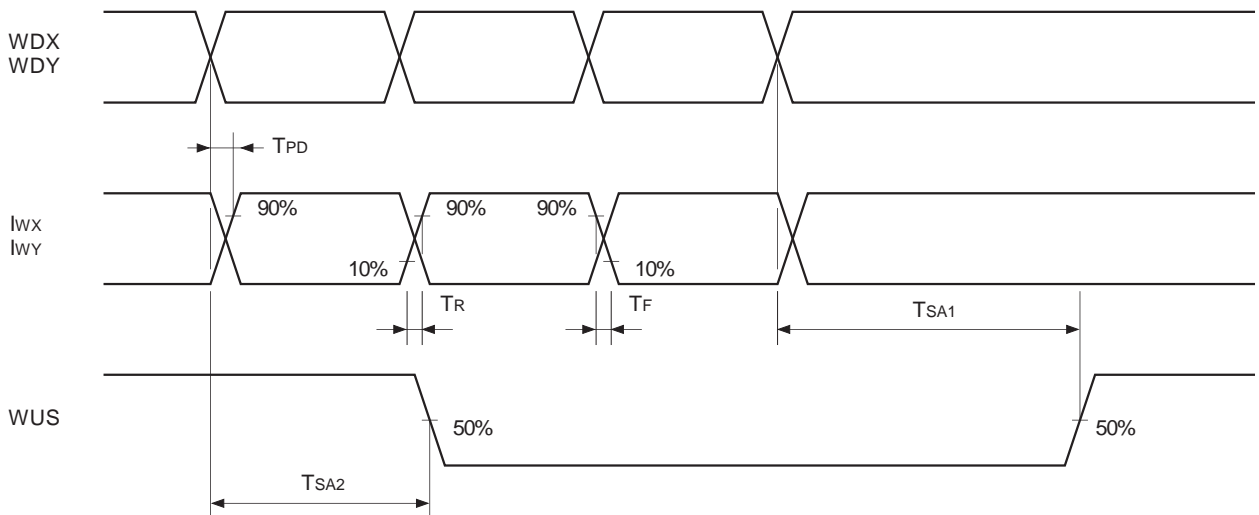

Fig. 4

Description of Functions

Read amplifier

This is a low noise amplifier for amplifying the signals from the heads with an emitter follower output.

The RDX and RDY are the outputs of the differential amplifier, the X side of the head input and RDX pin and the Y side of the head inputs and RDY pin have the same polarity.

Write circuit

The Write data input to WDX pin and WDY pin passes through the buffer amp. It drives the Write switch circuit which supplies the Write current to the heads.

The Write current flows into the X side when WDX is "Low" and WDY is "High".

Mode control

The mode are set as shown Table 1 by $\overline{R/W}$ and WUS/SE.

\overline{CS}	$\overline{R/W}$	WUS/SE	Mode
L	L	X	Write
L	H	X	Read
L	L	**	Servo Write
H	X	X	Power Save

Table 1. Mode selection

Servo write mode **

This mode allows for writing to multiple channels at once. In this mode the write driver will drive all channels simultaneously.

To enable servo write mode follow these steps:

- (1) Place the device in the Read mode.
- (2) Set WUS/SE to V_{SEH} volts, or input I_{SEH} to WUS/SE.
- (3) Initiate the write operation by setting $\overline{R/W}$ Low.

Write unsafe detection circuit

This circuit detects write errors.

In normal Write mode, the WUS output is low; in the conditions listed below, it is high.

- Head input is open (under the condition which $R_H = \infty$ and Write data frequency is ≤ 10 MHz)
- Head input is shorted to GND or V_{CC} .
- Write data frequency is abnormally low.
- No Write current.
- In read mode.
- Supply voltage is abnormal (see "power supply ON/OFF detection").

Power supply ON/OFF detection

This circuit monitors V_{CC} to detect erroneous Writes. The error status is established when V_{CC} falls below the threshold voltage (V_{TH}) of the power supply ON/OFF detector, in which case the recording and playback functions are prohibited. When V_{CC} rises above, V_{TH} , the prohibition of these functions is released.

Application Circuit

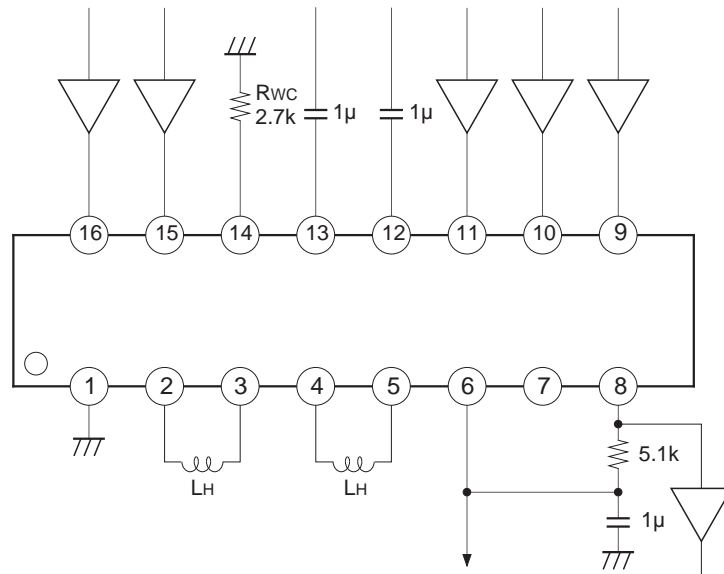

Application circuits shown are typical examples illustrating the operation of the devices. Sony cannot assume responsibility for any problems arising out of the use of these circuits or for any infringement of third party patent and other right due to same.

Notes on operation

- This device handles high frequency and high gain signals. Please note the following;
 - ◆ Connect V_{CC} decoupling capacitor of approximately 1000 pF near the device.
 - ◆ Make the GND area as large as possible.
- The WC pin is a constant voltage pin. When noise affects this pin, it creates noise in Write current. Therefore, locate R_{wc} as close to the device as possible.
- Write unsafe detection circuit
This circuit uses the voltage waveforms of the head pins for detection.

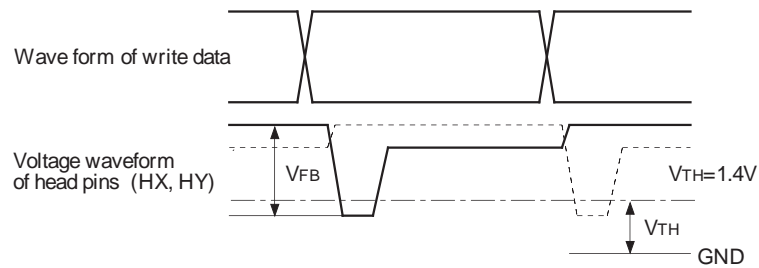

- ◆ V_{FB} must be more than 2 V. When $V_{FB} < 2 V$, it is possible that Write unsafe detection maximum frequency becomes more than 1 MHz.
- ◆ The normal operating area of write unsafe detection circuit is changed by head inductance, head DC resistance, write current and other.

Application Notes

Use the following characteristics for reference

V_{CC}=5 V, T_a=25 °C

Item		Symbol	Condition	Min.	Typ.	Max.	Unit
Write mode	Differential output capacitance	C _O	Between head input pins		4.5	6	pF
	Differential output resistance	R _D		250	380	490	Ω
Read mode	Differential input capacitance	C _I	Between head input pins f=5MHz		6	10	pF
	Differential input resistance	R _I		0.4	1.2		kΩ
	Output resistance	R _{RD}	RDX or RDY, f=5MHz		45	60	Ω
Unselected head differential current at write mode		I _{US}	L _H =2 μH, R _H =30 Ω I _W =15 mA			0.2	mAp-p
Write current symmetry		T _{ASY}	L _H =0 μH, R _H =0 Ω I _W =15 mA	-0.5		0.5	ns

*T_{AS}=T₁-T₂

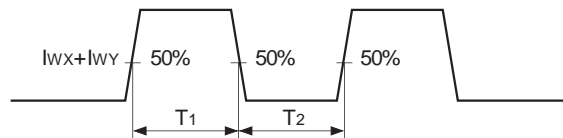

Setting of Write current

Write current can be set with resistor R_{wc} (kΩ) at Pin 14.

I_w=K/R_{wc} (mA) Refer to Fig. 5.

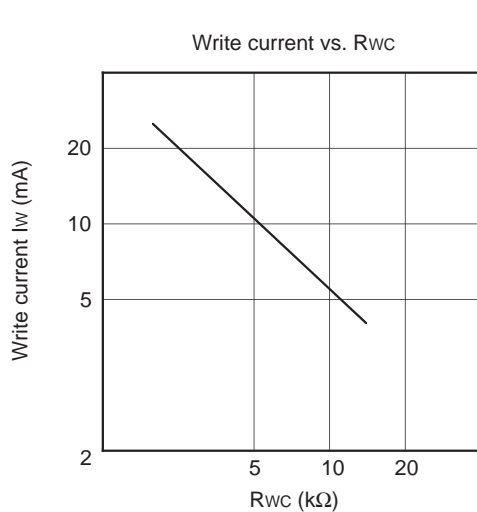

Fig. 5

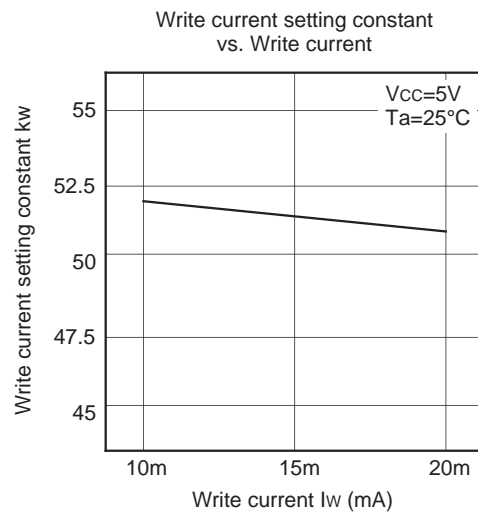
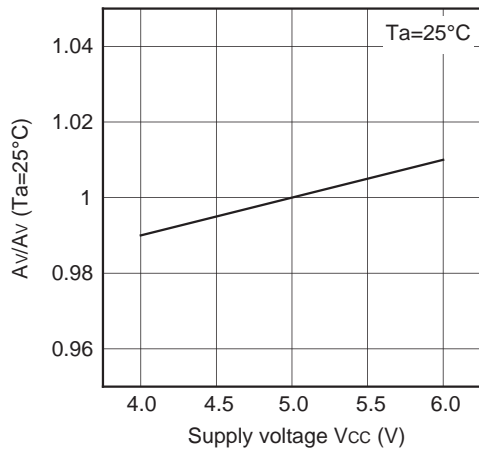
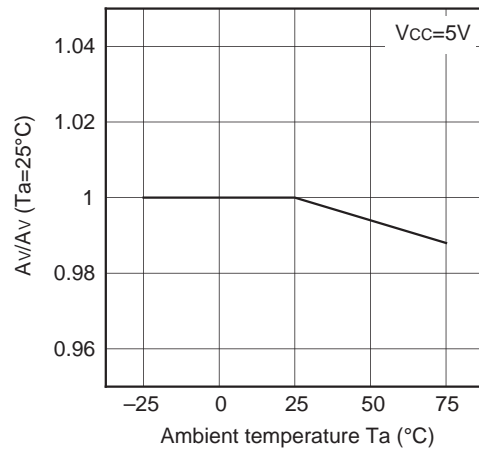

Fig. 6

Normalized read amplifier voltage gain vs. Supply voltage



Normalized read amplifier voltage gain vs. Ambient temperature



Normalized write current vs. Supply voltage

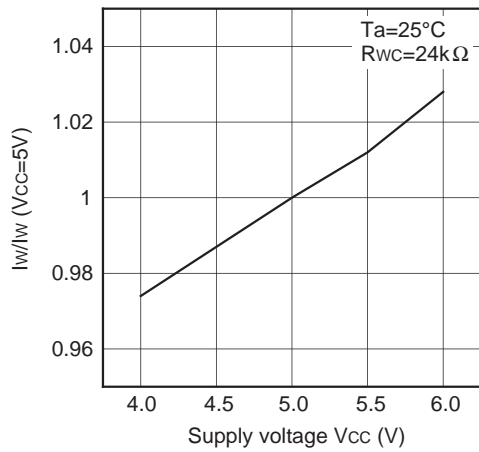

Normalized write current vs. Ambient temperature

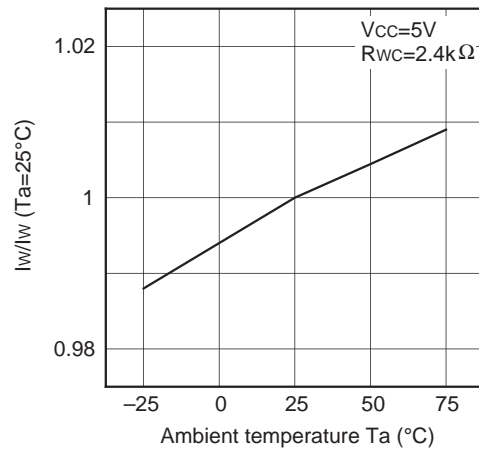

Input referred noise voltage vs. Supply voltage

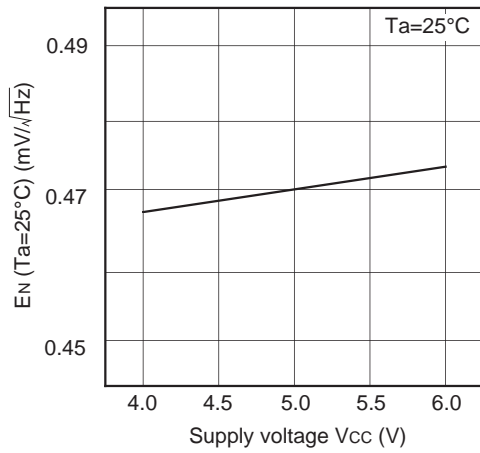

Input referred noise voltage vs. Ambient temperature

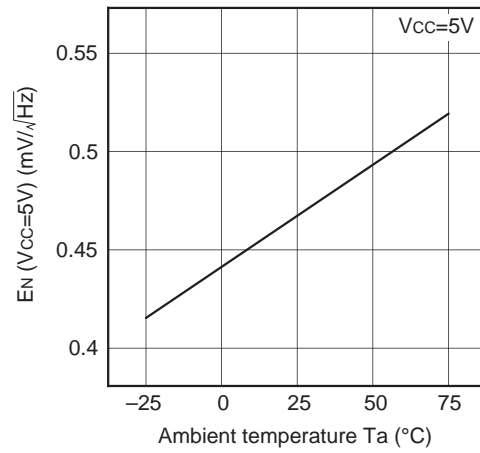

Power supply ON/OFF detector threshold voltage vs. Ambient temperature

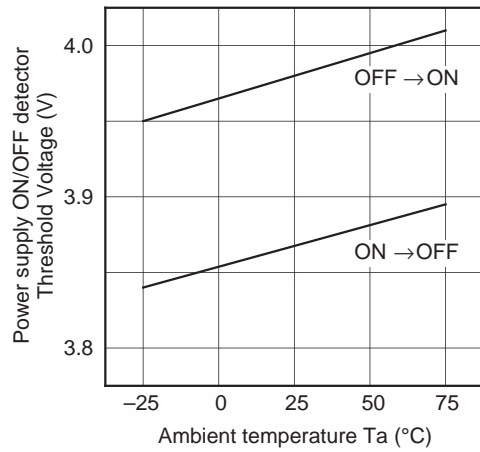

Package Outline Unit : mm

16PIN SSOP (PLASTIC)

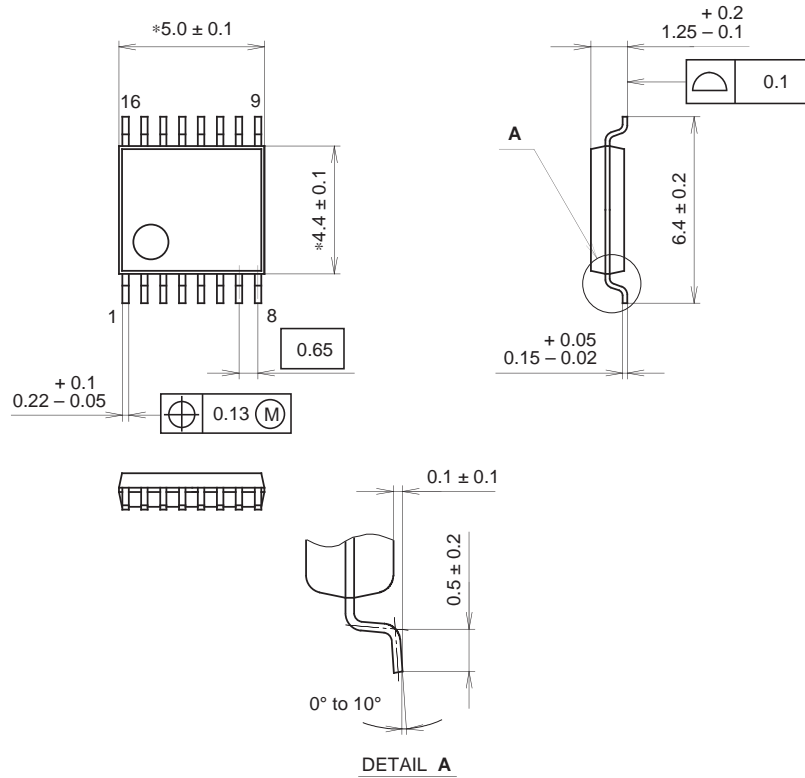

NOTE: Dimension "*" does not include mold protrusion.

PACKAGE STRUCTURE

SONY CODE	SSOP-16P-L01
EIAJ CODE	SSOP016-P-0044
JEDEC CODE	_____

PACKAGE MATERIAL	EPOXY RESIN
LEAD TREATMENT	SOLDER / PALLADIUM PLATING
LEAD MATERIAL	42/COPPER ALLOY
PACKAGE MASS	0.1g

NOTE : PALLADIUM PLATING
 This product uses S-PdPPF (Sony Spec.-Palladium Pre-Plated Lead Frame).



LittleDiode supplies new, hard to find or obsolete electronic components and semiconductors all over the world.

With over two million different components listed you are sure to find the part you need.

Feel free to visit us today at our online store:

LittleDiode.com

Looking forward to providing you with the best possible service.