

L-band Down Converter IC with On-Chip PLL

Description

The CXA3108AQ is a monolithic IC that down-converts the L-band (1 to 2 GHz) 1st IF to 2nd IF for satellite broadcast receivers. It integrates a local oscillator circuit, double-balanced mixer, IF AGC amplifier and tuning PLL onto a single chip.

This IC supports both analog and digital satellite broadcasts, and achieves reduction in the number of tuner components and smaller size.

Features

- On-chip tuning PLL
- Supports 2.65 GHz oscillator frequency
- Noise figure: 12.5 dB typ. (for IF full gain)
- IF AGC gain variation: 46 dB typ.
- Wide band IF AGC amplifier (60 to 500 MHz)
- Two IF outputs
- PLL supports I²C protocol
- On-chip high voltage drive transistor for charge pump

Applications

- Analog satellite broadcast tuners (BS/CS)
- Digital satellite broadcast tuners (DSS/DVB, etc.)

Structure

Bipolar silicon monolithic IC

40 pin QFP (Plastic)

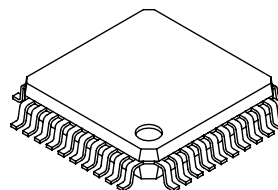
**Absolute Maximum Ratings** (Ta=25 °C)

- Supply voltage V_{CC} -0.3 to +5.5 V
- Storage temperature T_{stg} -55 to +150 °C
- Allowable power dissipation P_D 730 mW
(when mounted on a substrate)

Operating Conditions

- Supply voltage V_{CC} 4.75 to 5.30 V
- Operating temperature T_{opr} -25 to +75 °C

Notes on Handling

This IC has a weak electrostatic discharge strength. Take care when handling the IC.

Sony reserves the right to change products and specifications without prior notice. This information does not convey any license by any implication or otherwise under any patents or other right. Application circuits shown, if any, are typical examples illustrating the operation of the devices. Sony cannot assume responsibility for any problems arising out of the use of these circuits.

Block Diagram and Pin Configuration

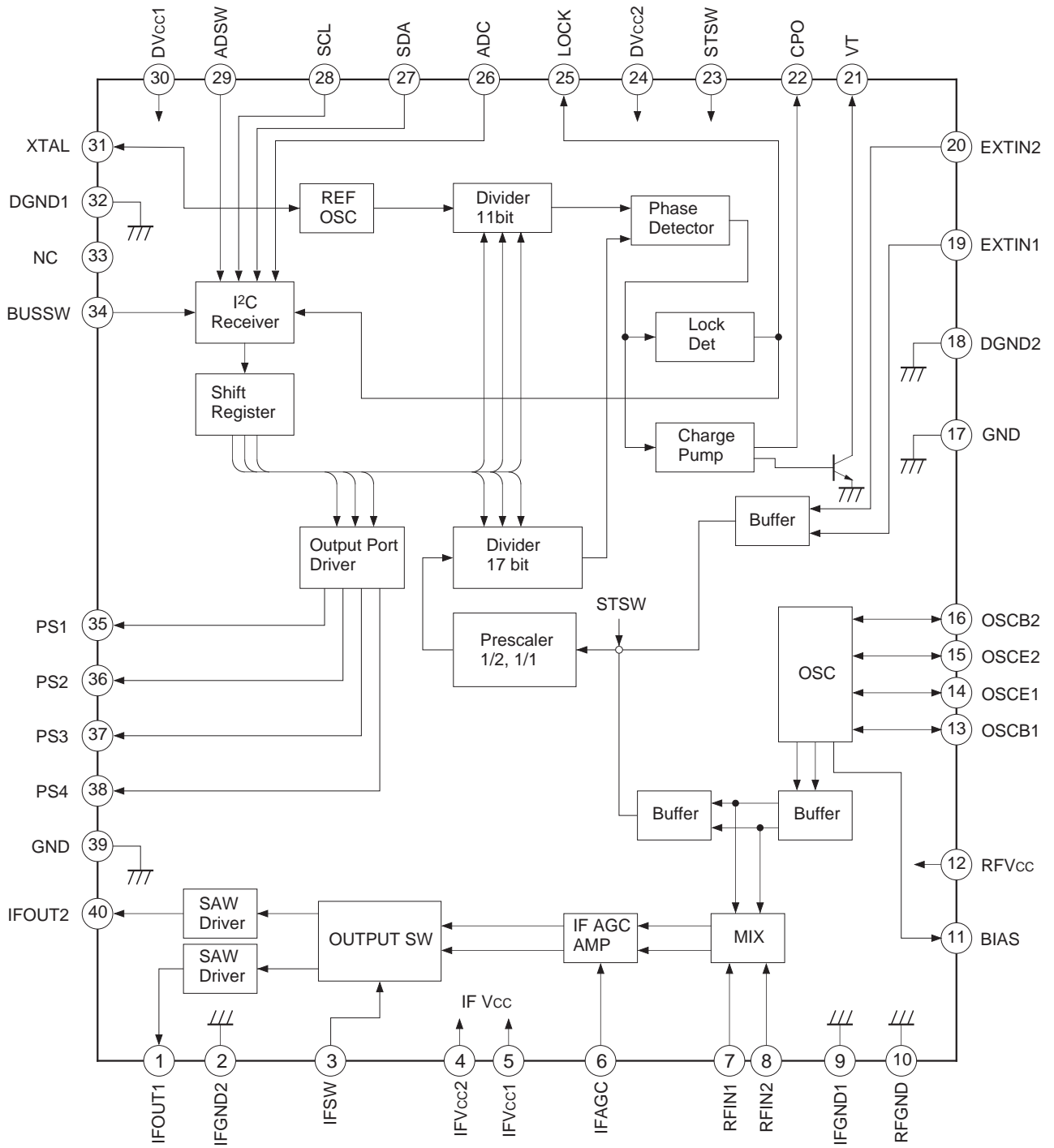

Pin Description

| Pin No. | Symbol | Pin voltage [V] | Equivalent circuit | Description |
|---------|--------|--|--------------------|---|
| 1 | IFOUT1 | 2.5 (IFSW 0 V) 4.7 (IFSW 5 V) | | IF outputs. |
| 40 | IFOUT2 | 4.7 (IFSW 0 V) 2.5 (IFSW 5 V) | | |
| 2 | IFGND2 | 0 | | IF output circuit GND. |
| 3 | IFSW | 0 or 5 | | Selects whether IF output is Pin 1 or Pin 40. When this pin is connected to GND, the IF signal is output from Pin 1; when connected to Vcc, the IF signal is output from Pin 40. |
| 4 | IFVcc2 | 5 | | IF output circuit power supply. |
| 5 | IFVcc1 | 5 | | IF amplifier circuit power supply. |
| 6 | IFAGC | 0 to 4 | | AGC signal input. |
| 7 | RFIN1 | 1.7 | | RF inputs. |
| 8 | RFIN2 | 1.7 | | |
| 9 | IFGND1 | 0 | | IF amplifier circuit GND. |
| 10 | RFGND | 0 | | RF block GND. |

| Pin No. | Symbol | Pin voltage [V] | Equivalent circuit | Description |
|---------|--------|-----------------|--------------------|--|
| 11 | BIAS | 1.8 | | Oscillator circuit current adjustment. Connect this pin to GND via a capacitor. |
| 12 | RFVcc | 5 | | RF block power supply. |
| 13 | OSCB1 | 2.2 | | Oscillator pins. |
| 14 | OSCE1 | 1.5 | | |
| 15 | OSCE2 | 1.5 | | |
| 16 | OSCB2 | 2.2 | | |
| 17 | GND | 0 | | GND. |
| 18 | DGND2 | 0 | | Charge pump GND. |
| 19 | EXTIN1 | 2.5 | | PLL external inputs. |
| 20 | EXTIN2 | 2.5 | | |
| 21 | VT | — | | NPN transistor output for varicap diode drive. |
| 22 | CPO | — | | Charge pump output. Connect a loop filter. |

| Pin No. | Symbol | Pin voltage [V] | Equivalent circuit | Description |
|---------|--------|----------------------------|--------------------|---|
| 23 | STSW | — | | <p>Selects either the internal oscillator circuit or external input for input to PLL.</p> <p>When this pin is open or connected to Vcc, the internal oscillator circuit is selected; when connected to GND, external input is selected.</p> |
| 24 | DVcc2 | 5 | | Charge pump power supply. |
| 25 | LOCK | 5.0 (LOCK) 0.2 (UNLOCK) | | <p>LOCK detection.</p> <p>High when locked, Low when unlocked.</p> |
| 26 | ADC | — | | ADC input. |
| 27 | SDA | — | | DATA input. |

| Pin No. | Symbol | Pin voltage [V] | Equivalent circuit | Description |
|---------|--------|-----------------|--------------------|--|
| 28 | SCL | — | | CLOCK input. |
| 29 | ADSW | 1.3 | | I ² C bus address selection. |
| 30 | DVcc1 | 5 | | PLL circuit power supply. |
| 31 | XTAL | 4.4 | | Crystal connection for reference oscillator. |
| 32 | DGND1 | 0 | | PLL circuit GND. |
| 33 | NC | — | | |

| Pin No. | Symbol | Pin voltage [V] | Equivalent circuit | Description |
|---------|--------|-----------------------------|--|--|
| 34 | BUSSW | — | <p>The diagram shows a circuit with two diodes. The top diode has its anode at pin 30 and its cathode at pin 34. The bottom diode has its anode at pin 34 and its cathode connected to ground (GND). A transistor is connected with its emitter to GND, its base to pin 34, and its collector to DVcc1 through a resistor. Another resistor is connected between DVcc1 and pin 30.</p> | PLL circuit GND. Connect directly to GND. |
| 35 | PS1 | 5.0 (OFF) 0.2 (ON) | <p>The diagram shows a complex circuit with multiple transistors, diodes, and resistors. It is connected to DVcc1 and ground. The circuit includes a transistor with its emitter to GND and collector to DVcc1. Another transistor has its base connected to DVcc1 through a resistor and its emitter to GND. There are several diodes and resistors connected to pins 30, 35, 36, 37, and 38.</p> | Output ports. |
| 36 | PS2 | | | |
| 37 | PS3 | | | |
| 38 | PS4 | | | |
| 39 | GND | 0 | | GND. |

Electrical Characteristics

(V_{CC}=5 V, T_a=25 °C)

Circuit Current

| Item | Symbol | Measurement conditions | Min. | Typ. | Max. | Unit |
|-------------------|------------------|---|------|------|------|------|
| Circuit current A | AI _{CC} | Analog circuit current Sum of RFV _{CC} , IFV _{CC} 1 and IFV _{CC} 2 currents | 42 | 62 | 82 | mA |
| Circuit current D | DI _{CC} | PLL circuit current Sum of DV _{CC} 1 and DV _{CC} 2 currents | 18 | 30 | 40 | mA |

OSC/MIX/IF Amplifier Blocks

| Item | Symbol | Measurement conditions | Min. | Typ. | Max. | Unit |
|-------------------------------------|----------------|---|------|------|------|--------|
| Conversion gain | CG1 | f _{in} =950 MHz, f _F =480 MHz IFAGC=4 V (Full Gain) | 15 | 21 | 25 | dB |
| | CG2 | f _{in} =1450 MHz, f _F =480 MHz IFAGC=4 V (Full Gain) | 14 | 20 | 24 | dB |
| | CG3 | f _{in} =2150 MHz, f _F =480 MHz IFAGC=4 V (Full Gain) | 18 | 24 | 28 | dB |
| Noise figure | NF1 | f _{in} =950 MHz, f _F =480 MHz IFAGC=4 V (Full Gain) | | 13 | 16 | dB |
| | NF2 | f _{in} =1450 MHz, f _F =480 MHz IFAGC=4 V (Full Gain) | | 13 | 16 | dB |
| | NF3 | f _{in} =2150 MHz, f _F =480 MHz IFAGC=4 V (Full Gain) | | 13 | 16 | dB |
| IFAGC gain variation range | AGC | | 35 | 50 | | dB |
| IF maximum output | PoSAT | f _F =480 MHz, 50 Ω load saturated output | | 9 | | dBm |
| RF pin local oscillator leak | RFLK1 | f _{osc} =1430 to 1830 MHz | | | -20 | dBm |
| | RFLK2 | f _{osc} =1830 to 2230 MHz | | | -20 | dBm |
| | RFLK3 | f _{osc} =2230 to 2630 MHz | | | -25 | dBm |
| IF pin local oscillator leak | IFLK1 | f _{osc} =1430 to 1830 MHz | | | -18 | dBm |
| | IFLK2 | f _{osc} =1830 to 2230 MHz | | | -18 | dBm |
| | IFLK3 | f _{osc} =2230 to 2630 MHz | | | -20 | dBm |
| Tertiary intermodulation distortion | IM3 | Pin=-25 dBm IFAGC=4 V (Full Gain) f _{in} =935 MHz, 940 MHz f _{out} =475 MHz, 480 MHz S/I of 480 MHz and 475 MHz | 38 | 45 | | dB |
| Local oscillator phase noise | CN1 | f _{osc} =1430 MHz 10 kHz offset | | 80 | | dBc/Hz |
| | CN2 | f _{osc} =1430 MHz 100 kHz offset | | 100 | | dBc/Hz |
| RF input impedance | r _π | f=950 MHz | | 12.9 | | Ω |
| | C _π | f=950 MHz | | 1.84 | | pF |

PLL Block

| Item | Symbol | Measurement conditions | Min. | Typ. | Max. | Unit |
|----------------------------|--------------------|-----------------------------------|------|------|-----------------|------|
| External local input level | EXT | | | -20 | | dBm |
| SDA, SCL | | | | | | |
| High level input voltage | V _{IH} | | 3 | | V _{CC} | V |
| Low level input voltage | V _{IL} | | GND | | 1.5 | V |
| High level input current | I _{IH} | V _{IH} =V _{CC} | | 0 | -0.1 | μA |
| Low level input current | I _{IL} | V _{IL} =GND | | -1 | -2 | μA |
| SDA Low output voltage | L _{SDA} | Sink current=3 mA | | | 0.4 | V |
| Clock input hysteresis | Cl _{HYS} | | 0.25 | 0.4 | 0.65 | V |
| CPO (charge pump) | | | | | | |
| Output current 1 | I _{CPO1} | Byte 4/bit 6=0 and for 3WB | ±35 | ±50 | ±75 | μA |
| Output current 2 | I _{CPO2} | Byte 4/bit 6 | ±125 | ±180 | ±270 | μA |
| ADC | | | | | | |
| Input current | I _{ADC} | Input voltage=5 V | | 0.2 | | μA |
| LOCK | | | | | | |
| High output voltage | V _{LKH} | Load resistance 10 kΩ, for LOCK | | | V _{CC} | V |
| Low output voltage | V _{LKL} | Load resistance 10 kΩ, for UNLOCK | | | 0.5 | V |
| REFOSC | | | | | | |
| Oscillator frequency range | F _{XTOSC} | | 3 | | 12 | MHz |
| Input capacitance | C _{XTOSC} | | | 14 | | pF |
| Drive level | V _{XTOSC} | | | 200 | | mV |
| PS1 to PS4 | | | | | | |
| Pull-in current | Sink _{PS} | When ON | | | 1 | mA |
| Leak current | Leak _{PS} | When OFF | | | 200 | nA |

Bus Timing

| Item | Symbol | Measurement conditions | Min. | Typ. | Max. | Unit |
|----------------------|-------------------|------------------------|------|------|------|------|
| I ² C Bus | | | | | | |
| SCL clock frequency | f _{SCL} | | 0 | | 400 | kHz |
| Start waiting time | t _{WSTA} | | 1300 | | | ns |
| Start hold time | t _{HSTA} | | 600 | | | ns |
| Low hold time | t _{LOW} | | 1300 | | | ns |
| High hold time | t _{HIGH} | | 600 | | | ns |
| Start setup time | t _{SSTA} | | 600 | | | ns |
| Data hold time | t _{HDAT} | | 1300 | | | ns |
| Data setup time | t _{SDAT} | | 600 | | | ns |
| Rise time | t _R | | | | 300 | ns |
| Fall time | t _F | | | | 300 | ns |
| Stop setup time | t _{SSTO} | | 600 | | | ns |

Electrical Characteristics Measurement Circuit

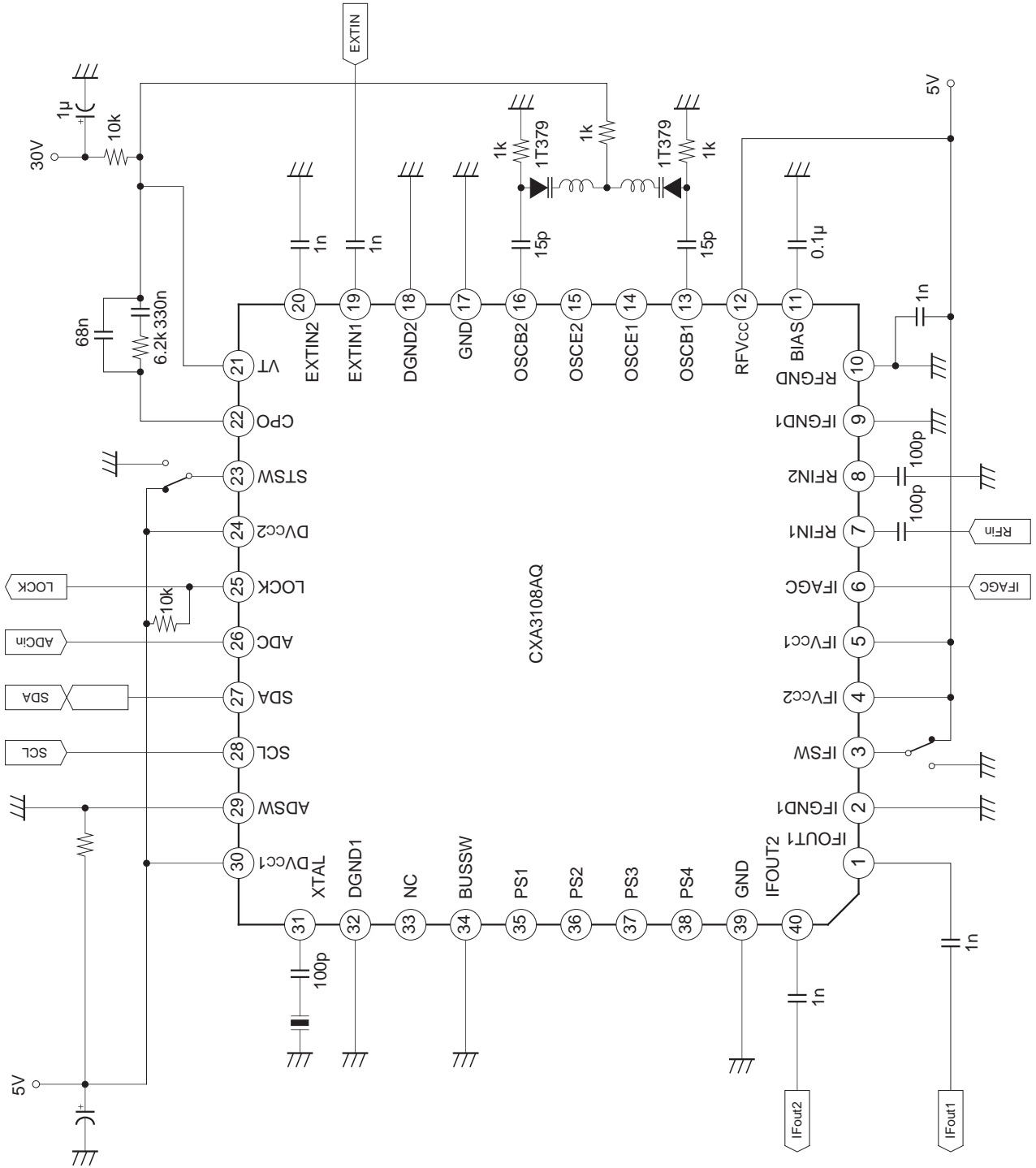

Description of Functions

The CXA3108AQ is a tuner IC for satellite broadcast receivers. It converts the RF signal down-converted to 1st IF (1 to 2 GHz) at the LNB to 2nd IF, so that only the desired reception frequency is selected and detected.

This IC combines the mixer, local oscillator and IF amplifier (variable gain) circuits required for frequency conversion to 2nd IF, and the PLL circuit which controls the local oscillator frequency onto a single chip.

The function of each block is described below.

1. Mixer Circuit

This circuit outputs the frequency difference between the signal input to RF IN and the local oscillator signal. A double-balanced mixer with minimal local oscillator signal leak is used. RF input is equivalent to a differential amplifier with emitter grounding.

2. Local Oscillator Circuit

A Colpitts oscillator with differential operation is used for the oscillator circuit, so it is stable relative to supply voltage fluctuation, and undesired radiation is suppressed. This circuit also contains a capacitor which is part of the resonance circuit, so there is minimal parasitic oscillation and design of external circuits is easier.

3. IF Amplifier Circuit

This circuit amplifies the mixer IF output, and is comprised of an AGC amplifier stage and low impedance output stage.

The gain can be varied by the AGC pin voltage (range 0 to 4 V) at the AGC amplifier stage. The maximum gain is approximately 20 dB (voltage gain between RF IN and IF OUT), and the gain variation width is 30 dB or more.

The output stage has two unbalanced outputs, and can directly connect two SAW filters with different pass bandwidths. Output pin selection is determined by the IF SW pin voltage.

The IF amplifier circuit is a wide band amplifier circuit, and can be used in the IF frequency range of 60 to 500 MHz.

4. PLL Circuit-1 (normal operation: when the STSW pin is open or connected to V_{cc})

The PLL circuit fixes the local oscillator frequency to the desired frequency. It consists of the prescaler, main divider, reference divider, phase comparator, charge pump and reference oscillator. The control format supports the I²C bus protocol.

When the power (DV_{cc1}) is turned on, the power-on reset circuit activates and the frequency division data and control data are all initialized to 0. The power-on reset threshold is 3 V at normal temperature (T_a=25 °C).

5. PLL Circuit-2 (external input PLL operation: when the STSW pin is connected to GND)

When the STSW pin is connected to GND, the PLL enters independent operation mode where the PLL only is used with the oscillator signal input from the external signal input pin.

Description of PLL Block

1. Programming

1-1. The main divider frequency division ratio is obtained according to the following formulas.

$$f_{osc} = f_{ref} \times (16M + S) \text{ or } f_{osc} = f_{ref} \times 2 \times (16M + S) \text{ (when PE = 1)}$$

f_{osc} : local oscillator frequency

f_{ref} : comparison frequency

2 : prescaler fixed frequency division ratio (when PE = 1)

M : main divider frequency division ratio

S : swallow counter frequency division ratio

The variable frequency division ranges of M and S are as follows.

$$S \leq M \leq 4095$$

$$0 \leq S \leq 15$$

During PLL independent operation (STSW = GND), the prescaler halving frequency division cannot be added.

1-2. I²C Bus

This IC conforms to the standard I²C bus format, and bidirectional bus control is possible consisting of a write mode in which various data are received and a read mode in which various data are sent.

Write and read modes are recognized according to the setting of the final bit (R/W bit) of the address byte. Write mode is set when the R/W bit is "0", and read mode is set when the R/W bit is "1".

1-2-1. Address Setting

The responding address can be changed by the ADSW pin voltage to allow more than one PLL in a system.

<Table 1> Address

| ADSW pin voltage | MA1 | MA0 |
|--|-----|-----|
| 0 to 0.1 V _{cc} | 0 | 0 |
| OPEN | 0 | 1 |
| 0.4 V _{cc} to 0.6 V _{cc} | 1 | 0 |
| 0.9 V _{cc} to V _{cc} | 1 | 1 |

1-2-2. Data format

Write mode is used to receive various data. In this mode, byte 1 contains the address data, bytes 2 and 3 contain the frequency data, and bytes 4 and 5 contain the various control data.

These data are latch transferred in the manner of byte 1, byte 2 + byte 3, byte 4, and byte 5. When the correct address is received, the data is recognized as frequency data if the first bit of the next byte is "0", and as control data if this bit is "1".

Also, when data transmission is stopped part-way, the previously programmed data is valid. Therefore, once the control data has been programmed, 3-byte commands consisting of the address and frequency data are possible.

Further, even if the I²C bus stop conditions are not met, data can be input by sending the start conditions and the new address.

In read mode, the power-on reset operation status, phase comparator locked/unlocked status and 5-value A/D converter input pin voltage status are transmitted to the master.

Power-on reset is set to "1" when the supply voltage (DV_{CC1}) power supply is cut off.

If DV_{CC1} is 3 V or higher and the status is output in the read mode, this bit is reset to "0".

Write mode: slave receiver

| | MSB | | | | | | | LSB | | |
|----------------|------|------|------|------|------|------|------|------|---|--|
| MODE | bit7 | bit6 | bit5 | bit4 | bit3 | bit2 | bit1 | bit0 | | |
| Address byte | 1 | 1 | 0 | 0 | 0 | MA1 | MA0 | 0 | A | |
| Divider byte 1 | 0 | M10 | M9 | M8 | M7 | M6 | M5 | M4 | A | |
| Divider byte 2 | M3 | M2 | M1 | M0 | S3 | S2 | S1 | S0 | A | |
| Control byte 1 | 1 | M12 | M11 | PE | R3 | R2 | R1 | R0 | A | |
| Control byte 2 | OS | CP | 0 | 0 | P4 | P3 | P2 | P1 | A | |

Read mode: slave transmitter

| MODE | bit7 | bit6 | bit5 | bit4 | bit3 | bit2 | bit1 | bit0 | |
|--------------|------|------|------|------|------|------|------|------|--|
| Address byte | 1 | 1 | 0 | 0 | 0 | MA1 | MA0 | 1 | |
| Status byte | PR | FL | 1 | 1 | 1 | A2 | A1 | A0 | |

- P1 to P4 : port control
 M0 to M12 : main divider frequency division ratio setting
 S0 to S3 : swallow counter frequency division ratio setting
 OS : varicap output OFF (when "1")
 CP : charge pump current switching
 PE : prescaler halving frequency division added (when "1")
 PR : power-on reset
 FL : lock detection signal
 A0 to A2 : 5-value ADC data (ADC pin voltage conversion: Table 2)
 R0 to R3 : reference divider frequency division ratio selection (Table 3)

<Table 2> ADC Conversion Table

| ADC pin voltage | A2 | A1 | A0 |
|---|----|----|----|
| 0 to 0.15V _{cc} | 0 | 0 | 0 |
| 0.15 V _{cc} to 0.3 V _{cc} | 0 | 0 | 1 |
| 0.3 V _{cc} to 0.45 V _{cc} | 0 | 1 | 0 |
| 0.45 V _{cc} to 0.6 V _{cc} | 0 | 1 | 1 |
| 0.6 V _{cc} to V _{cc} | 1 | 0 | 0 |

<Table 3> Reference Divider Frequency Division Ratio

| R3 | R2 | R1 | R0 | Frequency division ratio |
|----|----|----|----|--------------------------|
| 0 | 0 | 0 | 0 | 2 |
| 0 | 0 | 0 | 1 | 4 |
| 0 | 0 | 1 | 0 | 8 |
| 0 | 0 | 1 | 1 | 16 |
| 0 | 1 | 0 | 0 | 32 |
| 0 | 1 | 0 | 1 | 64 |
| 0 | 1 | 1 | 0 | 128 |
| 0 | 1 | 1 | 1 | 256 |
| 1 | 0 | 0 | 0 | — |
| 1 | 0 | 0 | 1 | 5 |
| 1 | 0 | 1 | 0 | 10 |
| 1 | 0 | 1 | 1 | 20 |
| 1 | 1 | 0 | 0 | 40 |
| 1 | 1 | 0 | 1 | 80 |
| 1 | 1 | 1 | 0 | 160 |
| 1 | 1 | 1 | 1 | 320 |

I²C Bus Timing Chart

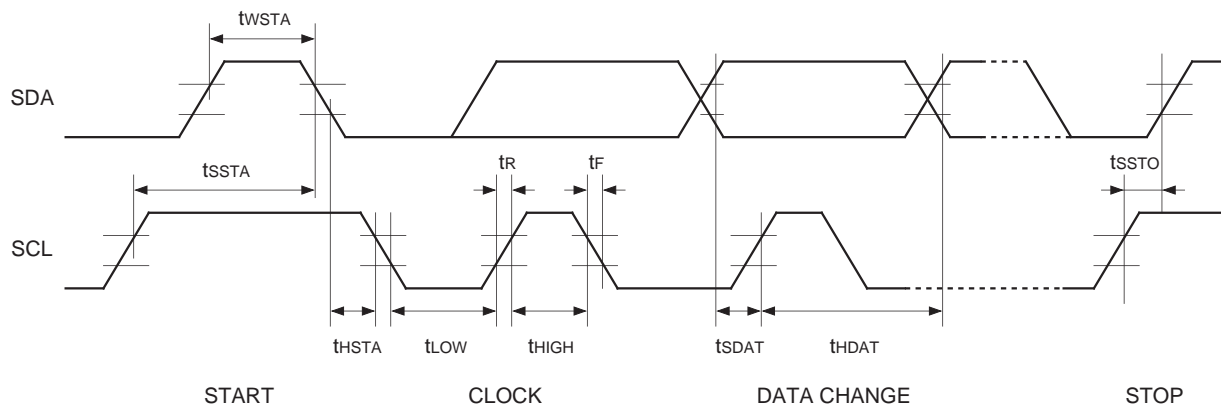

t_{SSTA} =Start setup time
 t_{WSTA} =Start waiting time
 t_{HSTA} =Start hold time
 t_{LOW} =LOW clock pulse width
 t_{HIGH} =HIGH clock pulse width

t_{SDAT} =Data setup time
 t_{HDAT} =Data hold time
 t_{SSSTO} =Stop setup time
 t_{R} =Rise time
 t_{F} =Fall time

Example of Representative Characteristics

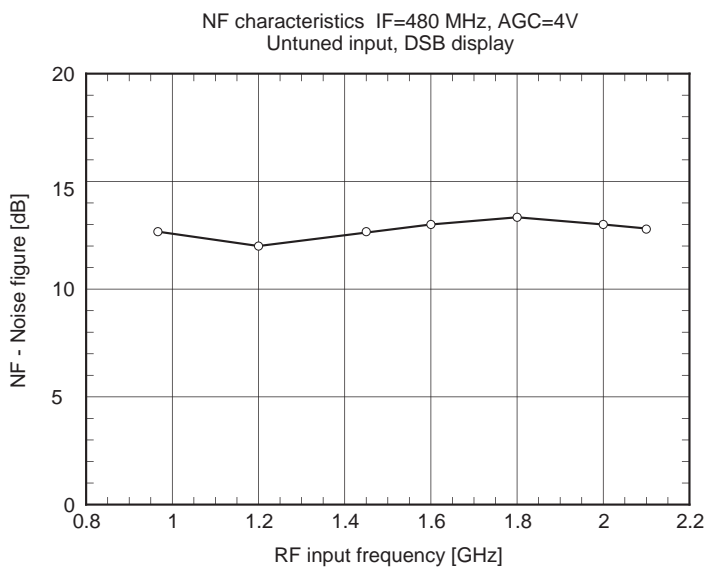
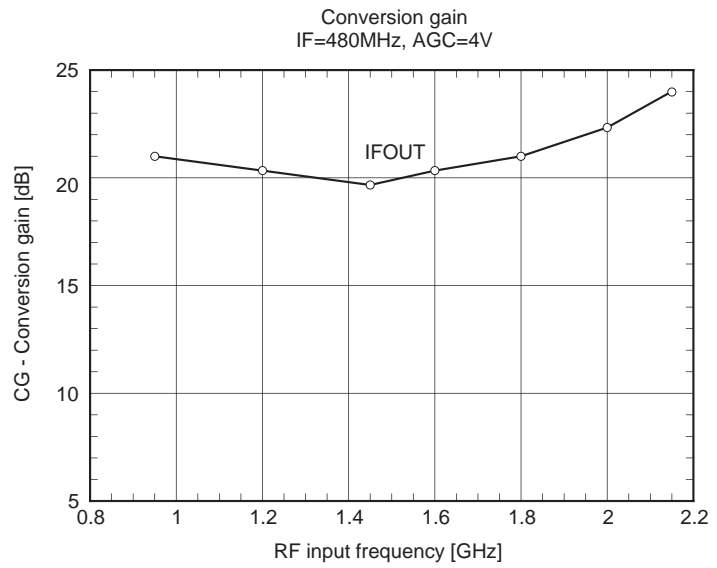
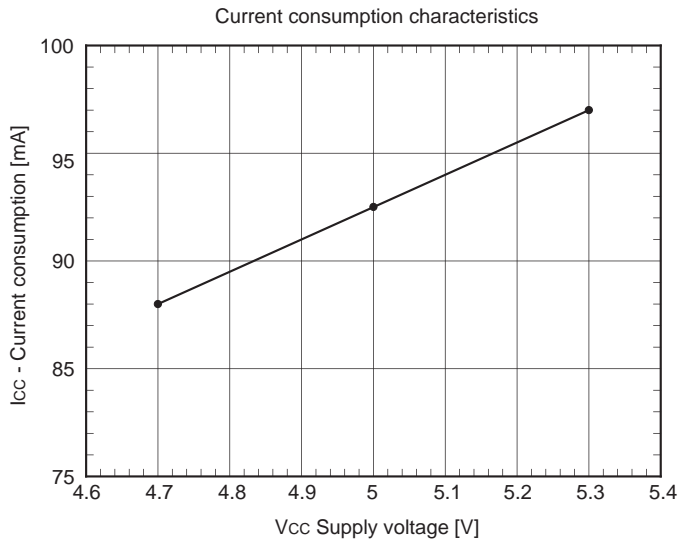

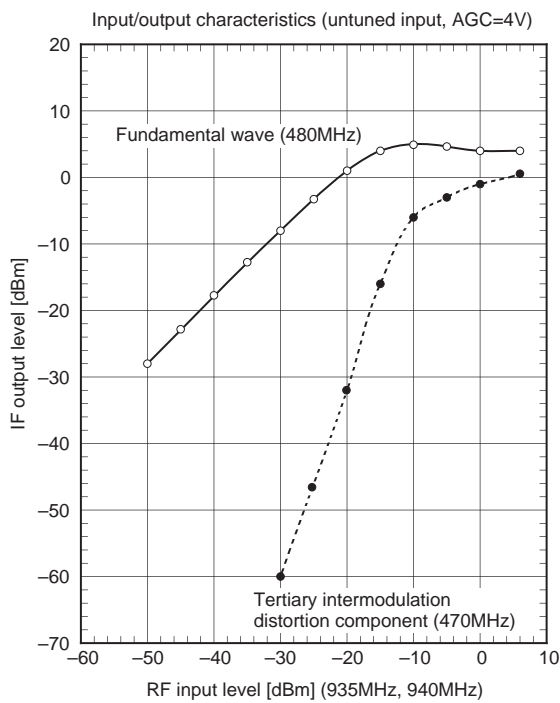
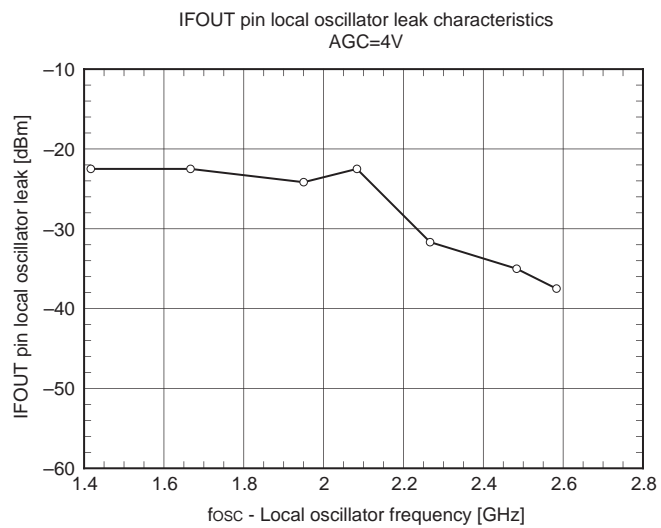
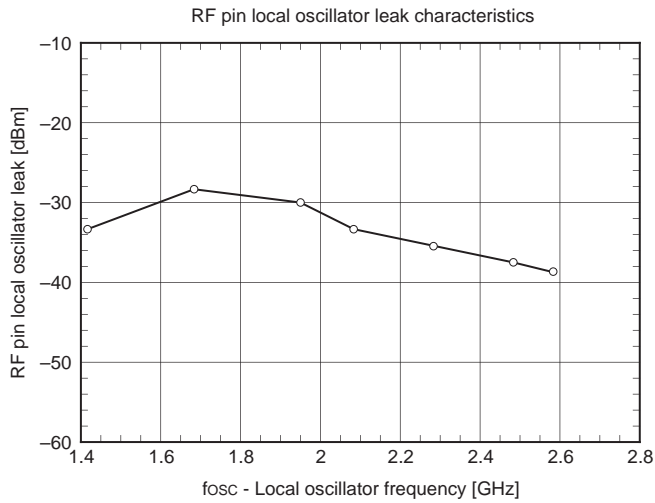

Input Impedance

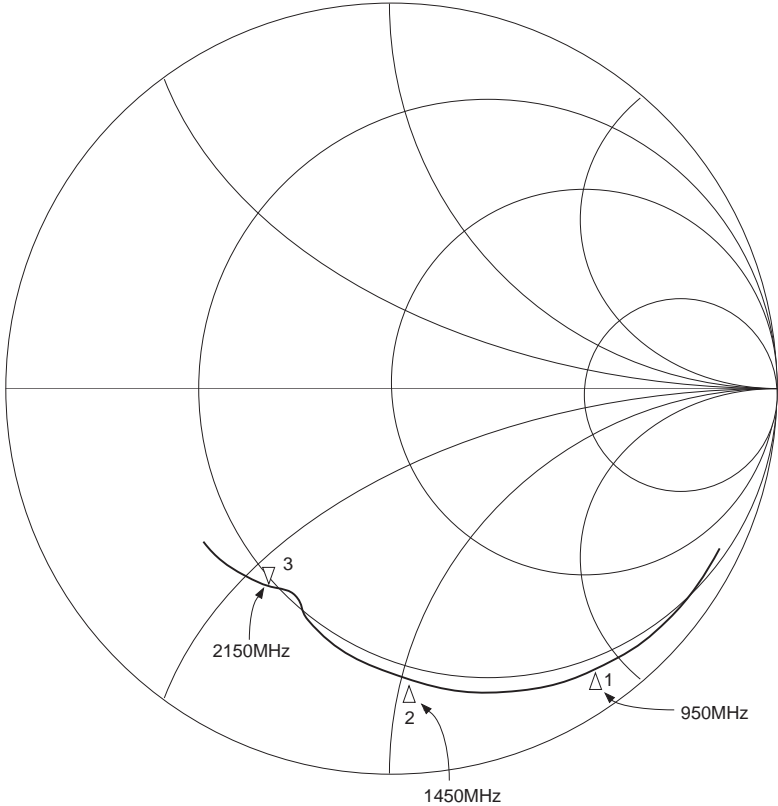

Output Impedance

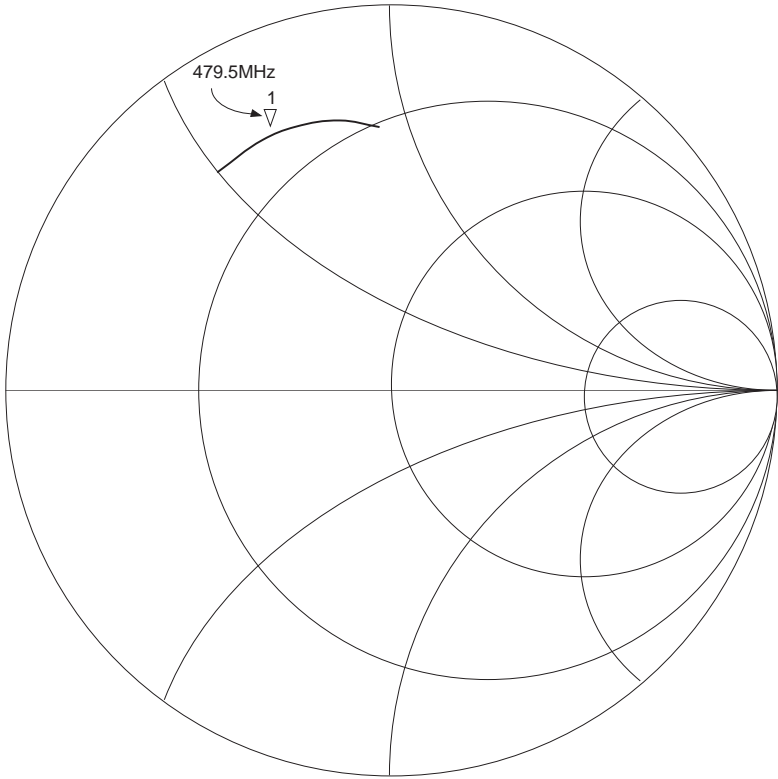

Package Outline Unit : mm

40PIN QFP (PLASTIC)

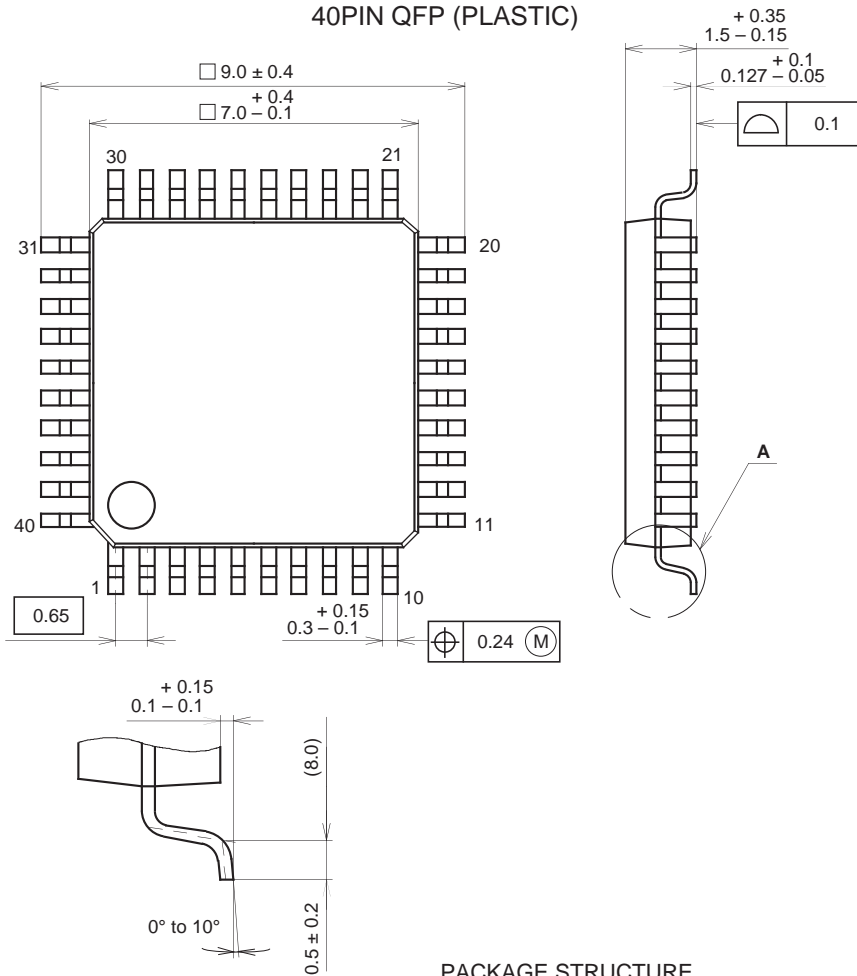

DETAIL A

PACKAGE STRUCTURE

| | |
|------------|---------------|
| SONY CODE | QFP-40P-L01 |
| EIAJ CODE | QFP040-P-0707 |
| JEDEC CODE | _____ |

| | |
|------------------|----------------------------|
| PACKAGE MATERIAL | EPOXY RESIN |
| LEAD TREATMENT | SOLDER / PALLADIUM PLATING |
| LEAD MATERIAL | 42/COPPER ALLOY |
| PACKAGE MASS | 0.2g |



LittleDiode supplies new, hard to find or obsolete electronic components and semiconductors all over the world.

With over two million different components listed you are sure to find the part you need.

Feel free to visit us today at our online store:

LittleDiode.com

Looking forward to providing you with the best possible service.