

L-band Down Converter for Satellite Tuner

Description

The CXA3068N is a monolithic IC to down-convert the L-band (930 to 2150 MHz) signal for the satellite broadcasting receiver. It has a double-balanced mixer, local oscillator circuit and IF amplifier on chip.

Features

- Balance-type Colpitts oscillator circuit provides a stable and wide range oscillation.
Oscillation frequency : 2.63 GHz
- Small leak of the local oscillation signal due to the double-balanced mixer.
- Oscillation frequency drift is small, caused by the change of impedance at the pre-stage of RF input.
- Local oscillator output circuit for PLL.
- Single 5 V power supply operation.
- Low current consumption. $I_{cc}=53$ mA (typ.)
- 16-pin SSOP package contributes to reduction in set size.

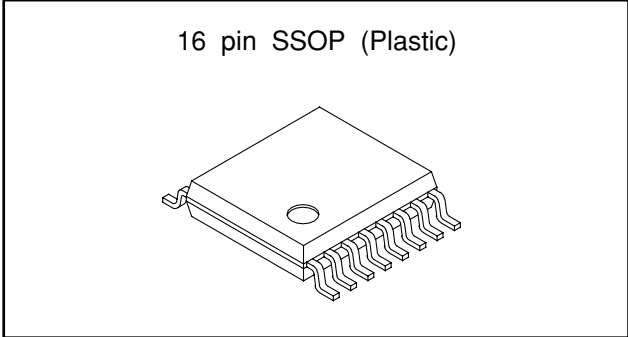

Absolute Maximum Ratings (Ta=25 °C)

• Supply voltage	V _{CC}	-0.3 to +5.5	V
• Storage temperature	T _{stg}	-55 to +150	°C
• Allowable power dissipation	P _D	625	mW
(When mounted on board)			

Operating Conditions

• Supply voltage	V _{CC}	4.75 to 5.3	V
• Ambient temperature	T _{opr}	-20 to 75	°C

Applications

- Satellite broadcasting tuners for BS, CS, DSS and DVB. (Frequency conversion to the second IF)

Structure

Bipolar silicon monolithic IC

Block Diagram and Pin Configuration

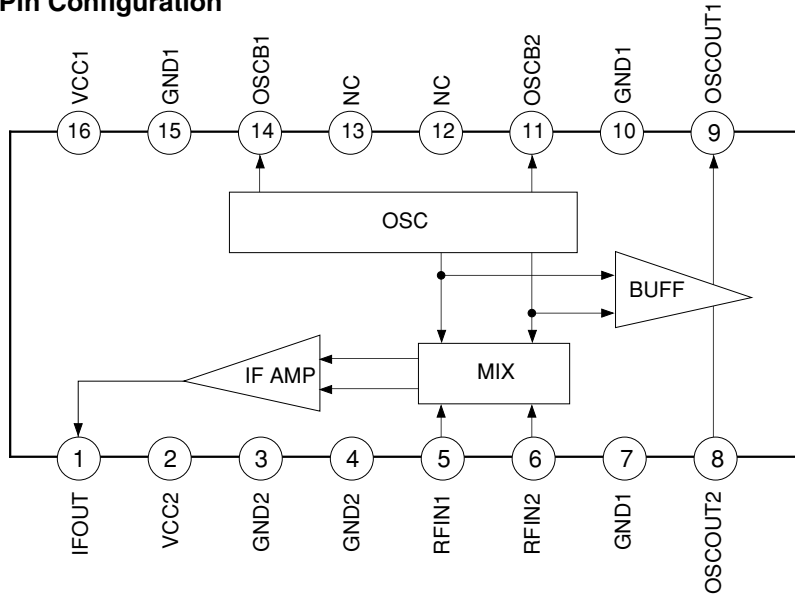

Sony reserves the right to change products and specifications without prior notice. This information does not convey any license by any implication or otherwise under any patents or other right. Application circuits shown, if any, are typical examples illustrating the operation of the devices. Sony cannot assume responsibility for any problems arising out of the use of these circuits.

Pin Description and Equivalent Circuit

Pin No.	Symbol	Typical pin voltage (V)	Equivalent circuit	Description
1	IF OUT	2.5		IF output.
2	VCC2	5.0		IF block power supply.
3	GND2	0		IF block GND.
4	GND2	0		IF block GND.
5	RF IN1	1.8		RF input. Normally, a decoupling capacitor is connected at Pin 5 to GND and Pin 6 is used for input.
6	RF IN2	1.8		
7	GND1	0		RF block GND.
8	OSC OUT2	3.5		Local oscillation output.
9	OSC OUT1	3.5		

Pin No.	Symbol	Typical pin voltage (V)	Equivalent circuit	Description
10	GND1	0		RF block GND.
11	OSC B2	2.4		Oscillator.
12	NC	—		
13	NC	—		
14	OSC B1	2.4		
15	GND1	0		RF block GND.
16	VCC1	5.0		RF block power supply.

Electrical Characteristics (Ta=25 °C, Vcc=5 V, refer to the Electrical Characteristics Measurement Circuit.)

Input frequency: 950 to 2150 MHz

No	Item	Symbol	Measurement conditions	Min.	Typ.	Max.	Unit
1	Current consumption	I _{cc}	No signal	31.0	53.0	75.0	mA
2	Conversion gain *1	CG1	f _{in} = 950 MHz, f _{iF} = 480 MHz	16	19	23	dB
		CG2	f _{in} = 1450 MHz, f _{iF} = 480 MHz	18	21	25	dB
		CG3	f _{in} = 2150 MHz, f _{iF} = 480 MHz	19	22	26	dB
3	Noise figure *1, 2	NF1	f _{in} = 950 MHz, f _{iF} = 480 MHz		16	19	dB
		NF2	f _{in} = 1450 MHz, f _{iF} = 480 MHz		14	16	dB
		NF3	f _{in} = 2150 MHz, f _{iF} = 480 MHz		14	16	dB
4	Local oscillation output	Posc1	f _{osc} = 1430 to 1830 MHz	-10	-6		dBm
		Posc2	f _{osc} = 1830 to 2230 MHz	-10	-6		dBm
		Posc3	f _{osc} = 2230 to 2630 MHz	-11	-7		dBm
5	IF maximum output	P _o (sat)	f _{iF} = 480 MHz	5.5	8.5	11.0	dBm
6	RF pin local oscillation leakage	RFLK1	f _{osc} = 1430 to 1830 MHz			-20	dBm
		RFLK2	f _{osc} = 1830 to 2230 MHz			-20	dBm
		RFLK3	f _{osc} = 2230 to 2630 MHz			-20	dBm
7	IF pin local oscillation leakage	IFLK1	f _{osc} = 1430 to 1830 MHz			-20	dBm
		IFLK2	f _{osc} = 1830 to 2230 MHz			-32	dBm
		IFLK3	f _{osc} = 2230 to 2630 MHz			-32	dBm
8	Third-order intermodulation distortion *1, 3	IM3	P _{in} = -25 dBm f _{in} = 950 MHz + 960 MHz f _{out} = 470 MHz + 480 MHz S/I of 460 MHz and 480 MHz		45.0		dB
9	Local oscillation phase noise	CN1	f _{osc} =1430 MHz, offset 10 kHz		74		dBc/Hz
		CN2	f _{osc} =1430 MHz, offset 100 kHz		95		dBc/Hz
10	IF output VSWR	IFVSWR	f = 480 MHz		1.2		
11	RF input impedance	r _π	f = 950 MHz		140		Ω
		C _π			5		pF

*1) Measured value for untuned inputs.

*2) Noise figure is uncorrected for image.

*3) Measure S/I of the desired intermediate frequency (480 MHz) and distortion component (460 MHz) with a spectrum analyzer, assuming input level of the reception frequency to be -25 dBm (when IC input pin is converted for 50 Ω).

Electrical Characteristics Measurement Circuit

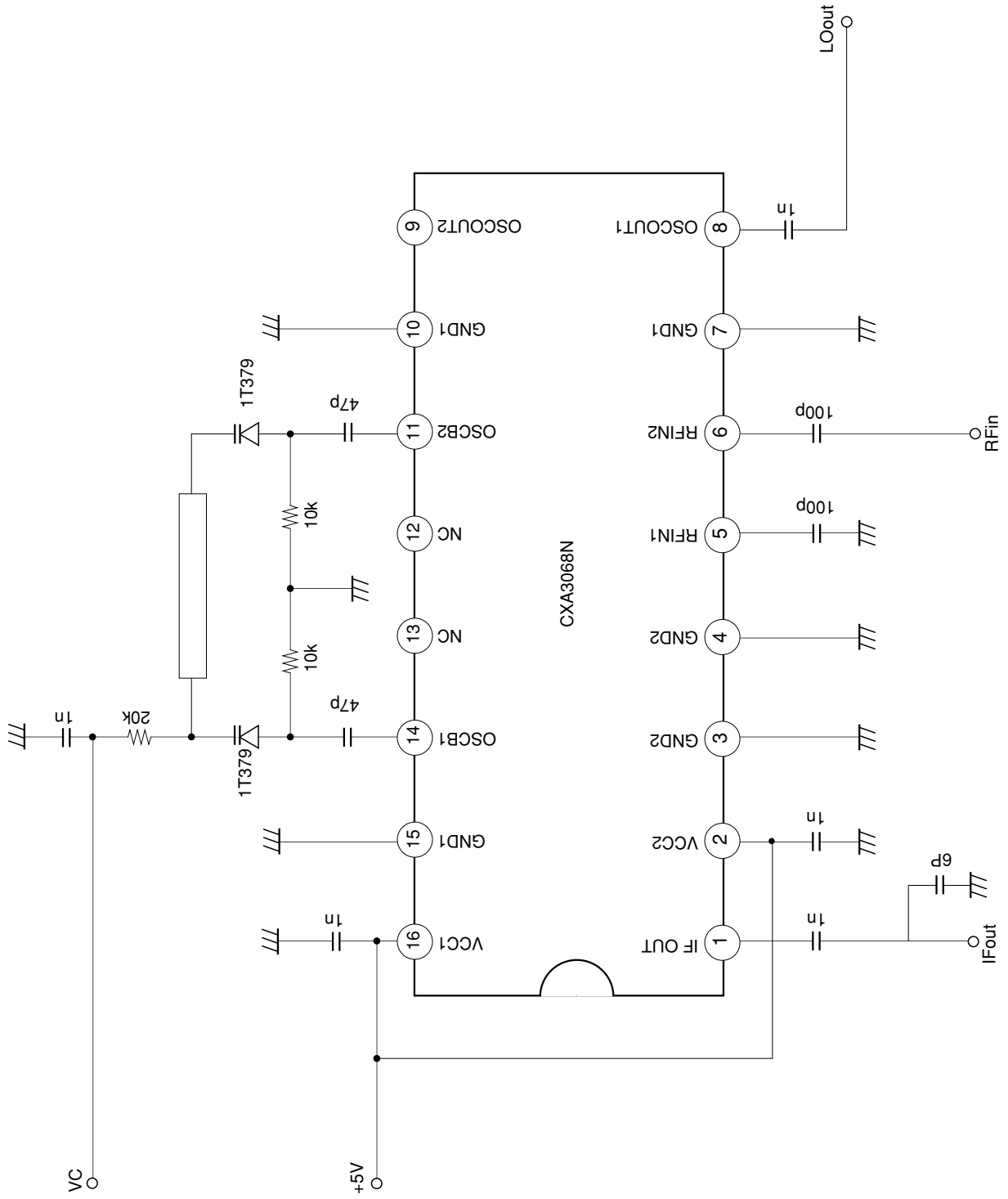

Description of Operation (Refer to the Electrical Characteristics Measurement Circuit.)

1) Oscillator circuit

The oscillator circuit is formed with two Colpitts oscillators, and oscillation is provided at the differential input via an LC resonance circuit including a varicap diode. This is oscillated only by attaching an LC resonance circuit externally because feedback capacitance, etc. are built in for oscillation.

2) Mixer circuit

This is a double-balance mixer having small leak of local oscillation signal. The RF signal is input to Pins 5 and 6. In normal use, the signal is input to one pin while the other pin is connected to GND via decoupling capacitor.

3) IF amplifier circuit

The mixer output signal is amplified by the IF amplifier and output to Pin 1. The IF output is emitter-follower output and output impedance is approximately 50 Ω (480 MHz).

4) PLL oscillation signal output circuit

The output circuit is built in to drive the PLL for tuning. This is emitter-follower output and output impedance is approximately 50 Ω .

Current consumption vs. Supply voltage

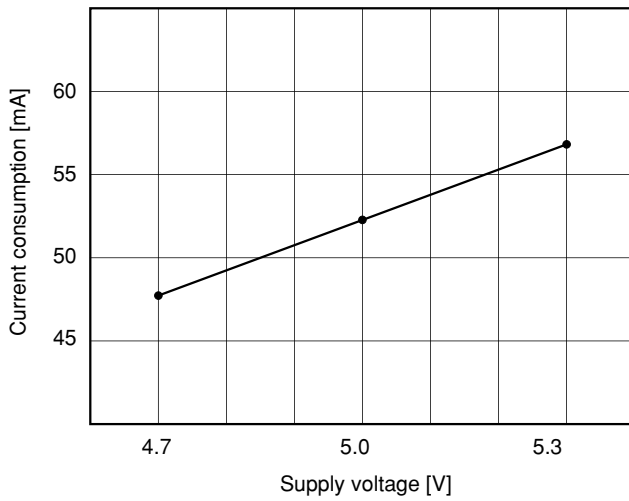

Conversion gain vs. Reception frequency (untuned input)

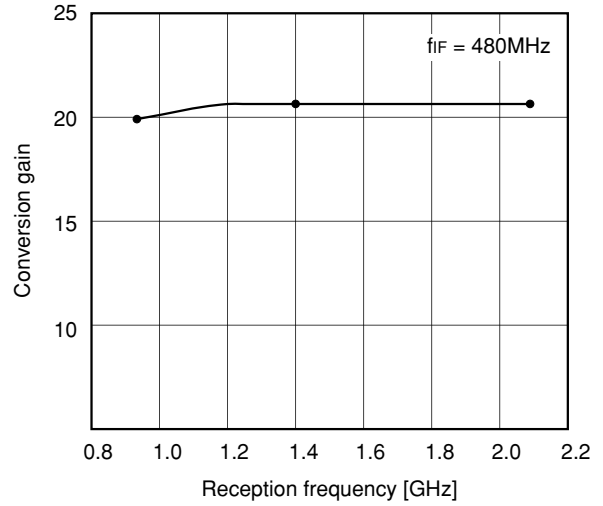

Noise figure vs. Reception frequency (untuned input, in DSB)

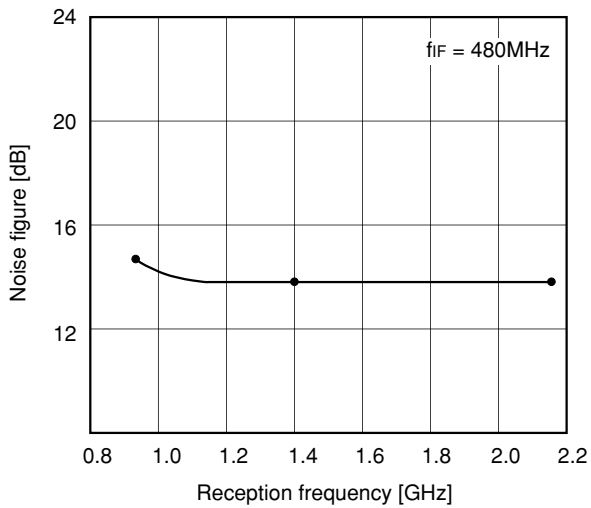

Local oscillation output level vs. Local oscillation frequency

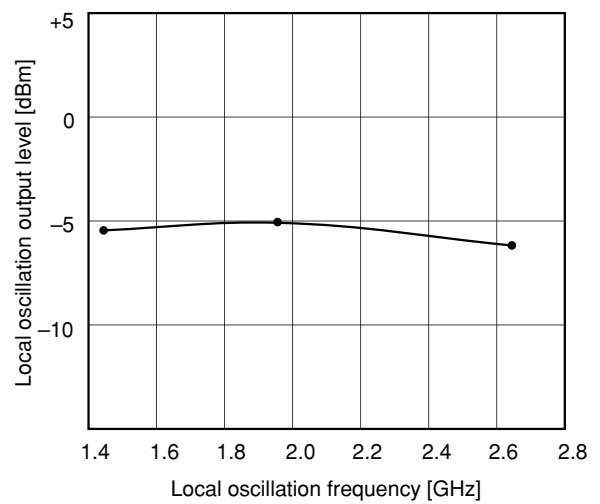

IF pin local oscillation leak vs. Local oscillation frequency

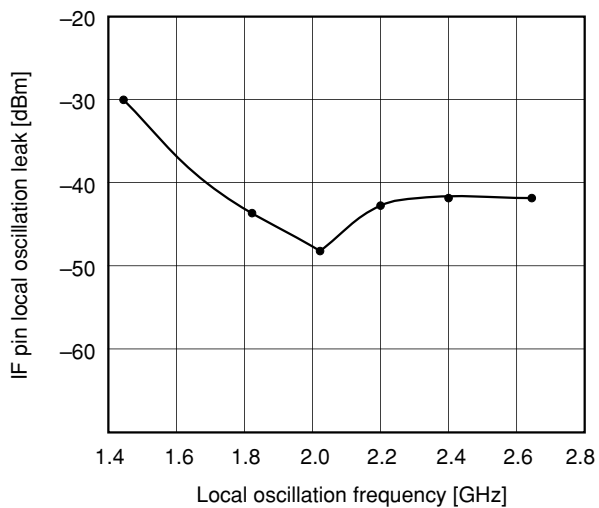

RF pin oscillation frequency leak vs. Local oscillation frequency

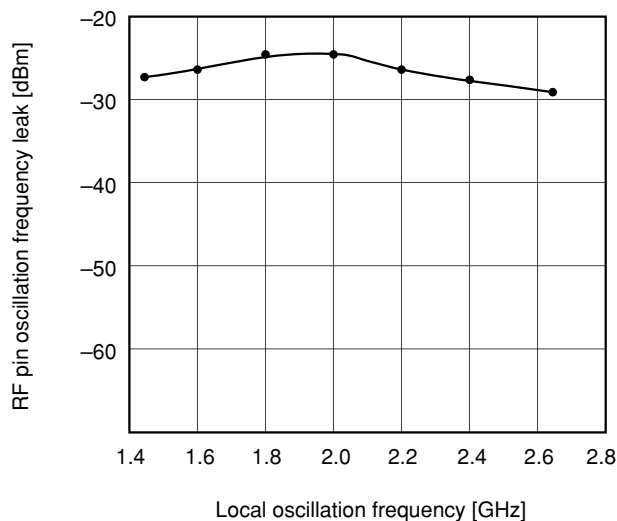

Input/output characteristics (untuned input)

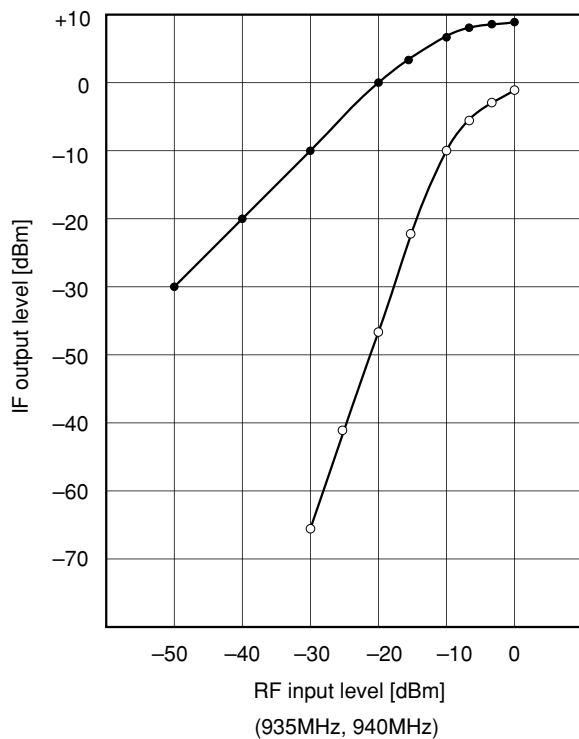

- = Fundamental-frequency (480MHz)
- = Third-harmonics (470MHz)

Input Impedance

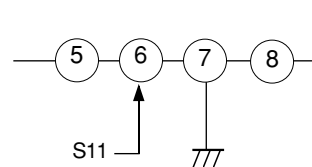
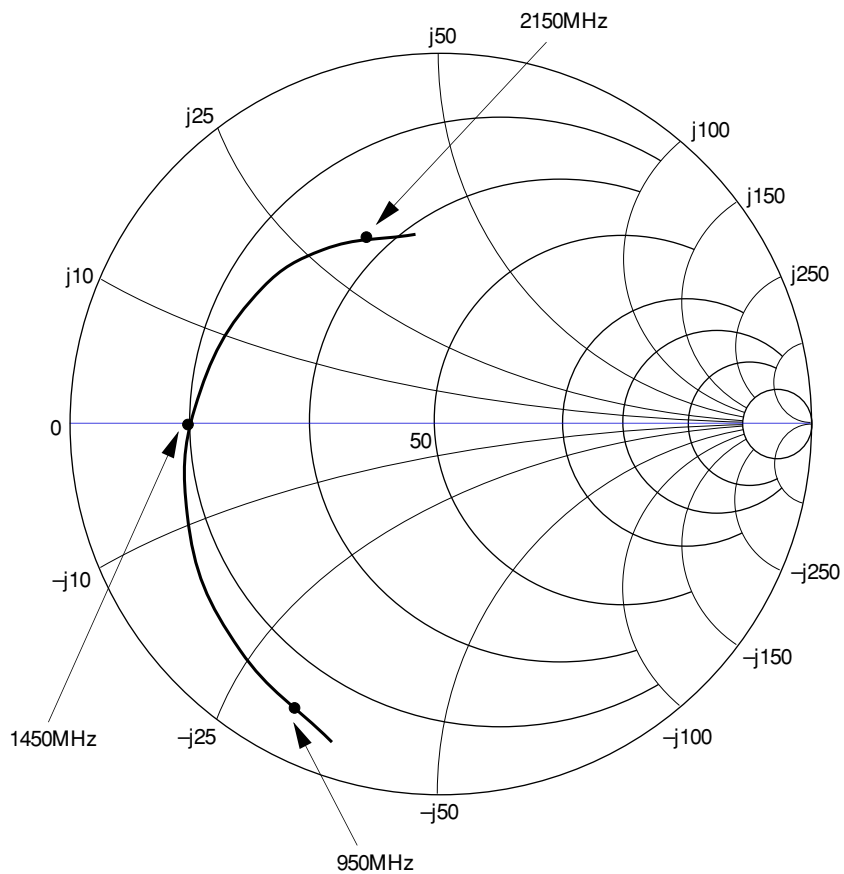

Output Impedance (IF)

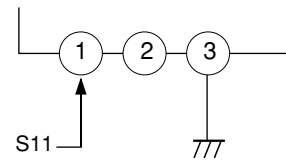
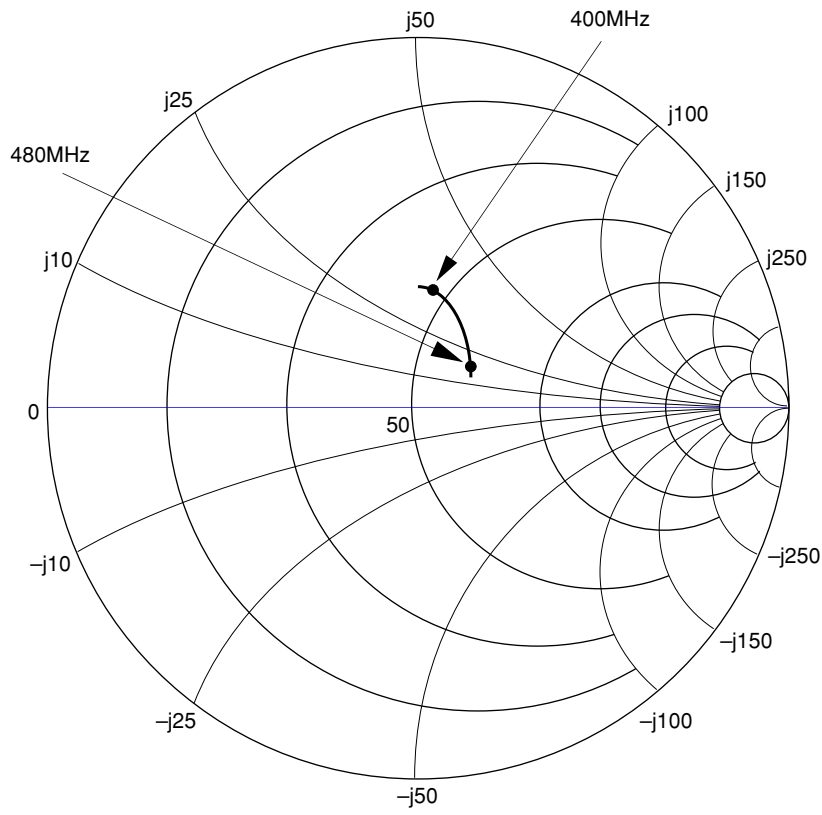

Output Impedance (local oscillation output)

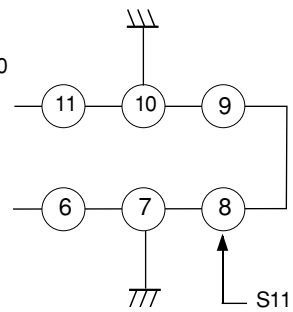
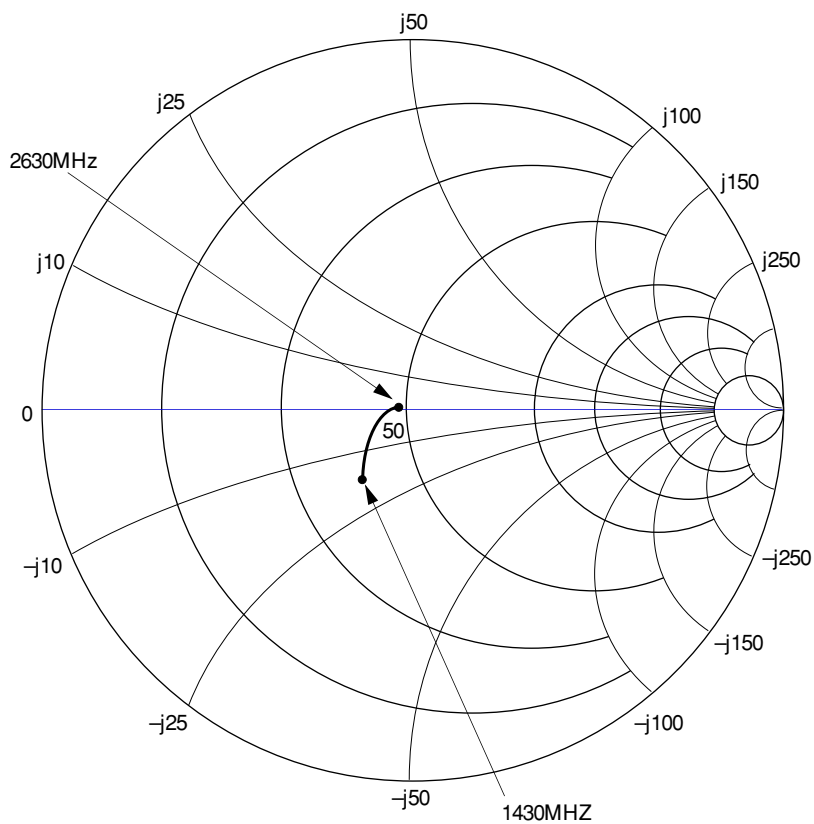

Package Outline Unit : mm

16PIN SSOP (PLASTIC)

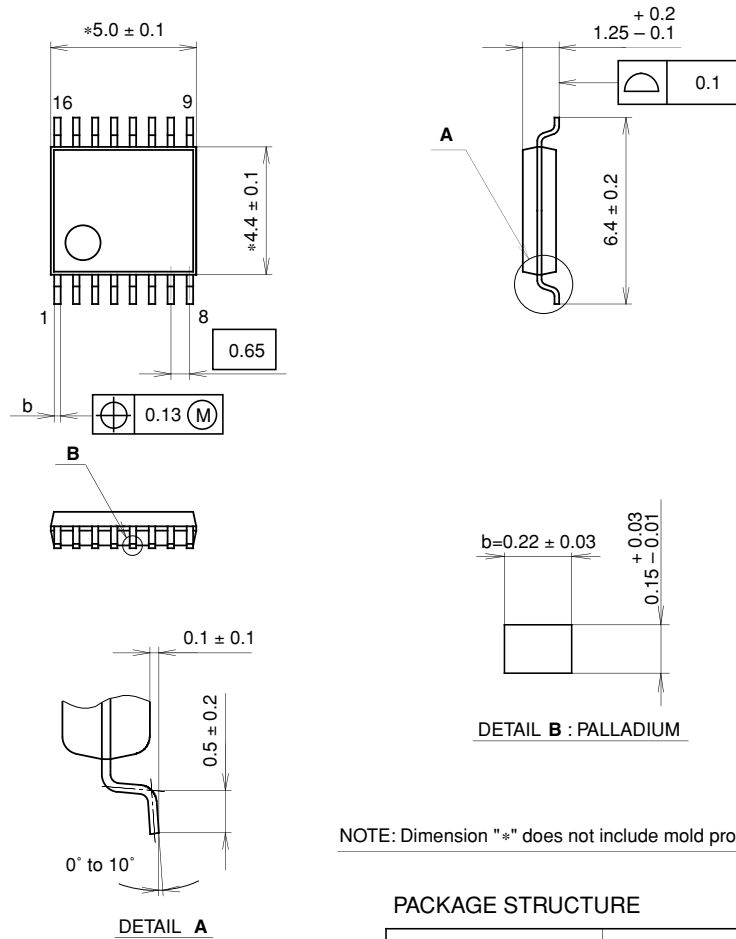

NOTE: Dimension "*" does not include mold protrusion.

PACKAGE STRUCTURE

PACKAGE MATERIAL	EPOXY RESIN
LEAD TREATMENT	PALLADIUM PLATING
LEAD MATERIAL	COPPER ALLOY
PACKAGE MASS	0.1g

SONY CODE	SSOP-16P-L01
EIAJ CODE	P-SSOP16-4.4x5.0-0.65
JEDEC CODE	



LittleDiode supplies new, hard to find or obsolete electronic components and semiconductors all over the world.

With over two million different components listed you are sure to find the part you need.

Feel free to visit us today at our online store:

LittleDiode.com

Looking forward to providing you with the best possible service.