

Wide Band FSK Receiver

Description

The CXA3067AM is an integrated circuit designed for CATV wide band FSK receiver. This monolithic IC is composed of local oscillator, double balanced mixer, limiter, FM detector, data shaper and PLL circuit in a single chip.

Features

- Built in PLL
- 3 bits 3 states frequency selection
- Applied for 4 reference frequency (7.15625/7.15909/14.3125/14.31818 MHz)
- Compatible with external reference clock and X'tal oscillator
- Balanced oscillator and double balanced mixer for low L.O. leakage
- Low power consumption
- SOP 30 pin package

Function

- Oscillator
- Mixer
- PLL
- Limiter
- FSK detector
- Data shaper

Applications

FSK receiver for CATV

Structure

Bipolar silicon monolithic IC

30 pin SOP (Plastic)

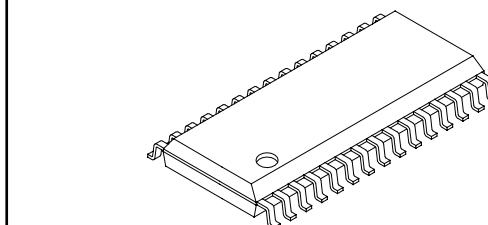

Absolute Maximum Ratings (Ta=25 °C)

- | | | | |
|-----------------------|------------------|--------------|----|
| • Supply voltage | V _{CC} | -0.3 to +5.5 | V |
| • Storage temperature | T _{stg} | -55 to +150 | °C |

Operating Conditions

- | | | | |
|-------------------------|------------------|-------------|----|
| • Supply voltage | V _{CC} | 4.75 to 5.3 | V |
| • Operating temperature | T _{opr} | -25 to +75 | °C |

Sony reserves the right to change products and specifications without prior notice. This information does not convey any license by any implication or otherwise under any patents or other right. Application circuits shown, if any, are typical examples illustrating the operation of the devices. Sony cannot assume responsibility for any problems arising out of the use of these circuits.

Pin configuration and Block diagram

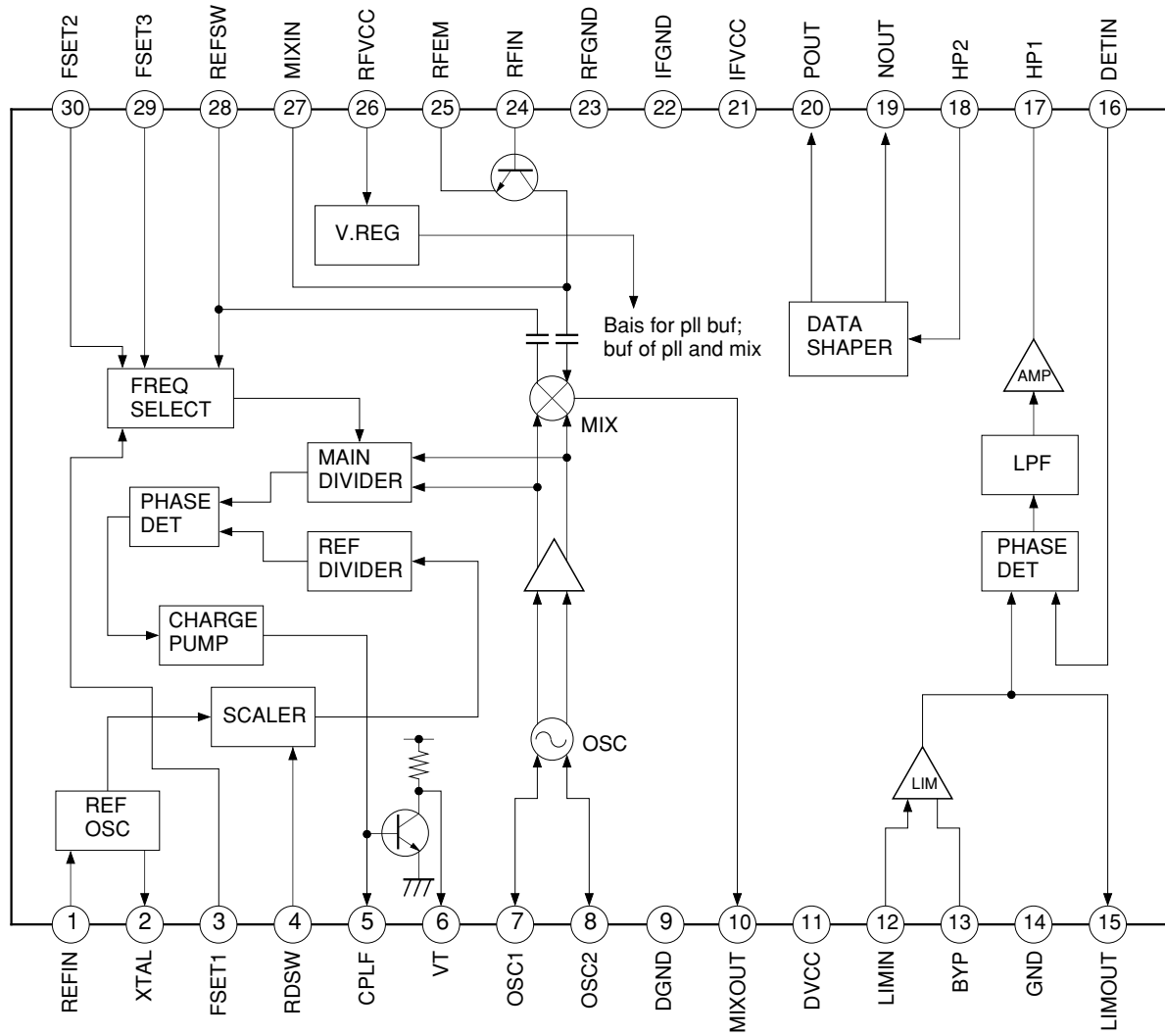

Pin Description and Equivalent Circuit

Pin No.	Symbol	Typical voltage (V)	Equivalent circuit	Description
1	REFIN	3.4		External clock input and X'tal connection for reference oscillator.
2	XTAL	4.0		X'tal connection for reference oscillator.
3	FSET1	2.5 (OPEN)		The pin for channel selection. The condition of pin 3 has 3 states. Connect to 5 V source for "Hi" selection and connect to GND for "Low" selection and leave open.
4	RDSW	3.0 (OPEN)		Reference frequency selection. Connect to GND when reference frequency is 14.3125 MHz or 14.31818 MHz and leave open when reference frequency is 7.15625 MHz or 7.15909 MHz.
5	CPLF	2.0		Charge pump output. Connect to loop filter.
6	VT	0.3 to V _{cc}		Connect to loop filter. OSC tuning voltage output.

Pin No.	Symbol	Typical voltage (V)	Equivalent circuit	Description
7	OSC1	4.0		Oscillator.
8	OSC2	4.0		
9	DGND	0		PLL circuit GND.
10	MIXOUT	4.0		Mixer output. Output impedance is 330 Ω.
11	DVCC	5		PLL circuit power supply.
12	LIMIN	2.4		Limiter input. Input impedance is 330 Ω.
13	BYP	2.4		
14	GND	0		GND.
15	LIMOUT	3.1		Limiter output.

Pin No.	Symbol	Typical voltage (V)	Equivalent circuit	Description
16	DETIN	5.0		Detector input. Connect to a discriminator.
17	HP1	2.1		A capacitor for DC decoupling and LPF are connected between pins 17 and 18.
18	HP2	2.3		
19	NOUT	4.1 (Hi) 0.22 (Low)		FSK data output.
20	POUT	4.1 (Hi) 0.22 (Low)		Pins 19 and 20 are each other reversal condition.
21	IFVCC	5.0		Power supply for limiter, detector, data shaper circuit.

Pin No.	Symbol	Typical voltage (V)	Equivalent circuit	Description
22	IFGND	0		GND for limiter, detector, data shaper circuit.
23	RFGND	0		GND for RFamp, Mixer, oscillator circuit.
24	RFIN	1.5		RFamp input.
25	RFEM	0.7		Gain adjustment. Normally, by-pass capacitor is connected at pin 25 to GND.
27	MIXIN	5.0		RFamp output and mixer input.
26	RFVCC	5.0		Power supply for RFamp, mixer, oscillator circuit.
28	REFSW	0.7 (OPEN)		Reference frequency selection. Decoupling capacitor is connected at pin 28 to GND when reference frequency is 7.15909 MHz or 14.31818 MHz and pin 28 is connected to GND directly when reference frequency is 7.15625 MHz or 14.3125 MHz.
29	FSET3	2.5 (OPEN)		The pin of channel selection. The condition of pin 29 has 3 states. Connect to 5 V source for "Hi" selection and connect to GND for "Low" selection and leave open.
30	FSET2	2.5 (OPEN)		The pin of channel selection. The condition of pin 30 has 3 states. Connect to 5 V source for "Hi" selection and connect to GND for "Low" selection and leave open.

Electrical Characteristics

See Electrical Characteristics Test Circuit (V_{CC}=5.0 V, T_a=+25 °C)

Item	Symbol	Pin No.	Circuit No.	Conditions	Min.	Typ.	Max.	Unit
RFVCC Current consumption	RFI _{CC}	26, 27	1	RFV _{CC} V1=5 V	17	28	39	mA
IFVCC Current consumption	IFI _{CC}	21	1	IFV _{CC} V2=5 V	4	9	14	mA
DVCC Current consumption	DI _{CC}	11	1	DV _{CC} V4=1 V V3=5 V	3.5	7	10	mA
Input sensitivity	Vi1		2	f _{MOD} =10 kHz, f _{DEV} =±75 k, ±50 kHz Jitter is 1 % for f _{MOD} 50 Ω Termination RF=53.35 M to 302 MHz frequency offset=±50 kHz	-32			dBmV
Input level	Vil		2	f _{MOD} =10 kHz, f _{DEV} =±75 k, ±50 kHz Jitter is 1 % for f _{MOD} 50 Ω Termination RF=53.35 M to 302 MHz frequency offset=±50 kHz			+20	dBmV
Duty cycle *1	TD			f _{MOD} =10 kHz f _{DEV} =±75 k, ±50 kHz Frequency offset=±50 kHz		0	6	%
DATA SHAPER input level	V18	18	2	f _{MOD} =10 kHz f _{DEV} =±75 k, ±50 kHz Frequency offset=±50 kHz	130	260	1000	mVpp
Local OSC leakage from RF input 1	LOleak1	24	2	Measurement on RFIN pin SW1 : ON RF=53.35 M to 169.5 MHz			-10	dBmV
Local OSC leakage from RF input 2	LOleak2	24	2	Measurement on RFIN pin SW1 : ON RF=221.95 M to 302 MHz			-5	dBmv
RFamp bias current	I _{rf}	27	1	RFV _{CC} V1=5 V	4.5	7	10	mA
RFamp voltage gain	G _{rf1}	24→27	3	RF=108.5 M	28	34	37	dB
RFamp input resistance	r _π (rf)	24		I=7.5 mA, RF=100 MHz Load Resistance=0 Ω		1.46		kΩ
RFamp input capacitance	C _π (rf)	24		I=7.5 mA, RF=100 MHz Load Resistance=0 Ω		3.4		pF
Mixer input resistance	r _π (mix)	27		RF=100 MHz		2.3		kΩ
Mixer input capacitance	C _π (mix)	27		RF=100 MHz		3.4		pF
Mixer voltage gain	G _{mix}	27→10	4	RF=108.5 MHz→ IF=10.7 MHz	9	13	17	dB
RFamp+Mixer noise figure *2	NF rfmix	24→10	5	RF=108.5 MHz→ IF=10.7 MHz		6		dB

Note) 0 dBmV=1 mV, 0 dBμV=1 μV
 0 dBmV=60 dBμV
 0 dBm=47 dBmV

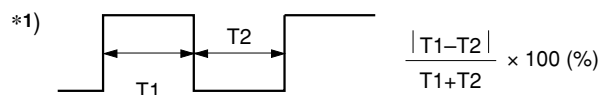

*2) Noise figure is uncorrected for image.

Item	Symbol	Pin No.	Circuit No.	Conditions	Min.	Typ.	Max.	Unit
Mixer output resistance	r_L (mix)	10		IF=10.7 MHz	222	332	442	Ω
Limiter input resistance	r_π (lim)	12		IF=10.7 MHz	222	332	442	Ω
Limiter voltage gain	Glim	15	6	IF=10.7 MHz		70		dB
FSK Data output voltage "H"	OUTH	19, 20	2	Load Capacitance=2 pF Load Resistance=10 k Ω , fMOD=10 kHz, fDEV=±75 kHz, ±50 kHz	3.8	4.1		V
FSK Data output voltage "L"	OUTL	19, 20	2	Load Capacitance=2 pF Load Resistance=10 k Ω , fMOD=10 kHz, fDEV=±75 kHz, ±50 kHz		0.22	0.6	V
FSK Data output rise time	Tr	19, 20	2	Load Capacitance=2 pF Load Resistance=10 k Ω , fMOD=10 kHz, fDEV=±75 kHz, ±50 kHz		12	30	nsec
FSK Data output fall time	Tf	19, 20	2	Load Capacitance=2 pF Load Resistance=10 k Ω , fMOD=10 kHz, fDEV=±75 kHz, ±50 kHz		12	30	nsec
Oscillation frequency	OSC	7, 8			40		315	MHz
VT output voltage range	VT	6			0.3	2.5	Vcc	V
Charge pump current	Icp	5	7	Source current → SW2 : OFF SW3 : OFF Sink current → SW2 : ON SW3 : ON	±25	±50	±75	μ A
REFCLOCK input level 1	CLK 1	1		Sin wave input	0.3	0.4	3.0	Vp-p
REFCLOCK input level 2	CLK 2	1		Square wave input	0.3	0.4	3.0	Vp-p
REFOSC loop gain	Gref	1, 2	3	Vin2=14 MHz		30		dB
FSET1/2/3 "Hi" level input voltage	FSETVH	3, 29, 30	1		3.8		Vcc	V
FSET1/2/3 "Low" level input voltage	FSETVL	3, 29, 30	1		0		0.4	V
FSET1/2/3 "Hi" level input current	FSETIH	3, 29, 30	1	FSET "Hi"=V5=5 V	100	250	380	μ A
FSET1/2/3 "Low" level input current	FSETIL	3, 29, 30	1	FSET "Low"=V5=0 V	-380	-250	-100	μ A
RDSW "Low" level input voltage	RDVL	4	1		0		0.4	V
RDSW "Low" level input current	RDIL	4	1	RDSW "L"=V6=0 V	-122	-83	-43	μ A
REFSW "Low" level input voltage	REFVL	28	1		0		0.4	V

Electrical Characteristics Test Circuit

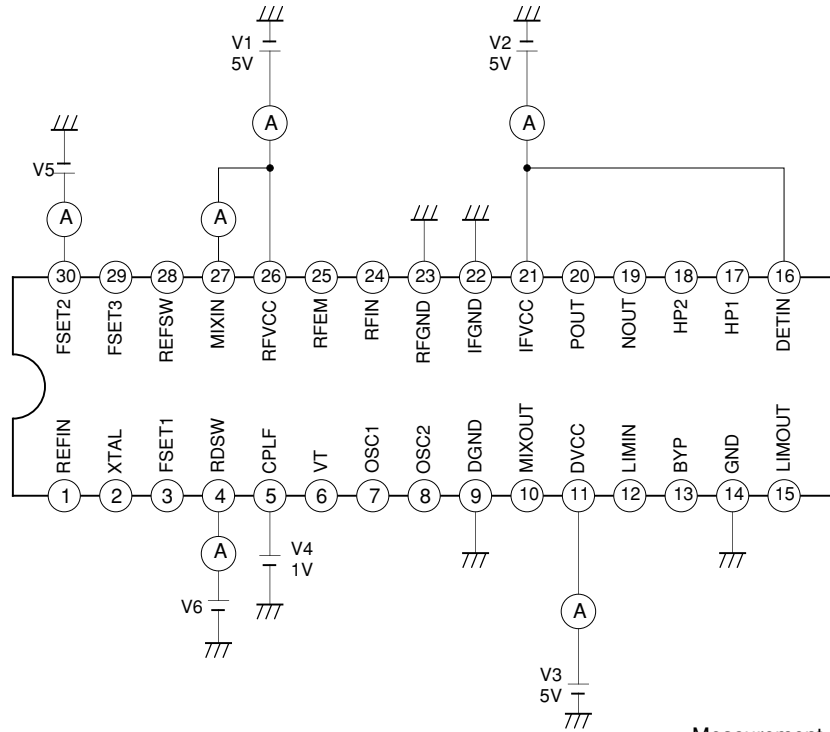

Measurement : Current consumption

Measurement circuit 1

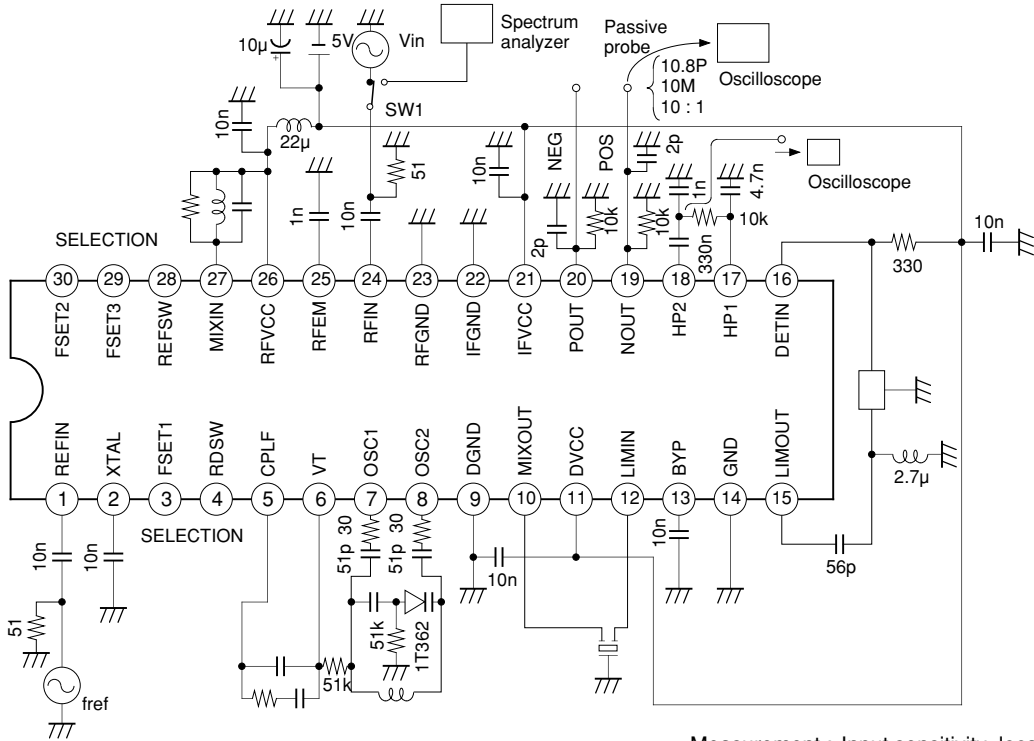

Measurement : Input sensitivity, local osc leakage,
DATA SHAPER input level
FSK DATA output voltage,
rise time, fall time

Measurement circuit 2

	Wire diameter	Coil diameter	Number of windings
L2	0.5	3.8 φ	6.5 T

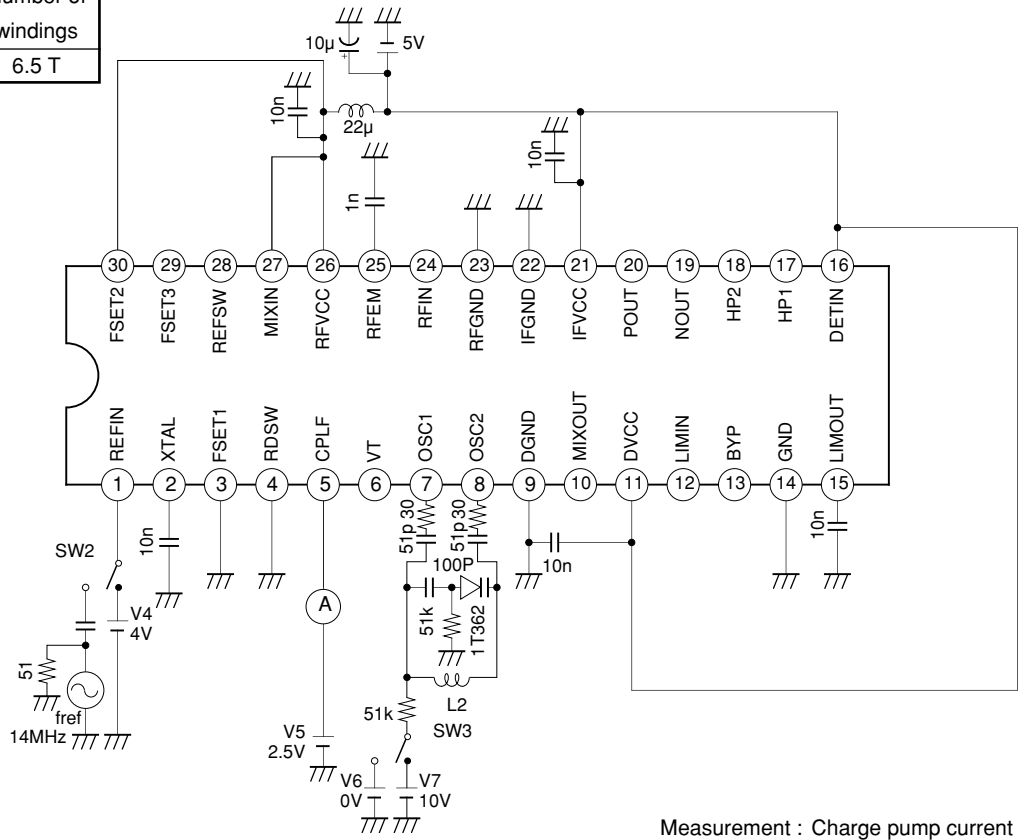

Measurement : Charge pump current

Measurement circuit 7

Function Explanation

The CXA3067AM is an integrated circuit designed for CATV wide band FSK receiver. This monolithic IC is composed of local oscillator, double balanced mixer, limiter, FM detector, data shaper and PLL circuit in a single chip.

The function of each other section is described below.

1. RFamp circuit

This circuit amplifies RF signal, and RF signal is input to pin 24 (RFIN).

Since pin 27 is an open collector, connect power supply through a coil which composes tune circuit or a choke coil or a resistor.

RF signal is selected a desired frequency by this tune circuit.

The desired frequency is input to mixer circuit through coupling capacitor.

2. Mixer circuit

This is a double-balanced mixer having small leakage of local signal.

The RF signal is converted to IF signal by the signal supplied from oscillator.

The output impedance is approximately 330 Ω .

Normally, connect a ceramic filter to 10 pin (MIXOUT).

3. Local oscillator circuit

The balanced oscillator circuit with pins 7 and 8 (OSC1, OSC2).

Connect an LC resonance circuit comprising a varicap diode to pins 7 and 8.

4. PLL circuit

The PLL circuit fixes the local oscillator frequency to desired frequency.

It consists of the main divider, reference divider, phase comparator, charge pump, reference oscillator.

As stated in the accompanying document, desired frequency (channel) can be selected through the combination of the conditions of pins 1, 29 and 30 (FSET 1; 2; 3).

As stated in the accompanying document, reference frequency can be selected through the combination the conditions of pin 3 (RDSW) and pin 28 (REFSW).

5. Limiter circuit

This circuit amplifies the mixer IF output through ceramic filter.

For quadrature FM detection, this circuit amplifies IF signal by necessary level.

The input impedance is approximately 330 Ω .

6. Detector circuit

For quadrature FM detection, the phase of limiter output (pin 15) is shifted 90° by discriminator as the output is input to pin 16.

7. Data shaper

This circuit output performs the waveform shaping of the demodulated FSK signal and outputs the resulting signal as a rectangular wave.

Description of PLL Block

1. The followings “channel No.” can be selected through the combination of the conditions of pins 1, 29 and 30 (FSET 1; 2; 3).

FSET conditions have 3 states (OPEN, Hi, Low).

Channel Selection

Channel No.	Local OSC frequency [MHz]	Receiving frequency [MHz]	FSET 1	FSET 2	FSET 3
1	42.65	53.35	OPEN	OPEN	OPEN
2	83.70	73.00	L	OPEN	OPEN
3	98.20	87.50	H	OPEN	OPEN
4	100.00	89.30	OPEN	L	OPEN
5	108.20	97.50	L	L	OPEN
6	117.20	106.50	H	L	OPEN
7	117.80	128.50	OPEN	H	OPEN
8	119.20	108.50	L	H	OPEN
9	133.40	122.70	H	H	OPEN
10	139.20	128.50	OPEN	OPEN	L
11	168.70	158.00	L	OPEN	L
12	180.20	169.50	H	OPEN	L
13	211.25	221.95	OPEN	L	L
14	219.10	229.80	L	L	L
15	312.70	302.00	H	L	L

Note) OPEN : No connect

L : Connect to GND

H : Connect to Vcc

2. The followings Reference frequency can be selected through the combination the conditions of pin 3 (RDSW) and pin 28 (REFSW).

When the pin 28 is connected to GND directly, the pin 28 is state of DCGND.

When the pin 28 is connected to GND through decoupling capacitor, the pin 28 is state of ACGND.

Reference Frequency selection

f (ref)	RDSW	REFSW
7.15625 MHz	OPEN	DCGND *1
7.15909 MHz	OPEN	ACGND *2
14.3125 MHz	GND	DCGND *1
14.31818 MHz	GND	ACGND *2

Note *1) Connect to GND directly.

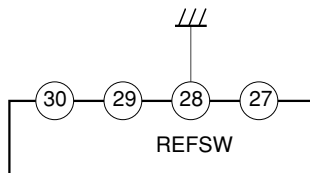

Note *2) Connect to GND through decoupling capacitor

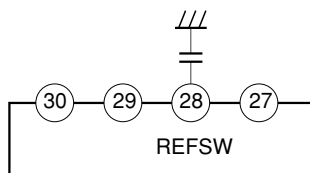

3. The comparison frequency is 25.021853 kHz at reference frequency 7.15625 MHz/14.3125 MHz, and 25.031783 kHz at reference frequency 7.15909 MHz/14.31818 MHz.

The frequency division ratio of the reference divider is 286.

The frequency division ratio of the scaler is 1 or 2;

When the reference frequency is 7.15625 MHz/7.15909 MHz, the frequency division ratio of the scaler is 1.

When the reference frequency is 14.3125 MHz/14.31818 MHz, the frequency division ratio of the scaler is 2.

Reference frequency=7.15625 MHz

The comparison frequency=7.15625/286=25.021853 kHz

Ch	fOSC [MHz]	Divider	8192	4096	2048	1024	512	256	128	64	32	16	8	4	2	1
1	42.65	1705	0	0	0	1	1	0	1	0	1	0	1	0	0	1
2	83.7	3345	0	0	1	1	0	1	0	0	0	1	0	0	0	1
3	98.2	3925	0	0	1	1	1	1	0	1	0	1	0	1	0	1
4	100	3997	0	0	1	1	1	1	1	0	0	1	1	1	0	1
5	108.2	4324	0	1	0	0	0	0	1	1	1	0	0	1	0	0
6	117.2	4684	0	1	0	0	1	0	0	1	0	0	1	1	0	0
7	117.8	4708	0	1	0	0	1	0	0	1	1	0	0	1	0	0
8	119.2	4764	0	1	0	0	1	0	1	0	0	1	1	1	0	0
9	133.4	5331	0	1	0	1	0	0	1	1	0	1	0	0	1	1
10	139.2	5563	0	1	0	1	0	1	1	0	1	1	1	0	1	1
11	168.7	6742	0	1	1	0	1	0	0	1	0	1	0	1	1	0
12	180.2	7202	0	1	1	1	0	0	0	0	1	0	0	0	1	0
13	211.25	8443	1	0	0	0	0	0	1	1	1	1	1	0	1	1
14	219.1	8756	1	0	0	0	1	0	0	0	1	1	0	1	0	0
15	312.7	12497	1	1	0	0	0	0	1	1	0	1	0	0	0	1

Reference frequency=7.15909 MHz

The comparison frequency=7.15909/286=25.031783 kHz

Ch	fOSC [MHz]	Divider	8192	4096	2048	1024	512	256	128	64	32	16	8	4	2	1
1	42.65	1704	0	0	0	1	1	0	1	0	1	0	1	0	0	0
2	83.7	3344	0	0	1	1	0	1	0	0	0	1	0	0	0	0
3	98.2	3923	0	0	1	1	1	1	0	1	0	1	0	0	1	1
4	100	3995	0	0	1	1	1	1	1	0	0	1	1	0	1	1
5	108.2	4323	0	1	0	0	0	0	1	1	1	0	0	0	1	1
6	117.2	4682	0	1	0	0	1	0	0	1	0	0	1	0	1	0
7	117.8	4706	0	1	0	0	1	0	0	1	1	0	0	0	1	0
8	119.2	4762	0	1	0	0	1	0	1	0	0	1	1	0	1	0
9	133.4	5329	0	1	0	1	0	0	1	1	0	1	0	0	0	1
10	139.2	5561	0	1	0	1	0	1	1	0	1	1	1	0	0	1
11	168.7	6739	0	1	1	0	1	0	0	1	0	1	0	0	1	1
12	180.2	7199	0	1	1	1	0	0	0	0	0	1	1	1	1	1
13	211.25	8439	1	0	0	0	0	0	1	1	1	1	0	1	1	1
14	219.1	8753	1	0	0	0	1	0	0	0	1	1	0	0	0	1
15	312.7	12492	1	1	0	0	0	0	1	1	0	0	1	1	0	0

Notes on Application

Take care of the followings because the CXA3067AM has limiter voltage gain of approximately 67 dB and uses high frequency.

- 1) Separate the input pattern from the output pattern as far as possible and makes wiring short.
- 2) Ground the decoupling capacitor as close to pin 13 as possible.

Take care of the followings in order to reduce the jitter.

- 1) Insert the capacitor as close to pin 17 and 18 as possible.
- 2) Ground the by-pass capacitor as close to IFV_{CC} to supply pin 16 as possible.

Take care of the following, for the purpose of the isolation of local oscillator resonance circuit and X'tal (RFF CLOCK).

- 1) Separate the patterns connected pin 1 and pin 2 from the local oscillator resonance circuit.

Take care of the following, in order to reduce the phase noise.

- 1) Connect the loop filter as close to pins 5 and 6 as possible.

Take care of the following, in order to prevent the parasitic oscillation.

- 1) Connect the local oscillator resonance circuit as close to pins 7 and 8 as possible.
And compact the local oscillator resonance circuit.

The tuning voltage at the local oscillator resonance circuit.

The output voltage at pin 6 is 0.3 V to V_{CC}.

When the oscillation frequency is the desired frequency, please the output voltage at pin 6 should be been 2.5 V.

Please decide the component value of loop filter by each system.

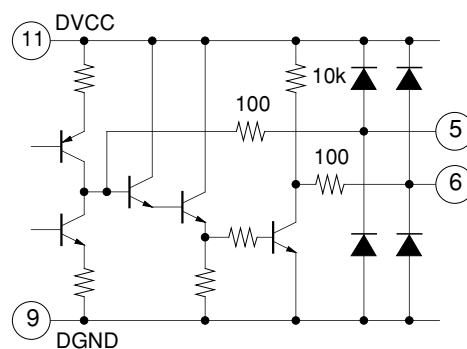

Application

fref	RDSW	REFSW
7.15625 MHz	OPEN	DCGND
7.15909 MHz	OPEN	ACGND
14.3125 MHz	GND	DCGND
14.31818 MHz	GND	ACGND

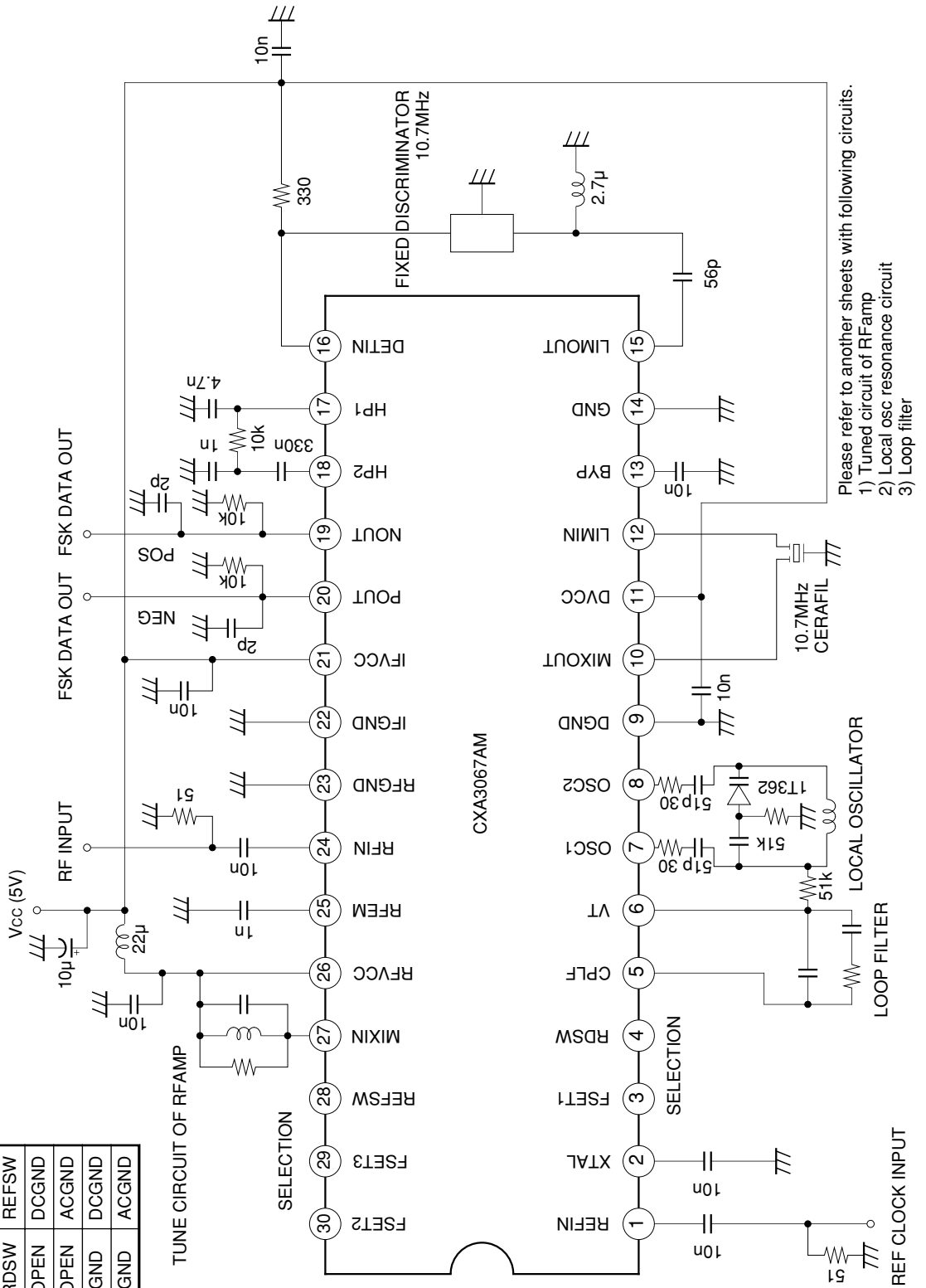

Please refer to another sheets with following circuits.
 1) Tuned circuit of RFamp
 2) Local osc resonance circuit
 3) Loop filter

Application circuits shown are typical examples illustrating the operation of the devices. Sony cannot assume responsibility for any problems arising out of the use of these circuits or for any infringement of third party patent and other right due to same.

The component value of the tune circuit, local oscillator resonance circuit and loop filter.

Channel No.	Tune circuit of RFamp	Local oscillator resonance circuit	Loop filter
1			
2			
3			
4			
5			
6			
7			
8			

Channel No.	Tune circuit of RFamp	Local oscillator resonance circuit	Loop filter
9			
10			
11			
12			
13			
14			
15			

Supply voltage vs. Current consumption

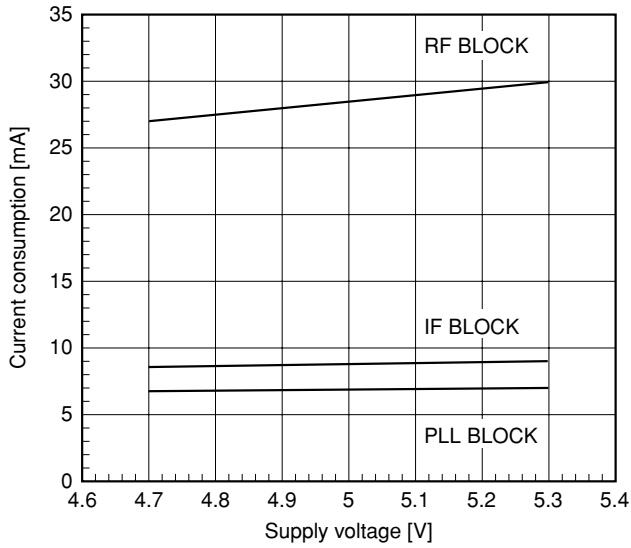

Frequency response RF amp voltage gain

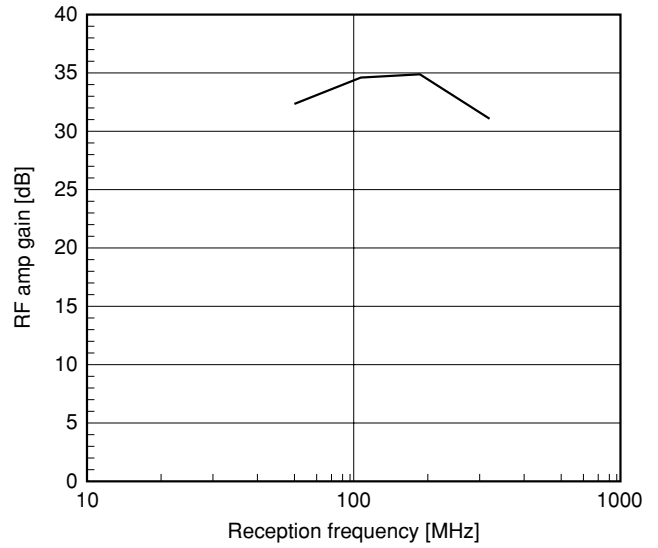

Frequency response limiter voltage gain

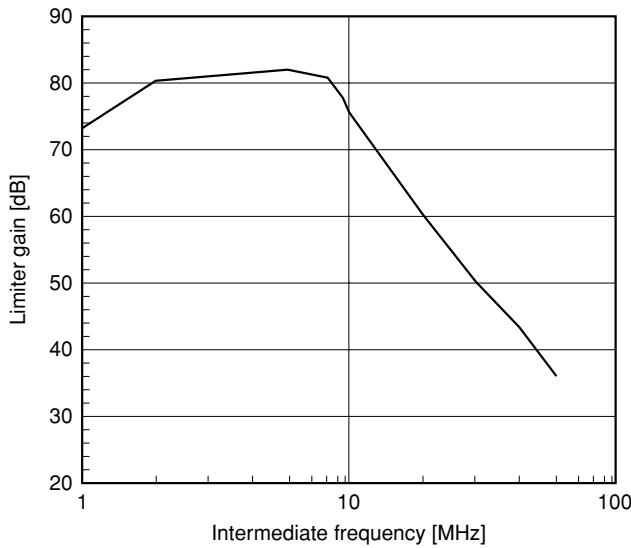

Local oscillation leakage at RFIN pin

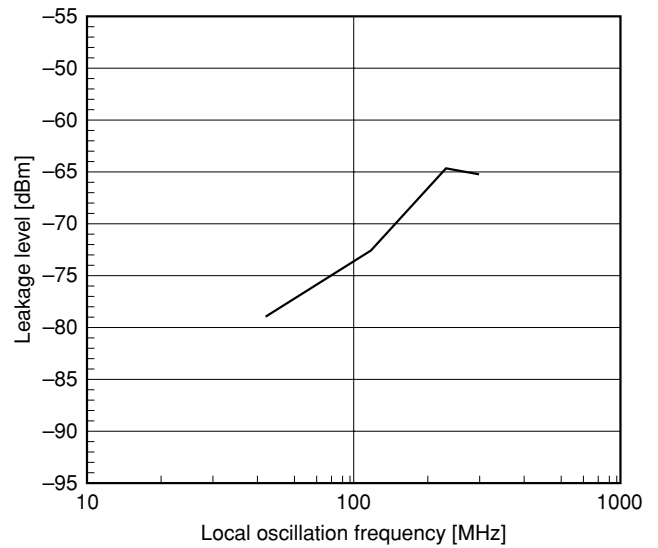

S curve response

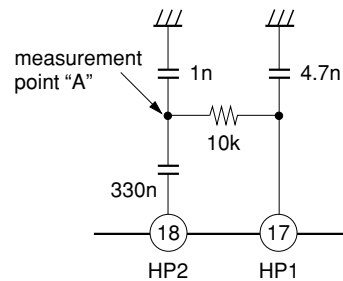
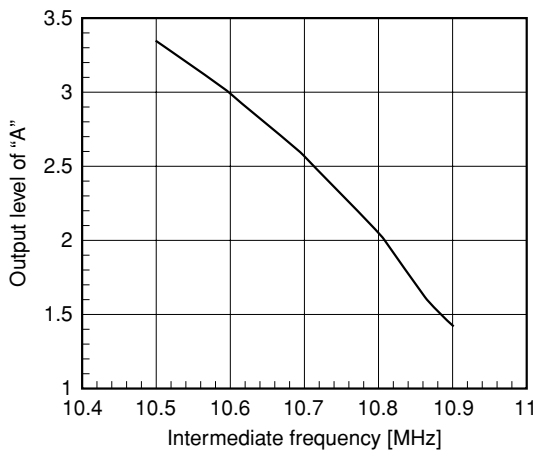

RFIN Input Impedance (Resistance, Capacitance)

Reception frequency	Resistance R ₁	Capacitance C ₁
50 MHz	1.69 kΩ	3.5 pF
100 MHz	1.46 kΩ	3.4 pF
200 MHz	1.08 kΩ	3.4 pF
300 MHz	791 Ω	3.5 pF

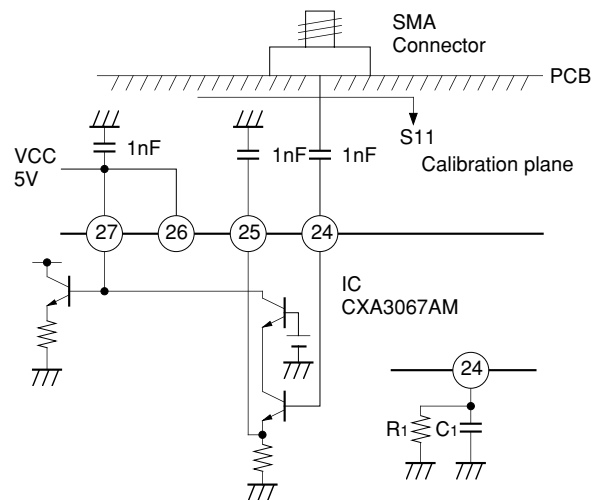
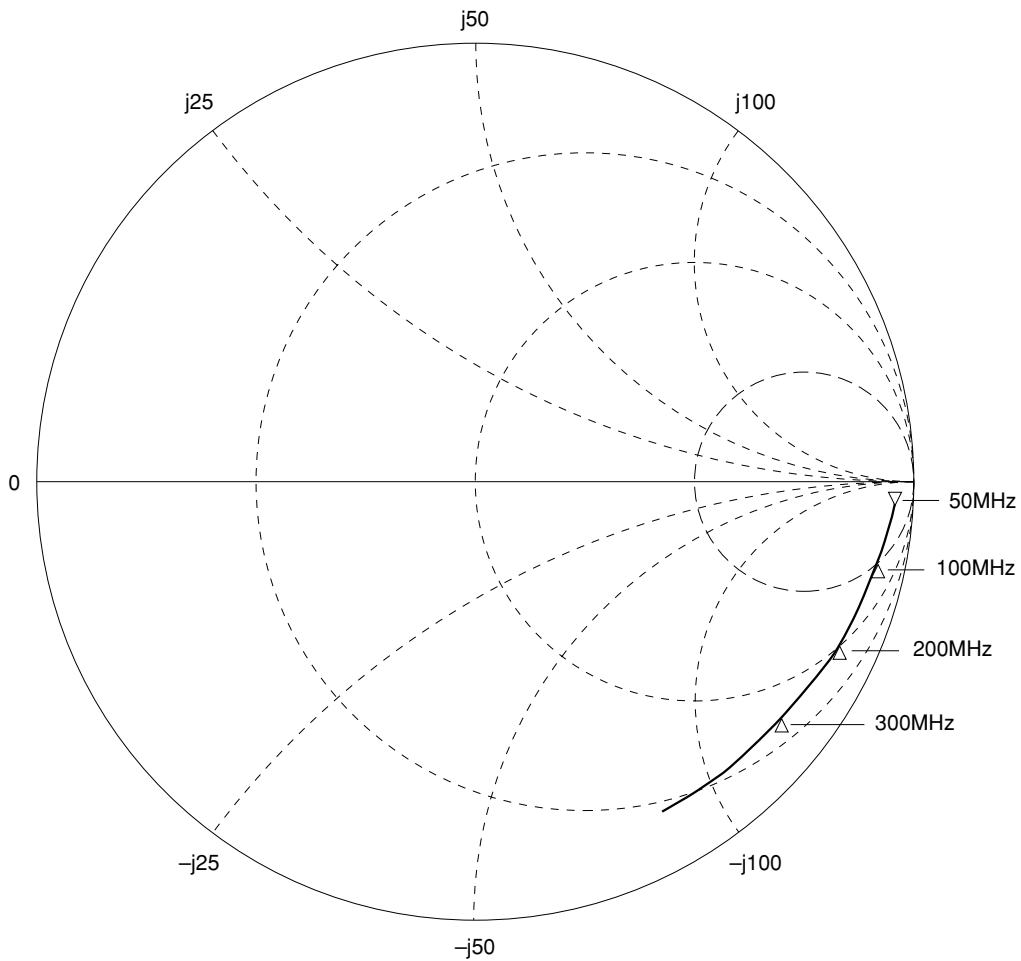

MIXIN Input Impedance (Resistance, Capacitance)

Reception frequency	Resistance R2	Capacitance C2
50 MHz	2.7 kΩ	3.5 pF
100 MHz	2.3 kΩ	3.4 pF
200 MHz	1.6 kΩ	3.4 pF
300 MHz	940 Ω	3.7pF

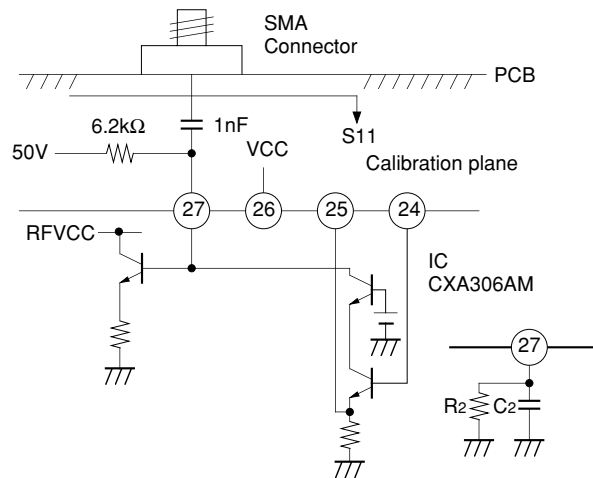
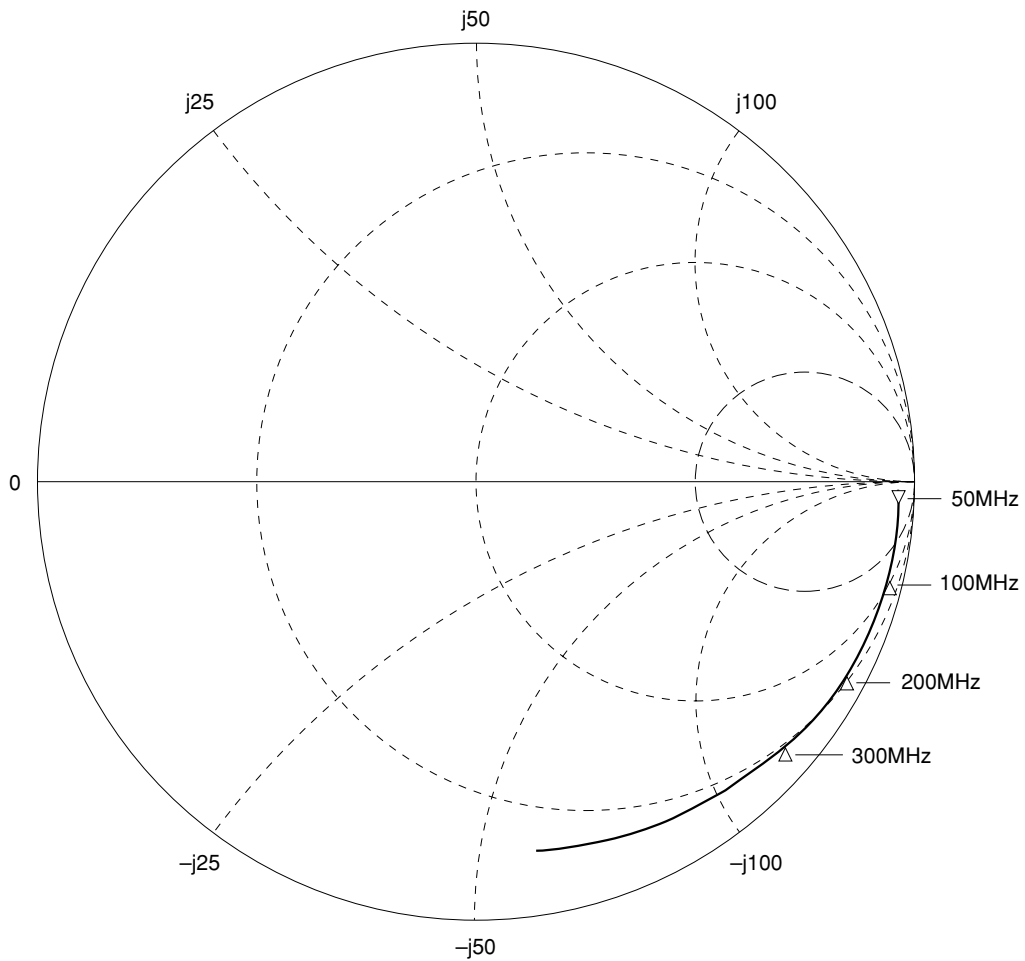

Package Outline Unit : mm

30PIN SOP(PLASTIC)

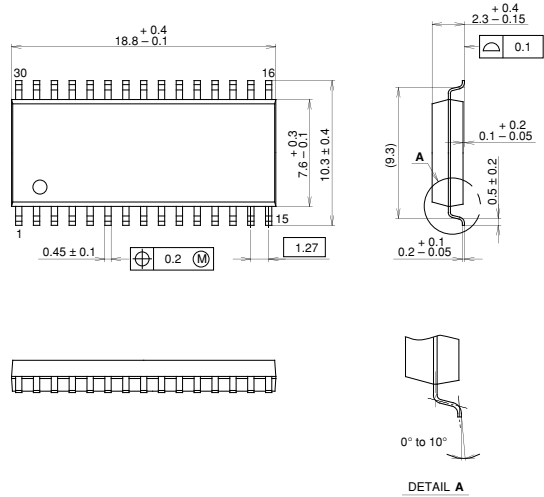

SONY CODE	SOP-30P-L03
EIAJ CODE	SOP030-P-0375
JEDEC CODE	—

PACKAGE STRUCTURE

PACKAGE MATERIAL	EPOXY RESIN
LEAD TREATMENT	SOLDER PLATING
LEAD MATERIAL	COPPER ALLOY
PACKAGE MASS	0.7g

30PIN SOP (PLASTIC)

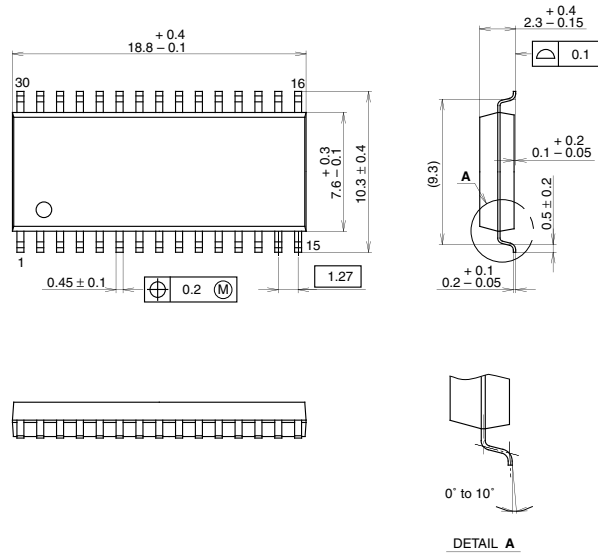

SONY CODE	SOP-30P-L03
EIAJ CODE	SOP030-P-0375
JEDEC CODE	—

PACKAGE STRUCTURE

PACKAGE MATERIAL	EPOXY RESIN
LEAD TREATMENT	SOLDER PLATING
LEAD MATERIAL	COPPER ALLOY
PACKAGE MASS	0.7g

LEAD PLATING SPECIFICATIONS

ITEM	SPEC.
LEAD MATERIAL	COPPER ALLOY
SOLDER COMPOSITION	Sn-Bi Bi:1-4wt%
PLATING THICKNESS	5-18μm



LittleDiode supplies new, hard to find or obsolete electronic components and semiconductors all over the world.

With over two million different components listed you are sure to find the part you need.

Feel free to visit us today at our online store:

LittleDiode.com

Looking forward to providing you with the best possible service.