

## 5-Channel 2-LD Driver for Optical Disc Drive

### Description

The CXA2680ER is a laser driver IC capable of driving two high output lasers (CD/DVD) for writable optical discs.

### Features

- CD write channel maximum drive current: 300mA  
( $V_{CC} = 4.5V$ ,  $V_{OP} = 2.5V$ )
- CD total maximum drive current: 370mA  
( $V_{CC} = 5V$ ,  $V_{OP} = 2.5V$ )
- DVD write channel maximum drive current: 250mA  
( $V_{CC} = 4.5V$ ,  $V_{OP} = 3V$ )
- DVD total maximum drive current: 320mA  
( $V_{CC} = 5V$ ,  $V_{OP} = 3V$ )
- Capable of generating five-value recording waveform through control of five channel
- Rise/Fall times = 1ns
- Read Channel:  $\times 100$
- Write Channel:  $\times 840$  (CD),  $\times 400$  (DVD)
- Read Channel has extensive low-noise design  
 $1.5nA/\sqrt{Hz}$  (@20MHz,  $I_{LD} = 35mA$ ,  $I_{mod} = 20mA_{p-p}$ )
- High frequency modulator circuit
- Frequency variable range: 200 to 600MHz
- Modulator amplitude can be set separately for CD and DVD.
- DVD modulator amplitude switching function
- Timing input for generating recording waveform can be adapted to both differential input (LVDS/LVPECL) and single-end input (3.3V CMOS/TTL).
- Single 5V power supply

### Applications

CD-R, CD-RW, DVD-R, DVD-RW, DVD+R/RW, DVD-ROM and DVD-RAM for high-speed writable optical disc drives

### Structure

Bipolar silicon monolithic IC

32 pin VQFN (Plastic)

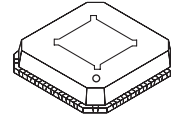

### Absolute Maximum Ratings

• Supply voltage	$V_{CC}$	5.5	V
• Storage temperature	$T_{STG}$	-65 to +150	°C
• Allowable power dissipation	$P_D$	TBD	mW

### Operating Conditions

• Supply voltage	$V_{CC}$	4.5 to 5.5	V
• Operating temperature	$T_{OPR}$	-10 to +75	°C

Sony reserves the right to change products and specifications without prior notice. This information does not convey any license by any implication or otherwise under any patents or other right. Application circuits shown, if any, are typical examples illustrating the operation of the devices. Sony cannot assume responsibility for any problems arising out of the use of these circuits.

Block Diagram and Pin Configuration

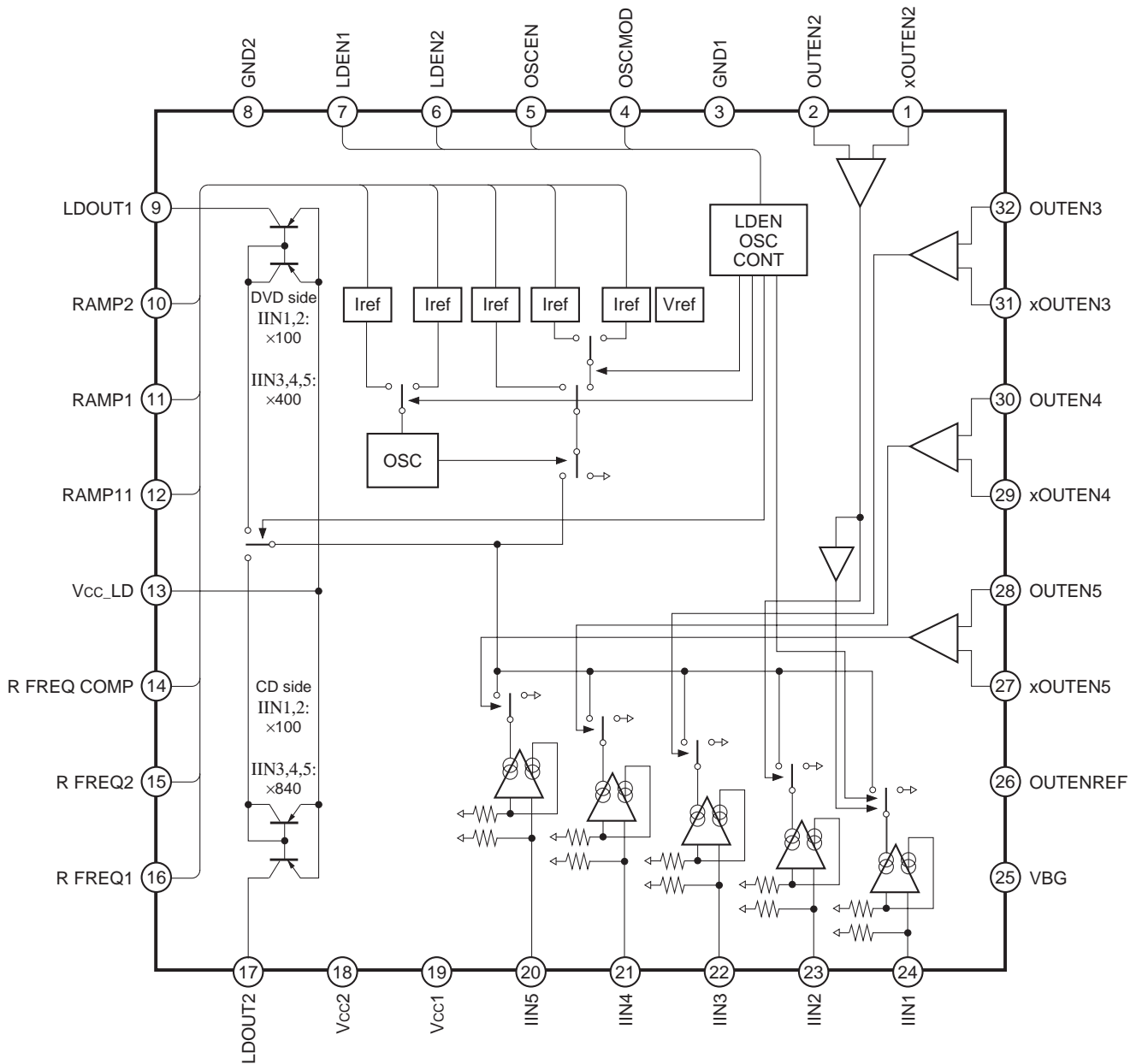

Pin Description

Pin No.	Symbol	I/O	Pin voltage	Equivalent circuit	Description
1	xOUTEN2	I	—		IIN1 or IIN2 set current control signal input.
2	OUTEN2	I	—		IIN1 or IIN2 set current control signal input.
27	xOUTEN5	I	—		IIN5 set current control signal input. (negative logic)
28	OUTEN5	I	—		IIN5 set current control signal input. (positive logic)
29	xOUTEN4	I	—		IIN4 set current control signal input. (negative logic)
30	OUTEN4	I	—		IIN4 set current control signal input. (positive logic)
31	xOUTEN3	I	—		IIN3 set current control signal input. (negative logic)
32	OUTEN3	I	—		IIN3 set current control signal input. (positive logic)
3	GND1	—	—	—	Ground.
4	OSCMOD	I	—		DVD modulator amplitude switching control signal. When OSCMOD = high, RAMP1 is selected. When OSCMOD = low, RAMP11 is selected.
5	OSCEN	I	—		Modulator control signal. (positive logic) When OSCEN = high, the modulator waveform is output.
6	LDEN2	I	—		CD output control. (positive logic)
7	LDEN1	I	—		DVD output control. (positive logic)
8	GND2	—	—	—	Ground.
9	LDOUT1	O	—		DVD laser drive current output. Enabled when LDEN 1 = high and LDEN2 = low.

Pin No.	Symbol	I/O	Pin voltage	Equivalent circuit	Description
10	RAMP2	O	—		Modulator amplitude setting 2. Enabled when LDEN1 = low and LDEN2 = high. Connects resistance to ground.
11	RAMP1	O	—		Modulator amplitude setting 1. Enabled when LDEN1 = high, LDEN2 = low and OSCMOD = high. Connects resistance to ground.
12	RAMP11	O	—		Modulator amplitude setting 11. Enabled when LDEN1 = high, LDEN2 = low and OSCMOD = low. Connects resistance to ground.
13	Vcc_LD	—	—	—	Output stage supply voltage.
14	R FREQ COMP	O	—		Modulator frequency variation adjustment. Connects resistance to ground.
15	R FREQ2	O	—		Modulator frequency setting 2. Enabled when LDEN1 = low and LDEN2 = high. Connects resistance to ground.
16	R FREQ1	O	—		Modulator frequency setting 1. Enabled when LDEN1 = high and LDEN2 = low. Connects resistance to ground.
17	LDOUT2	O	—		CD laser drive current output. Enabled when LDEN1 = low and LDEN2 = high.
18	Vcc2	I	—	—	Supply voltage for timing system and current switch.
19	Vcc1	I	—	—	Supply voltage for control system and modulator system.
20	IIN5	I	—		Current setting 5.
21	IIN4	I	—		Current setting 4.
22	IIN3	I	—		Current setting 3.

Pin No.	Symbol	I/O	Pin voltage	Equivalent circuit	Description
23	IIN2	I	—		Current setting 2.
24	IIN1	I	—		Current setting 1.
25	VBG	O	1.26V		Internal reference voltage decoupling.
26	OUTENREF	O	1.65V		Reference voltage output for current control signal. Connects resistance to ground.

## Electrical Characteristics

(V<sub>CC</sub> = 5V, T<sub>a</sub> = 25°C)

No.	Measurement item	Symbol	Min.	Typ.	Max.	Unit	Condition
1	Current consumption 1	I <sub>CC1</sub>	5.5	8.5	11.5	mA	LDEN1, 2 = L
2	Current consumption 2	I <sub>CC2</sub>	90	130	170	mA	LDEN1 = H, IOUT1 = 60mA, OSCEN = H, AMP = 40mAp-p
3	Current consumption 3	I <sub>CC3</sub>	130	190	250	mA	LDEN = H, IOUT1 = 60mA, IOUT3 = 120mA (Duty = 25%), IOUT4 = 60mA (Duty = 50%), IOUT = IOUT1 + IOUT3 + IOUT4
4	Current consumption 3-1	I <sub>CC3_1</sub>	105	150	195	mA	LDEN = H, IOUT1 = 30mA, IOUT3 = 120mA (Duty = 25%), IOUT4 = 60mA (Duty = 50%), IOUT = IOUT1 + IOUT3 + IOUT4
<b>&lt;Logic input block: During single end transfer&gt;</b>							
5	Input voltage high level	V <sub>SH</sub>	2	—	V <sub>CC</sub>	V	
6	Input voltage low level	V <sub>SL</sub>	GND	—	1.3	V	
<b>&lt;Logic input block: During differential input&gt;</b>							
7	Input voltage high level	V <sub>DH</sub>	0.8		3	V	
8	Input voltage amplitude	V <sub>DL</sub>	0.2		3	V	
<b>&lt;LD driver block: DC&gt;</b>							
9	LD drive current 1, 2	I <sub>OUTR</sub>	100		—	mA	
10	LD drive current 3, 4, 5 (DVD)	I <sub>OUTW1</sub>	250		—	mA	
11	LD drive current 3, 4, 5 (CD)	I <sub>OUTW2</sub>	300		—	mA	
12	Total LD drive current 1 (DVD)	I <sub>OUT1</sub>	320		—	mA	V <sub>CC</sub> = 5V, V <sub>OP</sub> = 3V
13	Total LD drive current 2 (CD)	I <sub>OUT2</sub>	370		—	mA	V <sub>CC</sub> = 5V, V <sub>OP</sub> = 2.5V
14	Minimum LD drive current 1 (DVD)	OFFSET1	—	—	5	mA	I <sub>IN</sub> = 0μA, LDEN1 = OUTEN2 = OUTEN3 = OUTEN4 = OUTEN5 = H
15	Minimum LD drive current 2 (CD)	OFFSET2	—	—	5	mA	I <sub>IN</sub> = 0μA, LDEN2 = OUTEN2 = OUTEN3 = OUTEN4 = OUTEN5 = H
16	Output current noise 1	NOISE1	—	1.5	—	nA/√Hz	f = 400MHz, I <sub>LD</sub> = 35mA, I <sub>mod</sub> = 20mAp-p (20MHz: NOISE)
17	Output current noise 2	NOISE2	—	1.5	—	nA/√Hz	f = 400MHz, I <sub>LD</sub> = 35mA, I <sub>mod</sub> = 20mAp-p (20MHz: NOISE)

No.	Measurement item	Symbol	Min.	Typ.	Max.	Unit	Condition
<b>&lt;LD driver block: Pulse driving&gt;</b>							
18	Propagation delay	DELAY	—	3	—	ns	
19	Rise time (Tr)	TR	—	1.5	—	ns	I <sub>LD</sub> = 50 to 100mA pulse Settling 10 to 90% (resistance load)
20	Fall time (Tf)	TF	—	1.5	—	ns	I <sub>LD</sub> = 100 to 50mA pulse Settling 10 to 90% (resistance load)
<b>&lt;ILD control block&gt;</b>							
21	Input resistance 1 (Pins 23, 24)	ZIINR	0.56	0.8	1.04	kΩ	
22	Input resistance 2 (Pins 20, 21, 22)	ZIINW	1.05	1.5	1.95	kΩ	
23	Input/output gain 1, 2	GAINR	95	105	115	—	
24	Input/output gain 3, 4, 5 (DVD)	GAINW1	360	400	440	—	
25	Input/output gain 3, 4, 5 (CD)	GAINW2	765	840	935	—	
26	ILD control linearity 1 (DVD)	LINEA1	-3.5	—	2.5	%	Based on linearity when I <sub>LD</sub> = 50 to 150mA V <sub>CC</sub> = 4.5V, V <sub>1</sub> = 1.75V, R <sub>L</sub> = 5Ω, I <sub>LD</sub> = 250mA
27	ILD control linearity 2 (CD)	LINEA2	-3.5	—	2.5	%	Based on linearity when I <sub>LD</sub> = 50 to 150mA V <sub>CC</sub> = 4.5V, V <sub>1</sub> = 1V, R <sub>L</sub> = 5Ω, I <sub>LD</sub> = 300mA
28	Input/output R gain relative precision 1		-5	—	5	%	I <sub>IIN1</sub> = I <sub>IIN2</sub> = 250μA I <sub>IIN2</sub> output current precision based on I <sub>IIN1</sub> output current
29	Input/output R gain relative precision 2		-5	—	5	%	I <sub>IIN1</sub> = I <sub>IIN2</sub> = 500μA I <sub>IIN2</sub> output current precision based on I <sub>IIN1</sub> output current
30	Input/output R gain relative precision 3		-5	—	5	%	I <sub>IIN1</sub> = I <sub>IIN2</sub> = 750μA I <sub>IIN2</sub> output current precision based on I <sub>IIN1</sub> output current
31	Input/output W gain relative precision	GACCU	-5	—	5	%	
32	Input/output transmission band	FBAND	7	—	—	MHz	Frequency for input/output gain of -3dB
<b>&lt;High frequency modulator&gt;</b>							
33	Lowest oscillation frequency	FREQL	—	200	—	MHz	
34	Highest oscillation frequency	FREQH	—	600	—	MHz	
35	Amplitude variable range	VARIAMP	—	—	100	mAp-p	f <sub>mod</sub> = 400MHz
36	Frequency variation	FREQ	-10	—	10	%	f <sub>mod</sub> = 400MHz
37	Frequency temperature characteristic	TFREQ	—	319	—	%	f <sub>mod</sub> = 300MHz
38	Amplitude variation	AMP	20	31	42	mAp-p	f <sub>mod</sub> = 400MHz,
39	Amplitude temperature characteristic	TAMP	—	116	—	%	f <sub>mod</sub> = 300MHz, RAMP = 10kΩ
40	OSCEN response time (ON)	OSCRES1	—	5	—	ns	
41	OSCEN response time (OFF)	OSCRES2	—	5	—	ns	

No.	Measurement item	Symbol	Min.	Typ.	Max.	Unit	Condition
<b>&lt;LDEN control&gt;</b>							
42	LDEN response time 1 (ON)	RLDRES1	—	—	700	ns	Time to reach 90% of Read set current (same condition as current consumption 2)
43	LDEN response time 1 (OFF)	RLDRES2	—	—	10	ns	Time to reach 10% of Read set current (same condition as current consumption 2)
44	LDEN response time 2 (ON)	WLDRES1	—	—	700	ns	Time to reach 90% of Write set current (same condition as current consumption 3)
45	LDEN response time 2 (OFF)	WLDRES2	—	—	10	ns	Time to reach 10% of Write set current (same condition as current consumption 3)

Electrical Characteristics Measurement Circuit

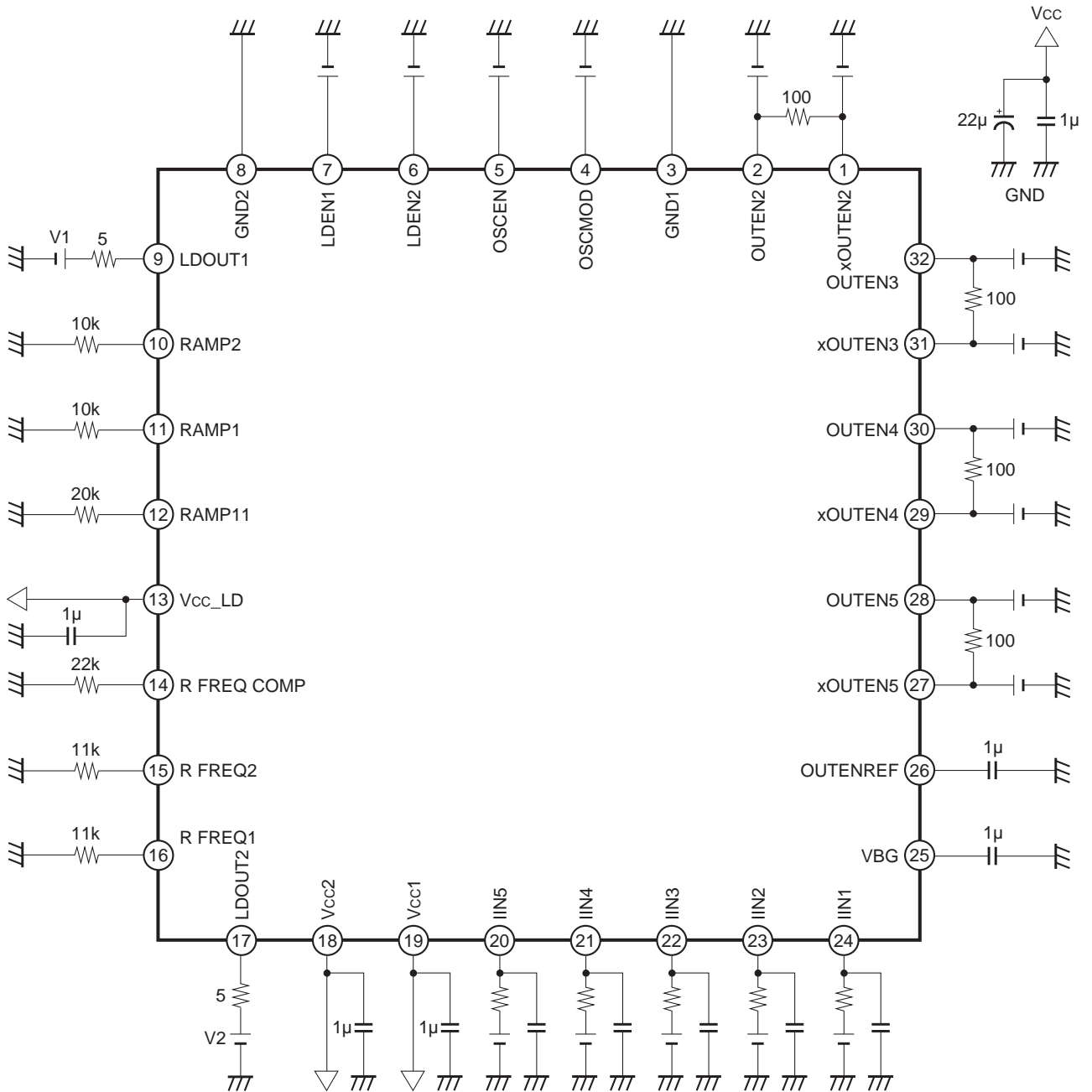

**Description of Operation**

**(1) LD Drive Current Value Setting**

The current controlled by the current setting pins IIN1, IIN2, IIN3, IIN4 and IIN5 is output from the LDOUT1 and LDOUT2 pins. IIN1, IIN2, IIN3, IIN4 and IIN5 can be set respectively by OUTEN and xOUTEN for the output drive current from the LDOUT pin.

**(2) Differential Input and Single-end Input**

External processing is required for the differential input and single-end input switching. For the single-end input, if the device is used at the active Low, the OUTENREF pin and the OUTEN pin should be shorted externally; if it is used at the active High, the OUTENREF pin and the xOUTEN pin should be shorted externally. Leave the OUTENREF pin open for the differential input.

**(3) Modulator Circuit**

The modulator ON/OFF is controlled by the OSCEN pin. For the DVD side, the modulator frequency is varied by the external resistor connected to the RFREQ1 pin and the modulator amplitude can be varied by the external resistor value connected to the RAMP1 pin when the OSCMOD is high, and the RAMP11 pin when it is low. For the CD side, the modulator frequency is varied by the external resistor connected to the RFREQ2 pin and the modulator amplitude can be varied by the external resistor value connected to the RAMP2 pin.

**(4) R FREQ COMP Pin**

The current depending on the internal resistor is generated using the R FREQ COMP pin external resistor to suppress the dispersion of the modulator frequency depending on the internal resistor. The R FREQ COMP pin external resistor is recommended to be fixed to 22kΩ.

**(5) Modulator Level Adjustment**

The modulator level adjustment can be performed by varying the IIN1 input current value.

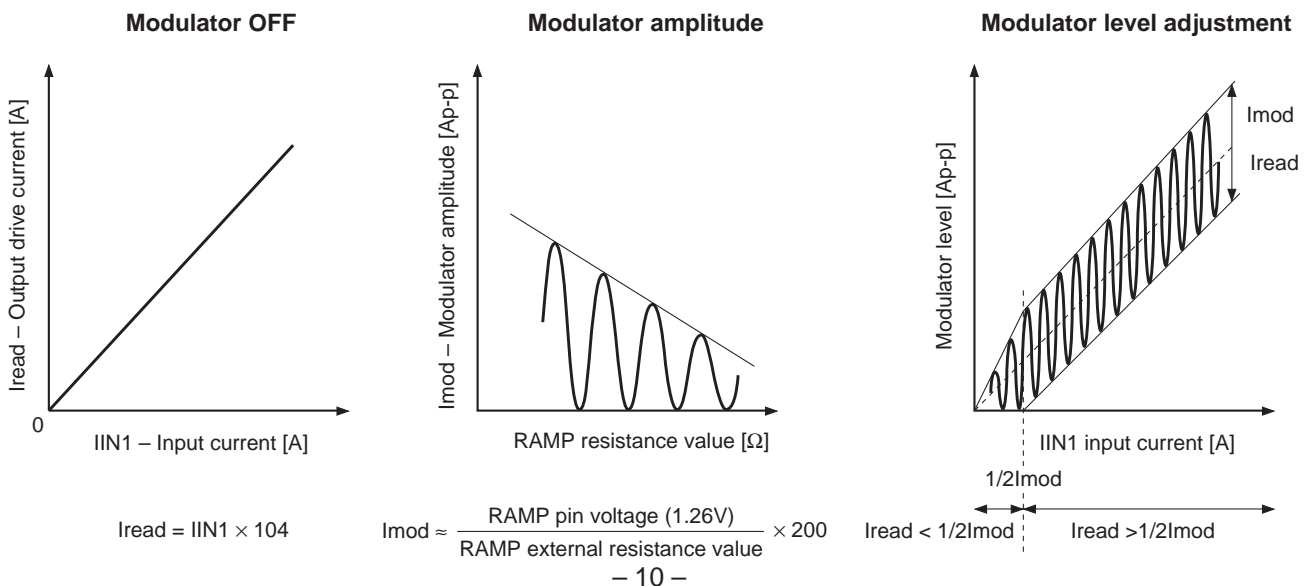

**(6) IIN2 I/O Characteristics**

The read block is comprised of the two channels of IIN1 (Bias Power) and IIN2 (Cool Power). Assign IIN2 to the Cool Power setting channel.

When IIN1 = IIN2, the IIN2 I/O characteristics are the same as IIN1.

When IIN1 > IIN2, that is to say when IIN2 = IIN1 - ΔI, the IIN2 I/O characteristics are the same as IIN1 except for the low current area (Icool < 1/2Imod) that depends on the IIN2 input current value and the RAMP external resistor value.

When IIN1 < IIN2, that is to say when IIN2 = IIN1 + ΔI, the IIN2 I/O characteristics are the same as IIN1 except for the low current area (Iread < 1/2Imod) that depends on the IIN1 input current value and the RAMP external resistor value.

For actual use, this is not a problem as long as the RAMP external resistor value is 10kΩ or more so that the low current area where a difference occurs in the IIN1 and IIN2 I/O characteristics is the LD Ith or less.

(1/2Imod = 12.6mA at 10kΩ)

In addition, switching to the larger of the RAMP1 pin and RAMP11 pin external resistor values with the OSCMOD pin is also effective.

**IIN1 I/O characteristics (IIN1 = Sweep, IIN2 = 0)**

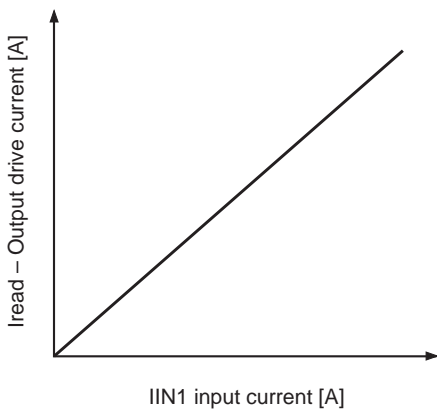

**IIN2 I/O characteristics (IIN1 = IIN2 = Sweep)**

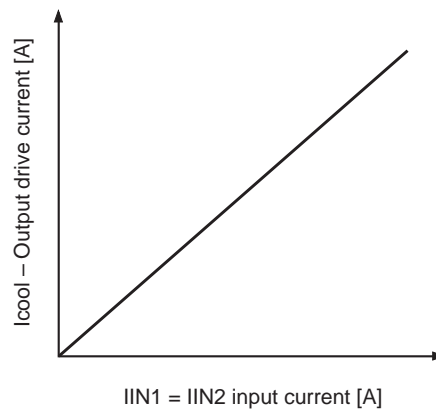

**IIN2 I/O characteristics (IIN1 = Sweep, IIN2 = IIN1 - ΔI)**

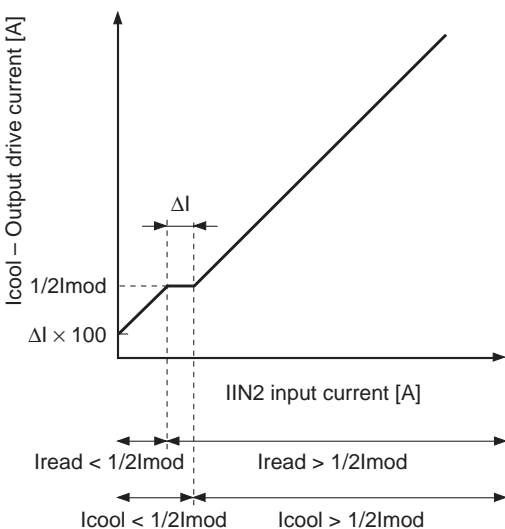

**IIN2 I/O characteristics (IIN1 = Sweep, IIN2 = IIN1 + ΔI)**

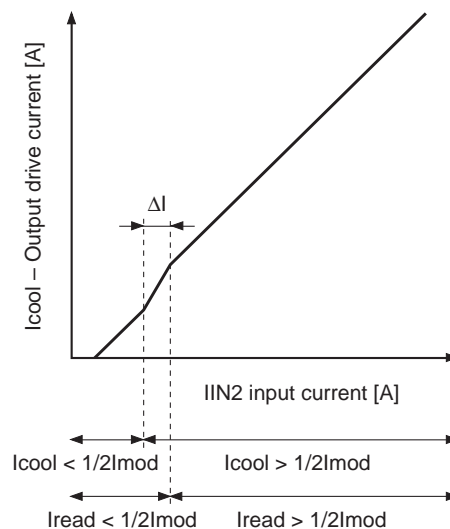

## Description of Functions

## 1. Logic Table

## Output control

		IN1/IN2	IN3	IN4	IN5				
LDEN1	LDEN2	xOUTEN2	xOUTEN3	xOUTEN4	xOUTEN5	OSCEN	OSCMOD	LDOUT1 (DVD)	LDOUT2 (CD)
L	L	X	X	X	X	X	X	OFF	OFF
H	L	H	H	H	H	L	L	IIN1 × 100	OFF
H	L	L	H	H	H	L	L	IIN2 × 100	OFF
H	L	H	L	H	H	L	L	IIN1 × 100 + IIN3 × 400	OFF
H	L	H	H	L	H	L	L	IIN1 × 100 + IIN4 × 400	OFF
H	L	H	H	H	L	L	L	IIN1 × 100 + IIN5 × 400	OFF
H	L	H	L	L	L	L	L	IIN1 × 100 + (IIN3 + IIN4 + IIN5) × 400	OFF
L	H	H	H	H	H	L	L	OFF	IIN1 × 100
L	H	L	H	H	H	L	L	OFF	IIN2 × 100
L	H	H	L	H	H	L	L	OFF	IIN1 × 100 + IIN3 × 840
L	H	H	H	L	H	L	L	OFF	IIN1 × 100 + IIN4 × 840
L	H	H	H	H	L	L	L	OFF	IIN1 × 100 + IIN5 × 840
L	H	H	L	L	L	L	L	OFF	IIN1 × 100 + (IIN3 + IIN4 + IIN5) × 840
H	H	X	X	X	X	X	X	OFF (INHIBIT)	OFF (INHIBIT)

## Module control

LDEN1	LDEN2	xOUTEN2	xOUTEN3	xOUTEN4	xOUTEN5	OSCEN	OSCMOD	LDOUT1	LDOUT2
L	L	X	X	X	X	X	X	OFF	OFF
H	L	X	X	X	X	L	H	MODOFF	OFF
H	L	X	X	X	X	H	H	MODON (R FREQ1, RAMP1)	OFF
H	L	X	X	X	X	H	L	MODON (R FREQ1, RAMP11)	OFF
L	H	X	X	X	X	L	X	OFF	MODOFF
L	H	X	X	X	X	H	X	OFF	MODON (R FREQ2, RAMP2)
H	H	X	X	X	X	X	X	OFF (INHIBIT)	OFF (INHIBIT)

**Note:** Module control does not depend on a data timing signals.

2. Timing Chart

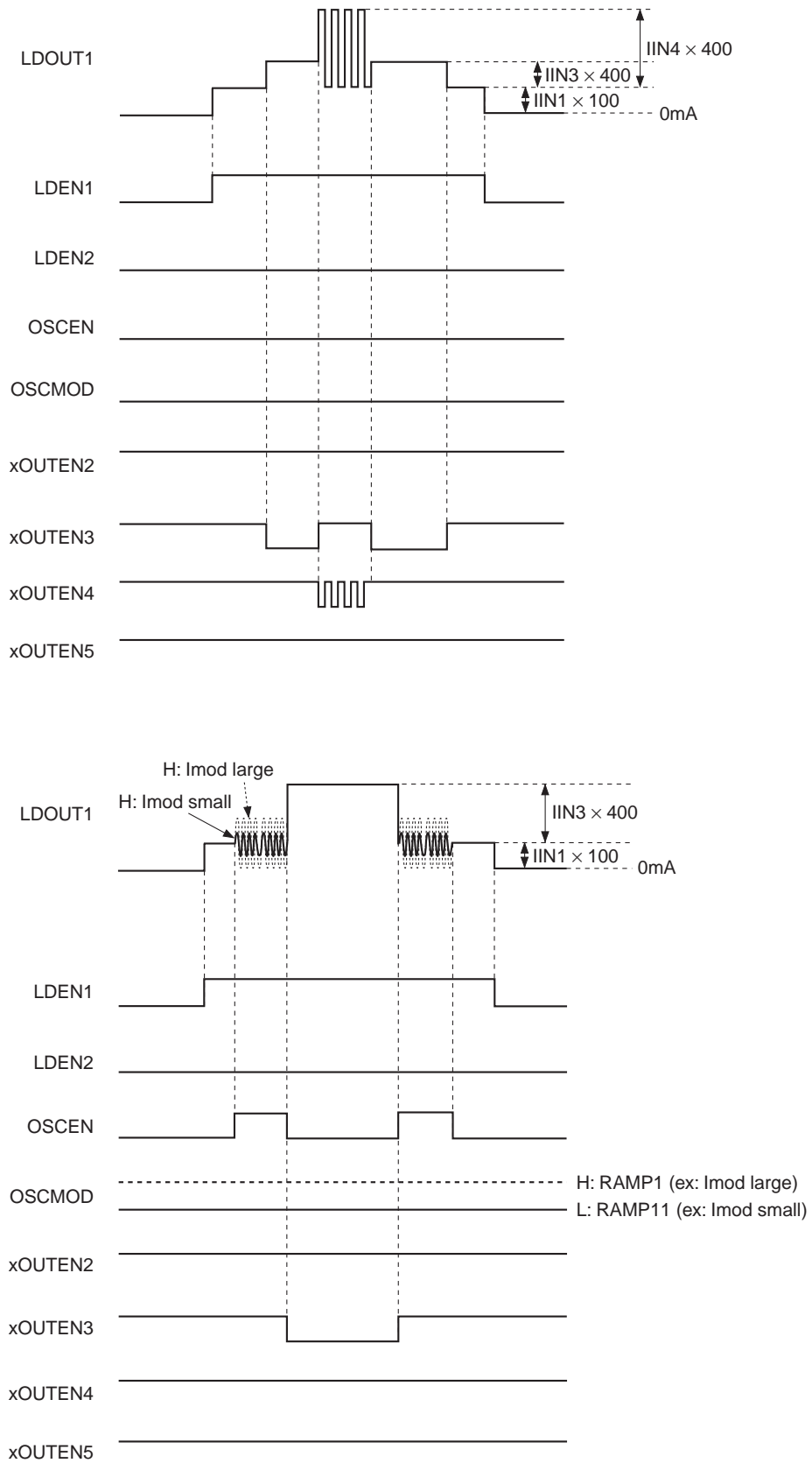

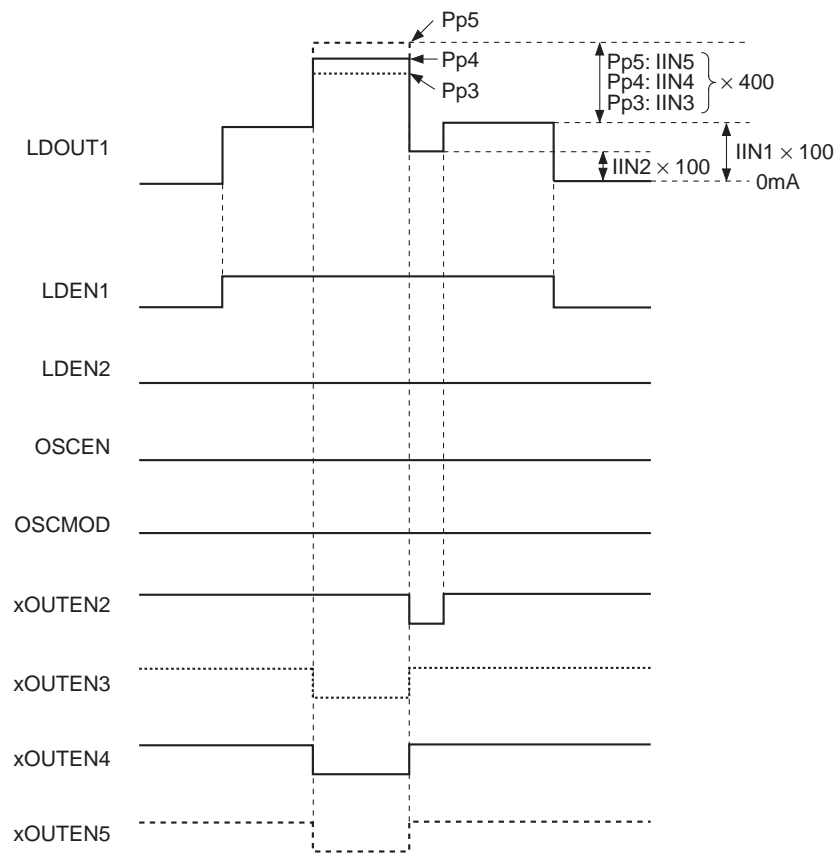

## Notes on Operation

- Arrange the external resistors connected to the IIN1, IIN2, IIN3, IIN4 and IIN5 pins near the IC package to reduce the affects from other signal lines.
- Wiring between the output LDOUT pin and the laser diode, and wiring between the Vcc\_LD pin and external decoupling capacitors should be the shortest. Making the distance for wiring long increases output waveform overshoots and undershoots caused by the affect of wiring inductance.
- The Vcc\_LD pin's external decoupling capacity ground can be grounded to the GND grounding the load from the LDOUT pin. This reverses the phase of the drive waveform at the LDOUT and Vcc\_LD and moves in the direction that suppresses overshoots and undershoots.

- Temperature guarantee

Thermal resistance ( $\theta_{j-a}$ ) when the CXA2680ER is mounted on PWB varies according to the set (PWB) and because it is difficult to predict along with the tendency for higher power for power consumption ( $P_o$ ), the following points should be considered when using.

Use in a range that does not exceed a junction temperature of 150°C. Also, power consumption ( $P_o$ ) should be below allowable power dissipation ( $P_D$ ). Use with the thermal resistance ( $\theta_{j-a}$ ) of the PWB mounting lowered so that it can be operated normally at a maximum operating temperature of 75°C. To lower  $\theta_{j-a}$ , radiating measures on the set, such as widening the GND region with the set PWB are needed. Also, the die-pad on the CXA2680ER 32-pin VQFN package is exposed on the backside, so thermal transmission from the IC surface is excellent. For that reason, it is possible to release heat to the set chassis thereby lowering the thermal resistance of the PWB mount.

Find the thermal resistance ( $\theta_{j-a}$ ) when mounted on PWB and power consumption ( $P_o$ ) using the following method.

$$P_o = (I_{cc} \times V_{cc}) - (I_{op} \times V_{op})$$

$I_{cc}$ : IC current consumption when operating (Including  $I_{op}$ )

$I_{op}$ : Output drive current flowed from the LDOUT pin to the Laser Diode

$V_{op}$ : Operating voltage of the laser diode

It is also possible for  $P_o$  when a modulator is ON ( $I_{mod} = 40\text{mA}_{p-p}$ ), although the precision will decrease.

On the DVD side:  $P_o = (60\text{mA} + IIN1 \times 2.6 + (IIN3 + IIN4 + IIN5) \times 10) \times V_{cc} + (I_{op} \times (V_{cc} - V_{op}))$

On the CD side:  $P_o = (60\text{mA} + IIN1 \times 2.6 + (IIN3 + IIN4 + IIN5) \times 21) \times V_{cc} + (I_{op} \times (V_{cc} - V_{op}))$

**Thermal resistance ( $\theta_{j-a}$ ) when mounted on PWB**

- The thermal resistance ( $\theta_{c-a}$ ) is obtained by measuring the Package surface temperature using a thermo couple or a radiation thermometer.

In order to improve the precision of measurement, it is desired to calculate by the following formula.

$\Delta$ Package surface temperature when  $I_{op}$  is variable/ $\Delta P_o$

Assume the thermal resistance ( $\theta_{j-c}$ ) to be approximately 2°C/W.

- Diode thermal coefficient  $-2.27mV/^\circ C$  and the positive protection diode thermal characteristics are used to find this.

The  $V_2$  voltage found in (2) below cancels the voltage decrease caused by the wiring resistance between the positive protection diode connection  $V_{cc}$  and the  $V_{cc}$  pins as reference and is measured to find the precise temperature characteristics of the positive protection diode.

- (1)  $V_1$  to OSCEN pin voltage to  $V_{cc}$  pin voltage,  $I_{cc1}$  to current consumption when 0V is applied to the IIN1, IIN2, IIN3, IIN4 and IIN5 pins.
- (2)  $V_2$  to OSCEN pin voltage to  $V_{cc}$  pin voltage immediately after applying the arbitrary voltage to the IINx pin.
- (3)  $V_3$  to OSCEN pin voltage to  $V_{cc}$  pin voltage,  $I_{cc3}$  to consumption current when applying the arbitrary voltage to the IINx pin and heat reaches equilibrium.

$\Delta T_j$  using the voltage drop ( $V_1$  to  $V_2$ ) between the positive protection diode connection  $V_{cc}$  and the  $V_{cc}$  pins that are the reference, as described above are:

$$\Delta T_j = ((V_3 + (V_1 - V_2)) - V_1) / -2.27mV/^\circ C$$

Thermal resistance ( $\theta_{j-a}$ ) is:

$$\theta_{j-a} = \Delta T_j / ((I_{cc3} - I_{cc1}) \times V_{cc} - I_{op} \times V_{op})$$

- Allowable power dissipation ( $P_D \geq P_o$  [W])

$$P_D = (150^\circ C - \text{Ambient temperature}) / \theta_{j-a}$$

- Maximum operating temperature 75°C

$$(150^\circ C - \Delta T_j) \geq 75^\circ C$$

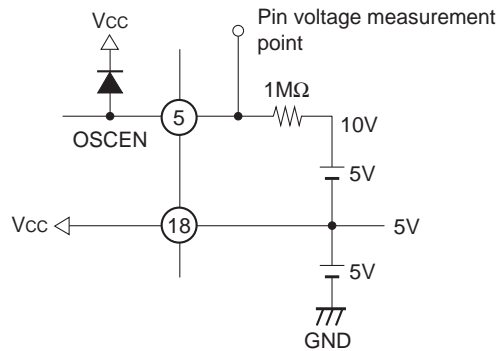

Example of Representative Characteristics

**IIN1 input current vs. CD/DVD output current characteristics**  
 Vcc = 5V, resistance load

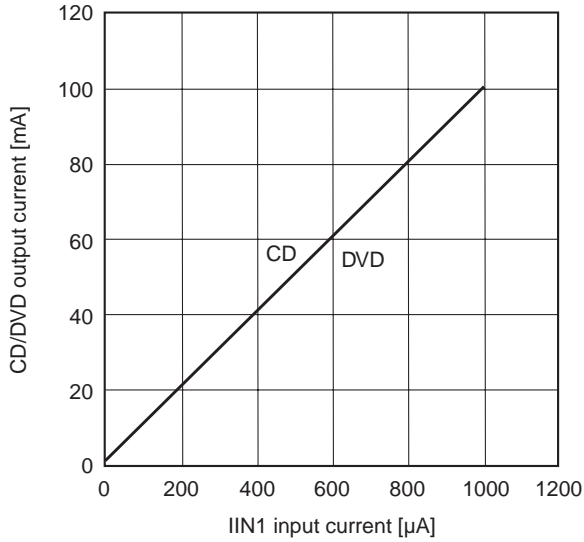

**IIN3, IIN4, IIN5 input current vs. CD/DVD output current characteristics**  
 Vcc = 5V, resistance load

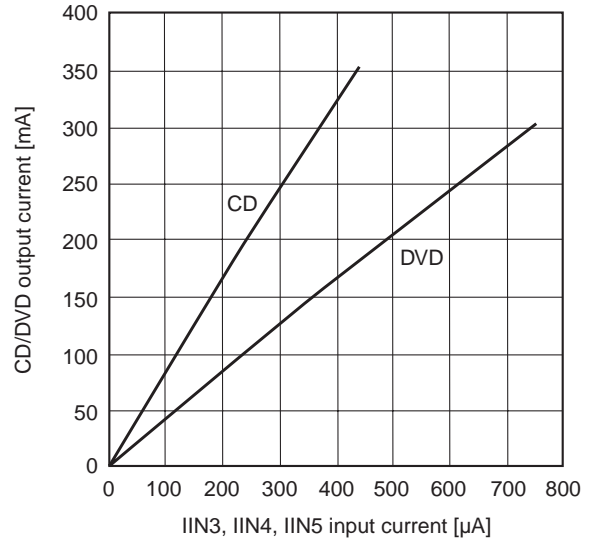

**Modulator frequency control characteristics**  
 RAMP = 3.3kΩ (approximately 40mAp-p)  
 R FREQ COMP = 22kΩ, IIN1 = 642µA

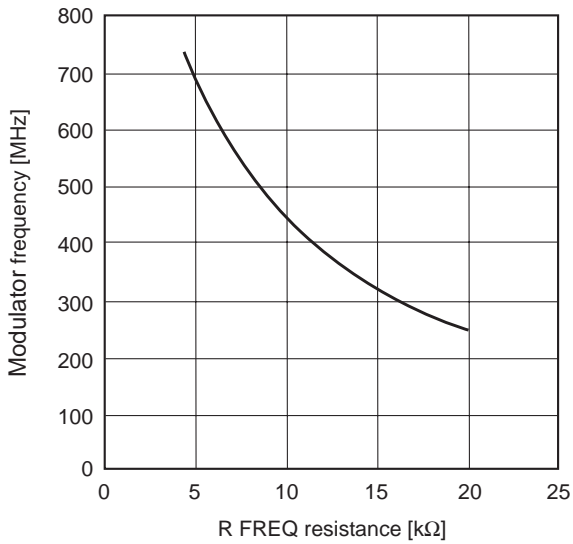

**RAMP resistance value vs. Modulator waveform peak current characteristics**  
 R FREQ = 12kΩ (approximately 390MHz)  
 R FREQ COMP = 22kΩ, IIN1 = 642µA

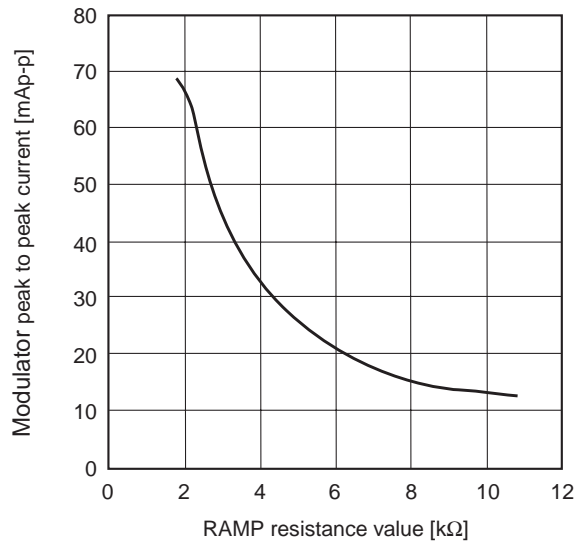

Application Circuit 1

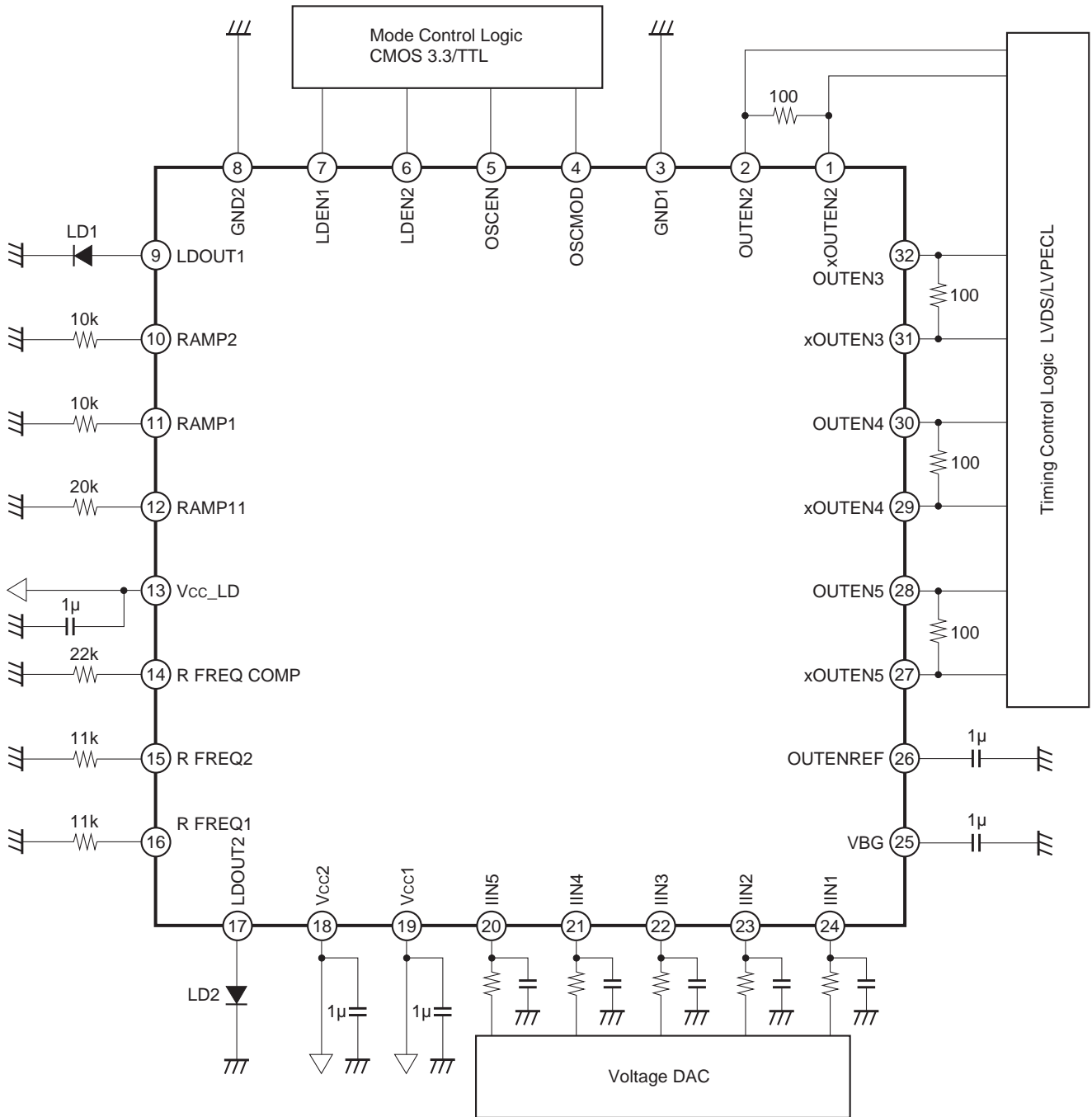

Application circuits shown are typical examples illustrating the operation of the devices. Sony cannot assume responsibility for any problems arising out of the use of these circuits or for any infringement of third party patent and other right due to same.

Application Circuit 2

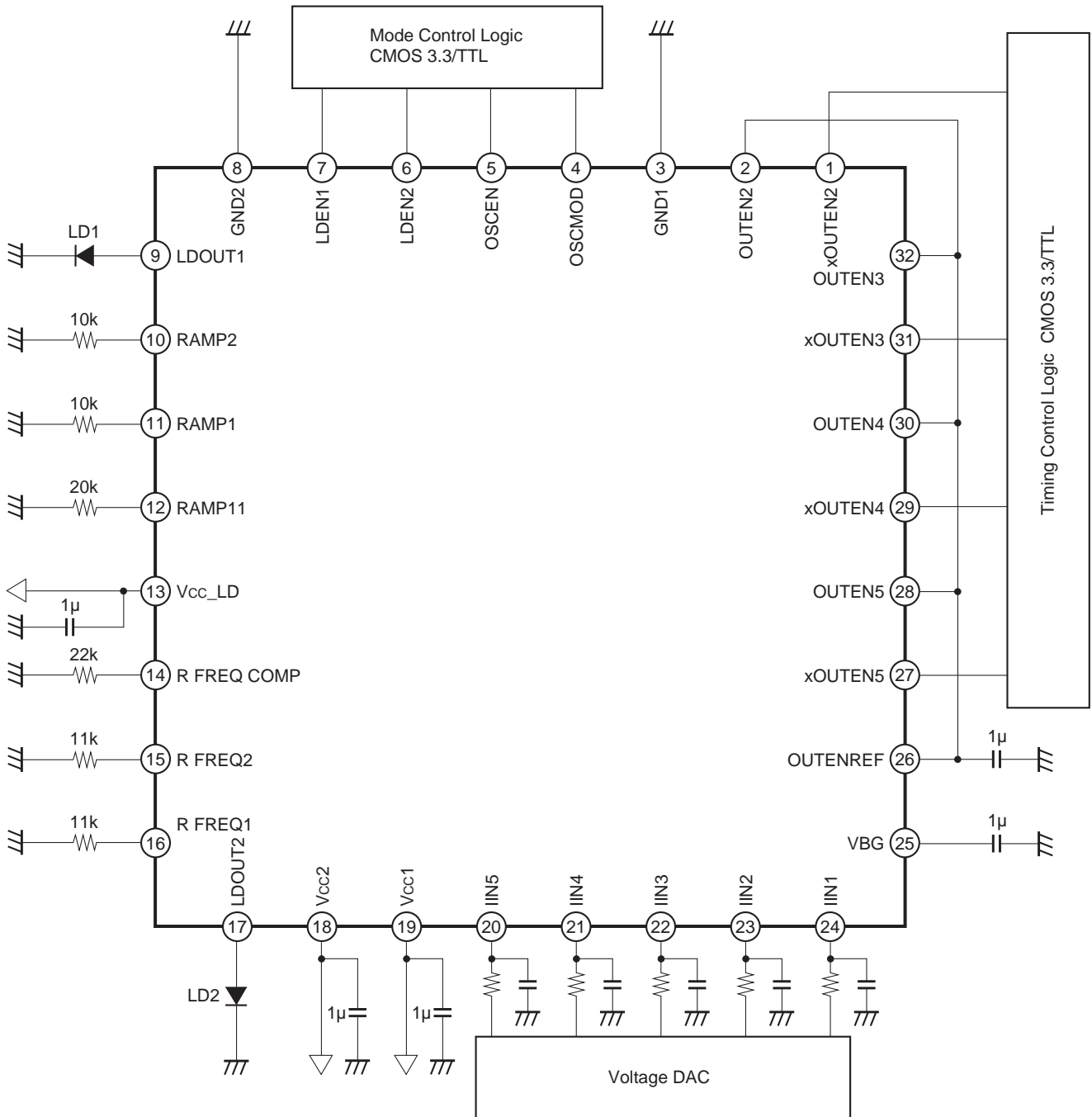

Application circuits shown are typical examples illustrating the operation of the devices. Sony cannot assume responsibility for any problems arising out of the use of these circuits or for any infringement of third party patent and other right due to same.

Package Outline Unit: mm

32PIN VQFN (PLASTIC)

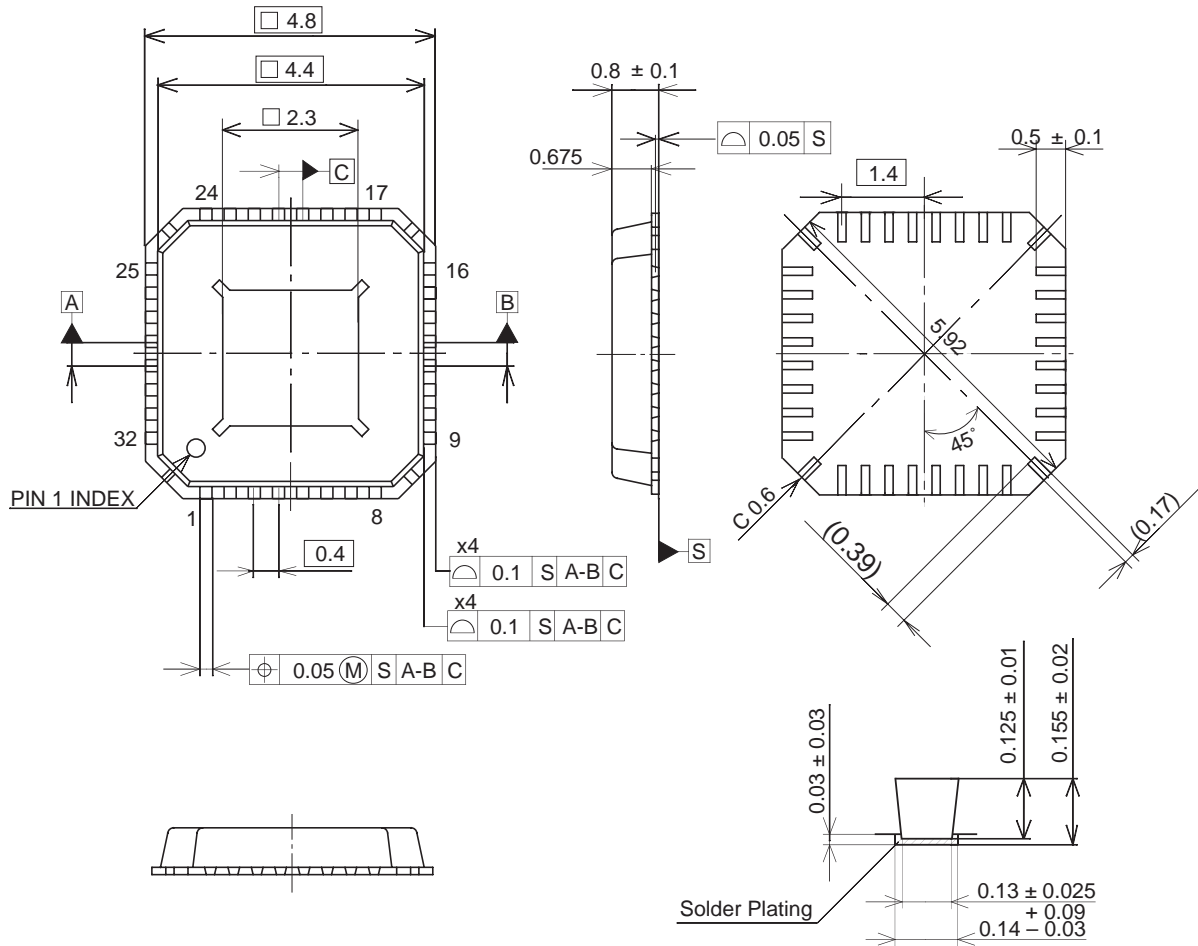

NOTE:1)The dimensions of the terminal section apply to the ranges of 0.1mm and 0.25mm from the end of a terminal.

TERMINAL SECTION

PACKAGE STRUCTURE

SONY CODE	VQFN-32P-07
EIAJ CODE	_____
JEDEC CODE	_____

PACKAGE MATERIAL	EPOXY RESIN
LEAD TREATMENT	SOLDER PLATING
LEAD MATERIAL	COPPER ALLOY
PACKAGE MASS	0.04g



LittleDiode supplies new, hard to find or obsolete electronic components and semiconductors all over the world.

With over two million different components listed you are sure to find the part you need.

Feel free to visit us today at our online store:

[LittleDiode.com](http://LittleDiode.com)

Looking forward to providing you with the best possible service.