

PDIC for CD-R/RW

Description

The CXA2598M is a PDIC (photodetector IC) developed as a photodetector for the optical pickup of CD-R/RW. The photodiode and I-V amplifier operate at high speed (100MHz). When the strong light is emitted during write, the delay or ringing is not occurred because the limiter circuit is included in the I-V amplifier.

- Focus servo: astigmatic method
- Tracking servo: differential push-pull method

Features

- I-V amplifier (current-voltage conversion circuit)
- RF output of addition of A to D signals
- Wide band (100MHz typ.)
- Output limiter circuit
- Small transparent molded package (SOP)

Applications

Optical pickup for CD-R/RW

Structure

Bipolar silicon monolithic IC

Absolute Maximum Ratings (Ta = 25°C)

• Supply voltage	V _{CC}	5.5	V
• Operating temperature	T _{opr}	-10 to +70	°C
• Storage temperature	T _{stg}	-40 to +85	°C
• Allowable power dissipation	P _D	300	mW

Operating Condition

Supply voltage	V _{CC}	4.5 to 5.5	V
----------------	-----------------	------------	---

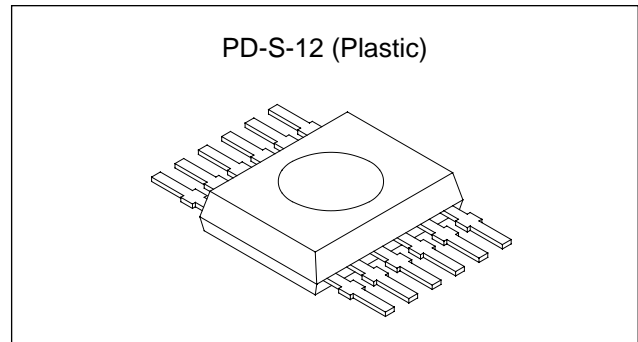

Sony reserves the right to change products and specifications without prior notice. This information does not convey any license by any implication or otherwise under any patents or other right. Application circuits shown, if any, are typical examples illustrating the operation of the devices. Sony cannot assume responsibility for any problems arising out of the use of these circuits.

Electrical and Optical Characteristics

(V_{CC} = 5.0V, V_C = 2.5V, T_a = 25°C)

Item	Symbol	Conditions	Min.	Typ.	Max.	Unit
Current consumption	I _{CC}	In the dark	—	16	25	mA
Output offset voltage (A to D)	V _{off}	In the dark, V _C reference	-30	0	30	mV
Output offset voltage (E to H)	V _{off}	In the dark, V _C reference	-25	0	25	mV
Output offset voltage (RF)	V _{off}	In the dark, V _C reference	-100	0	100	mV
Output offset voltage difference	ΔV _{off}	(A + B) - (C + D), in the dark	-20	0	20	mV
		(A + D) - (B + C), in the dark	-20	0	20	mV
		(A + C) - (B + D), in the dark	-20	0	20	mV
		(E + G) - (F + H), in the dark	-20	0	20	mV
Offset temperature drift (A to H)	ΔV _{off} /T	In the dark	-100	—	100	μV/°C
Offset temperature drift (RF)	ΔV _{off} /T	In the dark	-1.0	—	1.0	mV/°C
Output voltage (A to D)	V _O	λ = 780nm, P _O = 10μW	82	110	138	mV
Output voltage (E to H)	V _O	λ = 780nm, P _O = 10μW	338	450	563	mV
Output voltage (RF)	V _O	λ = 780nm, P _O = 10μW	165	220	275	mV
Maximum output voltage (A to H, RF)	V _O	λ = 780nm, P _O = 500μW	3.9	4.0	—	V
Frequency response 1 (A to D)	f _c	λ = 780nm P _O = 10μW _{BC} , 4μW _{p-p} 100kHz reference, -3dB	60	100	—	MHz
Frequency response 1 (E to H)	f _c	λ = 780nm P _O = 10μW _{BC} , 4μW _{p-p} 100kHz reference, -3dB	12	20	—	MHz
Frequency response 1 (RF)	f _c	λ = 780nm P _O = 10μW _{BC} , 4μW _{p-p} 100kHz reference, -3dB	60	100	—	MHz
Frequency response 2 (A to D)	ΔG	λ = 780nm P _O = 10μW _{BC} , 4μW _{p-p} 35MHz/100kHz	-0.5	0	0.5	dB
Frequency response 2 (RF)	ΔG	λ = 780nm P _O = 10μW _{BC} , 4μW _{p-p} 35MHz/100kHz	-1.0	0.5	1.0	dB
Group delay difference (A to D)	ΔG _d	100kHz to 35MHz	—	0.5	2	ns
Group delay difference (RF)	ΔG _d	100kHz to 35MHz	—	0.5	2	ns
Settling time 1 (A to D)	T _{set1}	Output 500mV → 5mV	—	—	40	ns
Settling time 1 (E to H)	T _{set1}	Output 500mV → 5mV	—	—	70	ns
Settling time 2 (A to D)	T _{set2}	Output 500mV → 0.5mV	—	—	70	ns
Slew rate (A to D)	SR	—	200	—	—	V/μs
Slew rate (E to H)	SR	—	40	—	—	V/μs

Note 1) Output offset voltage: V_C is the reference.

Note 2) Output voltage: V_C is the reference. However, the offset voltage is excluded.

Note 3) Output voltage, offset temperature drift, frequency response, group delay difference, settling time, slew rate: Confirmation of design.

Note 4) Measurement by the optical input: Measurement is made by emitting the light to the center of each photodiode.

Measurement Circuit

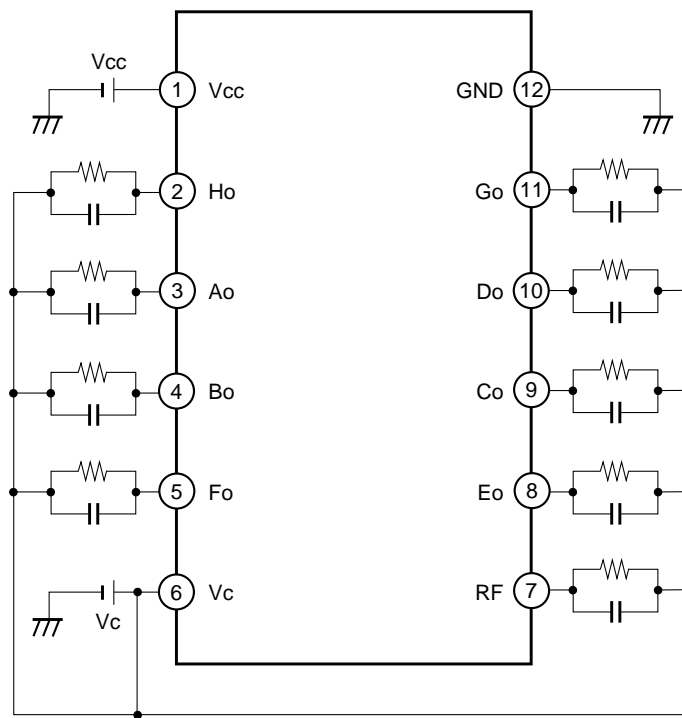

* All loads are 2.5kΩ/20pF.

Photodetector Position

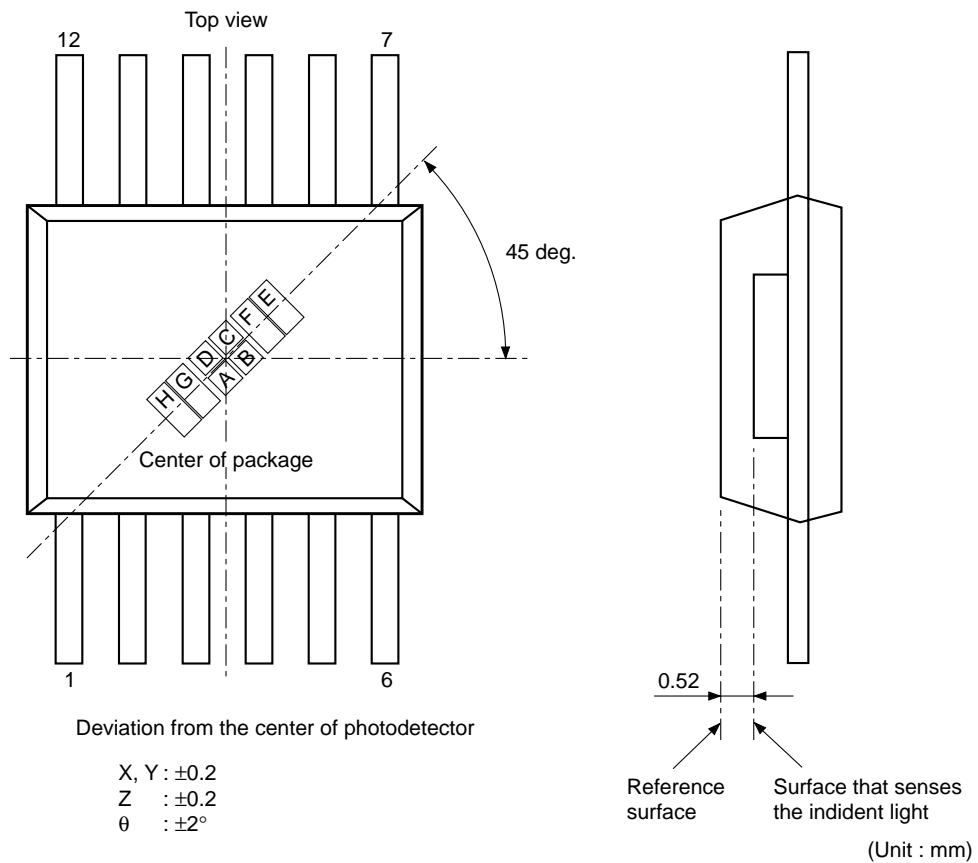

Photodetector Pattern Dimensions (Unit: μm)

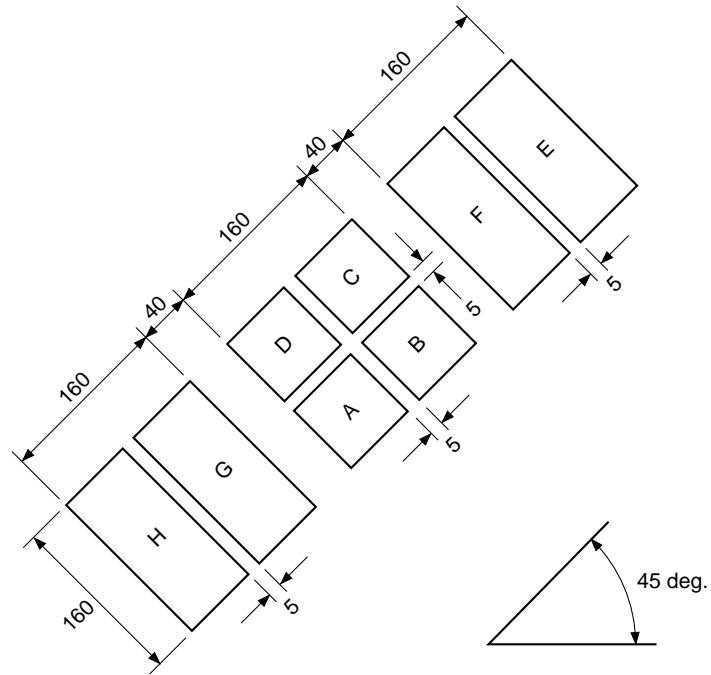

Circuit Block Diagram

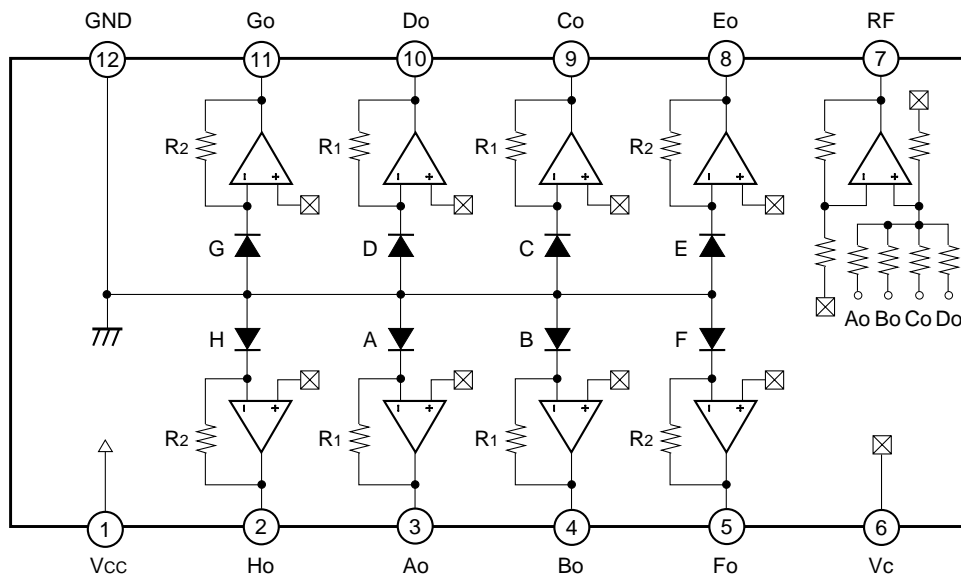

$R_1 = 29\text{k}\Omega$, $R_2 = 118\text{k}\Omega$
 A, B, C, D, E, F, G and H are the photodiodes. (Optical sensitivity: Approximately 0.40A/W)

Pin Description

Pin No.	Symbol	I/O	Equivalent circuit	Description
3 4 9 10	Ao Bo Co Do	O		Output of voltage signals converted from optical signals
2 5 8 11	Ho Fo Eo Go	O		Output of voltage signals converted from optical signals
7	RF	O		Output of addition of Ao to Do signals
12	GND			For dual power supply : negative power supply For a single power supply : GND
6	Vc	I		For dual power supply : GND For a single power supply : center voltage input
1	Vcc	I		Positive power supply

Example of Representative Characteristics

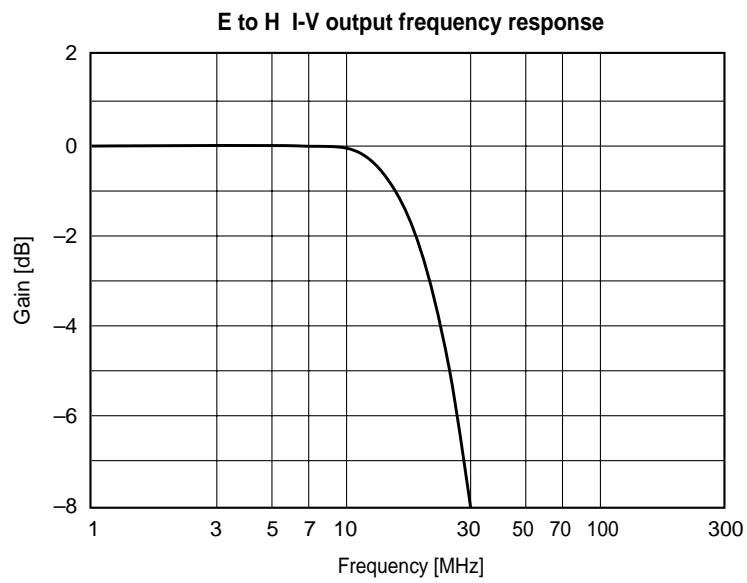
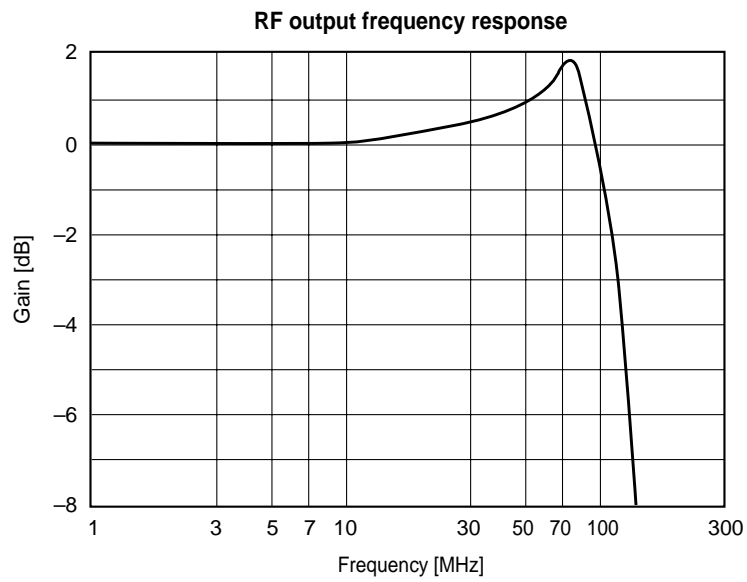
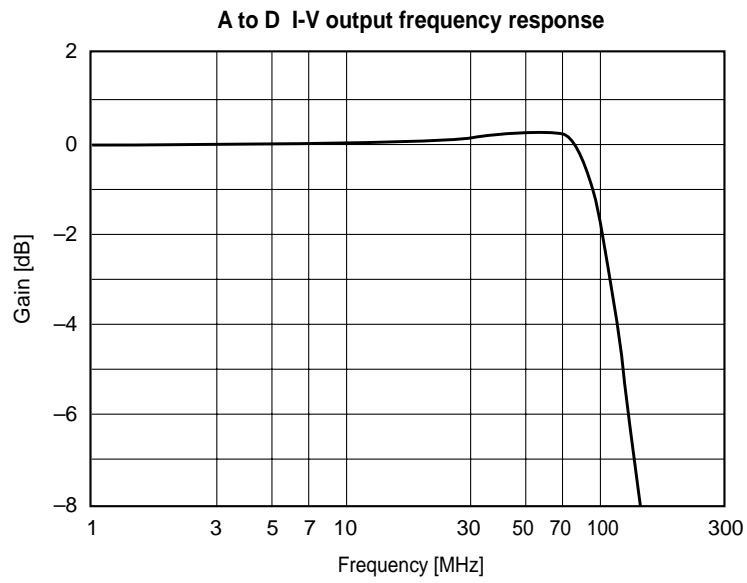

Notes on Operation

1. Connection to RF amplifier

The voltage input-type RF amplifier should be used because the CXA2598M is the voltage output type. The noise allowance is dramatically increased compared to the case where the conventional photodiode and the current input-type RF amplifier are used.

2. Power supply

The CXA2598M can be used with a single power supply or dual power supply. However, this IC is not provided with a center voltage generating circuit, and so when used with a single power supply the center voltage must be supplied from the RF amplifier or some other device.

	(Pin 1) V _{CC}	(Pin 12) GND	(Pin 6) V _c
Dual power supply	Positive power supply	Negative power supply	GND
Single power supply	Positive power supply	GND	Center voltage

The potential difference between the V_{CC} pin and the GND pin should be in the range of 4.5 to 5.5V in both of a single power supply and dual power supply.

3. Soldering

The reflow soldering is not guaranteed for the CXA2598M.

4. Mechanical strength for package

The mechanical strength for the package is not guaranteed for the CXA2598M. Do not employ the mounting method which gives much weight to the package.

5. Visual inspection standard

Another specifications and limit samples must be exchanged regarding visual inspection standards for the photodetector.

Package Outline

Unit: mm

PD-S-12

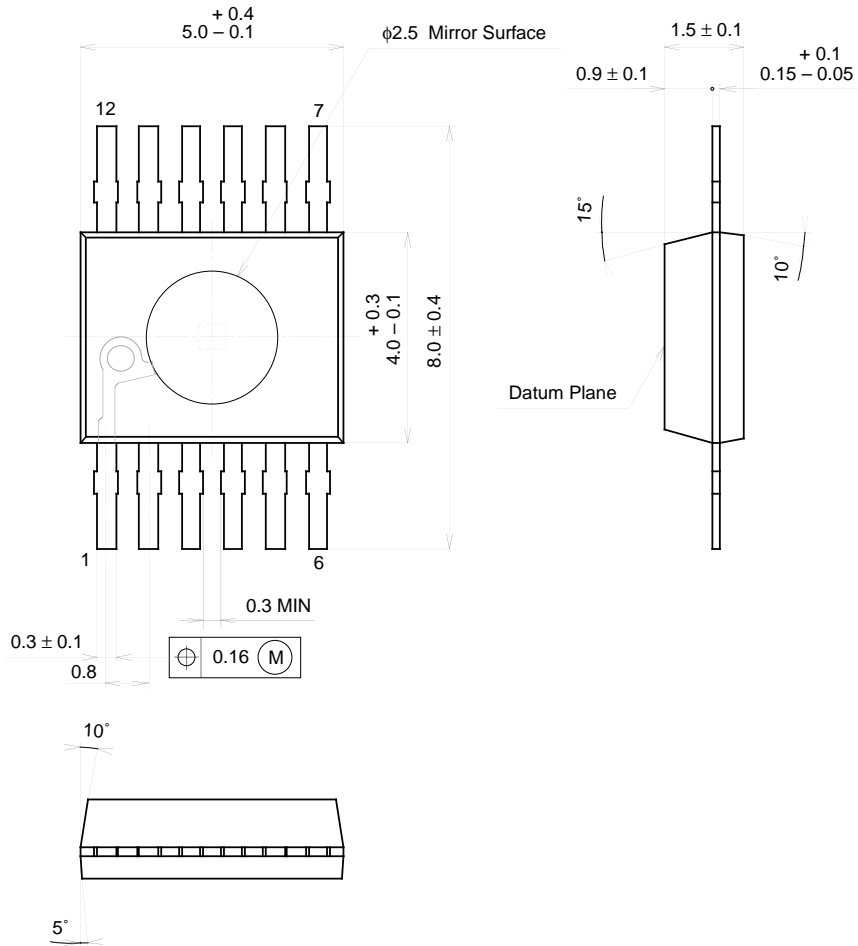

SONY CODE	PD-S-12
EIAJ CODE	_____
JEDEC CODE	_____

PACKAGE MASS	0.05g
--------------	-------



LittleDiode supplies new, hard to find or obsolete electronic components and semiconductors all over the world.

With over two million different components listed you are sure to find the part you need.

Feel free to visit us today at our online store:

LittleDiode.com

Looking forward to providing you with the best possible service.