

## Dolby\* B Type Noise Reduction System with Playback Equalizer Amplifier

### Description

The CXA2560Q is an IC designed for use in car stereo cassette decks. Functions include Dolby B type noise reduction (NR) system, playback equalizer amplifier and music sensor into a single chip.

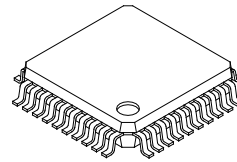
### Features

- Few external parts
- Small package (40-pin QFP)
- Same pin configuration as for the Dolby B-C type NR system (CXA2561Q) and no Dolby NR system (CXA2559Q)
- Dolby B type NR and playback equalizer amplifier into a single chip
- FORWARD/REVERSE head select switch
- Mute function
- Music signal interval detection level can be set by the external resistors/capacitors (2 modes).
- High-frequency cut-off of the music sensor circuit can be adjusted by the external capacitance.

### Applications

- Car stereo cassette decks
- Playback-only cassette decks

40 pin QFP (Plastic)



### Structure

Bipolar silicon monolithic IC

### Absolute Maximum Ratings

• Supply voltage	V <sub>CC</sub>	12	V
• Operating temperature	T <sub>opr</sub>	-40 to +85	°C
• Storage temperature	T <sub>stg</sub>	-65 to +150	°C
• Power dissipation	P <sub>D</sub>	430	mW

### Operating Condition

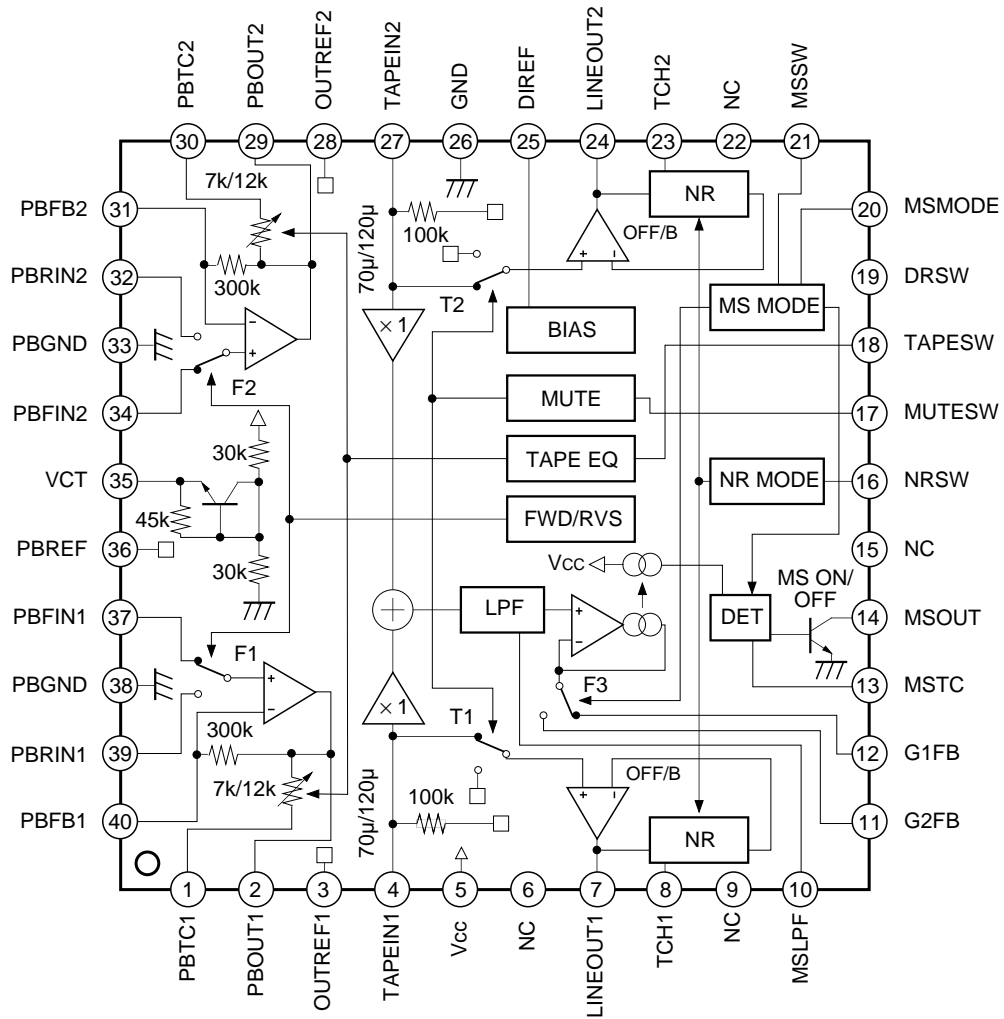
Supply voltage	V <sub>CC</sub>	6.5 to 11	V
----------------	-----------------	-----------	---

\* This IC is available only to the licensees of Dolby Laboratories Licensing Corporation from whom licensing and applications information may be obtained.

\* "Dolby" and the double D symbols are trademarks of Dolby Laboratories Licensing Corporation.

Sony reserves the right to change products and specifications without prior notice. This information does not convey any license by any implication or otherwise under any patents or other right. Application circuits shown, if any, are typical examples illustrating the operation of the devices. Sony cannot assume responsibility for any problems arising out of the use of these circuits.

Block Diagram and Pin Configuration



Pin Description

(Ta = 25°C, Vcc = 8.0V, DVcc = 5.0V)

Pin No.	Symbol	Typical pin voltage		I/O	I/O resistance	Equivalent circuit	Description
		DC	AC				
1 30	PBTC1 PBTC2	4.0V	—	—	—		Playback equalizer amplifier capacitance.
2 29	PBOUT1 PBOUT2	4.0V	-25dBm	O	—		Playback equalizer amplifier output.
3 28	OUTREF1 OUTREF2	4.0V	—	O	—		Output reference. (Vcc/2 output)
4 27	TAPEIN1 TAPEIN2	4.0V	-30dBm	I	100kΩ		TAPE input.
5	Vcc	8.0V	—	—	—		Power supply.

(Ta = 25°C, Vcc = 8.0V, DVcc = 5.0V)

Pin No.	Symbol	Typical pin voltage		I/O	I/O resistance	Equivalent circuit	Description
		DC	AC				
7 24	LINEOUT1 LINEOUT2	4.0V	-6dBm	O	—		Line output.
8 23	TCH1 TCH2	0.3V	—	—	—		Time constant for the HLS.
10	MSLPF	4.0V	—	—	100k		Cut-off frequency adjustment of the music sensor LPF.
11 12	G2FB G1FB	4.0V	—	—	—		Music signal interval detection level setting.

(Ta = 25°C, Vcc = 8.0V, DVcc = 5.0V)

Pin No.	Symbol	Typical pin voltage		I/O	I/O resistance	Equivalent circuit	Description
		DC	AC				
13	MSTC	—	—	—	—		Time constant for detecting the music signal interval.
14	MSOUT	0.2V when a signal is detected ; DVcc when no signal is detected	—	O	—		Music sensor output.
17	MUTESW	0.0V when open	—	I	100kΩ		Mute function control. Low (open) : Mute OFF High: Mute ON
18	TAPESW						Playback equalizer amplifier control. Low (open) : 70μs High: 120μs
21	MSSW						Music sensor control. Low (open) : MS ON High : MS OFF
16	NRSW	0.0V when open	—	I	100kΩ		Dolby NR control. Low (open) : NR OFF High: NR ON
19	DRSW						Head select control. Low (open) : FORWARD High: REVERSE

(Ta = 25°C, Vcc = 8.0V, DVcc = 5.0V)

Pin No.	Symbol	Typical pin voltage		I/O	I/O resistance	Equivalent circuit	Description
		DC	AC				
20	MSMODE	0.0V when open	—	I	100kΩ		Music sensor mode control. Low (open): G1 High: G2
25	DIREF	1.2V	—	—	—		Resistance for setting the reference current. (Connects 18kΩ between DIREF pin and GND for the standard setting.)
26	GND	0.0V	—	—	—		Ground.
31 40	PBFB2 PBFB1	4.0V	-70dBm	I	—		Playback equalizer amplifier feedback.
32 39	PBRIN2 PBRIN1	4.0V	-70dBm	I	—		Playback equalizer amplifier input. (REVERSE head connected)
34 37	PBFIN2 PBFIN1						Playback equalizer amplifier input. (FORWARD head connected)
33 38	PBGND	0.0V	—	—	—	Playback equalizer amplifier ground. (Connect to ground.)	

(Ta = 25°C, Vcc = 8.0V, DVcc = 5.0V)

Pin No.	Symbol	Typical pin voltage		I/O	I/O resistance	Equivalent circuit	Description
		DC	AC				
35	VCT	4.0V	—	O	—		Center. (Vcc/2 output)
36	PBREF	4.0V	—	O	—		Playback equalizer amplifier reference. (Vcc/2 output)
6 9 15 22	NC	—	—	—	—		Not connected.

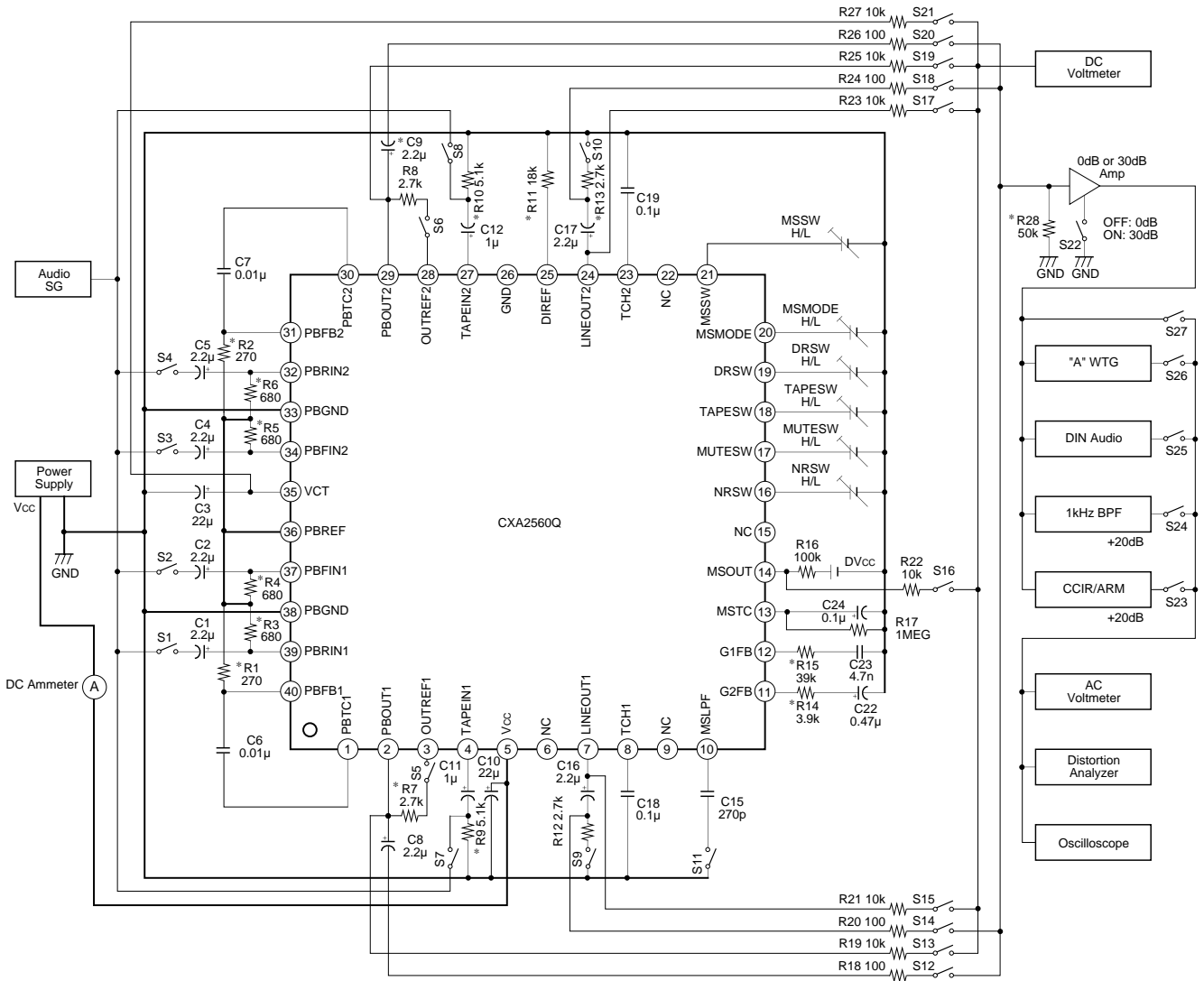
**Electrical Characteristics**

(Ta = 25°C, Vcc = 8.0V. DVcc = 5.0V)

Item	Symbol	Measurement conditions	Min.	Typ.	Max.	Unit
Operating voltage	Vopr		6.5	8.0	11.0	V
Current consumption	Icc	No signal, NR OFF, MUTE OFF, 70μs, MS ON	7.6	11.6	15.6	mA
Dolby NR (0dB = Dolby level LINEOUT of -6dBm)						
TAPEIN input sensitivity	VTIN	TAPEIN 1kHz, LINEOUT 0dB, NR OFF	-32.0	-30.0	-28.0	dBm
B type decode boost characteristics 1	BP1	TAPEIN 500Hz, LINEOUT -25dB, NR B	1.4	2.9	4.4	dB
B type decode boost characteristics 2	BP2	TAPEIN 2kHz, LINEOUT -25dB, NR B	5.5	7.0	8.5	dB
B type decode boost characteristics 3	BP3	TAPEIN 5kHz, LINEOUT -25dB, NR B	3.9	5.4	6.9	dB
B type decode boost characteristics 4	BP4	TAPEIN 10kHz, LINEOUT -40dB, NR B	9.7	10.4	11.9	dB
B type decode boost characteristics 5	BP5	TAPEIN 10kHz, LINEOUT 0dB, NR B	-1.1	0.4	1.9	dB
Total harmonic distortion 1	THD1	TAPEIN 1kHz -20dBm, NR OFF, RL = 2.7kΩ	—	0.01	0.2	%
Total harmonic distortion 2	THD2	TAPEIN 1kHz -20dBm, NR B, RL = 2.7kΩ	—	0.04	0.2	%
Decode S/N ratio 1	SN1	No signal, NR B, Rg = 5.1kΩ, CCIR/ARM filter used	77.0	87.0	—	dB
Signal handling	SH1	TAPEIN 1kHz, NR OFF, RL = 2.7kΩ, THD = 1%	13.0	14.4	—	dB
Crosstalk between channels 1	CT1	TAPEIN 1kHz -24dBm, NR OFF, 1kHz BPF used	—	-96.0	-70.0	dB
Mute characteristic	MUTE	TAPE IN 1kHz -24dBm, MUTE ON, NR OFF, 1kHz BPF used	—	-110.0	-70.0	dB
Output DC offset voltage	Vos1	No signal, NR OFF, difference from VCT	-0.1	0.0	0.1	V
Playback Equalizer Amplifier						
Playback equalizer amplifier reference output level	PBREF	PBIN 315Hz -70dBm, 120μs mode	-27.0	-25.0	-23.0	dBm
Playback equalizer amplifier frequency response 1	F120	PBIN 2.7kHz -58.5dBm, 120μs mode at 315Hz	-1.5	0.0	1.5	dB
Playback equalizer amplifier frequency response 2	F70	PBIN 4.5kHz -53.8dBm, 70μs mode at 315Hz	-1.5	0.0	1.5	dB
Signal handling	SH2	PBIN 1kHz, 120μs mode, RL = 2.7kΩ, THD = 1%	-10.0	-3.0	—	dBm
Total harmonic distortion	THD4	PBIN 1kHz -52dBm, 120μs mode, RL = 2.7kΩ	—	0.07	0.5	%
S/N ratio	SN3	No signal, 70μs mode, Rg = 680Ω, CCIR/ARM filter used	57.0	63.5	—	dB
Output DC offset voltage	Vos2	No signal, 120μs mode, Rg = 680Ω, difference from VCT	-1.0	0.0	1.0	V

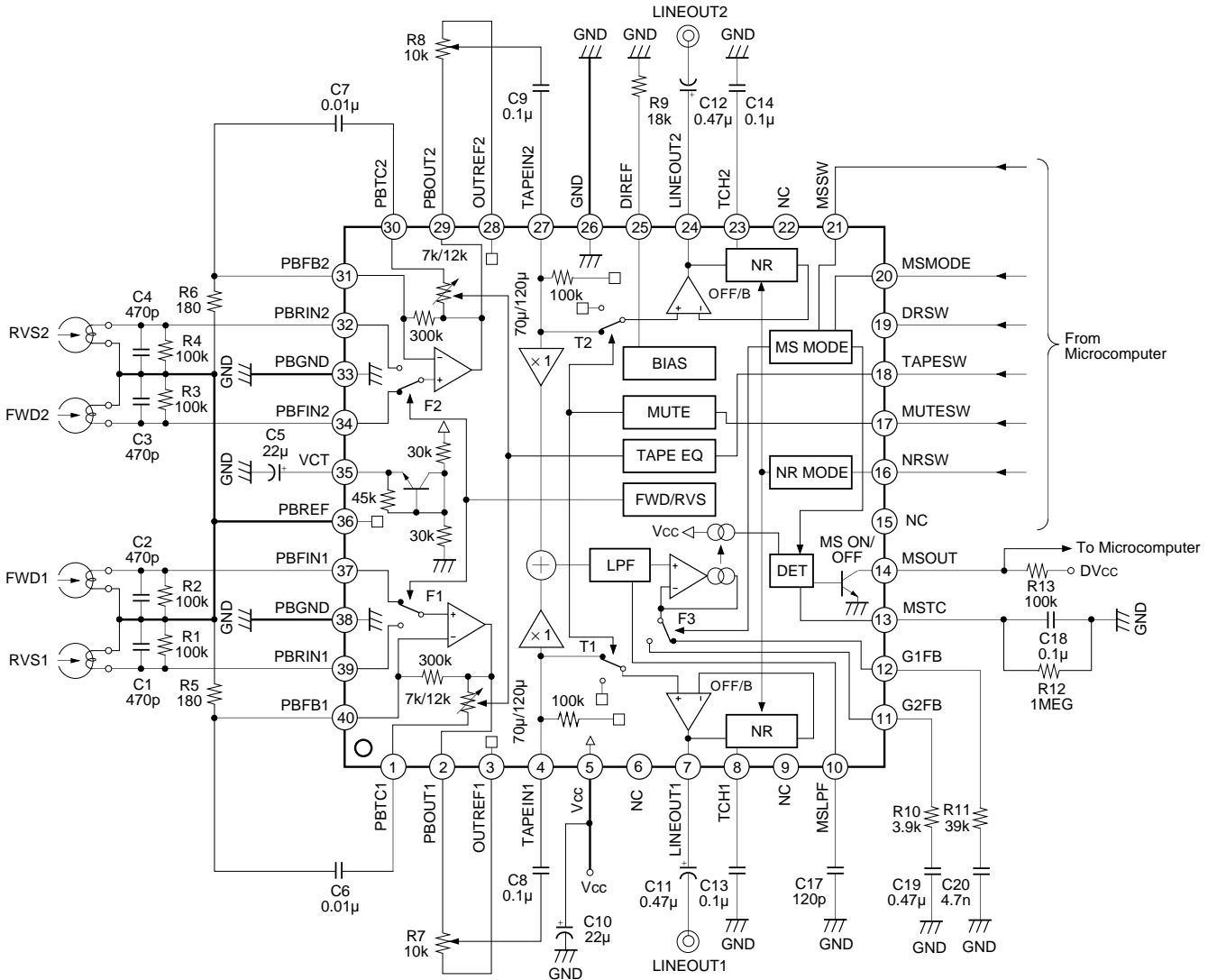
Item	Symbol	Measurement conditions	Min.	Typ.	Max.	Unit
Crosstalk between channels	CT4	PBIN 1kHz -52dBm, 120 $\mu$ s mode, 1kHz BPF used	—	-75.0	-70.0	dB
Crosstalk between FORWARD and REVERSE	CT5	PBIN 1kHz -52dBm, 120 $\mu$ s mode, 1kHz BPF used	—	-80.0	-70.0	dB
Music Sensor						
Signal detection level 1	V <sub>MS1</sub>	TAPEIN 5kHz, MS ON, G1 mode, external constant of 39k $\Omega$ and 0.0047 $\mu$ F	-43.0	-40.0	-37.0	dBm
Signal detection level 2	V <sub>MS2</sub>	TAPEIN 5kHz, MS ON, G2 mode, external constant of 3.9k $\Omega$ and 0.47 $\mu$ F	-63.0	-60.0	-57.0	dBm
MS output leak current	I <sub>OH</sub>	No signal, MS OFF, G1 mode	—	0.0	1.0	$\mu$ A
MS output saturation voltage	V <sub>OL</sub>	TAPEIN 5kHz -30dBm, MS ON, G1 mode, 1mA applied to MSOUT pin	—	0.3	1.0	V
Logic Voltage						
Low level	V <sub>IL</sub>	Input voltage of NRSW, MUTESW, TAPESW, DRSW, MSMODE, MSSW	0.0	—	0.8	V
High level	V <sub>IH</sub>	Input voltage of NRSW, MUTESW, TAPESW, DRSW, MSMODE, MSSW	2.5	—	V <sub>CC</sub>	V

Electrical Characteristics Measurement Circuit



- Notes 1. Resistor tolerance      ±5%  
 \*: ±1%  
 2. Capacitor tolerance        ±5%  
 \*: ±2%  
 Coupling Capacitor          ±10%

Application Circuit

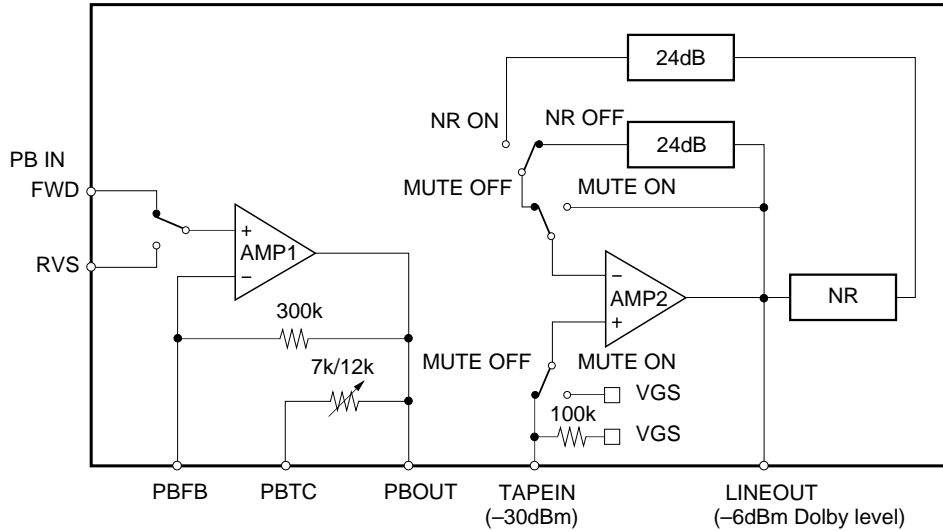


Application circuits shown are typical examples illustrating the operation of the devices. Sony cannot assume responsibility for any problems arising out of the use of these circuits or for any infringement of third party patent and other right due to same.

**Description of Operation**

**1. Signal route**

The CXA2560Q signal circuit is shown in Fig. 1.



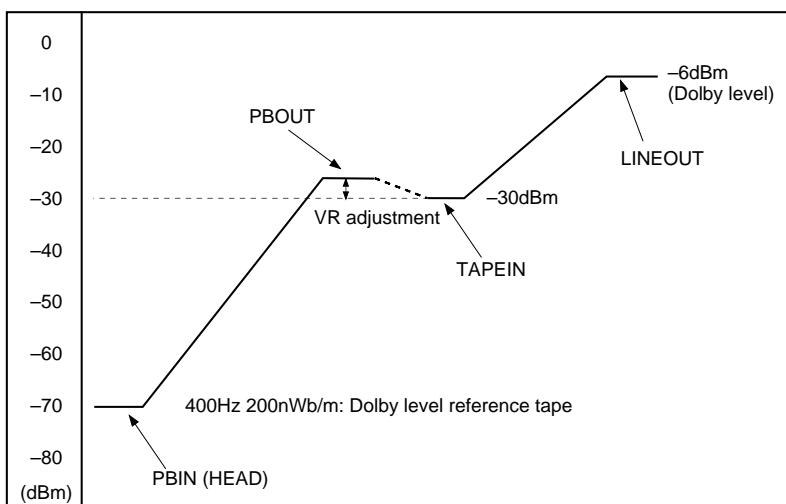
**Fig. 1. Signal route block diagram**

**2. Gain adjustment method**

Adjust the playback equalizer amplifier gain so that -6dBm (Dolby level) is output on LINEOUT (Pins 7 and 24) by playing back the reference tape for Dolby level adjustment.

Adjustment should be performed according to the rules of Dolby Laboratories Corporation because this IC has the built-in Dolby NR system.

Dolby level is defined as 200nWb/m measured according to the ANSI high efficiency head method.



**Fig. 2. Level diagram**

Use the following reference tapes specified by Dolby Laboratories Corporation.

1. A-bex Laboratories, Inc.  
(part no. TCC-130)
2. BASF (product code 09797 XE)
3. Kaneon Corp.  
(LC Engineering part no. LCT-7001)
4. Standard Tape Laboratory  
(catalogue no. 28)
5. TEAC Corporation, Japan  
(part no. MTT150)
6. TEAC Corporation of America  
(part no. MTT150)
7. Victor Company of Japan, Ltd.  
(part no. TMT-6130, VTT-727)
8. Sony Corporation (part no. TY-256)

3. Playback equalizer amplifier

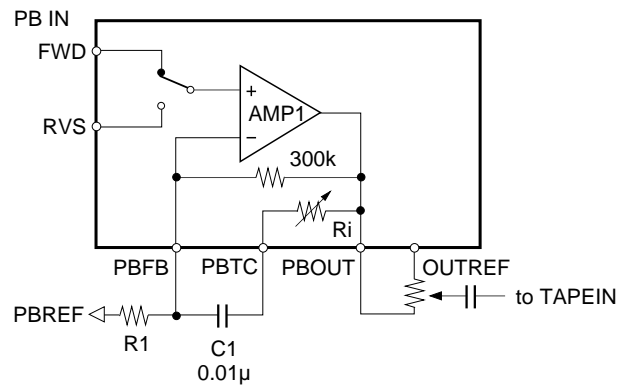


Fig. 3. Playback equalizer amplifier block diagram

The CXA2560Q configures the playback equalizer amplifier by connecting the external capacitor C1 and resistor R1 shown in Fig. 3.

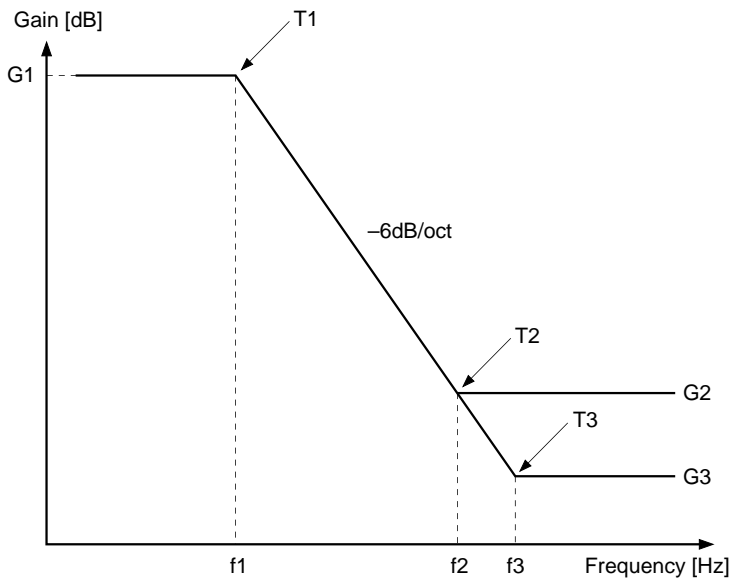
Two systems (FORWARD and REVERSE) of playback head input are provided for each channel.

The FORWARD input pin is selected when DRSW (Pin 19) is Low; REVERSE is selected when DRSW is High.

The playback equalizer amplifier frequency response can be set in two levels (70µs/120µs).

When TAPESW (Pin 18) is Low, Ri is 7kΩ; when TAPESW is High, Ri is 12kΩ.

The gain can be adjusted by connecting VR between PBOUT (Pins 2 and 9) and OUTREF (Pin 3 and 28); or by using VR for the external R1.



$$G1 = 20 \log \frac{R1 + 300k}{R1}$$

$$G2, G3 = 20 \log \frac{R1 + Ri // 300k}{R1}$$

$$T1 = C1 \cdot (300k + Ri)$$

$$T2, T3 = \frac{C1 \cdot (R1 \cdot 300k + 300k \cdot Ri + Ri \cdot R1)}{R1 + R2}$$

Fig. 4. Playback equalizer amplifier frequency response

4. Music sensor

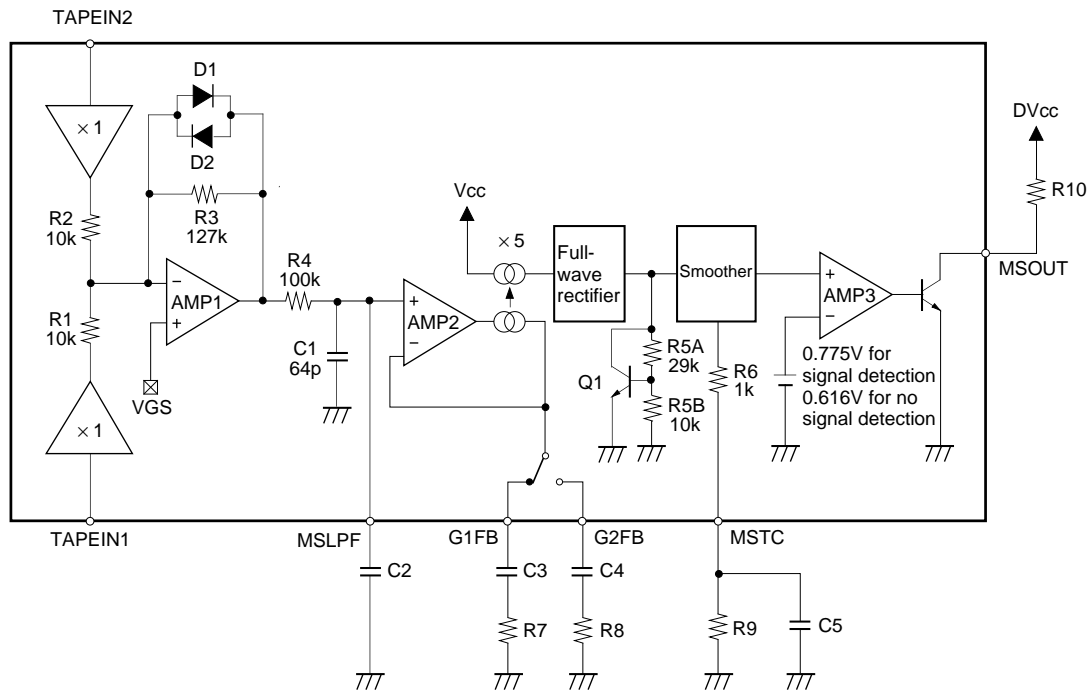


Fig. 5. Music sensor block diagram

(1) Adjustment of music signal detection level

Adjust the external resistors R7 and R8 to adjust the music signal interval detection level.

The signal detection level  $v_1$  and no signal detection level  $v_2$  are expressed by the following equations.

$$v_1 = -39 + 20 \log (39k/R_{ext}) \text{ [dBm]} \quad R_{ext}: R_7 \text{ or } R_8$$

$$v_2 = v_1 - 2 \text{ [dBm]}$$

(2) Low-frequency cut-off adjustment of music sensor

Adjust the external resistors R7, R8 and the external capacitors C3, C4 to adjust the low-frequency cut-off.

The low-frequency cut-off is expressed by the following equation.

$$f_{c1} = 1 / (2\pi \cdot C_{ext} \cdot R_{ext}) \quad C_{ext}, R_{ext}: C_3, R_7 \text{ or } C_4, R_8$$

(3) High-frequency cut-off adjustment of music sensor

Adjust the external capacitor C2 to MSLPF (Pin 10) to adjust the high-frequency cut-off. The high-frequency cut-off is expressed by the following equation.

$$f_{c2} = 1 / (2\pi \cdot (64p + C_2) \cdot 100k)$$

The high-frequency cut-off is approximately 25kHz when MSLPF is left open .

(4) Response time adjustment

Adjust the external resistor R9 and the external capacitor C5 to adjust the response time.

The response time for signal detection depends on the internal resistor R6 and the external capacitor C5.

The response time for no signal detection depends on the external resistor R9 and the external capacitor C5.

## 5. Operating mode control method

The CXA2560Q has a Dolby NR switch (NRSW), mute switch (MUTESW), playback equalizer amplifier select switch (TAPESW), head input select switch (DRSW), music sensor mode select switch (MSMODE) and music sensor switch (MSSW).

The operating modes for each switch are shown in the following table.

Pin No.	Pin name	Pin voltage	
		Low (OPEN)	High
16	NRSW	Dolby NR OFF	Dolby NR ON
17	MUTESW	MUTE OFF	MUTE ON
18	TAPESW	70 $\mu$ s	120 $\mu$ s
19	DRSW	PBIN FORWARD	PBIN REVERSE
20	MSMODE	G1	G2
21	MSSW	MS ON	MS OFF

### Notes on Operation

#### 1. DIREF pin resistance

The current on DIREF (Pin 25) is the reference for the Dolby NR static characteristic, playback equalizer amplifier resistor 7k $\Omega$ /12k $\Omega$  and the comparator threshold value of the music sensor.

Use the resistor with high accuracy for connecting to the DIREF pin.

(The resistance accuracy of 2% <metal-oxide> is recommended.)

#### 2. Dolby NR

The Dolby NR attack/recovery time is determined by the capacitance connected to TCH (Pins 8 and 23).

Use the parts, connected to these pins, with high accuracy and small temperature characteristics.

(The capacitance accuracy of 10% <film> is recommended.)

#### 3. Playback equalizer amplifier

The playback equalizer amplifier characteristics are determined by the resistor connected between the IC internal resistor and PBFB (Pins 31 and 40) and the capacitor connected between PBFB and PBTC (Pins 1 and 30). Use the parts which satisfies the accuracy required for the playback equalizer amplifier.

#### 4. Music sensor

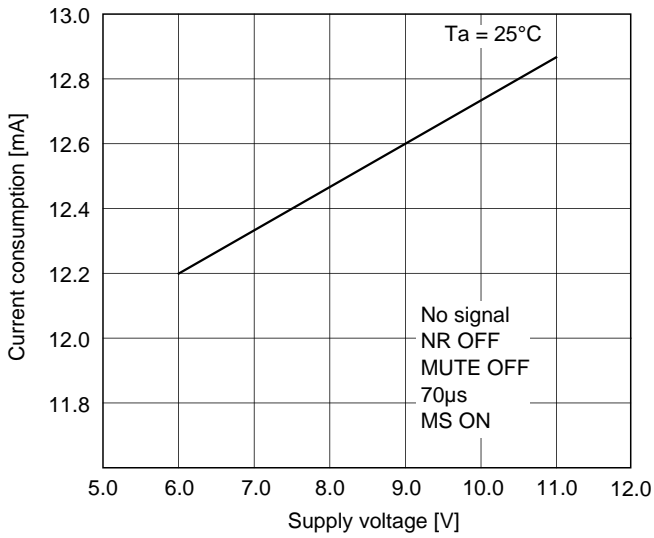
The resistance and capacitance connected to G2FB (Pin 11) and G1FB (Pin 12) determine the detection level and high-frequency cut-off.

The response time is determined by the resistance and capacitance connected to MSTC (Pin 13).

Use the parts which satisfies the accuracy required for the music sensor.

Example of Representative Characteristics

Supply voltage vs. Current consumption



Playback equalizer amplifier frequency response

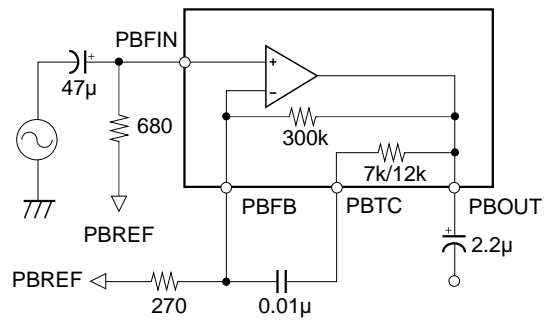
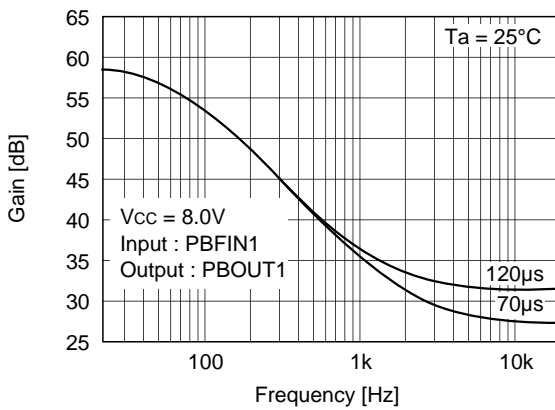
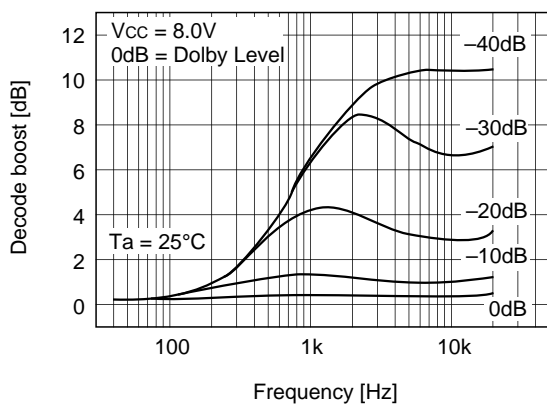
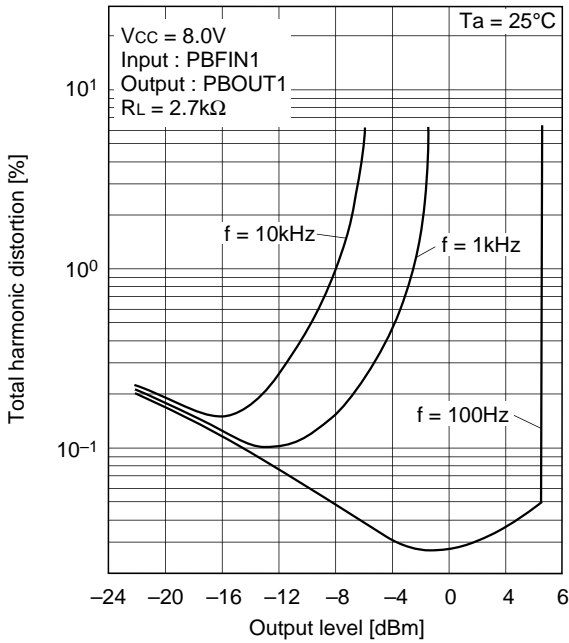


Fig. 6 Measurement circuit for playback equalizer amplifier frequency response

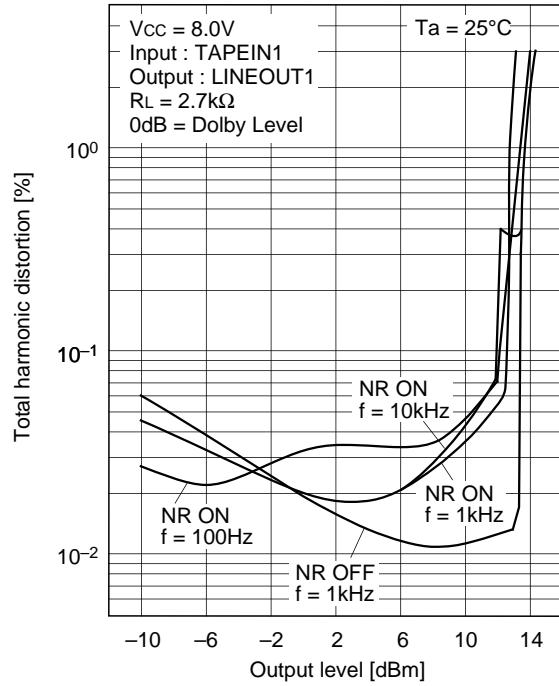
B type decode boost characteristics



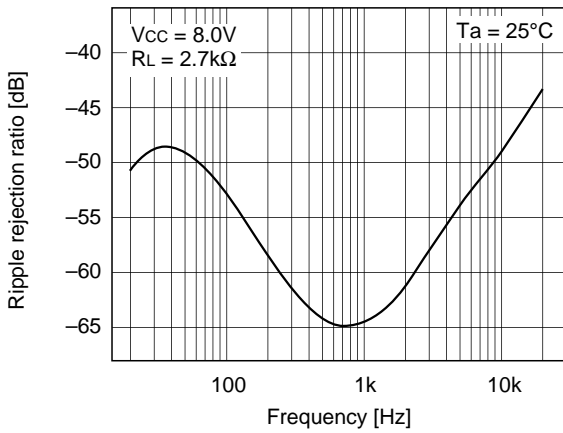
**Total harmonic distortion (playback equalizer amplifier)**



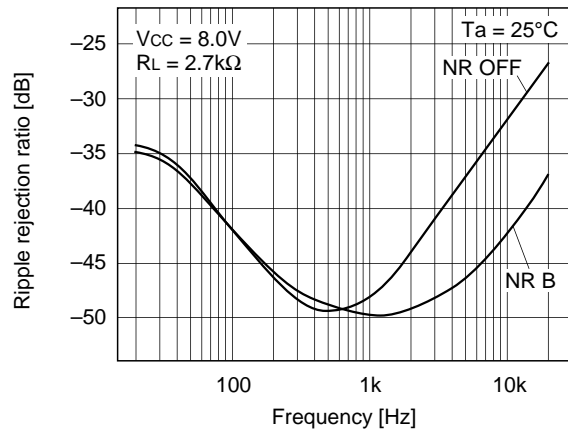
**B type total harmonic distortion (NR OFF included)**



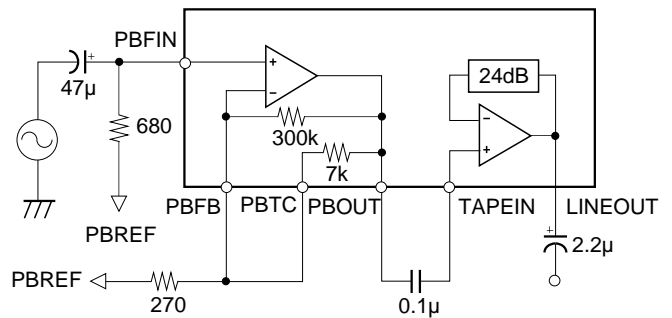
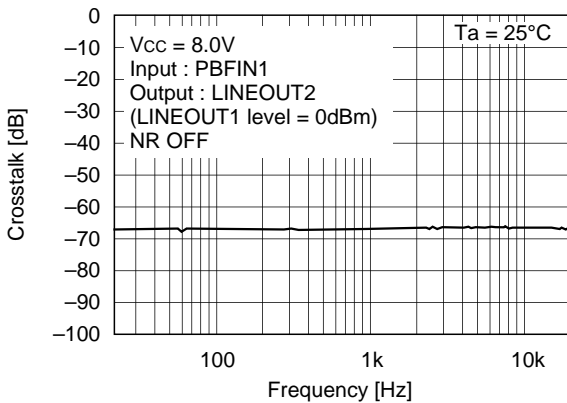
**Ripple rejection ratio (PBOUT)**



**Ripple rejection ratio (LINEOUT)**

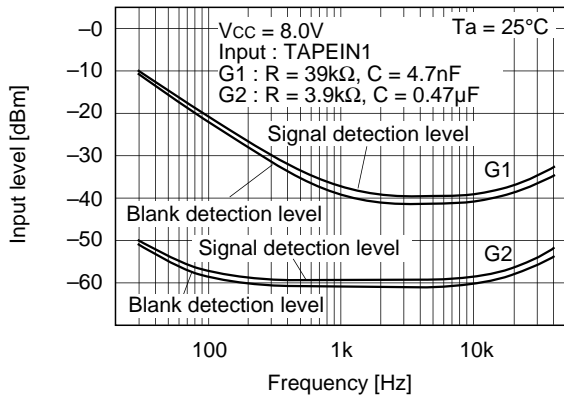


**Crosstalk between channels (1ch → 2ch)**

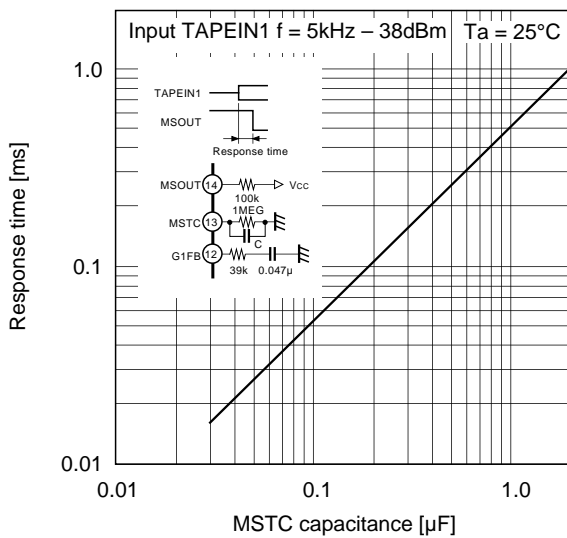


**Fig. 7 Measurement circuit for crosstalk between channels**

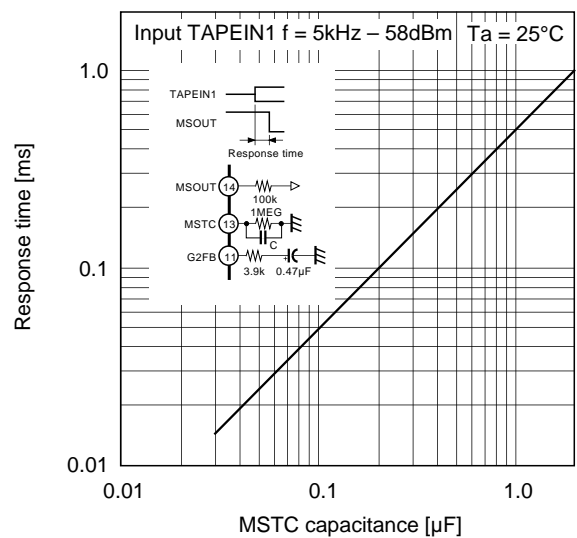
Frequency response for signal and blank detection level



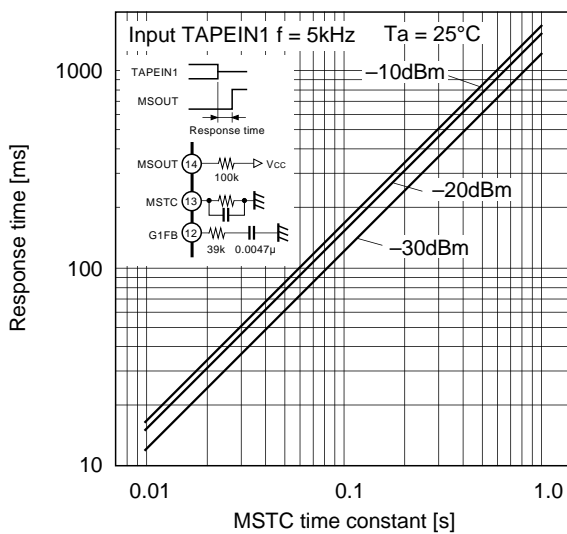
Signal detection response time (G1)



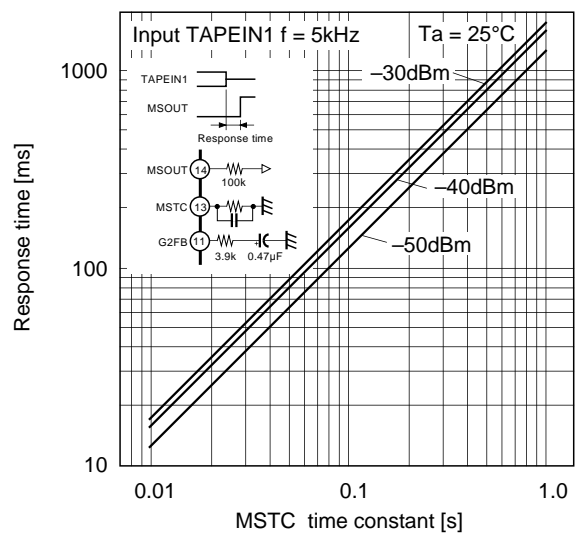
Signal detection response time (G2)



Blank detection response time (G1)

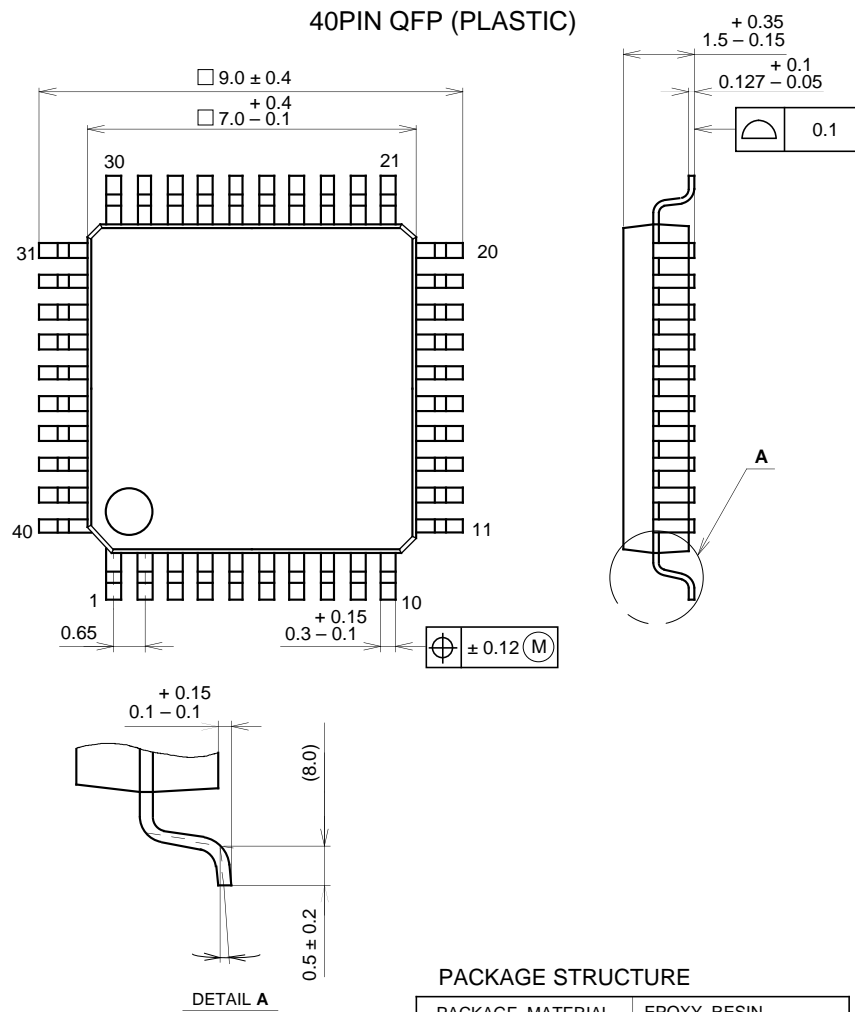


Signal detection response time (G2)



Package Outline

Unit: mm



SONY CODE	QFP-40P-L01
EIAJ CODE	*QFP040-P-0707
JEDEC CODE	_____

**PACKAGE STRUCTURE**

PACKAGE MATERIAL	EPOXY RESIN
LEAD TREATMENT	SOLDER / PALLADIUM PLATING
LEAD MATERIAL	COPPER / 42 ALLOY
PACKAGE WEIGHT	0.2g

**NOTE : PALLADIUM PLATING**  
 This product uses S-PdPPF (Sony Spec.-Palladium Pre-Plated Lead Frame).

This datasheet has been downloaded from:

[www.DatasheetCatalog.com](http://www.DatasheetCatalog.com)

Datasheets for electronic components.



LittleDiode supplies new, hard to find or obsolete electronic components and semiconductors all over the world.

With over two million different components listed you are sure to find the part you need.

Feel free to visit us today at our online store:

[LittleDiode.com](http://LittleDiode.com)

Looking forward to providing you with the best possible service.