

RF Amplifier for CD Player/CD-ROM

Description

The CXA2556Q is an IC for RF signal processing of CD player and CD-ROM.

Features

- Wide-band RF AC amplifier
(RF AC signal $f_c \geq 20\text{MHz}$)
- 4-mode RF equalizer (active filter type)
- RF equalizer boost amount and cut-off frequency adjustable
- EFM time constant adjustable (switching function provided)
- Peak hold time constant of mirror circuit adjustable
- Tracking error amplifier cut-off frequency adjustable
- Tracking error amplifier voltage gain adjustable
- APC (Automatic Power Control) function
- APC ON/OFF control

Absolute Maximum Ratings

• Supply voltage	V_{CC}	7	V
• Storage temperature	T_{stg}	-65 to +150	°C
• Power consumption	P_D	800	mW

Operating Conditions

• Supply voltage	$V_{CC} - GND$	3.0 to 5.5	V
• Operating temperature	T_{opr}	-20 to +75	°C

32 pin QFP (Plastic)

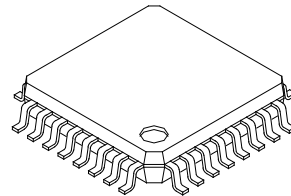

Applications

- CD players
- CD-ROM drives

Functions

- RF summing amplifier
- RF equalizer
- Focus error amplifier
- Tracking error amplifier
- Mirror detection function
- APC circuit

Sony reserves the right to change products and specifications without prior notice. This information does not convey any license by any implication or otherwise under any patents or other right. Application circuits shown, if any, are typical examples illustrating the operation of the devices. Sony cannot assume responsibility for any problems arising out of the use of these circuits.

Block Diagram

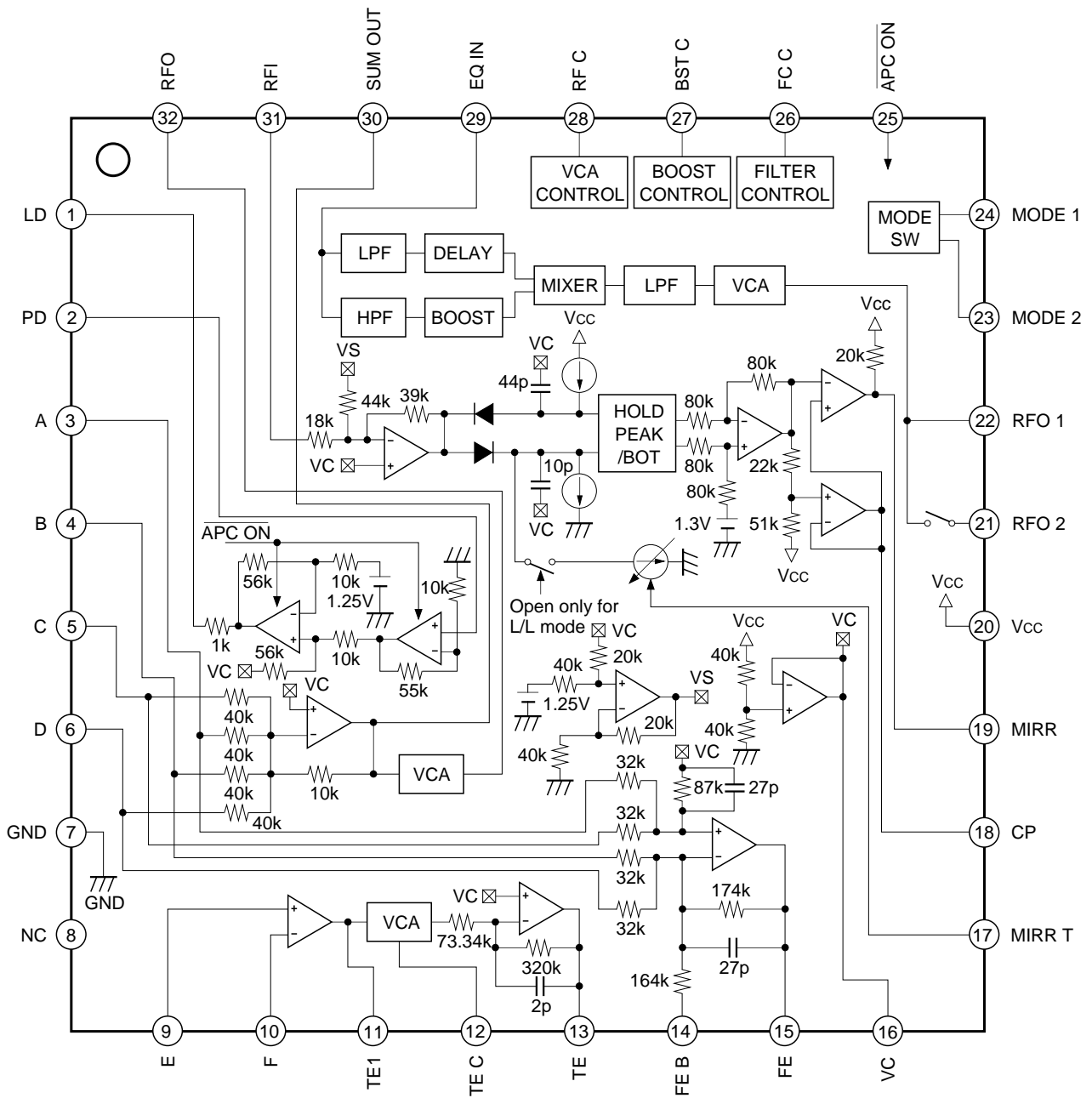

Pin Description

Pin No.	Symbol	I/O	Equivalent circuit	Description
1	LD	O		APC amplifier output.
2	PD	I		APC amplifier input.
3 4 5 6	A B C D	I I I I		Input of RF summing amplifier and focus error amplifier.
7	GND			Ground.
9 10 11 12 13	E F TE1 TE C TE	I O O O O		Tracking error amplifier input for Pins 9 and 10; tracking error amplifier output for Pin 11; tracking error amplifier low-frequency gain setting for Pin 12; tracking error amplifier output for Pin 13.

Pin No.	Symbol	I/O	Equivalent circuit	Description
8	NC			Not connected.
14 15	FE B FE	O O		Focus bias adjustment for Pin 14; focus error amplifier output for Pin 15.
16	VC	O		$(V_{cc} + GND)/2$ DC voltage output.
17	MIRR T	I		Peak hold time constant adjustment.
18	CP	I		Connects a mirror hold capacitor. Non-inverted input of mirror comparator.
19	MIRR	O		Mirror comparator output.

Pin No.	Symbol	I/O	Equivalent circuit	Description															
20	Vcc			Power supply.															
21 22	RFO 2 RFO 1	O O		Buffer switch output for the RF time constant setting for Pin 21. ON when Pins 23 and 24 are connected to GND. RF equalizer output.															
23	MODE 2	I		Double-speed mode switching input. <table border="1" style="margin-top: 10px;"> <thead> <tr> <th></th> <th>Mode 1</th> <th>Mode 2</th> </tr> </thead> <tbody> <tr> <td>× 1</td> <td>GND</td> <td>GND</td> </tr> <tr> <td>× N</td> <td>Vcc</td> <td>GND</td> </tr> <tr> <td>× 1.5N</td> <td>GND</td> <td>Vcc</td> </tr> <tr> <td>× 2.0N</td> <td>Vcc</td> <td>Vcc</td> </tr> </tbody> </table>		Mode 1	Mode 2	× 1	GND	GND	× N	Vcc	GND	× 1.5N	GND	Vcc	× 2.0N	Vcc	Vcc
	Mode 1	Mode 2																	
× 1	GND	GND																	
× N	Vcc	GND																	
× 1.5N	GND	Vcc																	
× 2.0N	Vcc	Vcc																	
24	MODE 1	I																	
25	APC ON	I		Switching pin for APC amplifier ON/OFF. OFF when connected to Vcc; ON when connected to GND.															
26	FC C	I		Input to set the RF equalizer LPF cut-off frequency.															

Pin No.	Symbol	I/O	Equivalent circuit	Description
27	BST C	I		Sets the high-frequency boost amount of RF equalizer.
28	RF C	I		Sets the low-frequency gain of RF amplifier and RF equalizer.
29	EQ IN	I		RF equalizer input.
30	SUM OUT	O		RF summing amplifier output inversion.
31	RFI	I		Mirror circuit input. The RF summing amplifier output is input.

Pin No.	Symbol	I/O	Equivalent circuit	Description
32	RFO	O		RF signal output. Eye pattern check point.

(Ta = 25°C, VCC = 2.5V, GND = VC, VEE = -2.5V)

Electrical Characteristics

No.	Measurement item	Symbol	SW conditions																Bias conditions			Measurement point	Description of output waveform and measurement method	Min.	Typ.	Max.	Unit
			S1	S2	S3	S4	S5	S6	S7	S8	S9	S10	S11	S12	S13	E1	E2	E3									
1	Current consumption	ICC																	0V	0.3V	0V	20	DC current measurement	21.5	33	46.5	mA
2	Current consumption	IEE																				7	DC current measurement	-46.5	-33	-21.5	mA
5	Offset voltage	V1-1																				32	DC current measurement	-65	100	275	mV
6	Voltage gain	G1-1	O	O																		32	V1 = 100mVp-p f = 100kHz	16	19	22	dB
7	VCA gain 1	G1-2	O	O																		32	V1 = 100mVp-p, f = 100kHz Difference for G1-1	-11.5	-8	-4.5	dB
8	VCA gain 2	G1-3	O	O																		32	V1 = 100mVp-p, f = 1kHz Difference for G1-1	4.5	8	11.5	dB
9	Frequency response	F1-1	O	O																		32	V1 = 100mVp-p, f = 10MHz Difference for G1-1	-3	-	-	dB
10	Maximum output amplitude H	V1-2	O	O																300mV		32	DC voltage measurement	1.75	2.25	-	V
11	Maximum output amplitude L	V1-3	O	O																-300mV		32	DC voltage measurement	-	-1.6	-0.95	V
12	Offset voltage	V2-1																		0V		15	DC voltage measurement	-60	0	60	mV
13	Voltage gain 1	G2-1	O																			15	V1 = 100mVp-p f = 1kHz	17.5	20.5	23.5	dB
14	Voltage gain 2	G2-2	O																			15	V1 = 100mVp-p f = 1kHz	17.5	20.5	23.5	dB
15	Voltage gain difference	G2-3																				15	G2-1 - G2-2	-2.5	0	2.5	dB
16	Frequency response 1	F2-1	O																			15	V1 = 100mVp-p, f = 20kHz Difference for G2-1	-3	-	-	dB
17	Frequency response 2	F2-2	O																			15	V1 = 100mVp-p, f = 20kHz Difference for G2-2	-3	-	-	dB
18	Maximum output amplitude H	V2-2	O																	300mV		15	DC voltage measurement	1.9	2.4	-	V
19	Maximum output amplitude L	V2-3	O																	300mV		15	DC voltage measurement	-	-2.3	-1.7	V

No.	Measurement item	Symbol	SW conditions													Bias conditions			Measurement point	Description of output waveform and measurement method	Min.	Typ.	Max.	Unit		
			S1	S2	S3	S4	S5	S6	S7	S8	S9	S10	S11	S12	S13	E1	E2	E3								
20	Offset voltage	V3-1									B							0V	0.3V	0V	13	DC voltage measurement	-60	30	150	mV
21	Voltage gain 1	G3-1																			13	V1 = 100mVp-p f = 1kHz	—	20.9	—	dB
22	Voltage gain 2	G3-2																			13	V1 = 100mVp-p f = 1kHz	—	20.9	—	dB
23	Voltage gain difference	G3-3																			13	G3-1 – G3-2	-2.0	0	2.0	dB
24	VCA gain 1	G3-4																			13	V1 = 100mVp-p, f = 1kHz	11.9	14.9	17.9	dB
25	VCA gain 2	G3-5																			13	V1 = 100mVp-p, f = 1kHz	23.9	26.9	29.9	dB
26	Frequency response 1	F3-1																			13	V1 = 100mVp-p, f = 20kHz Difference for G3-1	-3	—	—	dB
27	Frequency response 2	F3-2																			13	V1 = 100mVp-p, f = 20kHz Difference for G3-2	-3	—	—	dB
28	Frequency response 3	F3-3																			13	V1 = 100mVp-p, f = 180kHz Difference for G3-1	-3	—	—	dB
29	Frequency response 4	F3-4																			13	V1 = 100mVp-p, f = 180kHz Difference for G3-2	-3	—	—	dB
30	Maximum output amplitude H	V3-2																			13	DC voltage measurement	1.9	2.4	—	V
31	Maximum output amplitude L	V3-3																			13	DC voltage measurement	—	-2.2	-1.7	V

No.	Measurement item	Symbol	SW conditions										Bias conditions			Measurement point	Description of output waveform and measurement method	Min.	Typ.	Max.	Unit			
			S1	S2	S3	S4	S5	S6	S7	S8	S9	S10	S11	S12	S13							E1	E2	E3
32	Offset voltage	V4-1														0V	0.3V	0V	22		0.25	0.75	1.15	V
33	Offset voltage	V4-2																	21		0.25	0.8	1.15	V
34	Voltage gain 1	G4-1	O	O															22	V1 = 25mVp-p, f = 100kHz	17	22.5	26.5	dB
35	VCA gain 1	G4-2	O	O															22	V1 = 25mVp-p, f = 100kHz Difference for G4-1	4.5	8	10.5	dB
36	Boost gain	G4-3	O	O															22	V1 = 100mVp-p, f = 2MHz Difference for G4-1	1.5	4	6.5	dB
37	Frequency response 1	F4-1	O	O															22	V1 = 100mVp-p, f = 1MHz Difference for G1-1	-3	-	-	dB
38	Frequency response 2	F4-2	O	O								O							22	V1 = 100mVp-p, f = 10MHz Difference for G4-1	-3	-	-	dB
39	Frequency response 3	F4-3	O	O								O							22	V1 = 100mVp-p, f = 15MHz Difference for G4-1	-3	-	-	dB
40	Frequency response 4	F4-4	O	O								O							22	V1 = 100mVp-p, f = 20MHz Difference for G4-1	-3	-	-	dB
41	Maximum output amplitude H	V4-3	O	O												300mV			22	V4-3 - V4-1	0.45	0.85	-	V
42	Maximum output amplitude L	V4-4	O	O												-300mV			22	V4-1 - V4-4	0.45	0.9	-	V
43	Output noise	VN														0V			22	HPF = 400Hz, LPF = 200kHz	-	-	6	mV
45	High level output voltage	V5-1																	19	V1 = 0.8Vp-p, f = 10kHz	1.8	-	-	V
46	Low level output voltage	V5-2																	19	V1 = 0.8Vp-p, f = 10kHz	-	-	-2.2	V
47	Mirror hold frequency response	F5-1																	19	V1 = 0.8Vp-p, 55% AM Mod.	-	400	600	Hz
48	Bottom hold frequency response	F5-2																	19	V1 = 800mVp-p	-	550	900	Hz
49	Maximum operating frequency 1	F5-3																	19	V1 = 800mVp-p	40	-	-	kHz
50	Maximum operating frequency 2	F5-4																	19	V1 = 800mVp-p	250	-	-	kHz
51	Minimum input voltage	V5-3																	19	f (V1) = 10kHz	0.35	-	-	Vp-p
52	Maximum input voltage	V5-4																	19	f (V1) = 10kHz	-	-	1.8	Vp-p

No.	Measurement item	Symbol	SW conditions										Bias conditions			Measure- ment point	Description of output waveform and measurement method	Min.	Typ.	Max.	Unit				
			S1	S2	S3	S4	S5	S6	S7	S8	S9	S10	S11	S12	S13							E1	E2	E3	
53	Output voltage 1	V6-1								B							0V	69mV	0V	1	DC voltage measurement	—	-1.6	-0.9	V
54	Output voltage 2	V6-2																123mV		1	DC voltage measurement	-1.2	-0.35	1.4	V
55	Output voltage 3	V6-3																177mV		1	DC voltage measurement	0.3	1.6	—	V
56	Output voltage 4	V6-4											O					0V		1	DC voltage measurement	1.8	2.4	—	V
57	Output voltage 5	V6-5																0V		1	I1 = 0.8mADC DC voltage measurement	—	-0.9	0	V
58	Output voltage	VC																0.3V		16	DC voltage measurement	-0.1	0	0.1	V

Electrical Characteristics Measurement Circuit

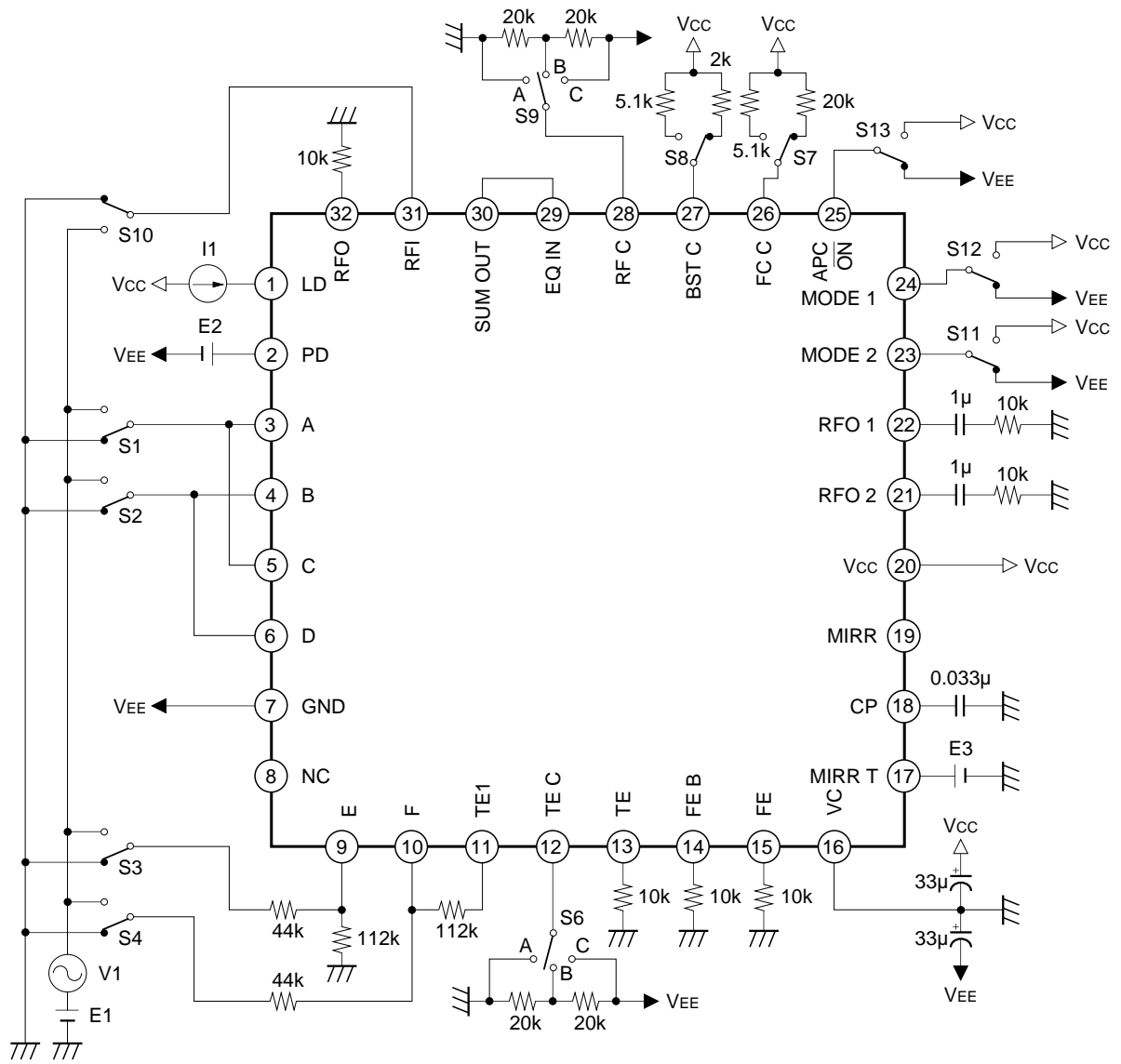

Application Circuit

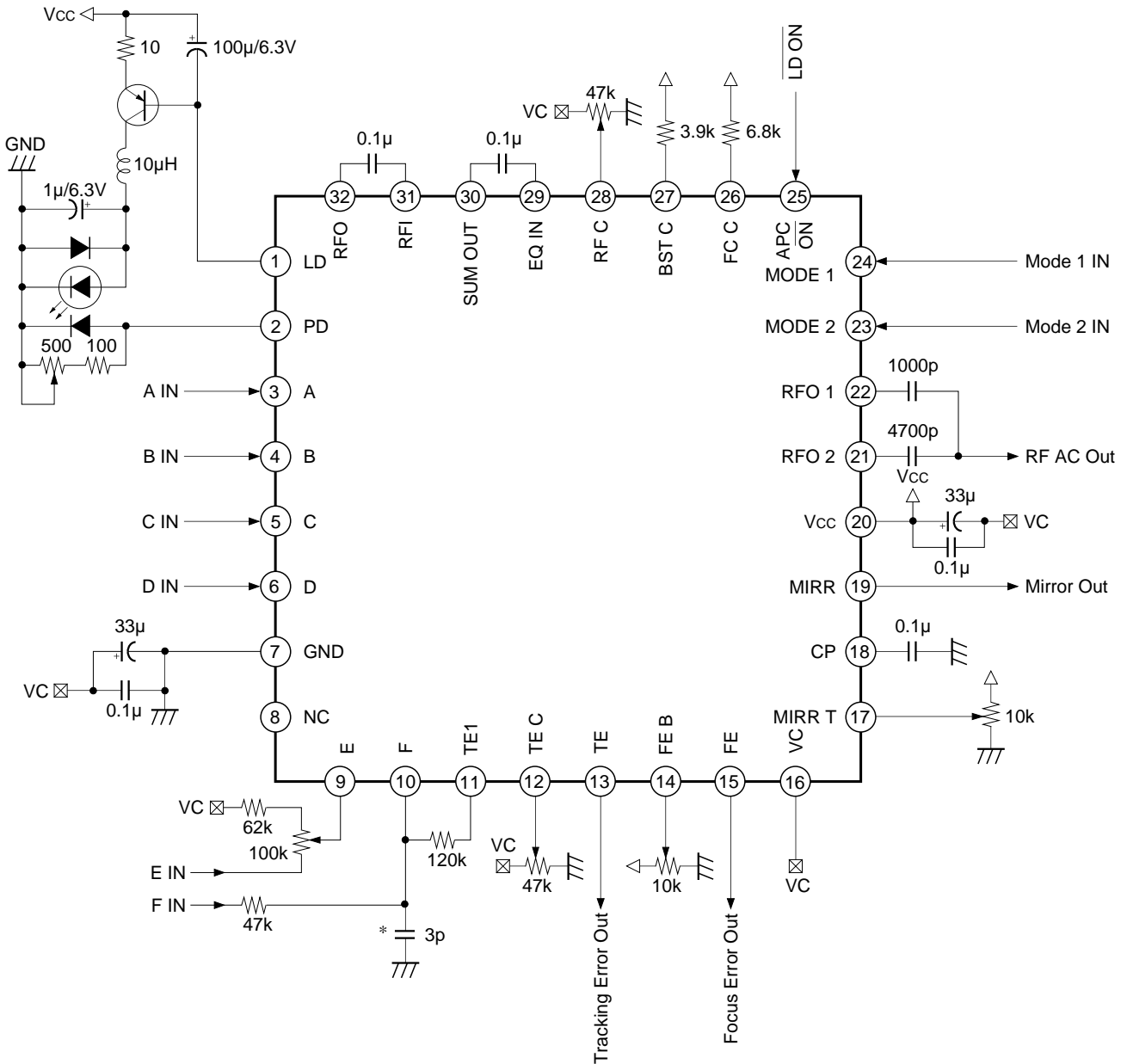

* Depending on actual applications an additional capacitor of 3pF may be added at pin (6). The purpose is to extend the cut-off frequency of TE to beyond 250kHz.

Application circuits shown are typical examples illustrating the operation of the devices. Sony cannot assume responsibility for any problems arising out of the use of these circuits or for any infringement of third party patent and other right due to same.

Description of Functions

RF Block

The RF signal processing is performed by this circuit.

The output is separated to AC and DC. The AC is the capacitance-coupled input via the equalizer circuit and used for the EFM demodulation signal processing. The DC contains the DC component and is used for the mirror, defect and FOK signal processings.

The VCA function is provided for both the AC and DC signal processing systems. Pin 28 is the control voltage input pin. (See the characteristics graphs on page 19 and page 20 for the gain and control voltage.)

RF Equalizer Block Diagram is as shown below:

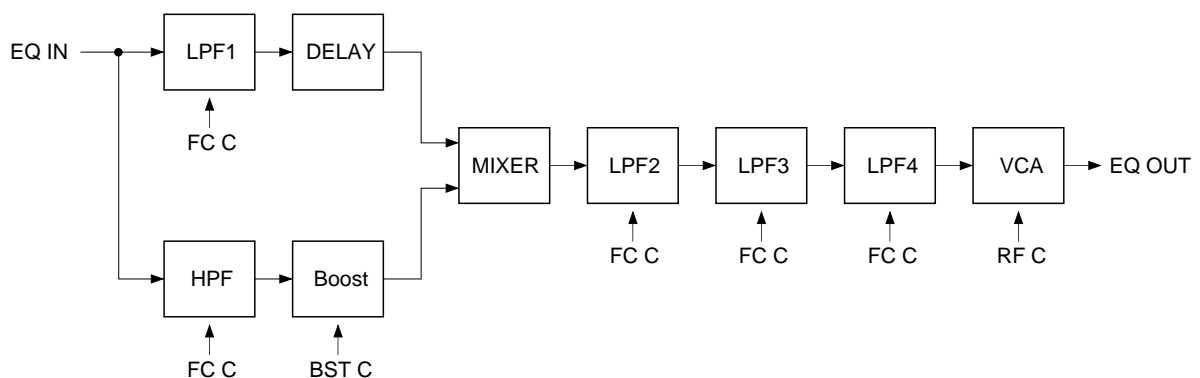

RF Equalizer

The equalizer function is provided for the AC signal processing system for the EFM signal demodulation.

The each filter is constructed in the Bessel type which has the little group delay difference.

The cut-off frequency and boost amount can be set by the external resistors connected to Pins 26 and 27.

(See the characteristics graphs on page 19 for the cut-off frequency and boost amount.)

The transmittance for each filter is as follows:

$$\text{HPF: } (KS^2) / (S^2 + 3.22597S + 2.94933)$$

$$\text{LPF1: } (2.94933) / (S^2 + 3.22597S + 2.94933)$$

$$\text{LPF2: } (3.32507) / (S^2 + 2.75939S + 3.32507)$$

$$\text{LPF3: } (4.20534) / (S^2 + 1.82061S + 4.20534)$$

$$\text{LPF4: } (1.68536) / (S + 1.68536)$$

RF Amplifier

The signal currents from the photodiodes A, B, C and D are I-V converted and input to Pins 3, 4, 5 and 6. These signals are added by the RF summing amplifier, inverted by the RF drive amplifier and output to Pin 32. The VCA control voltage on Pin 28 is used for the gain adjustment.

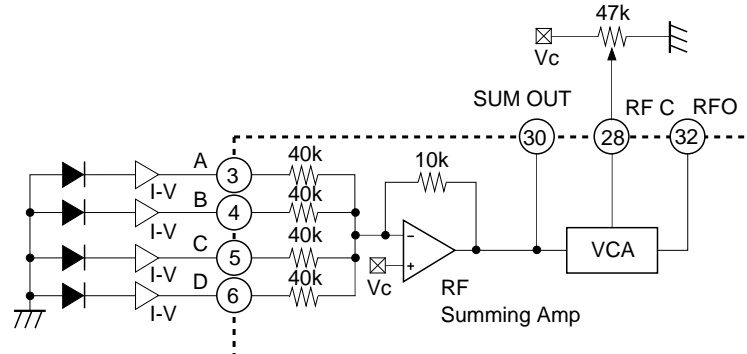

The low frequency component of the RFO output voltage is as follows:

$$V_{RFO} = 2.45 \times (A + B + C + D) \quad (\text{RFC voltage} = 1/2 \text{ VC})$$

Focus Error Amplifier

The operation of $(B + D) - (A + C)$ is performed and the resulting signal is output to Pin 15.

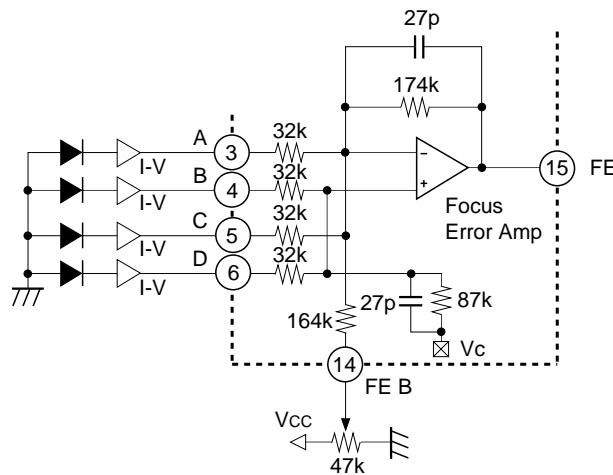

The low frequency component of the FE output voltage is as follows:

$$V_{FE} = \frac{174k}{32k} \times (B + D - A - C)$$

$$= 5.43 \times (B + D - A - C)$$

Tracking Error Amplifier

The signal current from the photodiode F is I-V converted and input to Pin 10 via the input resistor. The signal current from the photodiode E is I-V converted and input to Pin 9 after its gain is adjusted by the volume. These signals undergo operational amplification at the tracking error amplifier, VCA and tracking drive amplifier and they are output to Pin 13.

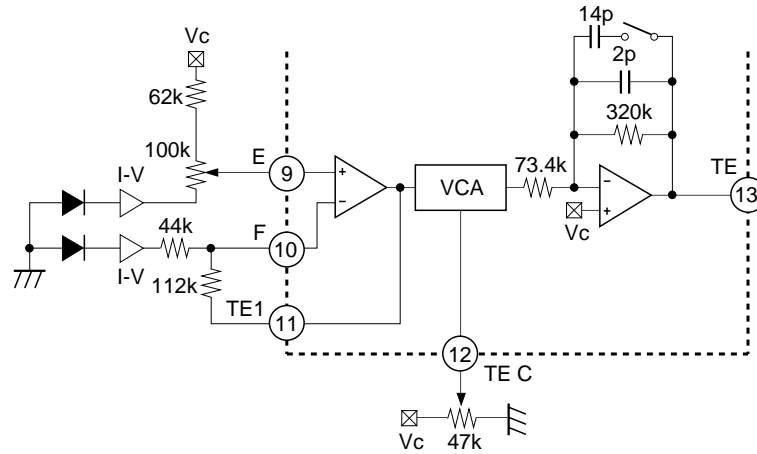

The low frequency component of the TE output voltage is as follows:

$$V_{TE} = \frac{112k}{44k} \times \frac{320k}{73.4k} \times (F - E)$$

$$= 11.1 \times (F - E) \quad (TE\ C\ voltage = 1/2\ VC)$$

Mirror Circuit

The mirror circuit performs peak and bottom hold after RFI signal has been amplified. The peak hold is executed with the time constant which follows the traverse signal of 100kHz for L/L mode (either of Pins 23 or 24 is connected to GND) and maximum 700kHz (adjustable with the DC voltage on Pin 17) for L/H, H/L, H/H modes. The bottom hold is executed with the time constant which follows the rotation cycle envelope fluctuation.

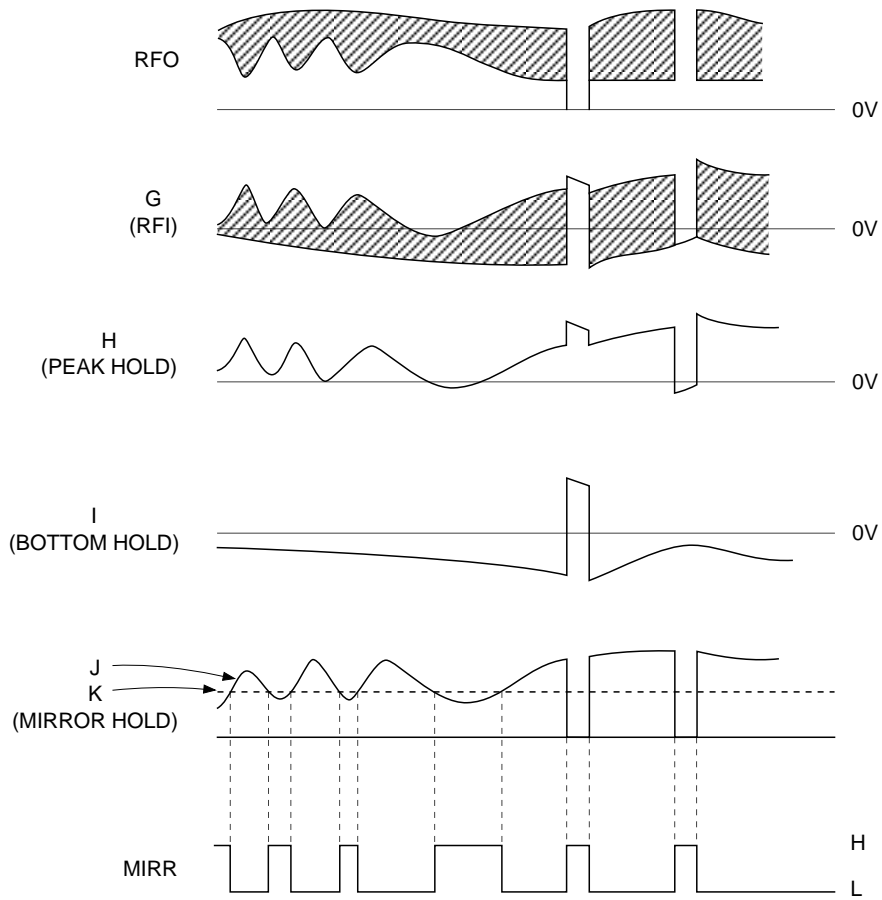
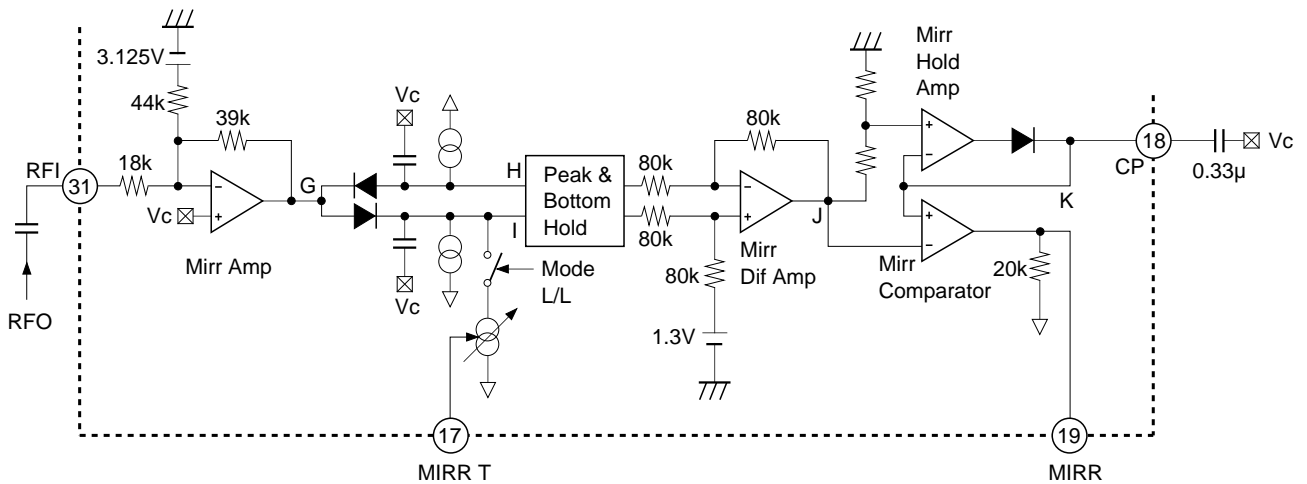

The mirror signal is output by comparing to the signal K (2/3 level of the J peak value which is peak-held with a large time constant) where the difference of hold signals H and I is obtained. The mirror output is low for tracks on the disc and high for the area between tracks (the mirror areas). In addition, a high signal is output when a defect is detected. The mirror hold time constant must be sufficiently large in comparison with the traverse signal.

Center Voltage Generation Circuit

The center voltage of $V_R = (V_{cc} + GND)/2$ is supplied. The maximum current is approximately $\pm 3mA$.

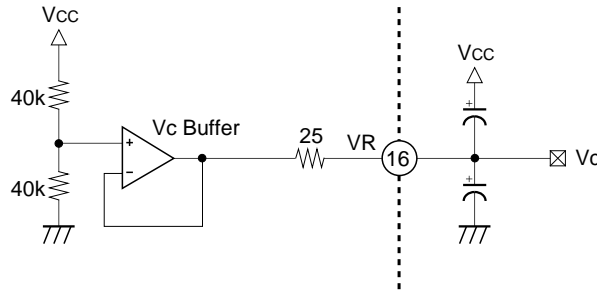

APC Circuit

When the laser diode is driven by a constant current, the optical power output has extremely large negative temperature characteristics.

The APC circuit is used to maintain the optical power output at a constant level. The laser diode current is controlled according to the monitor photodiode output.

APC is ON by connecting APC_ON pin to GND; it is OFF by connecting the pin to Vcc.

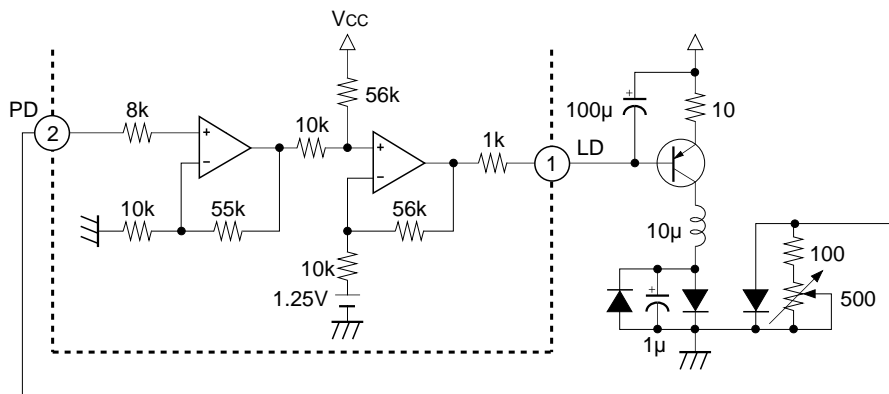

RF AC Characteristics Graphs (Pin 22)

Frequency response

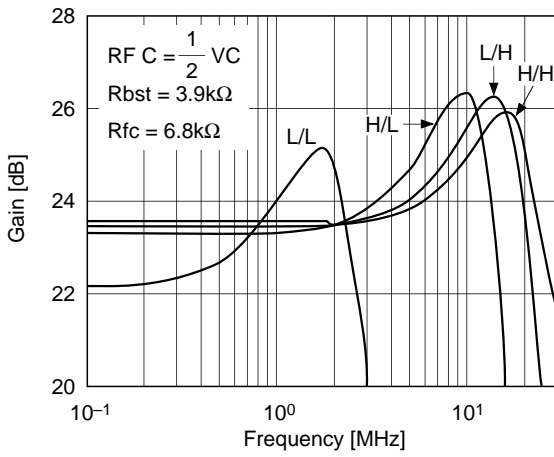

Boost gain characteristics

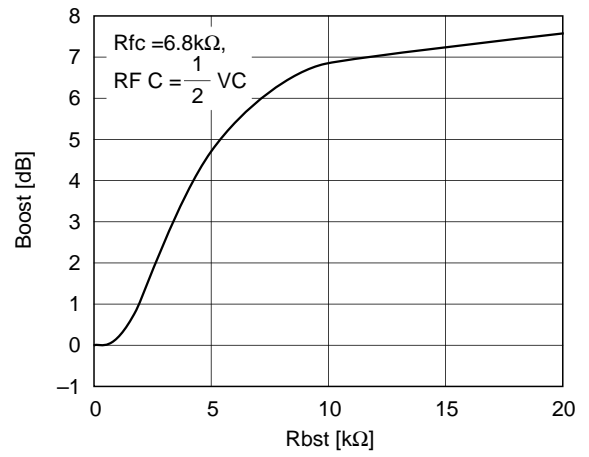

Cut-off frequency

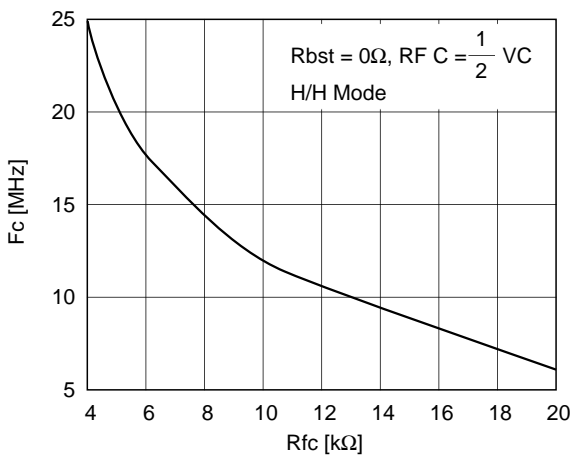

VCA characteristics

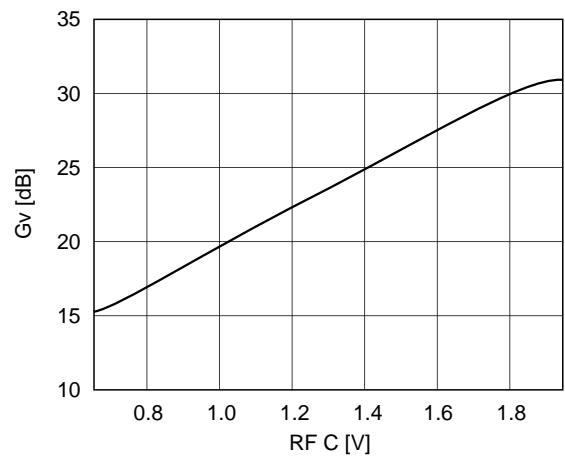

Notes) In the graphs above,

Rfc: FC C (pin 26) external resistor value

Rbst: BST C (pin 27) external resistor value

* To ensure stable operation, it is recommended to select Rfc value of 6.2kΩ and above, and Rbst of 10kΩ and below in all cases.

RF DC Characteristics Graphs (Pin 32)

Frequency response

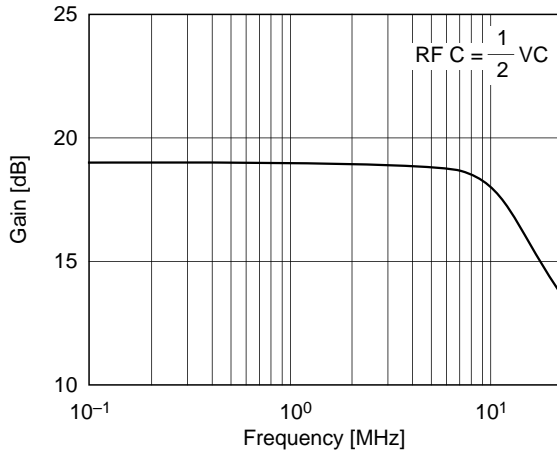

VCA characteristics

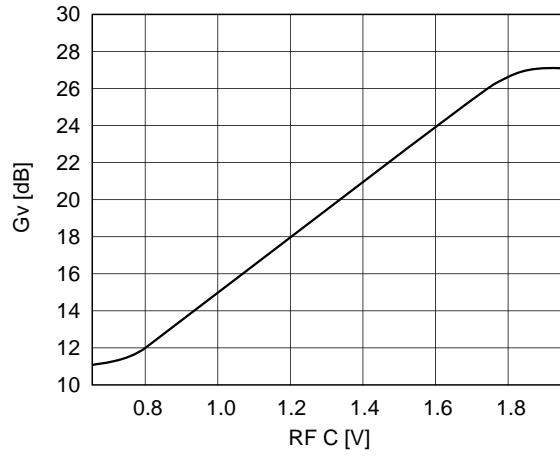

TE Characteristics Graphs (Pin 13)

Frequency response

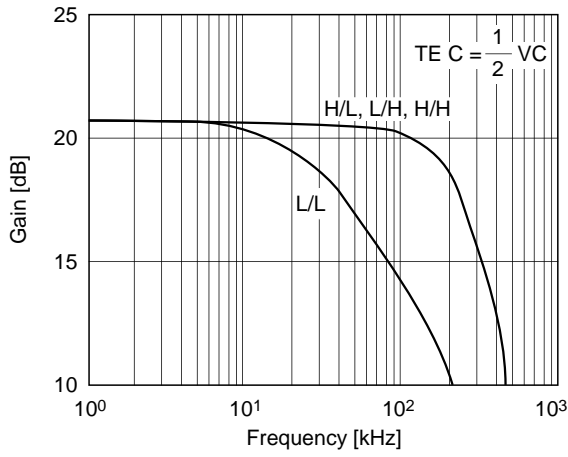

VCA characteristics

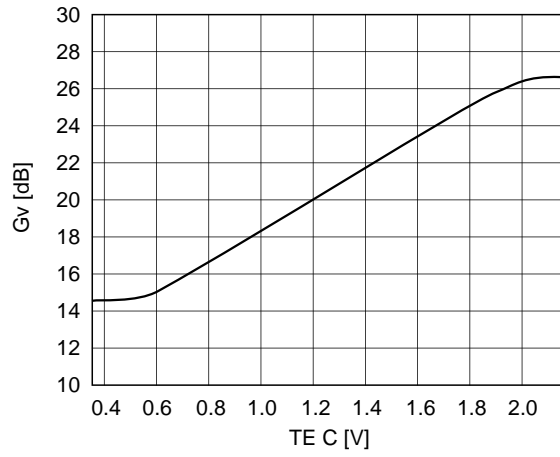

FE frequency response (Pin 15)

Frequency response

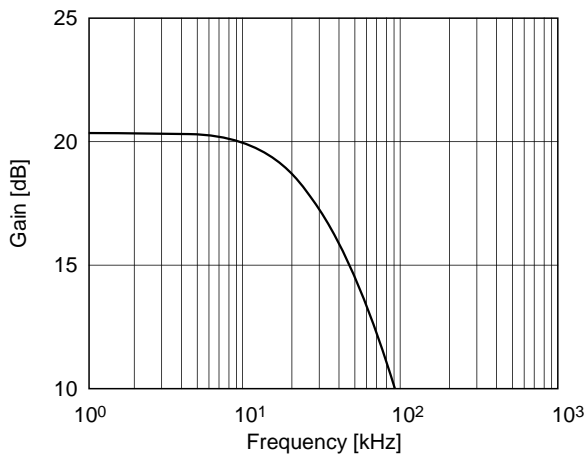

MIRROR Characteristics Graph (Pin 19)

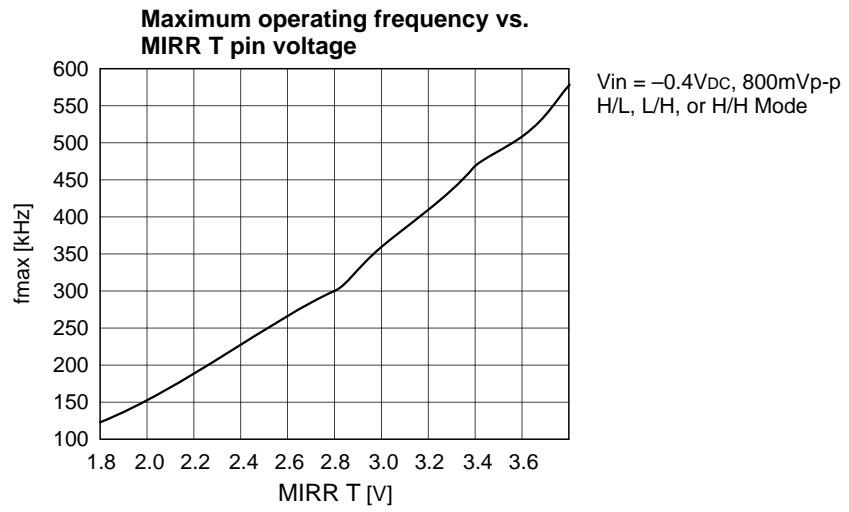

APC Characteristics Graph (Pin 1)

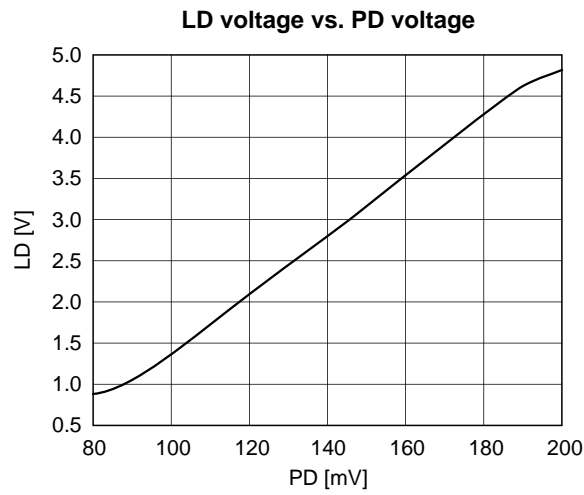

Package Outline Unit: mm

32PIN QFP (PLASTIC)

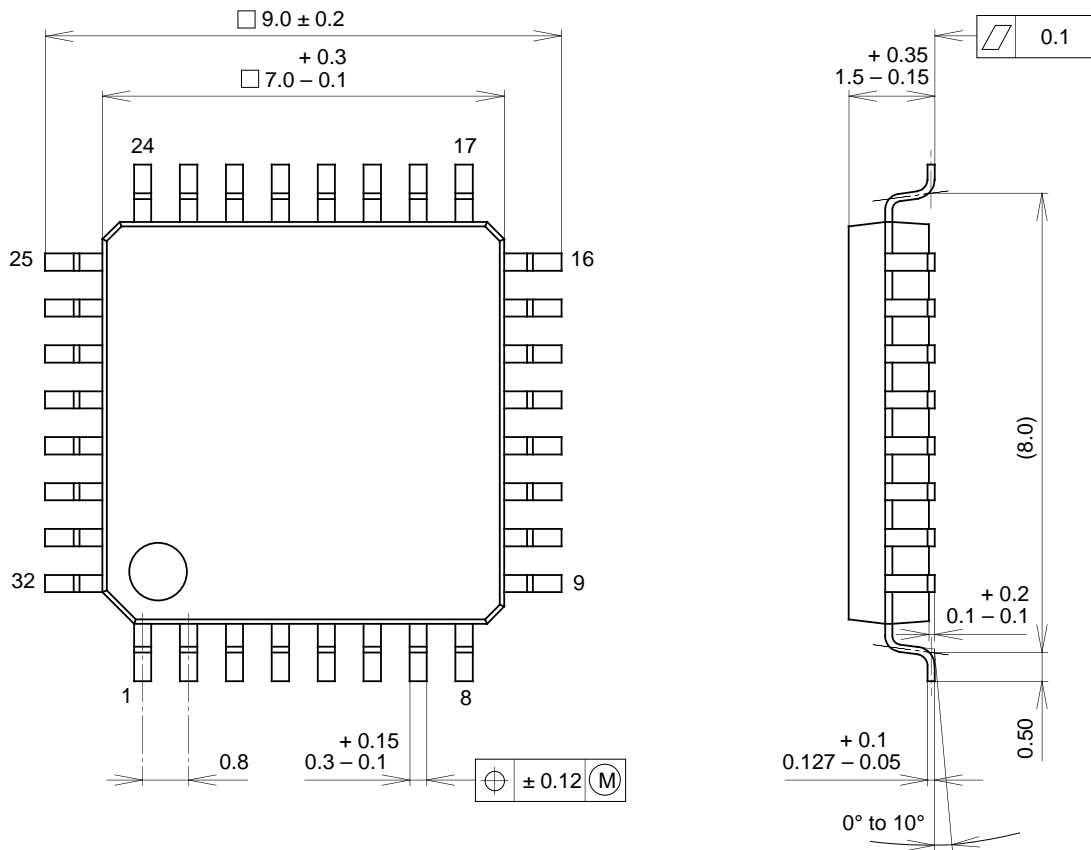

SONY CODE	QFP-32P-L01
EIAJ CODE	*QFP032-P-0707-A
JEDEC CODE	_____

PACKAGE MATERIAL	EPOXY RESIN
LEAD TREATMENT	SOLDER PLATING
LEAD MATERIAL	42 ALLOY
PACKAGE WEIGHT	0.2g

This datasheet has been downloaded from:

www.DatasheetCatalog.com

Datasheets for electronic components.



LittleDiode supplies new, hard to find or obsolete electronic components and semiconductors all over the world.

With over two million different components listed you are sure to find the part you need.

Feel free to visit us today at our online store:

LittleDiode.com

Looking forward to providing you with the best possible service.