

RF Signal Processing Servo Amplifier for CD Player

Description

The CXA2542AR is a bipolar IC developed for CD player RF signal processing and servo control.

Features

- Automatic focus bias adjustment circuit
- Automatic tracking balance and gain adjustment circuits
- RF level control circuit
- Interruption countermeasure circuit
- Anti-shock circuit
- Defect detection and prevention circuits
- RF I-V amplifier, RF amplifier
- APC circuit
- Focus and tracking error amplifier
- Focus, tracking and sled servo control circuits
- Focus OK circuit
- Mirror detection circuit
- Single power supply and dual power supplies

Applications

CD players

Structure

Bipolar silicon monolithic IC

48 pin LQFP (Plastic)

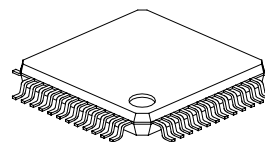

Absolute Maximum Ratings (Ta = 25°C)

• Supply voltage	V _{CC}	12	V
• Operating temperature	T _{opr}	–20 to +75	°C
• Storage temperature	T _{stg}	–65 to +150	°C
• Allowable power dissipation	P _D	1400	mW

Recommended Operating Conditions

Operating supply voltage	V _{CC} – V _{EE}	3.0 to 3.6	V
		4.5 to 5.5	V

Sony reserves the right to change products and specifications without prior notice. This information does not convey any license by any implication or otherwise under any patents or other right. Application circuits shown, if any, are typical examples illustrating the operation of the devices. Sony cannot assume responsibility for any problems arising out of the use of these circuits.

Block Diagram

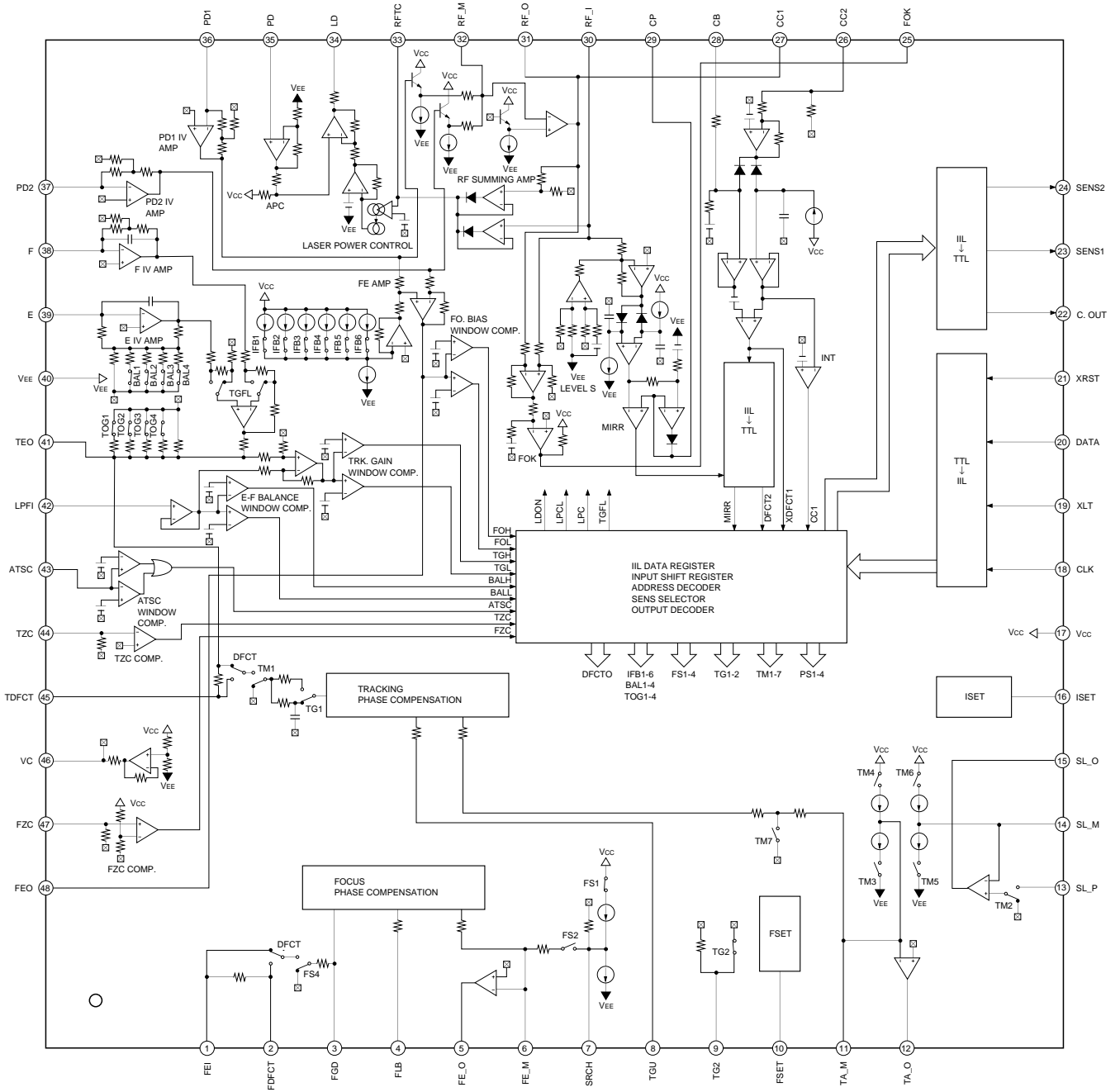

Pin Description

Pin No.	Symbol	I/O	Equivalent circuit	Description
1	FEI	I		Focus error input.
2	FDFCT	I		Connects the capacitor for defect time constant.
3	FGD	I		Ground this pin through a capacitor for cutting the focus servo high-frequency gain.
4	FLB	I		External time constant setting pin for boosting the focus servo low-frequency.
5	FE_O	O		Focus drive output.
12	TA_O	O		Tracking drive output.
15	SL_O	O		Sled drive output.
6	FE_M	I		Focus amplifier inverted input.
7	SRCH	I		External time constant setting pin for generating the focus search waveform.

Pin No.	Symbol	I/O	Equivalent circuit	Description
8	TGU	I		External time constant setting pin for switching the tracking high-frequency gain.
9	TG2	I		External time constant setting pin for switching the tracking high-frequency gain.
10	FSET	I		Peak frequency setting pin for focus and tracking phase compensation amplifier.
11	TA_M	I		Tracking amplifier inverted input.
13	SL_P	I		Sled amplifier non-inverted input.
14	SL_M	I		Sled amplifier inverted input.
16	ISET	I		Connect the external resistor to set the current which determines the Focus search, Track jump, and Sled kick levels.

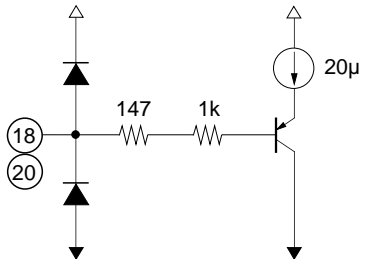
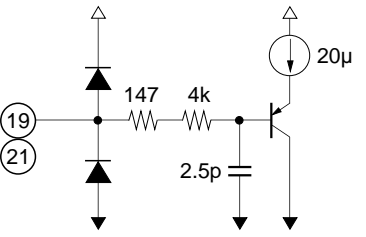
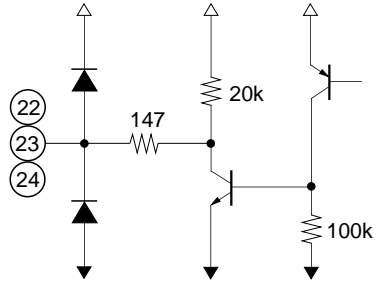
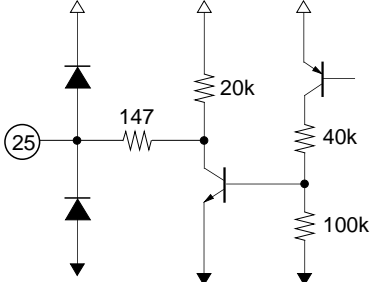
Pin No.	Symbol	I/O	Equivalent circuit	Description
17	Vcc	I		Positive power supply.
18	CLK	I		Serial data transfer clock input from CPU. (no pull-up resistance)
20	DATA	I		Serial data input from CPU. (no pull-up resistance)
19	XLT	I		Latch input from CPU. (no pull-up resistance)
21	XRST	I		Reset input; resets at Low. (no pull-up resistance)
22	C. OUT	O		Track number count signal output.
23	SENS1	O		Outputs FZC, DFCT1, TZC, BALH, TGH, FOH, ATSC, and others according to the command from CPU.
24	SENS2	O		Outputs DFCT2, MIRR, BALL, TGL, FOL, and others according to the command from the CPU.
25	FOK	O		Focus OK comparator output.

Pin No.	Symbol	I/O	Equivalent circuit	Description
26	CC2	I		Input for the RF summing amplifier output with capacitance coupled.
28	CB	I		Connects the defect bottom hold capacitor.
29	CP	I		Connects the MIRR hold capacitor. MIRR comparator non-inverted input.
30	RF_I	I		Input for the RF summing amplifier output with capacitance coupled.
31	RF_O	O		RF summing amplifier output. Eye-pattern check point.
32	RF_M	I		RF summing amplifier inverted input. The RF amplifier gain is determined by the resistance connected between this pin and RFO pin.
27	CC1	O		RF summing amplifier output. Used for the defect capacitance coupling.
33	RFTC	I		External time constant setting pin during RF level control.

Pin No.	Symbol	I/O	Equivalent circuit	Description
34	LD	O		APC amplifier output.
35	PD	I		APC amplifier input.
36 37	PD1 PD2	I I		RF I-V amplifier inverted input. Connect these pins to the photo diode A + C and B + D pins.
38 39	F E	I I		F I-V and E I-V amplifier inverted input. Connect these pins to photo diodes F and E pins.
40	V _{EE}	—		Negative power supply.

Pin No.	Symbol	I/O	Equivalent circuit	Description
41	TEO	O		Tracking error amplifier output. E-F signal is output.
45	TDFCT	I		Connects the capacitor for defect time constant.
42	LPFI	I		Comparator input for balance adjustment. (Input from TEO through LPF)
43	ATSC	I		Window comparator input for ATSC detection.
44	TZC	I		Tracking zero-cross comparator input.

Pin No.	Symbol	I/O	Equivalent circuit	Description
46	VC	O		($V_{CC} + V_{EE}$)/2 DC voltage output.
47	FZC	I		Focus zero-cross comparator input.
48	FEO	O		Focus error amplifier output. Connected internally to the window comparator input for bias adjustment.

Electrical Characteristics

(V_{CC} = 1.5V, V_{EE} = 1.5V, T_{opr} = 25°C)

TEST	Item	SW conditions (ON switches)	SD	Input pin	Measure- ment pin	Measurement conditions	Min.	Typ.	Max.	Unit
T1	Current consumption 1	19 (OFF)	RST	17	17		12.0	18.5	25.0	mA
T2	Current consumption 2	19 (OFF)	RST	40	40		-25.0	-18.5	-12.0	mA
T3	Center amplifier output offset	19 (OFF)	RST	—	46		-100	0	100	mV
T4	Offset		RST		31		-70	-13	70	mV
T5	RF amplifier Voltage gain	10, 13	RST	36 37	31	1kHz I/O ratio	16.5	19.5	22.5	dB
T6		10, 13	RST	36 37	31	V ₂ = 0.2VDC	1.2	1.4	—	V
T7		10, 13	RST	36 37	31	V ₂ = 0.2VDC	—	-1.3	-1.0	V
T8	Offset		39F		48	1FB6: ON	-120	0	120	mV
T9	Voltage gain 1	10	39F	36	48	1kHz I/O ratio	15.6	18.6	21.6	dB
T10	Voltage gain 2	13	39F	37	48	1kHz I/O ratio	15.6	18.6	21.6	dB
T11	Voltage gain difference		39F				-3	0	3	dB
T12	FE amplifier Max. output voltage – High	13	39F	37	48	V ₂ = 100mVDC	1	1.4	—	V
T13		10	39F	36	48	V ₂ = 100mVDC	—	-1.3	-1	V
T14	BIAS0		3BF		48	IFB1, 2, 3, 4, 5, 6: OFF	560	718	1042	mV
T15	BIAS1		3BE		48	IFB1: ON, BIAS0: reference	-29.0	-22.7	-16.5	mV
T16	BIAS2		3BD		48	IFB2: ON, BIAS0: reference Output gain difference with T15	5	6	7	dB
T17	BIAS3		3BB		48	IFB3: ON, BIAS0: reference Output gain difference with V17	5	6	7	dB
T18	BIAS4		3B7		48	IFB4: ON, BIAS0: reference Output gain difference with V18	5	6	7	dB
T19	BIAS5		3AF		48	IFB5: ON, BIAS0: reference Output gain difference with V19	5	6	7	dB
T20	BIAS6		39F		48	IFB6: ON, BIAS0: reference Output gain difference with V20	5	6	7	dB

TEST	Item	SW conditions (ON switches)	SD	Input pin	Measure- ment pin	Measurement conditions	Min.	Typ.	Max.	Unit
T21	FE amplifier FOH threshold value		39F		48	IFB6: ON Pin 1 voltage when SENS1 (Pin 23) goes from High to Low	5	20	35	mV
T22		FOL threshold value		39F		48	IFB6: ON Pin 1 voltage when SENS2 (Pin 24) goes from High to Low	-35	-20	-5
T23	Offset		34F 308	38 39	41	TOG: OFF, BAL1, 2, 3: ON	-25	0	25	mV
T24	GAIN UP (F)	14	36F 308	38	41	V1 = 2 kHz, I/O ratio TOG: OFF, BAL1, 2, 3: ON	7.2	10.2	13.2	dB
T25	GAIN UP (E)	15	36F 308	39	41	V1 = 2 kHz, I/O ratio TOG: OFF, BAL1, 2, 3: ON	7.2	10.2	13.2	dB
T26	Voltage gain F0	14	34F	38	41	V1 = 2kHz, TOG: OFF I/O ratio	1.2	4.2	7.2	dB
T27	Voltage gain F1	14	34E 30F	38	41	V1 = 2kHz, TOG1: ON Reference to F0	-2.3	-1.8	-1.3	dB
T28	Voltage gain F2	14	34D	38	41	V1 = 2kHz, TOG2: ON Reference to F0	-3.9	-3.4	-2.9	dB
T29	Voltage gain F3	14	34B	38	41	V1 = 2kHz, TOG3: ON Reference to F0	-6.9	-6.4	-5.9	dB
T30	Voltage gain F4	14	347	38	41	V1 = 2kHz, TOG4: ON Reference to F0	-11.1	-10.6	-10.1	dB
T31	Voltage gain E0	15	34F 30F 00	39	41	V1 = 2kHz, BAL: OFF I/O ratio	-1.6	1.4	4.4	dB
T32	Voltage gain E1	15	30E	39	41	V1 = 2kHz, BAL1: ON Reference to E0	0.16	0.46	0.76	dB
T33	Voltage gain E2	15	30D	39	41	V1 = 2kHz, BAL2: ON Reference to E0	0.58	0.88	1.18	dB
T34	Voltage gain E3	15	30B	39	41	V1 = 2kHz, BAL3: ON Reference to E0	1.43	1.73	2.03	dB
T35	Voltage gain E4	15	307	39	41	V1 = 2kHz, BAL4: ON Reference to E0	2.96	3.26	3.56	dB
T36	Max. output voltage – High	1	34F 308	38	41	V1 = 1VDC, TOG: OFF, BAL1, 2, 3: ON	0.5	0.7	—	V
T37	Max. output voltage – Low	1	34F 308	39	41	V1 = 1VDC, TOG: OFF, BAL1, 2, 3: ON	—	-0.8	-0.5	V
T38	Output voltage 1		3C4	35	34	I1 = 364μA	-900	-704	-500	mV
T39	Output voltage 2		3C4	35	34	I1 = 439μA	-693	-293	107	mV
T40	Output voltage 3		3C4	35	34	I1 = 515μA	163	613	1063	mV
T41	Output voltage 4	9	3C4	35	34	0.8mA sink	-200	132	500	mV
T42	LD OFF		3C0	35	34	I1 = 515μA, LD: OFF	1.1	1.3	—	V

TEST	Item	SW conditions (ON switches)	SD	Input pin	Measurement pin	Measurement conditions	Min.	Typ.	Max.	Unit
T43	50% limit	8	3C7	35 30	34	I1 = 273μA Output difference with LPC ON/OFF	725	1330	1935	mV
T44	30% limit	8	3C5	35 30	34	I1 = 333μA Output difference with LPC ON/OFF	315	915	1515	mV
T45	-50% limit	10, 13	3C7	35 36 37	34	I1 = 742μA Output difference with LPC ON/OFF	-1421	-816	-211	mV
T46	-30% limit	10, 13	3C5	35 36 37	34	I1 = 667μA Output difference with LPC ON/OFF	-1215	-615	-15	mV
T47	DC voltage gain	1	08	1	5		17.4	20.9	24.4	dB
T48	FCS total gain		—	—	—	T9 + T47	37.5	39.5	41.5	dB
T49	Feed through 1	1	00 08	1	5	I/O gain difference between SD = 00 and SD = 08	—	—	-30	dB
T50	FZC threshold value	20	00	47	47	Pin 47 voltage when SENS1 (Pin 23) goes from Low to High	123	150	177	mV
T51	Max. output voltage – High	1	08	1	5	V1 = 200mVDC	1	1.3	—	V
T52	Max. output voltage – Low	1	08	1	5	V1 = -200mVDC	—	-1.3	-1	V
T53	Search voltage (-)		02	—	5		-721	-581	-441	mV
T54	Search voltage (+)		03	—	5		399	539	679	mV
T55	DC voltage gain		25	38	12	DC gain between TEO and TA_O	11.4	14.6	17.8	dB
T56	TRK total gain		—	—	—	T26 + T55	16.8	18.8	20.8	dB
T57	Feed through 1		20 25	38	12	I/O gain difference between SD = 20 and SD = 25.	—	—	-39	dB
T58	Max. output voltage – High		20 25	38	12	V1 = -0.3VDC	1	1.3	—	V
T59	Max. output voltage – Low		20 25	38	12	V1 = 0.3VDC	—	-1.3	-1	V
T60	Jump output voltage (-)		2C		12		-652	-512	-372	mV
T61	Jump output voltage (+)		28		12		437	577	717	mV
T62	ATSC threshold value (-)	5, 17	10	43	43	Input voltage when TG2 (Pin 9) goes from Vcc/2 to Vcc	-25	-15	-7	mV
T63	ATSC threshold value (+)	5, 17	10	43	43	Input voltage when TG2 (Pin 9) goes from Vcc/2 to Vcc	7	15	25	mV
T64	TZC threshold value	18	20	44	44	Pin 44 voltage when SENS1 (Pin 23) is 0V	-20	0	20	mV

TEST	Item	SW conditions (ON switches)	SD	Input pin	Measurement pin	Measurement conditions	Min.	Typ.	Max.	Unit
T65	BAL COMP threshold value – High	16	300	42	42	Pin 42 voltage when SENS1 (Pin 23) goes from High to Low	5	20	35	mV
T66	BAL COMP threshold value – Low	16	300	42	42	Pin 42 voltage when SENS2 (Pin 24) goes from High to Low	-35	-20	-5	mV
T67	GAIN COMP threshold value – High	14	308 34F	38	41	Pin 41 voltage when SENS1 (Pin 23) goes from High to Low	168	193	218	mV
T68	GAIN COMP threshold value – Low	14	308 34F	38	41	Pin 41 voltage when SENS2 (Pin 24) goes from Low to High	127	145	163	mV
T69	FOK threshold value	8	—	30	25	Pin 30 voltage when Pin 25 is 0V	-560	-510	-450	mV
T70	Voltage gain	6, 7	25	13	15	V1 = 100Hz, I/O ratio	50	—	—	dB
T71	Feed through	6	20 25	13	15	I/O gain difference between SD = 20 and SD = 25.	—	—	-34	dB
T72	Max. output voltage – High	6	25	13	15	V1 = 400mVDC	1	1.3	—	V
T73	Max. output voltage – Low	6	25	13	15	V1 = 400mVDC	—	-1.3	-1	V
T74	Kick voltage 1		20	—	15	REV × 1	-750	-600	-450	mV
T75	Kick voltage 2		20	—	15	FWD × 1	450	600	750	mV
T76	Max. operating frequency 1	8	20	30	24	Measures at SENS2 pin.	30	—	—	kHz
T77	Min. input operating voltage 1	8	20	30	24	Measures at SENS2 pin.	—	—	0.3	Vp-p
T78	Max. input operating voltage 1	8	20	30	24	Measures at SENS2 pin.	1.8	—	—	Vp-p
T79	Min. operating frequency 1	10, 11, 12, 13	10	36 37	23	Measures at SENS1 pin.	—	—	1	kHz
T80	Max. operating frequency 1	10, 11, 12, 13	10	36 37	23	Measures at SENS1 pin.	2.5	—	—	kHz
T81	Min. input operating voltage 1	10, 11, 12, 13	10	36 37	23	Measures at SENS1 pin.	—	—	0.5	Vp-p
T82	Max. input operating voltage 1	10, 11, 12, 13	10	36 37	23	Measures at SENS1 pin.	1.6	—	—	Vp-p

Electrical Characteristics Measurement Circuit

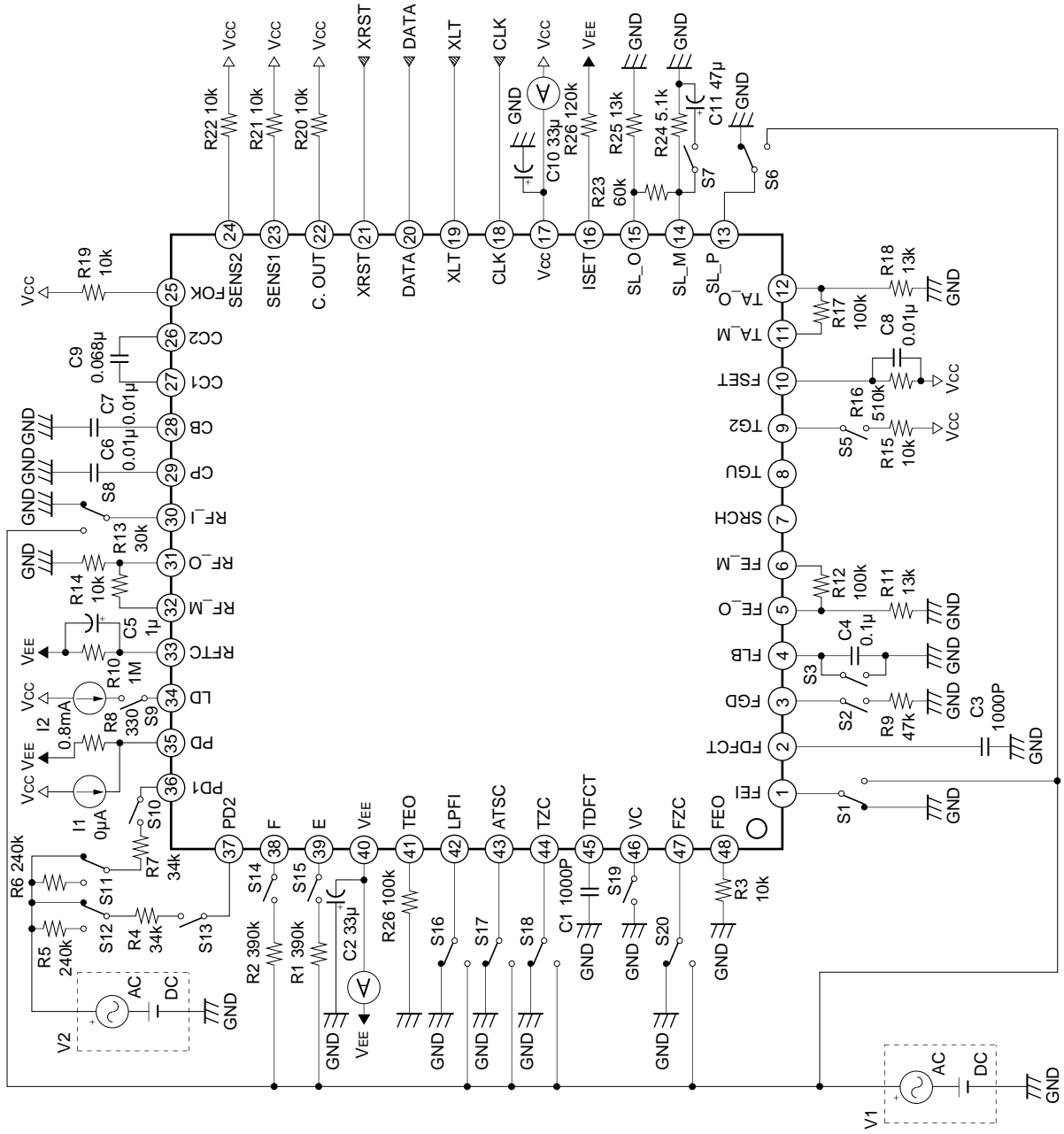

Description of Functions

RF Amplifier

The photodiode currents input to the input pins (PD1 and PD2) are each I-V converted through a 58kΩ equivalent resistor by the PD I-V amplifiers. These signals are added by the RF summing amplifier, and the photodiode (A + B + C + D) current-voltage converted voltage is output to the RFO pin. An eye-pattern check can be performed at this pin.

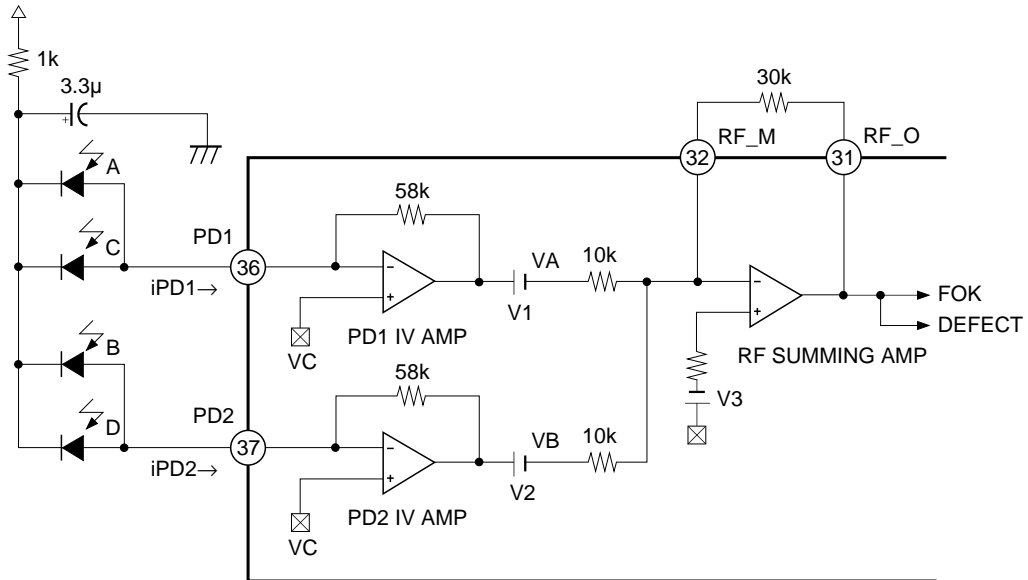

The low frequency component of the RFO output voltage is

$$V_{RFO} = -\frac{30k}{10k} (VA + VB - 2V3) + V3$$

$$= -3 \{-58k\Omega (iPD1 + iPD2) + V1 + V2 - 2V3\} + V3, \text{ and}$$

the setting is $V1 = V2 = V3$, then

$$V_{RFO} = 174k\Omega \times (iPD1 + iPD2) + V3$$

Focus Error Amplifier

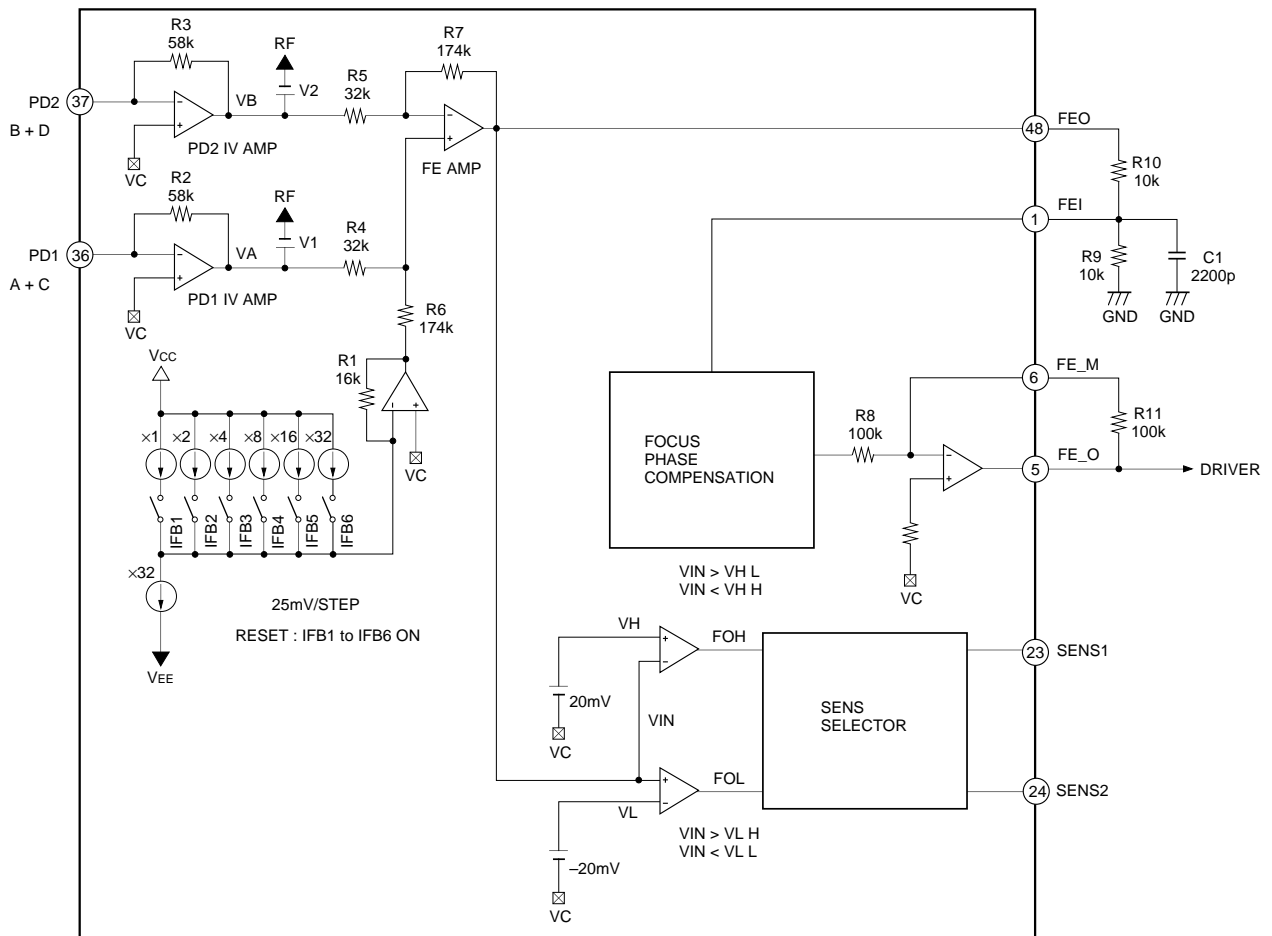

The focus error amplifier calculates the difference between outputs VA and VB of the RF I-V amplifier, and outputs current-voltage converted voltage of the photodiode (A + C – B – D).

The FEO output voltage:

$$\begin{aligned}
 V_{FEO} &= \frac{174k\Omega}{32k\Omega} (VA - VB) \\
 &= \frac{174k\Omega}{32k\Omega} \{(-58k\Omega \times i_{PD1}) - (-58k\Omega \times i_{PD2})\} \\
 &= 315.4k\Omega (i_{PD2} - i_{PD1})
 \end{aligned}$$

The focus error amplifier has a built-in bias adjustment circuit to enable software-based automatic adjustment. The focus bias adjustment is performed by turning the focus bias adjustment switches (IFB1 to IFB6) ON and OFF.

The 6-bit focus bias adjustment switches are controlled with commands.

IFB1 to IFB6 are all ON after a reset.

The voltage is varied by approximately 25mV per step.

• Focus error amplifier offset adjustment (when adjusting the IC offset)

The offset adjustment is performed by comparing the FEO when the focus servo is OFF with the reference level.

The FEO and reference level are compared by the window comparator, and the comparison results are output from SENS1 and SENS2. (ADDRESS $D^{11}001110^{D6}$)

Adjust the offset so that SENS1 and SENS2 are both High.

Set the reference level to the center $\pm 20\text{mV}$.

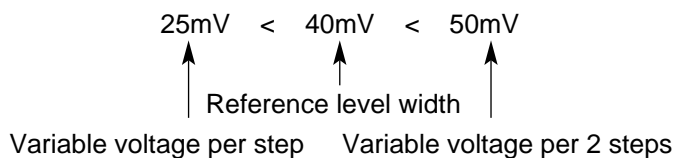
**• Focus bias fine adjustment**

Fine adjustment is performed by turning the focus bias adjustment switches (IFB1 to IFB6) ON and OFF while monitoring a DSP jitter meter with the microcomputer.

The 6-bit focus bias adjustment switches are controlled with commands.

Tracking Error Amplifier

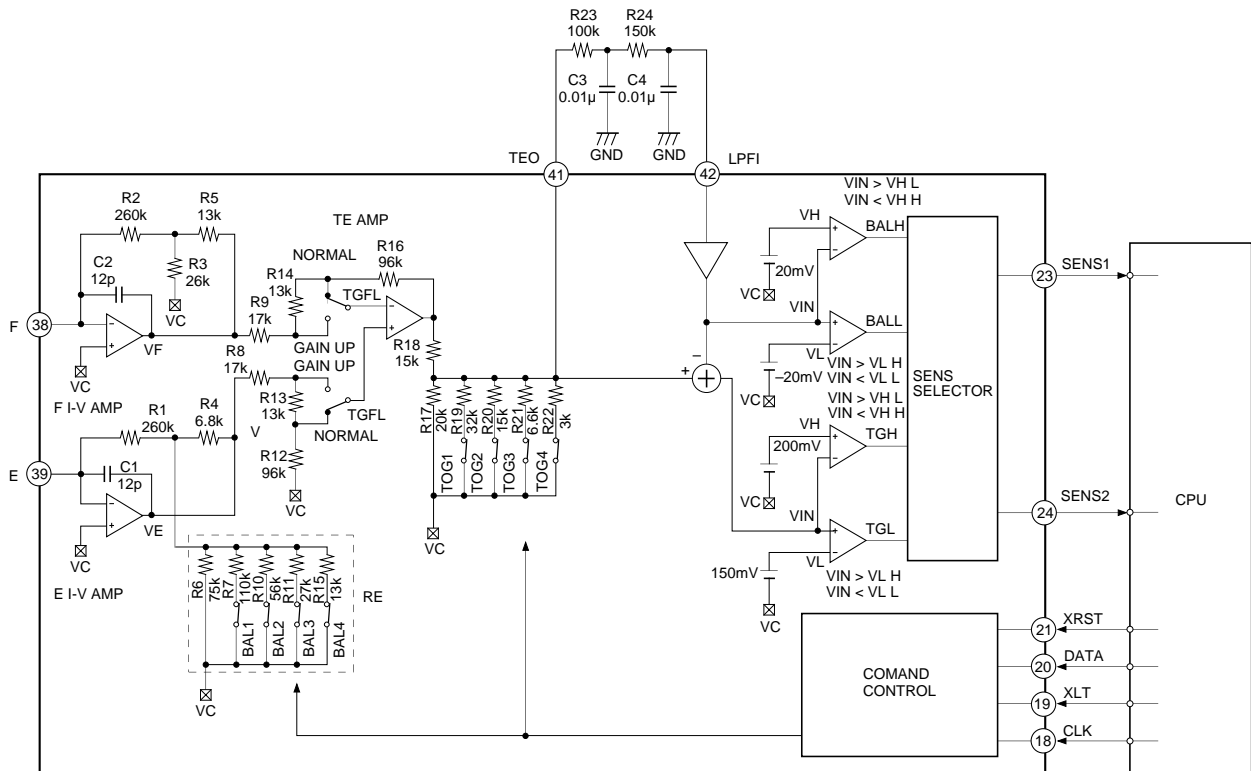

The difference between E I-V amplifier output VE and F I-V amplifier output VF is taken and output from TEO.

The tracking error amplifier has built-in balance and gain adjustment circuits to enable software-based automatic adjustment.

The balance adjustment is performed by varying the combined resistance value of the T-configured feedback resistance at the E I-V amplifier.

$$\text{E I-V AMP feedback resistance} = R1 + R4 + \frac{R1 \times R4}{RE}$$

$$\text{F I-V AMP feedback resistance} = R2 + R5 + \frac{R2 \times R5}{R3} = 403k\Omega$$

Vary the combined resistance value of the E I-V amplifier's feedback resistance by using the balance adjustment switches (BAL1 to BAL4).

The gain adjustment is performed by resistance dividing the TE AMP output by the gain adjustment switches (TOG1 to TOG4).

The balance and gain adjustment switches are controlled with commands.

Set the cut-off frequency of the external LPF between 10Hz and 100Hz.

• Balance adjustment

The balance adjustment is performed by passing the tracking error signal (TEO signal) through the external LPF, extracting the offset DC, and comparing it to the reference level.

However, the TEO signal frequency distribution ranges from DC to 2kHz. Merely sending the signal through the LPF leaves lower frequency components, and the complete offset DC can not be extracted.

To extract it, monitor the TEO signal frequency at all times, and perform adjustment only when a frequency that can lower a sufficient gain appears on the LPF.

Use the C.OUT output to check this frequency.

The offset DC and reference level are compared by the window comparator.

The comparison signal is output from the SENS1 and SENS2 pins. (ADDRESS ^{D11}001100^{D6})

Adjust the balance so that the SENS1 and SENS2 pins are both High.

	$V_{IN} < V_L < V_H$	$V_L < V_{IN} < V_H$	$V_L < V_H < V_{IN}$
SENS1 pin BALH	H	H	L
SENS2 pin BALL	L	H	H

V_H: High level threshold value

V_{IN}: Window comparator input signal

V_L: Low level threshold value

• Gain adjustment

Gain adjustment is performed by passing the TEO signal through the HPF and comparing the AC component to the reference level.

The AC component is generated by taking the difference between TE and the offset DC input to Pin 42.

The AC component and reference level are compared by the window comparator.

The comparison signal is output from the SENS1 and SENS2 pins. (ADDRESS ^{D11}001101^{D6})

The comparison signal is as follows.

	(1)	(2)	(3)
SENS1 pin TGH	H	H	Low
SENS2 pin TGL	L	High	High

The gain should be adjusted so that the SENS1 and SENS2 pins are as shown in status (2).

When the TEO signal level is low and TGH (SENS1 pin) does not go Low, the gain should be raised with the TGFL command for adjustment. If the adjustment does not bring the result of Low, check the pulse duty of TGL (SENS2 pin).

APC & Laser Power Control

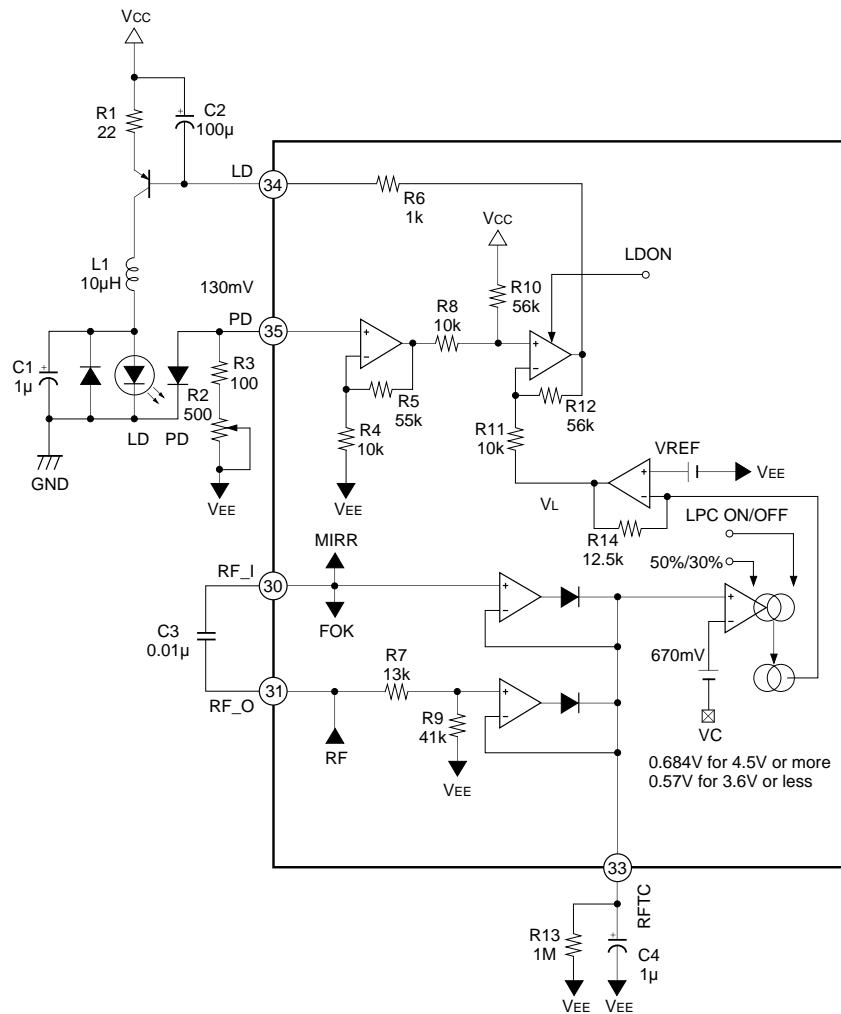

• APC

When the laser diode is driven by a constant current, the optical power output has extremely large negative temperature characteristics.

The APC circuit is used to maintain the optical power output at a constant level.

The laser diode current is controlled according to the monitor photodiode output.

• Laser power control

The RF level is stabilized by attaching an offset to the APC VL and controlling the laser power in sync with the RF level fluctuations.

The RF_O and RF_I levels are compared and the larger of the two is smoothed by the RFTC's external CR.

This signal is then compared with the reference level.

The laser power is controlled by attaching an offset to VL according to the results of comparison with the reference level.

The reference level is set to 0.57V for the power supply of 3.6V or less and to 0.684V for 4.5V or more.

LPC ON/OFF and LD ON/OFF control is performed with commands.

The laser power control limit can also be switched between ±50% and ±17% with commands.

LPC	LPCL	VL variable range
OFF	—	Approximately 1.27V
ON	±50%	Approximately 1.27V ± 625mV
ON	±30%	Approximately 1.27V ± 375mV

Center Voltage Generation Circuit

(The figure below shows a single voltage application; Connect to GND for dual power supplies.)
 The maximum current is approximately $\pm 3\text{mA}$. The output impedance is approximately 50Ω .

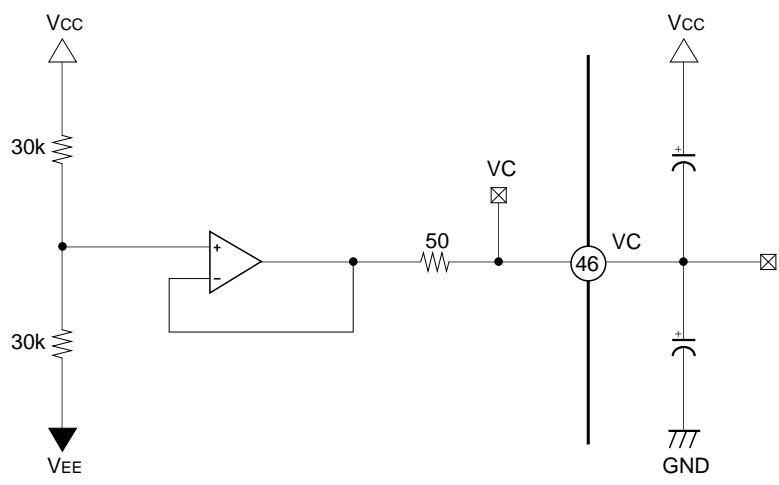

Connected internally to the VEE pin.

Focus Servo

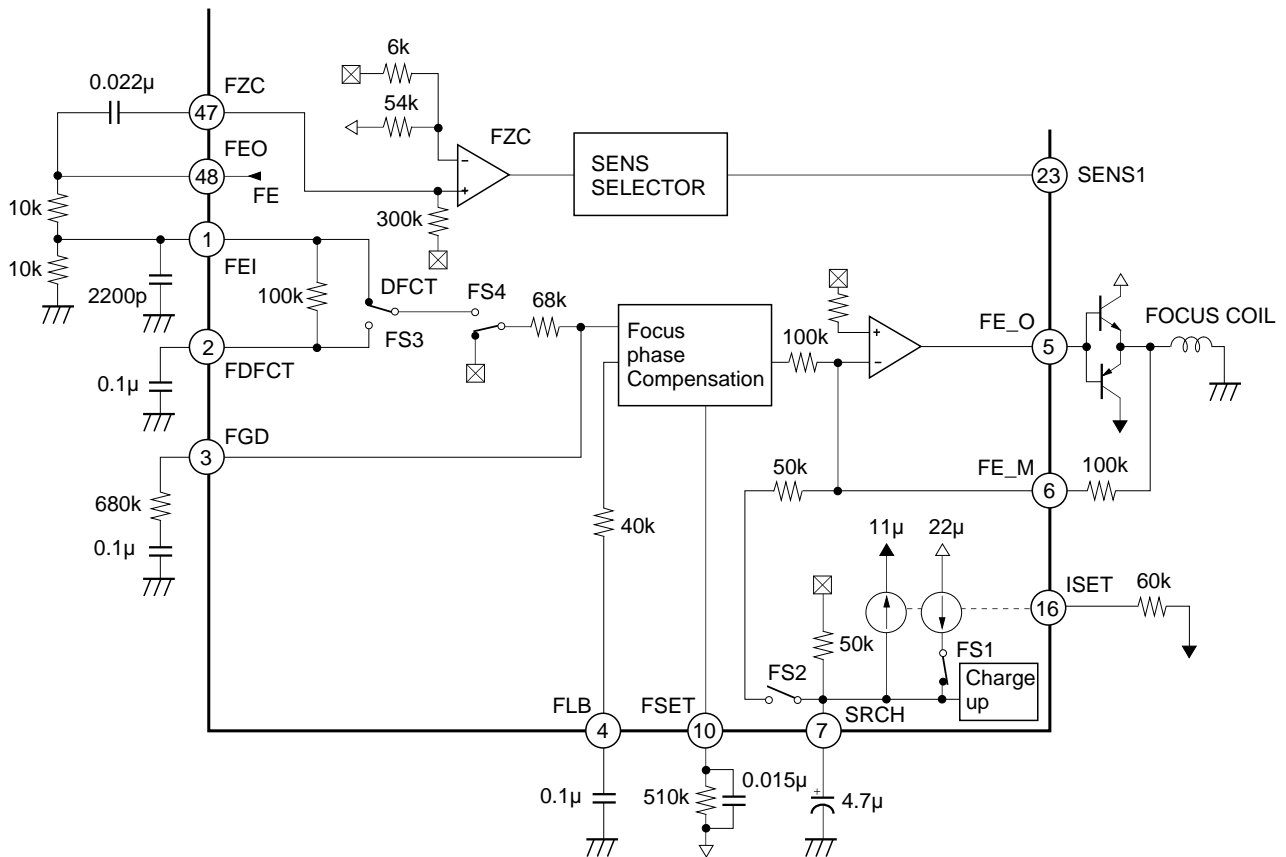

The above figure shows a block diagram of the focus servo.

Ordinarily the FE signal is input to the focus phase compensation circuit through a 68kΩ resistance; however, when DFCT is detected, the FE signal is switched to pass through a low-pass filter formed by the internal 100kΩ resistance and the capacitance connected to Pin 2. When this DFCT prevention circuit is not used, leave Pin 2 open. The defect switch operation can be enabled and disabled with command.

The capacitor connected between Pin 4 and GND is a time constant to boost the low frequency in the normal playback state.

The peak frequency of the focus phase compensation is approximately 1.2kHz when a resistance of 510kΩ is connected to Pin 10.

The focus search level is approximately ±1.1Vp-p when using the constants indicated in the above figure. This level is inversely proportional to the resistance connected between Pin 16 and VEE. However, changing this resistance also changes the level of the track jump and sled kick as well.

The FZC comparator inverted input is set to 10% of Vcc and VC (Pin 46); $(V_{cc} - V_C) \times 10\%$.

* 510kΩ resistance is recommended for Pin 10.

Tracking and Sled Servo

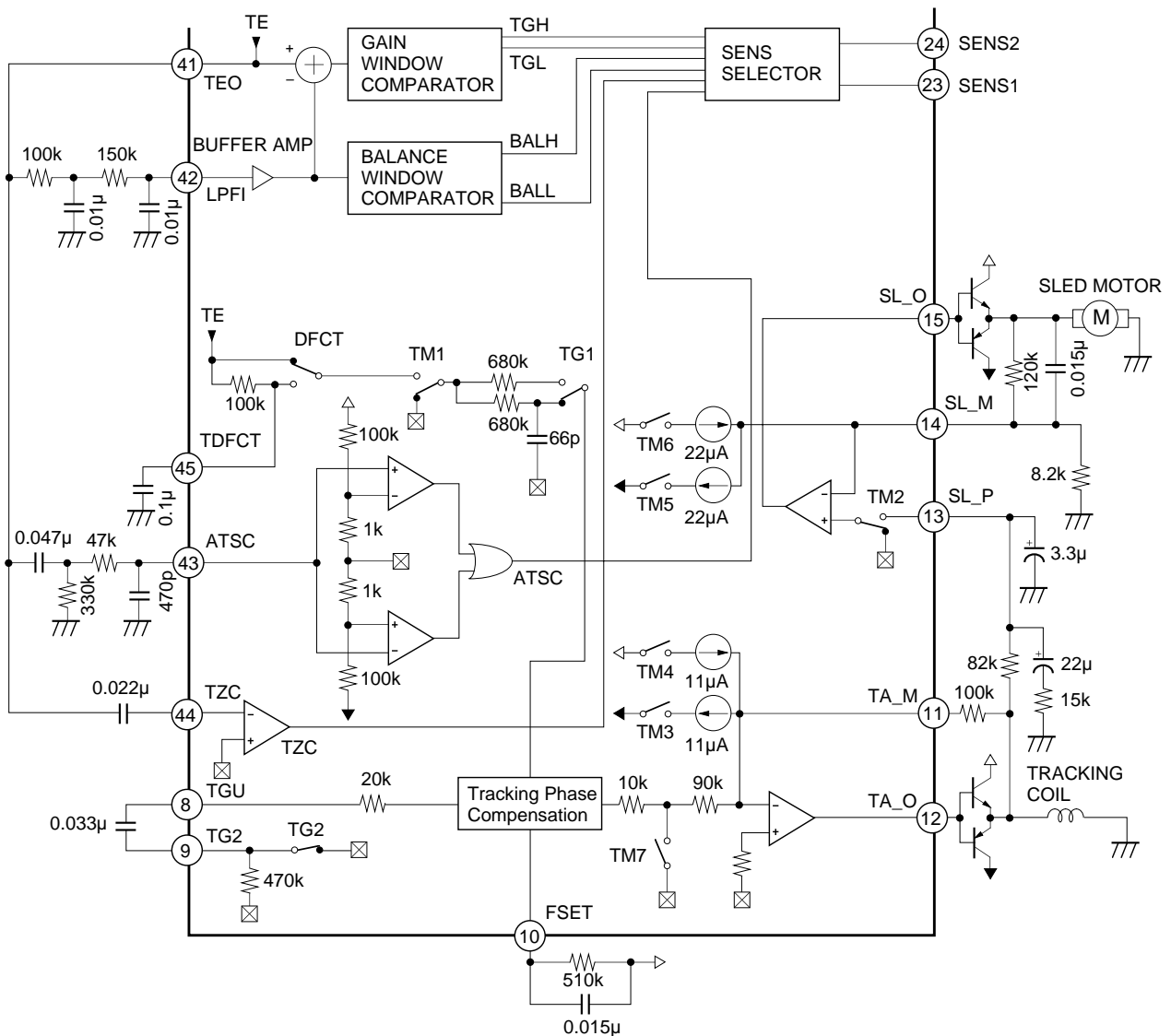

The above figure shows a block diagram of the tracking and sled servo.

The capacitor connected between Pins 8 and 9 is a time constant to cut the high-frequency gain when TG2 is OFF. The peak frequency of the tracking phase compensation is approximately 1.2kHz when a 510kΩ resistance is connected to Pin 10. In the CXA2542AR, TG1 and TG2 are inter-linked switches.

To jump tracks in FWD and REV directions, turn TM3 or TM4 ON. During this time, the peak voltage applied to the tracking coil is determined by the TM3 or TM4 current and the feedback resistance from Pin 11. To be more specific,

$$\text{Track jump peak voltage} = \text{TM3 (or TM4) current} \times \text{feedback resistance value}$$

The FWD and REV sled kick is performed by turning TM5 or TM6 ON. During this time, the peak voltage applied to the sled motor is determined by the TM5 or TM6 current and the feedback resistance from Pin 14;

$$\text{Sled kick peak voltage} = \text{TM5 (or TM6) current} \times \text{feedback resistance}$$

The values of the current for each switch are determined by the resistance connected between Pin 16 and V_{EE}. When this resistance is 60kΩ :

$$\text{TM3 (or TM4)} = \pm 11\mu\text{A}, \text{ and TM5 (or TM6)} = \pm 22\mu\text{A}.$$

As is the case with the FE signal, the TE signal is switched to pass through a low-pass filter formed by the internal resistance (100kΩ) and the capacitance connected to Pin 45.

The ISET pin is used to connect external resistance. This external resistance sets the current which determines the focus search, track jump, and sled kick levels.

- Focus search current

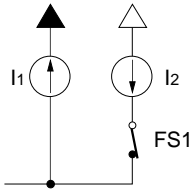

$$I_1 = \frac{V_{BG}}{R} \times \frac{1}{2} \quad (V_{BG}: \text{approximately } 1.27V)$$

$$I_2 = 2I_1$$

- Track jump current (TM3 and TM4 current)

$$I = \frac{V_{BG}}{R} \times \frac{1}{2}$$

- Sled kick current (TM5 and TM6 current, when D1 = D0 = 0 during 1X\$ commands)

$$I = \frac{V_{BG}}{R}$$

Use external resistance of between 30kΩ and 240kΩ.

Using external resistance outside this range may cause oscillation.

Focus OK Circuit

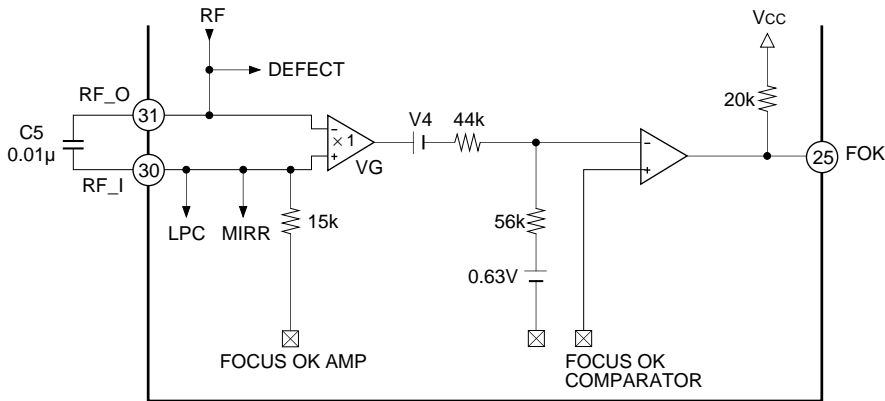

The focus OK circuit creates the timing window okaying the focus servo from the focus search state. The HPF output is obtained at Pin 30 from Pin 31 (RF signal), and the LPF output (opposite phase) of the focus OK amplifier output is also obtained.

V4 is set in $V3=V4$ to cancel V3 of the RF amplifier voltage V_{RFO} .

The focus OK output is inverted when $V_{RFI} - V_{RFO} \approx -0.51V$.

Note that, C5 determines the time constant of the HPF for the mirror circuit and the LPF of the focus OK amplifier. Ordinarily, with a C5 equal to $0.01\mu F$ selected, the f_c is equal to 1kHz, and block error rate degradation brought about by RF envelope defects caused by scratched discs can be prevented.

Defect circuit

After differentiated with the capacitance coupling and then inverted, the RF_O signal is bottom held by means of the long and short time constants.

The short time-constant bottom hold responds to a disc mirror defect in excess of 0.1ms.

The long time-constant bottom hold keeps the mirror level prior to the defect and shifts the level.

The long and short time-constant signals are compared to generate the mirror defect detection signal.

Be sure to disable DFCT (\$34X) during focus search because the focus drive waveform is muted.

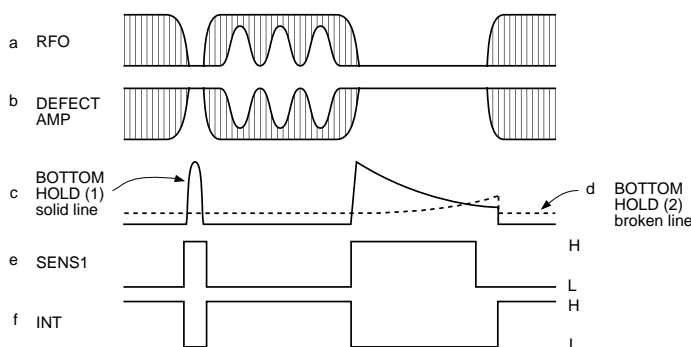
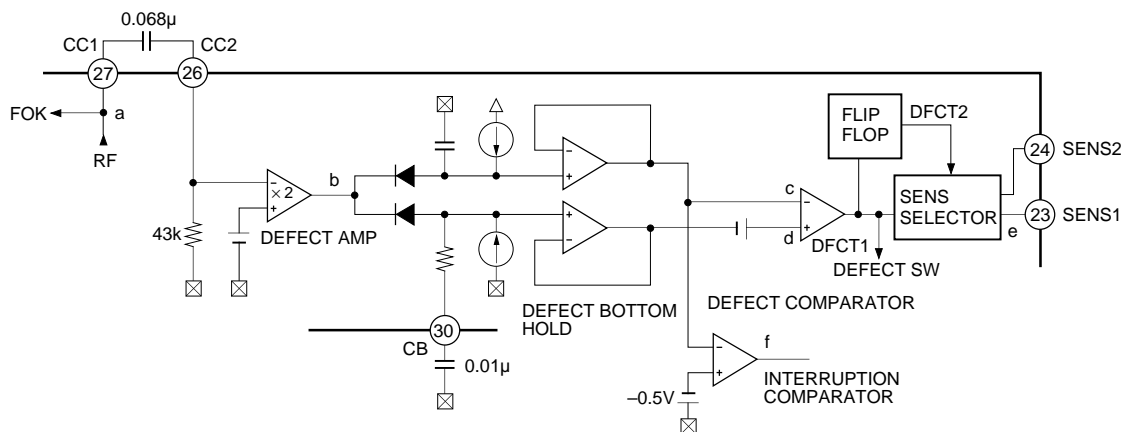

Mirror Circuit

The mirror circuit performs peak and bottom hold after the RFI signal has been inverting amplified. For the peak hold, a time constant can follow a 30kHz traverse, and, for the bottom hold, one can follow the rotation cycle envelope fluctuation.

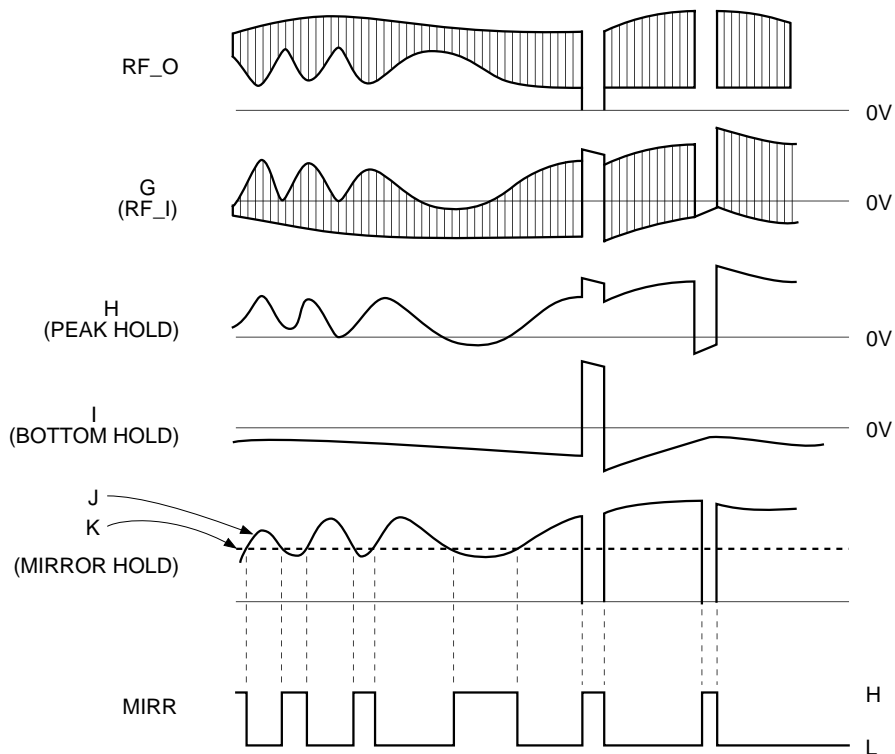
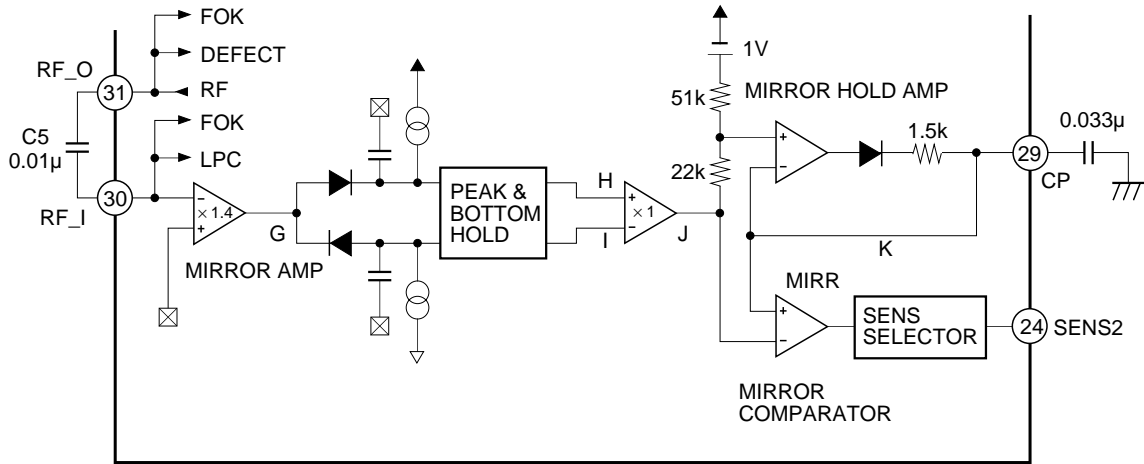

The DC restored-envelope signal J is obtained by amplifying the difference between the peak and bottom hold signals H and I. Signal J has a large time constant of 2/3 its peak value, and the mirror output is obtained by comparing it to the peak hold signal K. If the value of C5 is made smaller, the low frequency component of the RF signal is cut off and the amplification of the signal G gets small. Then, that of the signal J gets also small and the signal K level becomes low, resulting in the short mirror output pulse width. Accordingly, when on the disc track, the mirror output is Low; when between tracks (mirrored portion), it is High; and when a defect is detected, it is High. The mirror hold time constant must be sufficiently large compared with the traverse signal.

SENS Selector

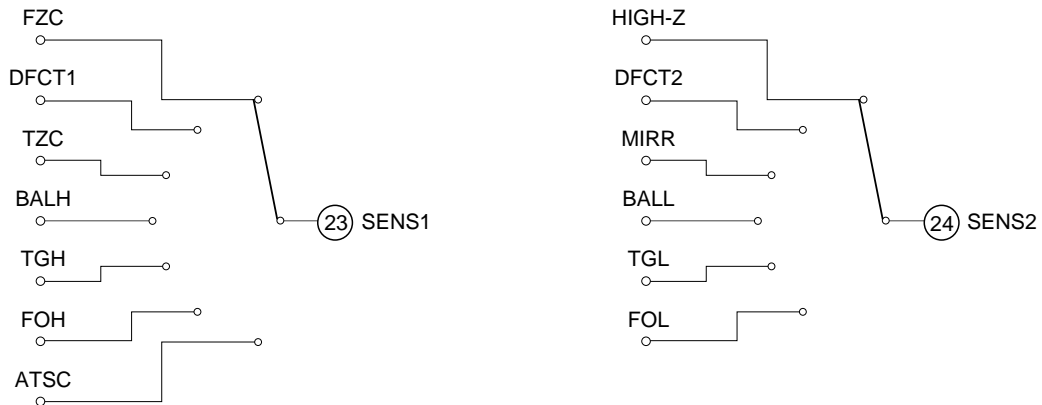

What is output to the SENS1 and SENS2 pins varies according to the address input to the DATA pin.

DATA (Pin 20) 8-bit transfer								SENS1	SENS2
ADDRESS				DATA					
D7	D6	D5	D4	D3	D2	D1	D0		
0	0	0	0	X	X	X	X	FZC	H (HIGH-Z)
0	0	0	1	X	X	X	X	DFCT1	DFCT2
0	0	1	0	X	X	X	X	TZC	MIRR
0	1	0	0	X	X	X	X	H (HIGH-Z)	H (HIGH-Z)
1	1	1	1	X	X	X	X		

DATA (Pin 20) 12-bit transfer												SENS1	SENS2
ADDRESS						DATA							
D11	D10	D9	D8	D7	D6	D5	D4	D3	D2	D1	D0		
0	0	1	1	0	0	X	X	X	X	X	X	BALH	BALL
0	0	1	1	0	1	X	X	X	X	X	X	TGH	TGL
0	0	1	1	1	0	X	X	X	X	X	X	FOH	FOL
0	0	1	1	1	1	X	X	X	X	X	X	ATSC	H (HIGH-Z)

Notes)

- 12-bit transfer should be performed during \$3XX commands. When 8 bits are transferred, SENS1 and SENS2 are switched according to the D3 and D2 data.
- SENS1 and SENS2 are switched without latching.

Commands

The input data to operate this IC is configured as 8-bit/12-bit data; however, below, this input data is represented by 2-digit hexadecimal numerals in the form \$XX, where X is a hexadecimal numeral between 0 and F/\$XXX for 12-bit.

Commands for the CXA2542AR can be broadly divided into four groups ranging in value from \$0X, \$1X, \$2X, \$3XX.

1. \$0X (FZC at SENS1 pin (Pin 23), H (Hi-Z) at SENS2 pin (Pin 24))

These commands are related to the focus servo control.
The bit configuration is as shown below.

D7	D6	D5	D4	D3	D2	D1	D0
0	0	0	0	FS4	—	FS2	FS1

Four focus related switches exist: FS1, FS2, FS4 and DFCT.

- \$00 When FS1 = 0, Pin 7 is charged to $(22\mu\text{A} - 11\mu\text{A}) \times 50\text{k}\Omega = 0.55\text{V}$.
If, in addition, FS2 = 0, this voltage is no longer transferred, and the output at Pin 5 becomes 0V.
- \$02 From the state described above, the only FS2 becomes 1. When this occurs, a negative signal is output to Pin 5. This voltage level is obtained by equation 1 below.

$$(22\mu\text{A} - 11\mu\text{A}) \times 50\text{k}\Omega \times \frac{\text{resistance between Pins 5 and 6}}{50\text{k}\Omega} \dots \text{Equation 1}$$

The SRCH DOWN speed can be increased by the charge up circuit.

- \$03 From the state described above, FS1 becomes 1, and a current source of +22μA is split off.
Then, a CR charge/discharge circuit is formed, and the voltage at Pin 7 decreases with the time as shown in Fig. 1 below.

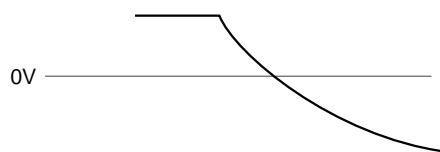

Fig. 1. Voltage at Pin 7 when FS1 goes from 0 → 1

This time constant is obtained with the 50kΩ resistance and an external capacitor.

By alternating the commands between \$02 and \$03, the focus search voltage can be constructed. (Fig. 2)

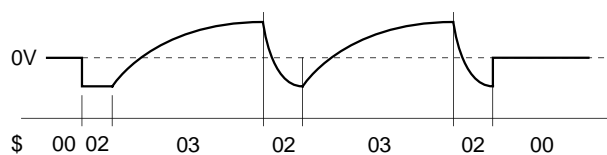

Fig. 2. Constructing the search voltage by alternating between \$02 and \$03. (Voltage at Pin 5)

1-1. FS4

This switch is provided between the focus error input and the focus phase compensation, and is in charge of turning the focus servo ON and OFF.

\$00 → \$08
 Focus off Focus on

1-2. Procedure of focus activation

For description, suppose that the polarity is as described below.

- a) The lens is searching the disc from far to near;
- b) The output voltage (Pin 5) is changing from negative to positive; and
- c) The focus S-curve is varying as shown below.

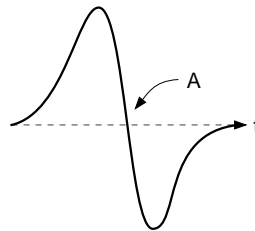

Fig. 3. S-curve

The focus servo is activated at the operating point indicated by A in Fig. 3. Ordinarily, focus searching and turning the focus servo switch ON are performed while the focus S-curve transits the point A indicated in Fig. 3. To prevent misoperation, this signal is ANDed with the focus OK signal.

In this IC, the FZC (Focus Zero Cross) signal is output from the SENS1 pin (Pin 23) as the point A transit signal. In addition, focus OK is output as a signal indicating that the signal is in focus (can be in focus in this case).

Following the line of the above description, focusing can be well obtained by observing the following timing chart.

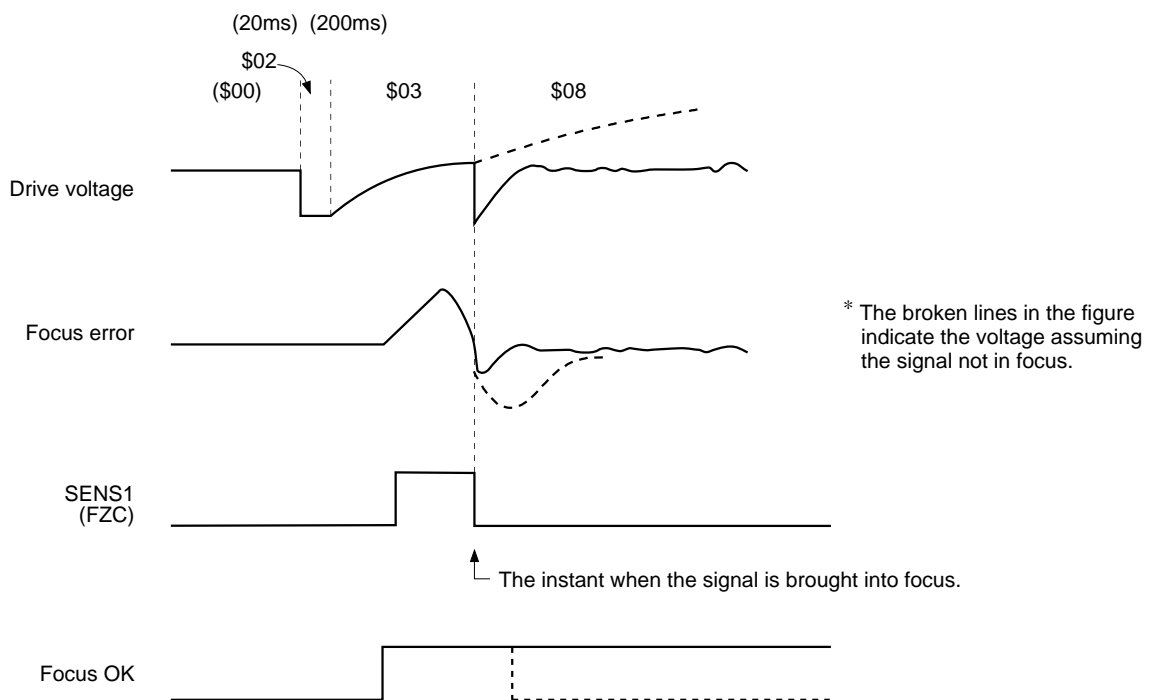

Fig. 4. Focus ON timing chart

Note that the time from the High to Low transition of FZC to the time command \$08 is asserted must be minimized. To do this, the software sequence shown in B is better than the sequence shown in A.

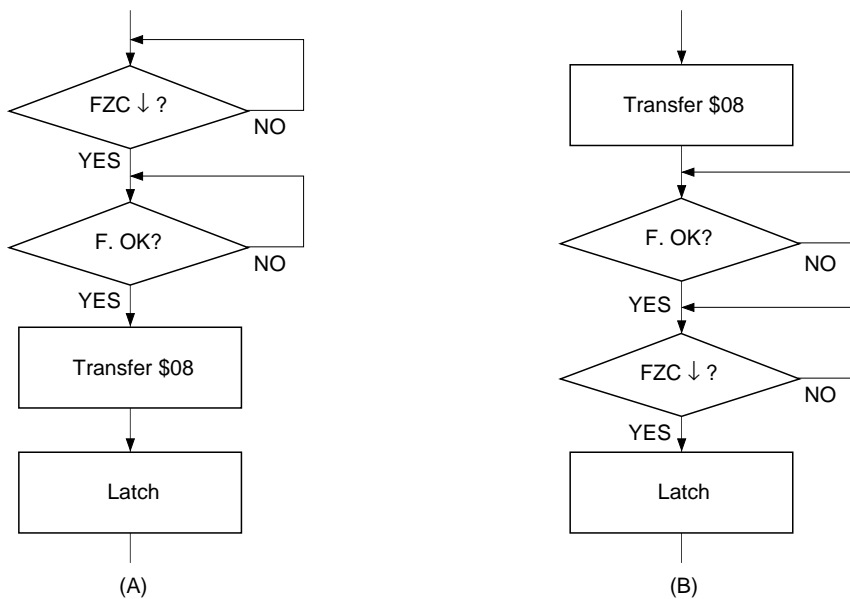

Fig. 5. Poor and good software command sequences

2. \$1X (DFCT1 at SENS1 pin (Pin 23), DFCT2 at SENS2 pin (Pin 24))

These commands deal with switching TG1/TG2, brake circuit ON/OFF, and the sled kick output.

The bit configuration is as follows:

D7	D6	D5	D4	D3	D2	D1	D0
0	0	0	1	TG1, TG2	Brake	Sled kick	
				ON/OFF	circuit	level	
				ON/OFF	ON/OFF		

Sled kick level		Relative value
D1 (PS1)	D0 (PS0)	
0	0	±1
0	1	±2
1	0	±3
1	1	±4

TG1, TG2, TM7

The purpose of TG1 and TG2 is to switch the tracking servo gain Up/Normal. TG1 and TG2 are interlinked switches. The brake circuit (TM7) is to prevent the frequently occurred phenomena where the merely 10-track jump has been performed actually though a 100-track jump was intended to be done due to the extremely degraded actuator settling caused by the servo motor exceeding the linear range after a 100 or 10-track jump. For the prevention method, when the actuator travels radially; that is, when it traverses from the inner track to the outer track of the disc and vice versa, the brake circuit utilizes the fact that the phase relationship between the RF envelope and the tracking error is 180° out-of-phase to cut the unneeded portion of the tracking error and apply braking.

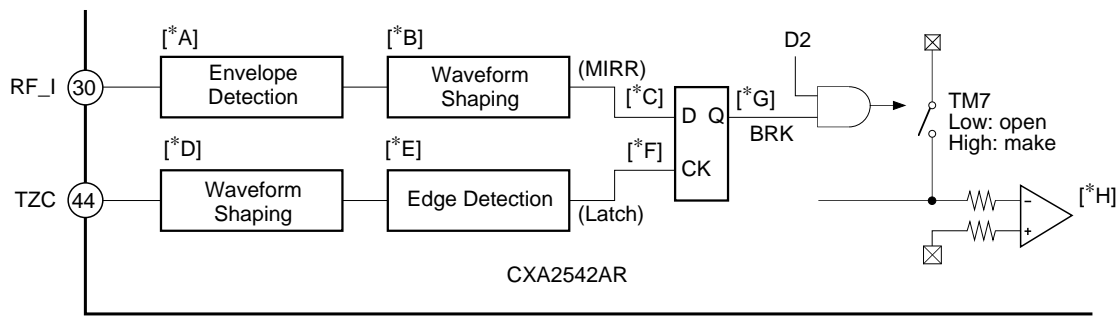

Fig. 6. TM7 movement during braking operation

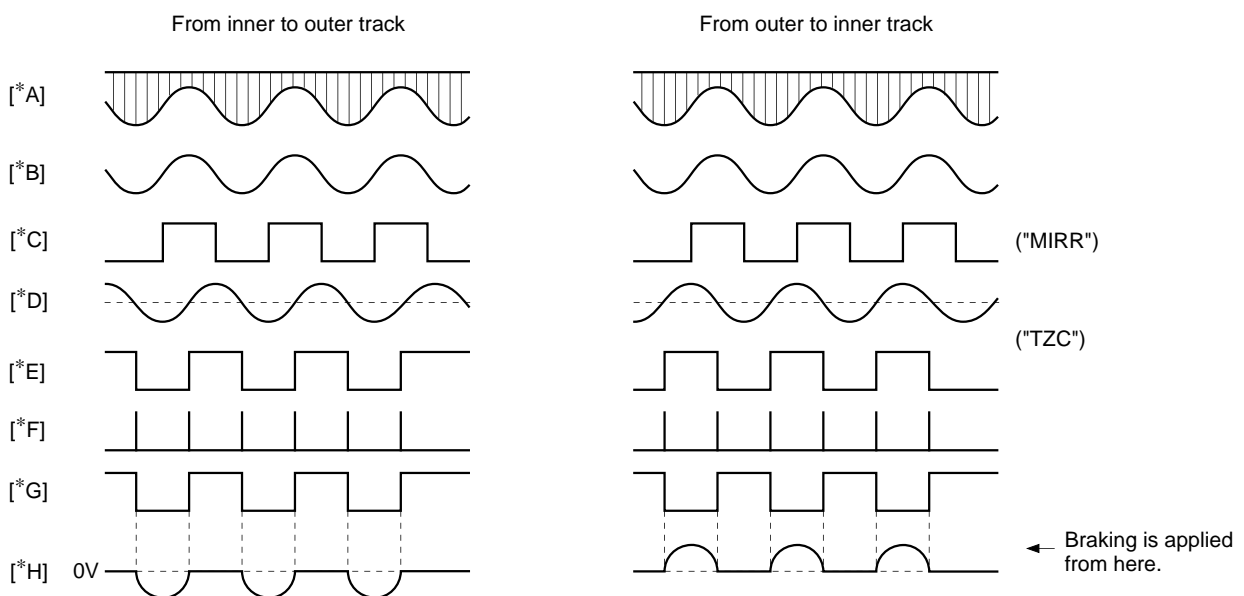

Fig. 7. Internal waveform

3. \$2X (TZC at SENS1 pin (Pin 23), MIRR at SENS2 pin (Pin 24))

These commands deal with turning the tracking servo and sled servo ON/OFF, and creating the jump pulse and fast forward pulse during access operations.

D7	D6	D5	D4	D3 D2		D1 D0	
0	0	1	0	Tracking control		Sled control	
				00	off	00	off
				01	Servo ON	01	Servo ON
				10	F-JUMP	10	F-FAST FORWARD
				11	R-JUMP	11	R-FAST FORWARD
				↓		↓	
				TM1, TM3, TM4,		TM2, TM5, TM6	

4. \$3XX

These commands mainly control the balance and gain control circuit switches used during automatic tracking adjustment and the bias circuit switch used during automatic focus bias adjustment.

In the initial resetting state, BAL1 to BAL4 switches and TOG1 to TOG4 switches are ON. Also, the IFB1 to IFB6 switches are ON.

• Balance adjustment

The balance adjustment switches BAL1 to BAL4 can be controlled by setting D6 = 0 and D7 = 0. The switches are set using D0 to D3.

At this time, SENS1 outputs BALH and SENS2 outputs BALL.

Data is set by specifying switch conditions D0 to D3 and sending a latch pulse with D6 = 0 and D7 = 0.

Sending a latch pulse with D6, D7 ≠ 0 does not change the balance switch settings.

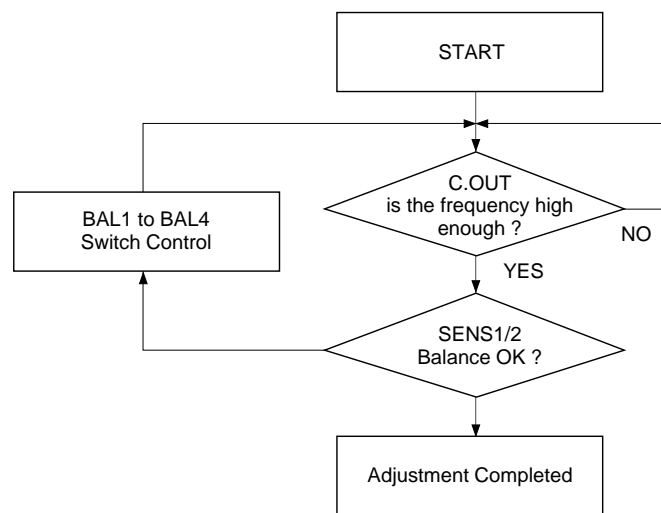

Balance adjustment

• Gain adjustment

The gain adjustment switches TOG1 to TOG4 can be controlled by setting D6 = 1 and D7 = 0. These switches are set using D0 to D3.

At this time, SENS1 outputs TGH and SENS2 outputs TGL.

In a fashion similar to the method used with the balance adjustment, set the data by specifying switch conditions D0 to D3 and sending a latch pulse with D6 = 1 and D7 = 0.

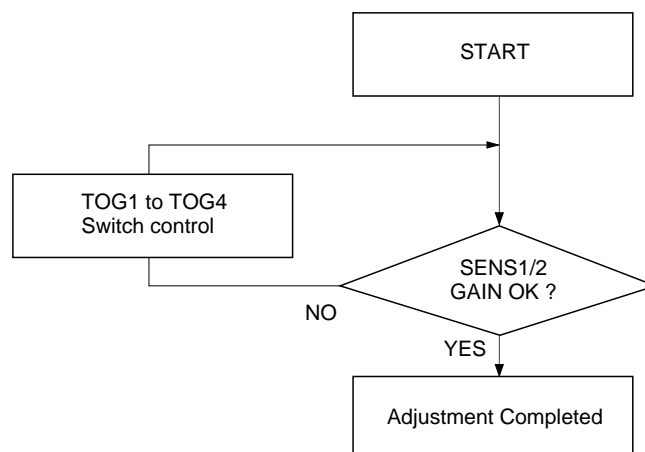

Gain adjustment

• Focus bias adjustment

The focus bias adjustment switches IFB1 to IFB6 can be controlled by setting D6 = 0 and D7 = 1. The switches are set using D0 to D5.

At this time, SENS1 outputs FOH and SENS2 outputs FOL.

Data is set by specifying switch conditions D0 to D5 and sending a latch pulse with D6 = 0 and D7 = 1.

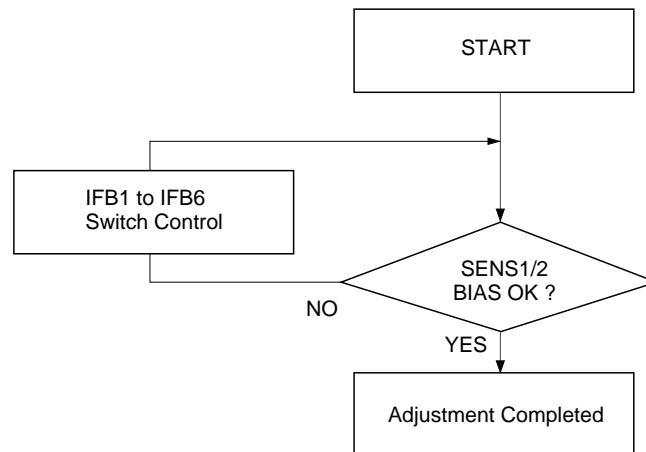

Focus bias adjustment method

• TGFL

The tracking gain can be switched by setting D5 with D6 = 1 and D7 = 0.

The tracking gain is GAIN UP with D5 = 1 and NORMAL GAIN with D5 = 0.

The TEO signal level can be made higher by approximately 6dB for GAIN UP.

When the TEO signal level is low and TGH (SENS1 pin) does not go Low during tracking adjustment, the gain should be raised with the TGFL command for adjustment.

• LPC

The laser power control circuit can be turned ON and OFF by setting D0 with D6 = 1 and D7 = 1.

The circuit is ON with D0 = 1 and OFF with D0 = 0.

• LPCL

The laser power control limit can be switched between $\pm 30\%$ and $\pm 50\%$ by setting D1 with D6 = 1 and D7 = 1.

The control limit is $\pm 30\%$ with D1 = 0 and $\pm 50\%$ with D1 = 1.

• LDON

The laser diode can be turned ON and OFF by setting D2 with D6 = 1 and D7 = 1.

The laser diode is ON with D2 = 1 and OFF with D2 = 0.

- ATSC

The anti-shock function can be controlled by setting D3 with D6 = 1 and D7 = 1.

This function is disabled with D3 = 1 and enabled with D3 = 0.

At this time, SENS1 outputs ATSC.

Even if ATSC is disabled, ATSC is output to SENS1.

When an anti-shock signal is generated during the enable status, TG1 and TG2 switch to GAIN UP mode.

(In the Block Diagram, TG1 is set to the ○ side and TG2 is OFF. Even if TG1 and TG2 are in NORMAL mode, they switch to GAIN UP mode in conjunction with ATSC.)

When the anti-shock function is not used, Pin 43 (ATSC) should be connected to VC.

- RDFCT2

DFCT2 can be reset by setting D4 with D6 = 1 and D7 = 1.

DFCT2 is reset with D4 = 1.

After a reset, High is held when DFCT1 rises.

During \$1X commands, DFCT2 is output from SENS2.

DFCT2 operates even if DFCT is disabled.

Whether or not DFCT rises at the proper timing for the microcomputer can also be confirmed.

- INT

The interruption (scratched disc) countermeasure circuit can be set to the operating status by setting D5 with D6 = 1 and D7 = 1.

This circuit is enabled when D5 = 1 and disabled when D5 = 0.

Even if DFCT1 does not rise, this circuit is effective for scratched discs which cause MIRR to rise.

When MIRR rises, the DFCT switch is routed through the low-pass filter.

The interruption countermeasure circuit is forcibly turned OFF regardless of the command when the tracking gain is increased. (including when the gain is increased by ATSC)

Even if DFCT is disabled, the interruption countermeasure circuit operates when INT is enabled.

CPU Serial Interface Timing Chart

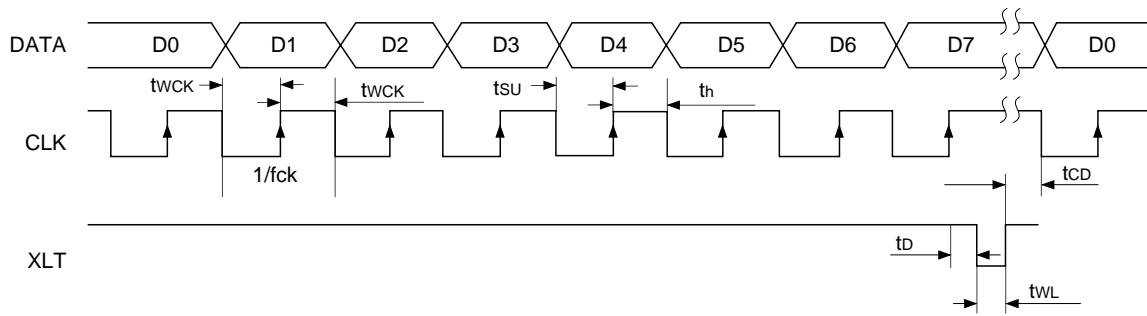

($V_{CC} = 3.0V$)

Item	Symbol	Min.	Typ.	Max.	Unit
Clock frequency	fck			1	MHz
Clock pulse width	fwck	500			ns
Setup time	tsu	500			ns
Hold time	th	500			ns
Delay time	td	500			ns
Latch pulse width	twL	1000			ns
Data transfer interval	tCD	1000			ns
Low level input voltage	VIL	0.0		$(V_{CC} - V_{EE}) \times 0.1$	V
High level input voltage	VIH	$(V_{CC} - V_{EE}) \times 0.9$		VCC	V

System Control

Item	DATA (Pin 20) 8-bit transfer								SENS1	SENS2	
	ADDRESS				DATA						
	D7	D6	D5	D4	D3	D2	D1	D0			
FOCUS CONTROL	0	0	0	0	FS4 Focus 1 = ON 0 = OFF	—	FS2 SRCH ON 1 = ON 0 = OFF	FS2 SRCH UP 1 = UP 0 = DOWN	FZC	H (HIGH-Z)	
TRACKING CONTROL	0	0	0	1	TG1, TG2 1 = GAIN UP 0 = NORMAL	BRAKE 1 = ENABLE 0 = DISABLE	SLED KICK + 2	SLED KICK + 1	DFCT1	DFCT2	
TRACKING SLED MODE	0	0	1	0	TRACKING MODE *1			SLED MODE *2		TZC	MIRR

*1 TRACKING MODE

	D3	D2
OFF	0	0
ON	0	1
FWD JUMP	1	0
REV JUMP	1	1

*2 SLED MODE

	D1	D0
OFF	0	0
ON	0	1
FWD MOVE	1	0
REV MOVE	1	1

Item	DATA (Pin 20) 12-bit transfer												SENS1	SENS2
	ADDRESS			DATA										
	D11	D10	D9	D8	D7	D6	D5	D4	D3	D2	D1	D0		
E-F BALANCE	0	0	1	1	0	0	DFCT 1 = DISABLE 0 = ENABLE	—	BAL4 1 = OFF 0 = ON	BAL3 1 = OFF 0 = ON	BAL2 1 = OFF 0 = ON	BAL1 1 = OFF 0 = ON	BALH	BALL
TRACKING GAIN	0	0	1	1	0	1	TGFL 1 = GAIN UP 0 = NORMAL	—	TOG4 1 = OFF 0 = ON	TOG3 1 = OFF 0 = ON	TOG2 1 = OFF 0 = ON	TOG1 1 = OFF 0 = ON	TGH	TGL
FOCUS BIAS	0	0	1	1	1	0	IFB6 1 = OFF 0 = ON	IFB5 1 = OFF 0 = ON	IFB4 1 = OFF 0 = ON	IFB3 1 = OFF 0 = ON	IFB2 1 = OFF 0 = ON	IFB1 1 = OFF 0 = ON	FOH	FOL
Others	0	0	1	1	1	1	INT 1 = ENABLE 0 = DISABLE	RDFCT2 1 = RESET 0 = NORMAL	ATSC	LDON	LPCL 1 = ±50% 0 = ±30%	LPC	ATSC	H (HIGH-Z)

Notes)

- When ATSC is enabled, even if TG1 and TG2 are in NORMAL mode, TG1 and TG2 switch to GAIN UP mode in conjunction with ATSC.
- INT is forcibly disabled regardless of the command when the tracking gain is increased. (including when the gain is increased by ATSC)

When reset

- SENS1 = FZC
- SENS2 = High (Hi-Z)
- RDFCT2 = 1 (Reset)
- IFB1 to IFB6 = 0 (switch ON)
- TOG1 to TOG4 = 0 (switch ON)
- BAL1 to BAL4 = 1 (switch ON)
- Other data is "0".

Serial Data Truth Table

Serial Data	HEX	Functions			
		FS4		FS2	FS1
FOCUS CONTROL					
0000 0000	\$00	0		0	0
0000 0001	\$01	0		0	1
0000 0010	\$02	0		1	0
0000 0011	\$03	0		1	1
0000 0100	\$04	0		0	0
0000 0101	\$05	0		0	1
0000 0110	\$06	0		1	0
0000 0111	\$07	0		1	1
0000 1000	\$08	1		0	0
0000 1001	\$09	1		0	1
0000 1010	\$0A	1		1	0
0000 1011	\$0B	1		1	1
0000 1100	\$0C	1		0	0
0000 1101	\$0D	1		0	1
0000 1110	\$0E	1		1	0
0000 1111	\$0F	1		1	1
TRACKING CONTROL					
			BRAK	SLD KICK	
		TG1	Fig. 6 D2	KICK	KICK
		TG2		+2	+1
0001 0000	\$10	0	0	0	0
0001 0001	\$11	0	0	0	1
0001 0010	\$12	0	0	1	0
0001 0011	\$13	0	0	1	1
0001 0100	\$14	0	1	0	0
0001 0101	\$15	0	1	0	1
0001 0110	\$16	0	1	1	0
0001 0111	\$17	0	1	1	1
0001 1000	\$18	1	0	0	0
0001 1001	\$19	1	0	0	1
0001 1010	\$1A	1	0	1	0
0001 1011	\$1B	1	0	1	1
0001 1100	\$1C	1	1	0	0
0001 1101	\$1D	1	1	0	1
0001 1110	\$1E	1	1	1	0
0001 1111	\$1F	1	1	1	1

Notes) • FS1
1: OFF
0: ON

• FS2
1: ON
0: OFF

• FS4
In the Block Diagram:
1: SW ○ side
0: SW ● side

Notes) • TG1
In the Block Diagram:
1: SW ○ side
0: SW ● side

• TG2
1: OFF
0: ON

• BRAKE
When D2 in Fig. 6 is:
1: 1
0: 0

• Sled kick level

D1	D0	Relative value
0	0	±1
0	1	±2
1	0	±3
1	1	±4

Serial Data	HEX	Function					
		TM6	TM5	TM4	TM3	TM2	TM1
TRACKING/SLED MODE							
0010 0000	\$20	0	0	0	0	0	0
0010 0001	\$21	0	0	0	0	1	0
0010 0010	\$22	0	1	0	0	0	0
0010 0011	\$23	1	0	0	0	0	0
0010 0100	\$24	0	0	0	0	0	1
0010 0101	\$25	0	0	0	0	1	1
0010 0110	\$26	0	1	0	0	0	1
0010 0111	\$27	1	0	0	0	0	1
0010 1000	\$28	0	0	0	1	0	0
0010 1001	\$29	0	0	0	1	1	0
0010 1010	\$2A	0	1	0	1	0	0
0010 1011	\$2B	1	0	0	1	0	0
0010 1100	\$2C	0	0	1	0	0	0
0010 1101	\$2D	0	0	1	0	1	0
0010 1110	\$2E	0	1	1	0	0	0
0010 1111	\$2F	1	0	1	0	0	0

- Notes)** • TM1/TM2
 In the Block Diagram:
 1: SW ○ side
 0: SW ● side
- TM3/TM4/TM5/TM6
 1: ON
 0: OFF

Serial Data \$3XX	HEX	BAL SW				TOG SW	TGFL	IFB SW					INT	RDF CT2	ATSC	LDON	LPCL	LPC	DFCT
		4	3	2	1			4	3	2	1	6							
0011 0011 0000	\$330	1	1	1	1	---	---	---	---	---	---	---	---	---	---	---	---	---	D
0011 0011 0001	\$331	1	1	1	0	---	---	---	---	---	---	---	---	---	---	---	---	---	D
0011 0011 0010	\$332	1	1	0	1	---	---	---	---	---	---	---	---	---	---	---	---	---	D
0011 0011 0011	\$333	1	1	0	0	---	---	---	---	---	---	---	---	---	---	---	---	---	D
0011 0011 0100	\$334	1	0	1	1	---	---	---	---	---	---	---	---	---	---	---	---	---	D
0011 0011 0101	\$335	1	0	1	0	---	---	---	---	---	---	---	---	---	---	---	---	---	D
0011 0011 0110	\$336	1	0	0	1	---	---	---	---	---	---	---	---	---	---	---	---	---	D
0011 0011 0111	\$337	1	0	0	0	---	---	---	---	---	---	---	---	---	---	---	---	---	D
0011 0011 1000	\$338	0	1	1	1	---	---	---	---	---	---	---	---	---	---	---	---	---	D
0011 0011 1001	\$339	0	1	1	0	---	---	---	---	---	---	---	---	---	---	---	---	---	D
0011 0011 1010	\$33A	0	1	0	1	---	---	---	---	---	---	---	---	---	---	---	---	---	D
0011 0011 1011	\$33B	0	1	0	0	---	---	---	---	---	---	---	---	---	---	---	---	---	D
0011 0011 1100	\$33C	0	0	1	1	---	---	---	---	---	---	---	---	---	---	---	---	---	D
0011 0011 1101	\$33D	0	0	1	0	---	---	---	---	---	---	---	---	---	---	---	---	---	D
0011 0011 1110	\$33E	0	0	0	1	---	---	---	---	---	---	---	---	---	---	---	---	---	D
0011 0011 1111	\$33F	0	0	0	0	---	---	---	---	---	---	---	---	---	---	---	---	---	D
0011 0100 0000	\$340	---	---	---	---	1	1	1	1	0	---	---	---	---	---	---	---	---	---
0011 0100 0001	\$341	---	---	---	---	1	1	1	0	0	---	---	---	---	---	---	---	---	---
0011 0100 0010	\$342	---	---	---	---	1	1	0	1	0	---	---	---	---	---	---	---	---	---
0011 0100 0011	\$343	---	---	---	---	1	1	0	0	0	---	---	---	---	---	---	---	---	---
0011 0100 0100	\$344	---	---	---	---	1	0	1	1	0	---	---	---	---	---	---	---	---	---
0011 0100 0101	\$345	---	---	---	---	1	0	1	0	0	---	---	---	---	---	---	---	---	---
0011 0100 0110	\$346	---	---	---	---	1	0	0	1	0	---	---	---	---	---	---	---	---	---
0011 0100 0111	\$347	---	---	---	---	1	0	0	0	0	---	---	---	---	---	---	---	---	---
0011 0100 1000	\$348	---	---	---	---	0	1	1	1	0	---	---	---	---	---	---	---	---	---
0011 0100 1001	\$349	---	---	---	---	0	1	1	0	0	---	---	---	---	---	---	---	---	---
0011 0100 1010	\$34A	---	---	---	---	0	1	0	1	0	---	---	---	---	---	---	---	---	---
0011 0100 1011	\$34B	---	---	---	---	0	1	0	0	0	---	---	---	---	---	---	---	---	---
0011 0100 1100	\$34C	---	---	---	---	0	0	1	1	0	---	---	---	---	---	---	---	---	---
0011 0100 1101	\$34D	---	---	---	---	0	0	1	0	0	---	---	---	---	---	---	---	---	---
0011 0100 1110	\$34E	---	---	---	---	0	0	0	1	0	---	---	---	---	---	---	---	---	---
0011 0100 1111	\$34F	---	---	---	---	0	0	0	0	0	---	---	---	---	---	---	---	---	---
0011 0101 0000	\$350	---	---	---	---	1	1	1	1	0	---	---	---	---	---	---	---	---	---
0011 0101 0001	\$351	---	---	---	---	1	1	1	0	0	---	---	---	---	---	---	---	---	---
0011 0101 0010	\$352	---	---	---	---	1	1	0	1	0	---	---	---	---	---	---	---	---	---
0011 0101 0011	\$353	---	---	---	---	1	1	0	0	0	---	---	---	---	---	---	---	---	---
0011 0101 0100	\$354	---	---	---	---	1	0	1	1	0	---	---	---	---	---	---	---	---	---
0011 0101 0101	\$355	---	---	---	---	1	0	1	0	0	---	---	---	---	---	---	---	---	---
0011 0101 0110	\$356	---	---	---	---	1	0	0	1	0	---	---	---	---	---	---	---	---	---
0011 0101 0111	\$357	---	---	---	---	1	0	0	0	0	---	---	---	---	---	---	---	---	---
0011 0101 1000	\$358	---	---	---	---	0	1	1	1	0	---	---	---	---	---	---	---	---	---
0011 0101 1001	\$359	---	---	---	---	0	1	1	0	0	---	---	---	---	---	---	---	---	---
0011 0101 1010	\$35A	---	---	---	---	0	1	0	1	0	---	---	---	---	---	---	---	---	---
0011 0101 1011	\$35B	---	---	---	---	0	1	0	0	0	---	---	---	---	---	---	---	---	---
0011 0101 1100	\$35C	---	---	---	---	0	0	1	1	0	---	---	---	---	---	---	---	---	---
0011 0101 1101	\$35D	---	---	---	---	0	0	1	0	0	---	---	---	---	---	---	---	---	---
0011 0101 1110	\$35E	---	---	---	---	0	0	0	1	0	---	---	---	---	---	---	---	---	---
0011 0101 1111	\$35F	---	---	---	---	0	0	0	0	0	---	---	---	---	---	---	---	---	---

Serial Data \$3XX	HEX	BAL SW				TOG SW	TGFL	IFB SW						INT	RDF CT2	ATSC	LDON	LPCL	LPC	DFCT
		4	3	2	1			4	3	2	1	6	5							
0011 1100 0000	\$3C0	---	---	---	---	---	---	---	---	---	---	---	---	0	0	E	0	0	0	---
0011 1100 0001	\$3C1	---	---	---	---	---	---	---	---	---	---	---	---	0	0	E	0	0	1	---
0011 1100 0010	\$3C2	---	---	---	---	---	---	---	---	---	---	---	---	0	0	E	0	1	0	---
0011 1100 0011	\$3C3	---	---	---	---	---	---	---	---	---	---	---	---	0	0	E	0	1	1	---
0011 1100 0100	\$3C4	---	---	---	---	---	---	---	---	---	---	---	---	0	0	E	1	0	0	---
0011 1100 0101	\$3C5	---	---	---	---	---	---	---	---	---	---	---	---	0	0	E	1	0	1	---
0011 1100 0110	\$3C6	---	---	---	---	---	---	---	---	---	---	---	---	0	0	E	1	1	0	---
0011 1100 0111	\$3C7	---	---	---	---	---	---	---	---	---	---	---	---	0	0	E	1	1	1	---
0011 1100 1000	\$3C8	---	---	---	---	---	---	---	---	---	---	---	---	0	0	D	0	0	0	---
0011 1100 1001	\$3C9	---	---	---	---	---	---	---	---	---	---	---	---	0	0	D	0	0	1	---
0011 1100 1010	\$3CA	---	---	---	---	---	---	---	---	---	---	---	---	0	0	D	0	1	0	---
0011 1100 1011	\$3CB	---	---	---	---	---	---	---	---	---	---	---	---	0	0	D	0	1	1	---
0011 1100 1100	\$3CC	---	---	---	---	---	---	---	---	---	---	---	---	0	0	D	1	0	0	---
0011 1100 1101	\$3CD	---	---	---	---	---	---	---	---	---	---	---	---	0	0	D	1	0	1	---
0011 1100 1110	\$3CE	---	---	---	---	---	---	---	---	---	---	---	---	0	0	D	1	1	0	---
0011 1100 1111	\$3CF	---	---	---	---	---	---	---	---	---	---	---	---	0	0	D	1	1	1	---
0011 1101 0000	\$3D0	---	---	---	---	---	---	---	---	---	---	---	---	0	1	E	0	0	0	---
0011 1101 0001	\$3D1	---	---	---	---	---	---	---	---	---	---	---	---	0	1	E	0	0	1	---
0011 1101 0010	\$3D2	---	---	---	---	---	---	---	---	---	---	---	---	0	1	E	0	1	0	---
0011 1101 0011	\$3D3	---	---	---	---	---	---	---	---	---	---	---	---	0	1	E	0	1	1	---
0011 1101 0100	\$3D4	---	---	---	---	---	---	---	---	---	---	---	---	0	1	E	1	0	0	---
0011 1101 0101	\$3D5	---	---	---	---	---	---	---	---	---	---	---	---	0	1	E	1	0	1	---
0011 1101 0110	\$3D6	---	---	---	---	---	---	---	---	---	---	---	---	0	1	E	1	1	0	---
0011 1101 0111	\$3D7	---	---	---	---	---	---	---	---	---	---	---	---	0	1	E	1	1	1	---
0011 1101 1000	\$3D8	---	---	---	---	---	---	---	---	---	---	---	---	0	1	D	0	0	0	---
0011 1101 1001	\$3D9	---	---	---	---	---	---	---	---	---	---	---	---	0	1	D	0	0	1	---
0011 1101 1010	\$3DA	---	---	---	---	---	---	---	---	---	---	---	---	0	1	D	0	1	0	---
0011 1101 1011	\$3DB	---	---	---	---	---	---	---	---	---	---	---	---	0	1	D	0	1	1	---
0011 1101 1100	\$3DC	---	---	---	---	---	---	---	---	---	---	---	---	0	1	D	1	0	0	---
0011 1101 1101	\$3DD	---	---	---	---	---	---	---	---	---	---	---	---	0	1	D	1	0	1	---
0011 1101 1110	\$3DE	---	---	---	---	---	---	---	---	---	---	---	---	0	1	D	1	1	0	---
0011 1101 1111	\$3DF	---	---	---	---	---	---	---	---	---	---	---	---	0	1	D	1	1	1	---
0011 1110 0000	\$3E0	---	---	---	---	---	---	---	---	---	---	---	---	1	0	E	0	0	0	---
0011 1110 0001	\$3E1	---	---	---	---	---	---	---	---	---	---	---	---	1	0	E	0	0	1	---
0011 1110 0010	\$3E2	---	---	---	---	---	---	---	---	---	---	---	---	1	0	E	0	1	0	---
0011 1110 0011	\$3E3	---	---	---	---	---	---	---	---	---	---	---	---	1	0	E	0	1	1	---
0011 1110 0100	\$3E4	---	---	---	---	---	---	---	---	---	---	---	---	1	0	E	1	0	0	---
0011 1110 0101	\$3E5	---	---	---	---	---	---	---	---	---	---	---	---	1	0	E	1	0	1	---
0011 1110 0110	\$3E6	---	---	---	---	---	---	---	---	---	---	---	---	1	0	E	1	1	0	---
0011 1110 0111	\$3E7	---	---	---	---	---	---	---	---	---	---	---	---	1	0	E	1	1	1	---
0011 1110 1000	\$3E8	---	---	---	---	---	---	---	---	---	---	---	---	1	0	D	0	0	0	---
0011 1110 1001	\$3E9	---	---	---	---	---	---	---	---	---	---	---	---	1	0	D	0	0	1	---
0011 1110 1010	\$3EA	---	---	---	---	---	---	---	---	---	---	---	---	1	0	D	0	1	0	---
0011 1110 1011	\$3EB	---	---	---	---	---	---	---	---	---	---	---	---	1	0	D	0	1	1	---
0011 1110 1100	\$3EC	---	---	---	---	---	---	---	---	---	---	---	---	1	0	D	1	0	0	---
0011 1110 1101	\$3ED	---	---	---	---	---	---	---	---	---	---	---	---	1	0	D	1	0	1	---
0011 1110 1110	\$3EE	---	---	---	---	---	---	---	---	---	---	---	---	1	0	D	1	1	0	---
0011 1110 1111	\$3EF	---	---	---	---	---	---	---	---	---	---	---	---	1	0	D	1	1	1	---

Serial Data \$3XX	HEX	BAL SW				TOG SW	TGFL	IFB SW						INT	RDF CT2	ATSC	LDON	LPCL	LPC	DFCT
		4	3	2	1			4	3	2	1	6	5							
0011 1111 0000	\$3F0	—	—	—	—	—	—	—	—	—	—	—	—	1	1	E	0	0	0	—
0011 1111 0001	\$3F1	—	—	—	—	—	—	—	—	—	—	—	—	1	1	E	0	0	1	—
0011 1111 0010	\$3F2	—	—	—	—	—	—	—	—	—	—	—	—	1	1	E	0	1	0	—
0011 1111 0011	\$3F3	—	—	—	—	—	—	—	—	—	—	—	—	1	1	E	0	1	1	—
0011 1111 0100	\$3F4	—	—	—	—	—	—	—	—	—	—	—	—	1	1	E	1	0	0	—
0011 1111 0101	\$3F5	—	—	—	—	—	—	—	—	—	—	—	—	1	1	E	1	0	1	—
0011 1111 0110	\$3F6	—	—	—	—	—	—	—	—	—	—	—	—	1	1	E	1	1	0	—
0011 1111 0111	\$3F7	—	—	—	—	—	—	—	—	—	—	—	—	1	1	E	1	1	1	—
0011 1111 1000	\$3F8	—	—	—	—	—	—	—	—	—	—	—	—	1	1	D	0	0	0	—
0011 1111 1001	\$3F9	—	—	—	—	—	—	—	—	—	—	—	—	1	1	D	0	0	1	—
0011 1111 1010	\$3FA	—	—	—	—	—	—	—	—	—	—	—	—	1	1	D	0	1	0	—
0011 1111 1011	\$3FB	—	—	—	—	—	—	—	—	—	—	—	—	1	1	D	0	1	1	—
0011 1111 1100	\$3FC	—	—	—	—	—	—	—	—	—	—	—	—	1	1	D	1	0	0	—
0011 1111 1101	\$3FD	—	—	—	—	—	—	—	—	—	—	—	—	1	1	D	1	0	1	—
0011 1111 1110	\$3FE	—	—	—	—	—	—	—	—	—	—	—	—	1	1	D	1	1	0	—
0011 1111 1111	\$3FF	—	—	—	—	—	—	—	—	—	—	—	—	1	1	D	1	1	1	—

Notes) • 0 means OFF and 1 means ON for TOG SW and BAL SW. These are not equal to the setting values of each bit for serial data.

- "—" in the Truth Table indicates that the status does not change.

- TGFL

In the Block Diagram:

1: SW ○ side

0: SW ● side

- ATSC E: enable/D: disable
- DFCT E: enable/D: disable

Initial State (resetting state)

Item	ADDRESS				DATA				HEX
	D7	D6	D5	D4	D3	D2	D1	D0	
FOCUS CONTROL	0	0	0	0	0	0	0	0	\$00
TRACKING CONTROL	0	0	0	1	0	0	0	0	\$10
TRACKING SLED MODE	0	0	1	0	0	0	0	0	\$20

Item	ADDRESS						DATA						HEX
	D11	D10	D9	D8	D7	D6	D5	D4	D3	D2	D1	D0	
E-F BALANCE	0	0	1	1	0	0	0	0	0	0	0	0	\$300
TRACKING GAIN	0	0	1	1	0	1	0	0	0	0	0	0	\$340
FOCUS BIAS	0	0	1	1	1	0	0	0	0	0	0	0	\$380
Others	0	0	1	1	1	1	0	1	0	0	0	0	\$3D0

The above data means the following operation modes.

- FOCUS CONTROL : FOCUS OFF, FOCUS SEARCH OFF, FOCUS SEACH DOWN
- TRACKING CONTROL : TG1-TG2 NORMAL, BRAKE DISABLE, SLED KICK relative level value ± 1
- TRACKING SLED MODE : TRACKING OFF, SLED OFF
- E-F BALANCE : BAL1 to BAL4 = 0 (switch ON). DFCT ENABLE
- TRACKING GAIN : TOG1 to TOG4 = 0 (switch ON), TGFL NORMAL
- FOCUS BIAS : IFB1 to IFB6 = 0 (switch ON)
- Others : INT DISABLE, DFCT2 RESET, ATSC ENABLE, LDON OFF, LPCL $\pm 30\%$, LPC OFF

Notes on Operation

1. Focus OK circuit

- 1) Refer to the "Description of Operation" for the time constant setting of the focus OK amplifier LPF and the mirror amplifier HPF.
- 2) The equivalent circuit for the output pin (FOK) is shown in the diagram below.

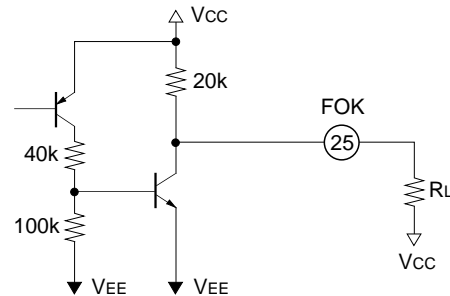

The FOK and comparator output are as follows:

- Output voltage High : $V_{FOKH} \approx \text{near } V_{CC}$
- Output voltage Low : $V_{FOKL} \approx V_{sat} (\text{NPN}) + V_{EE}$

2. Sled amplifier

The sled amplifier may oscillate when used by the buffer amplifier. Use with a gain of approximately 20dB.

3. Focus/Tracking internal phase compensation and reference design material

	Item	SD	Measurement pin	Conditions	Typ.	Unit
FCS	1.2kHz gain	08	6	$C_{FLB} = 0.1\mu F$ $C_{FGD} = 0.1\mu F$	21.5	dB
	1.2kHz phase	08			63	deg
TRK	1.2kHz gain	25	13	$C_{TGU} = 0.1\mu F$	13	dB
	1.2kHz phase	25			-125	deg
	2.7kHz gain	25 → 13			26.5	dB
	2.7kHz phase	25 → 13			-130	deg

4. Laser Poser Control

The RF level is stabilized by attaching an offset to the APC V_L and controlling the laser power in sync with the RF level fluctuations.

The laser life is shortened by increasing the laser power when the less light is reflected from the disc.

It is recommended that the typical laser power value is set lower to maintain the laser life.

Take care of the laser maximum ratings when using the laser power control circuit.

Package Outline

Unit: mm

48PIN LQFP (PLASTIC)

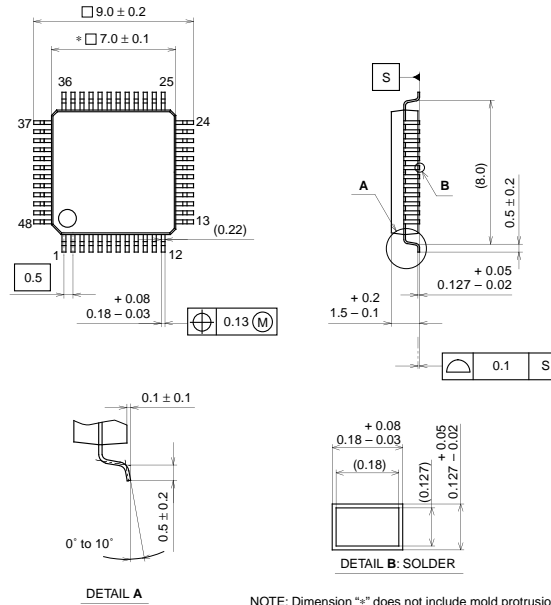

PACKAGE STRUCTURE

SONY CODE	LQFP-48P-L01
EIAJ CODE	P-LQFP48-7x7-0.5
JEDEC CODE	

PACKAGE MATERIAL	EPOXY RESIN
LEAD TREATMENT	SOLDER PLATING
LEAD MATERIAL	42/COPPER ALLOY
PACKAGE MASS	0.2g

48PIN LQFP (PLASTIC)

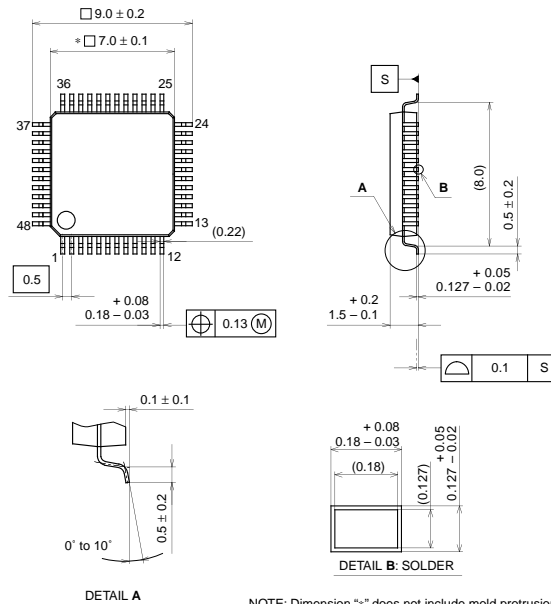

PACKAGE STRUCTURE

SONY CODE	LQFP-48P-L01
EIAJ CODE	P-LQFP48-7x7-0.5
JEDEC CODE	

PACKAGE MATERIAL	EPOXY RESIN
LEAD TREATMENT	SOLDER PLATING
LEAD MATERIAL	42/COPPER ALLOY
PACKAGE MASS	0.2g

LEAD PLATING SPECIFICATIONS

ITEM	SPEC.
LEAD MATERIAL	42 ALLOY
SOLDER COMPOSITION	Sn-Bi Bi:1-4wt%
PLATING THICKNESS	5-18 μ m



LittleDiode supplies new, hard to find or obsolete electronic components and semiconductors all over the world.

With over two million different components listed you are sure to find the part you need.

Feel free to visit us today at our online store:

LittleDiode.com

Looking forward to providing you with the best possible service.