

RF Amplifier for CD Player and CD-ROM

Description

The CXA2515AM/AN is an IC for RF signal processing of CD player and CD-ROM.

Features

- Wide-band RF amplifier. (RF signal $f_c \geq 12\text{MHz}$)
- RF equalizer (T type)
- EFM time constant can be adjusted (with switching function)
- APC (Automatic Power Control) function
- Power saving function
- Supports laser coupler

Functions

- RF summing amplifier
- RF equalizer
- Focus error amplifier
- Tracking error amplifier
- APC circuit

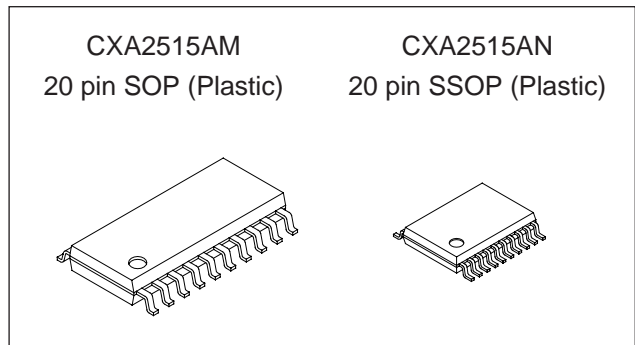

Absolute Maximum Ratings

- | | | | |
|-------------------------------|-----------|-------------|----|
| • Supply voltage | V_{CC} | 7 | V |
| • Storage temperature | T_{stg} | -65 to +150 | °C |
| • Allowable power dissipation | P_D | 500 | mW |

Operating Conditions

- | | | | |
|-------------------------|----------------|--------------|----|
| • Supply voltage | $V_{CC} - GND$ | +3.0 to +5.5 | V |
| • Operating temperature | T_{opr} | -20 to +75 | °C |

Applications

- CD players
- CD-ROM drives

Sony reserves the right to change products and specifications without prior notice. This information does not convey any license by any implication or otherwise under any patents or other right. Application circuits shown, if any, are typical examples illustrating the operation of the devices. Sony cannot assume responsibility for any problems arising out of the use of these circuits.

Block Diagram

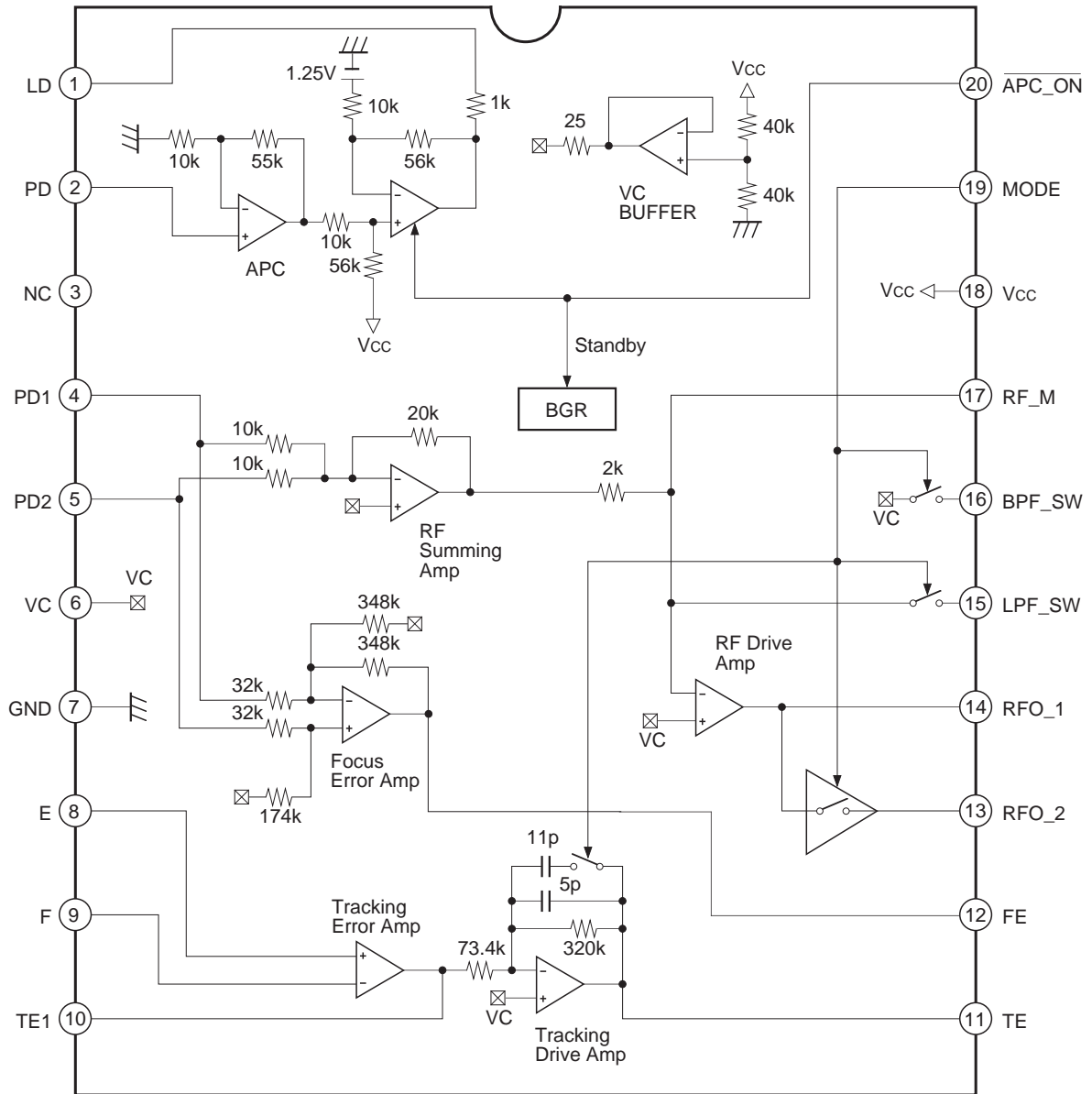

Pin Description

Pin No.	Symbol	I/O	Equivalent circuit	Description
1	LD	O		APC amplifier output.
2	PD	I		APC amplifier input.
3	NC			No connection.
4 5	PD1 PD2	I I		Input of RF summing amplifier and focus error amplifier.
6	VC	O		$(V_{cc} + GND) / 2$ DC voltage output.
7	GND			Ground.

Pin No.	Symbol	I/O	Equivalent circuit	Description
8 9 10 11	E F TE1 TE	I I O O		Tracking error amplifier input for Pins 8 and 9; tracking error amplifier output for Pin 10; tracking error drive output for Pin 11.
12	FE	O		Focus error amplifier output for Pin 12.
13	RFO_2	O		Buffer switch output which sets the RF signal time constant. OFF when Pin 19 is connected to Vcc, ON when it is connected to GND.
14 17	RFO_1 RF_M	O I		Non-inversion input of RF drive amplifier for Pin 17; RF signal output for Pin 14; resistance value connected between Pins 14 and 17 which determines the low frequency gain of RF drive amplifier.
15	LPF_SW	O		Transistor switch output which sets the LPF cut-off frequency of RF amplifier. OFF when Pin 19 is connected to Vcc, ON when it is connected to GND.

Pin No.	Symbol	I/O	Equivalent circuit	Description
16	BPF_SW	O		<p>Transistor switch output which sets the RF amplifier BPF boost. OFF when Pin 19 is connected to Vcc, ON when it is connected to GND.</p>
18	Vcc			Vcc.
19	MODE	I		<p>Multiple-speed mode switching input. Vcc : High multiple-speed mode GND: Low multiple-speed mode</p>
20	APC_ON	I		<p>APC amplifier ON/OFF switching. OFF when connecting to Vcc; ON when connecting to GND.</p>

(Ta = 25°C, VCC = 2.5V, GND = VC, VEE = -2.5V)

Electrical Characteristics

Measurement No.	Measurement item	Symbol	SW conditions				Bias conditions				Measurement point	Description of output waveform and measurement method	Min.	Typ.	Max.	Unit
			S1	S2	S3	S4	E1	E2	E3	E4						
1	Current consumption	Icc					0V	300mV	2.0V	-2.0V	18	Pin DC current measurement	-	6.3	12	mA
2	Current consumption	IEE						300mV		▶	7	Pin DC current measurement	-12	-6.3	-	mA
3	Standby current	Istb						300mV		2.0V	18	Pin DC current measurement	-	1.45	3	mA
4	Offset voltage	V1-1						0V		▶	14	Pin DC current measurement	-50	25	150	mV
5	Offset voltage	V1-2							-2.0V		13	Pin DC current measurement	-50	100	300	mV
6	Voltage gain	G1-1	○	○					2.0V		14	V1 = 100mVpp, f = 100kHz	16.5	20	23	dB
7	Voltage gain	G1-2	○	○					-2.0V		14	V1 = 100mVpp, f = 100kHz	16.5	20	23	dB
8	Voltage gain	G1-3	○	○					-2.0V		13	V1 = 100mVpp, f = 100kHz	16.5	20.3	23.3	dB
9	Frequency response	F1-1	○	○					2.0V		14	V1 = 100mVpp, f = 12MHz Difference for G1-1	-3	-	-	dB
10	Frequency response	F1-2	○	○					-2.0V		13	V1 = 100mVpp, f = 4MHz Difference for G1-2	-3	-	-	dB
11	Maximum output amplitude H	V1-2	○	○			300mV		2.0V		14	DC voltage measurement	1.3	2.3	-	V
12	Maximum output amplitude L	V1-3	○	○			-300mV				▶	DC voltage measurement	-	-1.3	-0.3	V
13	Offset voltage	V2-1					0V				12	DC voltage measurement	-50	0	50	mV
14	Voltage gain 1	G2-1	○									V1 = 100mVpp, f = 1kHz	17.7	20.7	23.7	dB
15	Voltage gain 2	G2-2		○								V1 = 100mVpp, f = 1kHz	17.7	20.7	23.7	dB
16	Voltage gain difference	G2-3										G2-1 to G2-2	-3	0	3	dB
17	Frequency response 1	F2-1	○									V1 = 100mVpp, f = 20kHz Difference for G2-1	-4	-	-	dB
18	Frequency response 2	F2-2		○								V1 = 100mVpp, f = 20kHz Difference for G2-2	-4	-	-	dB
19	Maximum output amplitude H	V2-2		○			300mV					DC voltage measurement	1.9	2.4	-	V
20	Maximum output amplitude L	V2-3		○			300mV					DC voltage measurement	-	-2.3	-1.9	V

Measurement No.	Measurement item	Symbol	SW conditions				Bias conditions				Measurement point	Description of output waveform and measurement method	Min.	Typ.	Max.	Unit
			S1	S2	S3	S4	E1	E2	E3	E4						
21	Offset voltage	V3-1					0V	0V	2.0V	-2.0V	11	DC voltage measurement	-50	0	50	mV
22	Voltage gain 1	G3-1										V1 = 100mVpp, f = 1kHz	17.9	20.9	23.9	dB
23	Voltage gain 2	G3-2										V1 = 100mVpp, f = 1kHz	17.9	20.9	23.9	dB
24	Voltage gain difference	G3-3										G3-1 to G3-2	-3	0	3	dB
25	Frequency response 1	F3-1										V1 = 100mVpp, f = 20kHz Difference for G3-1	-4	—	—	dB
26	Frequency response 2	F3-2										V1 = 100mVpp, f = 20kHz Difference for G3-2	-4	—	—	dB
27	Frequency response 3	F3-3										V1 = 100mVpp, f = 200kHz Difference for G3-1	-4	—	—	dB
28	Frequency response 4	F3-4										V1 = 100mVpp, f = 200kHz Difference for G3-2	-4	—	—	dB
29	Maximum output amplitude H	V3-2										DC voltage measurement	1.9	—	—	V
30	Maximum output amplitude L	V3-3										DC voltage measurement	—	—	-1.9	V
31	Offset voltage 1	V4-1										DC voltage measurement	—	-1.6	-0.1	V
32	Offset voltage 2	V4-2										DC voltage measurement	-1.2	0.1	1.6	V
33	Offset voltage 3	V4-3										DC voltage measurement	0.8	2.1	—	V
34	Offset voltage 4	V4-4										DC voltage measurement	1.8	2.45	—	V
35	Offset voltage 5	V4-5										I1 = 0.8mADC, DC voltage measurement	—	—	0	V
36	Offset voltage	V5-1										DC voltage measurement	-0.1	—	0.1	V

Electrical Characteristics Measurement Circuit

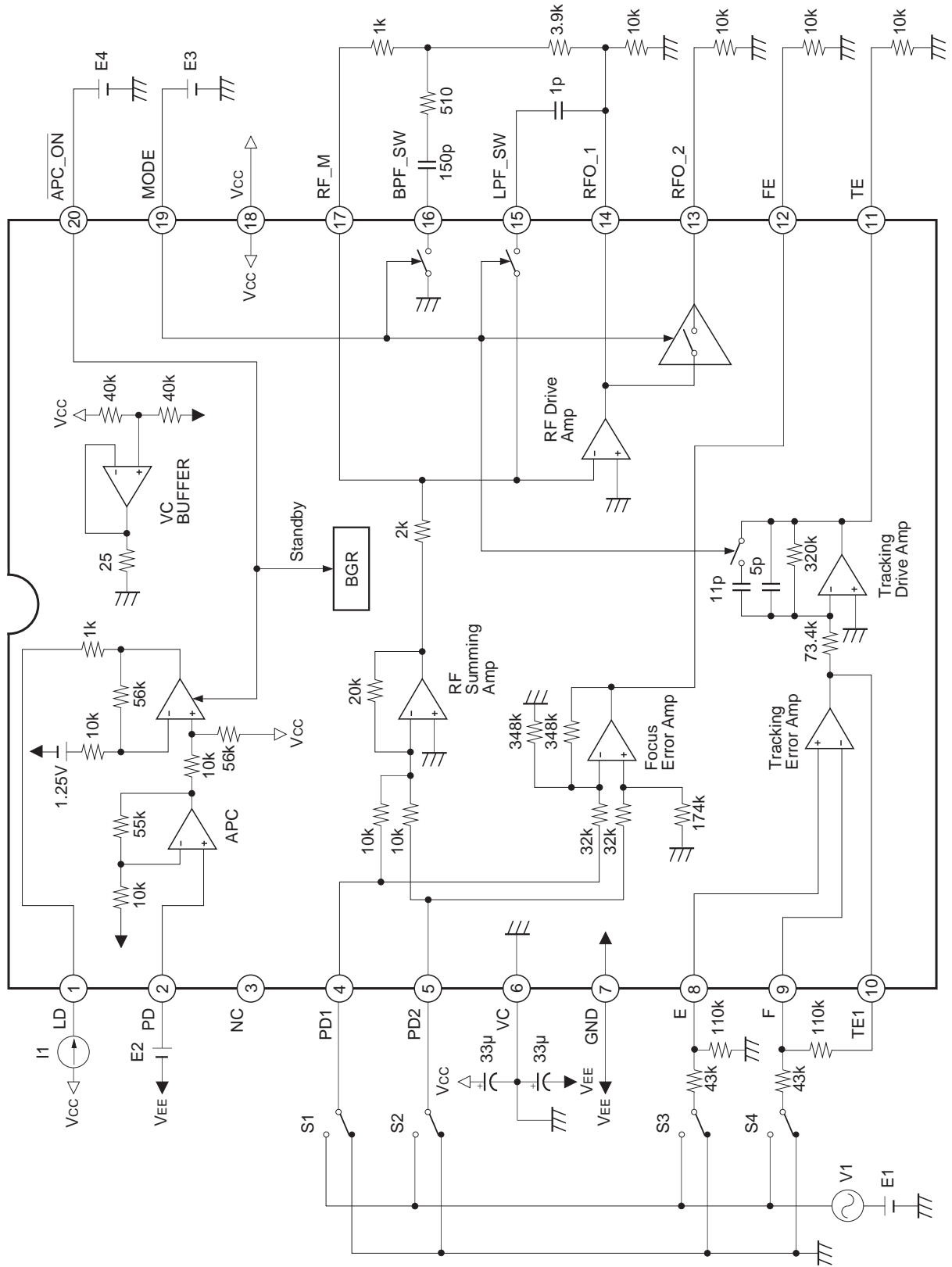

Application Circuit (Double-/sextuple-speed switching)

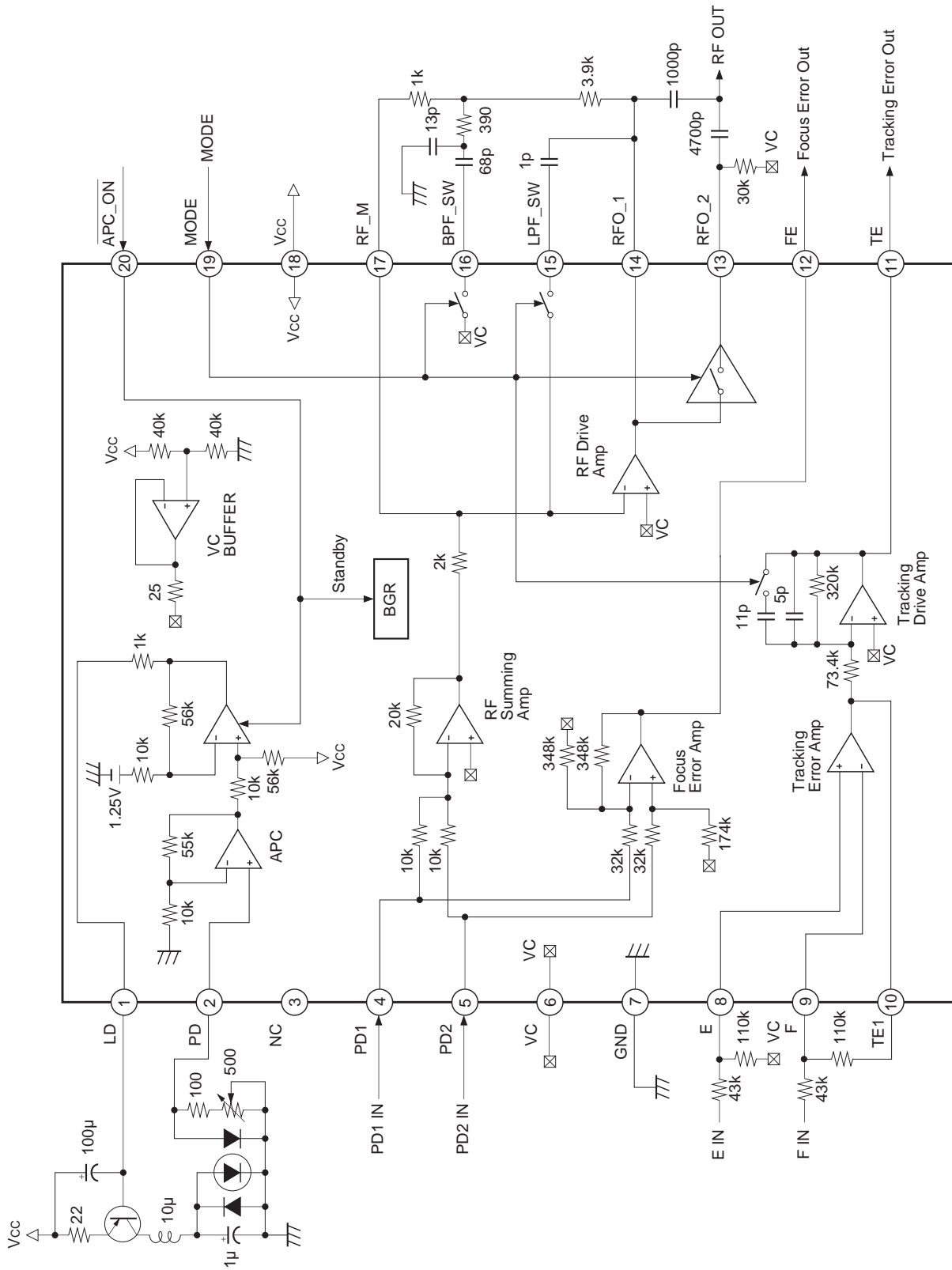

Application circuits shown are typical examples illustrating the operation of the devices. Sony cannot assume responsibility for any problems arising out of the use of these circuits or for any infringement of third party patent and other right due to same.

Note on Operation

The RF AC maximum output amplitude is 1.3Vpp when Pin 13 and 14 are capacitor-coupled shown in Application Circuit.

Description of Operation

RF Amplifier

The signal currents from the photodiodes A, B, C and D become PD1 = A + C and PD2 = B + D by I-V converting, and they are input to Pins 4 and 5. These signals are added at the RF summing amplifier and inverted at the RF drive amplifier and then output to Pin 14.

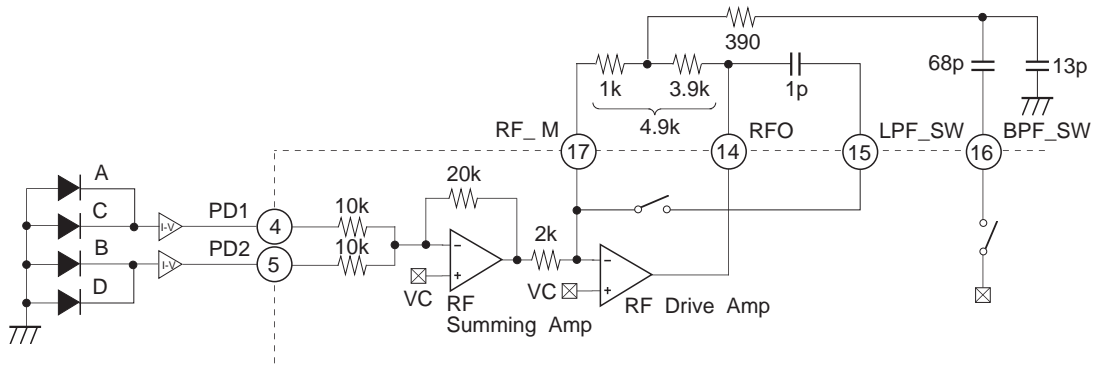

The low frequency component of RFO output voltage is as follows:

$$V_{RFO} = \frac{20k}{10k} \times \frac{4.9k}{2k} \times (PD1 + PD2)$$

$$= 4.9 \times (PD1 + PD2)$$

Focus Error Amplifier

The operation of (PD2 – PD1) is performed and the resulting signal is output to Pin 12.

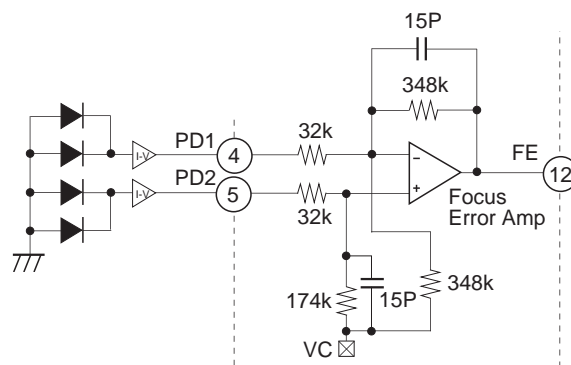

The low frequency component of FE output voltage is as follows:

$$V_{FE} = \frac{348k}{32k} \times (PD2 - PD1)$$

$$= 10.9 \times (PD2 - PD1)$$

Tracking Error Amplifier

The signal current from the photodiode F is I-V converted and input to Pin 9 via an input resistor. The signal current from the photodiode E is I-V converted, and input to Pin 8 after its gain is adjusted by the volume. These signals undergo operational amplification at the tracking error amplifier and tracking drive amplifier, and are output to Pin 12.

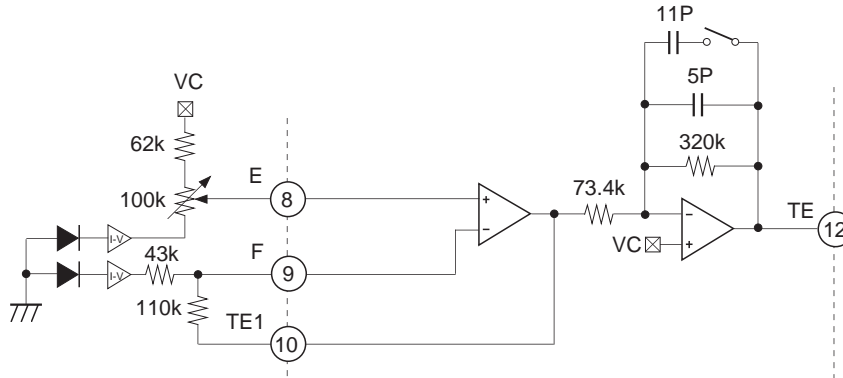

The low frequency component of TE output voltage is as follows:

$$V_{TE} = \frac{110k}{43k} \times \frac{320k}{73.4k} \times (F - E)$$

$$= 11.1 \times (F - E)$$

Center Voltage Generation Circuit

The center voltage of VR = (Vcc + GND) is supplied. The maximum current is approximately ±3mA.

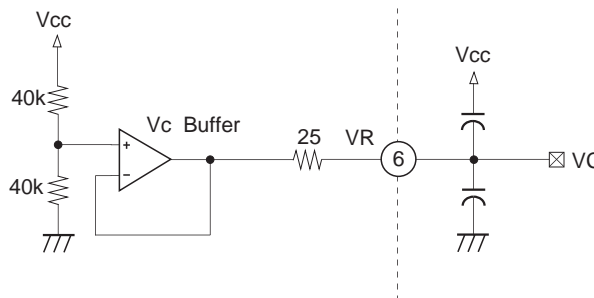

APC Circuit

When the laser diode is driven with constant current, the optical output possesses large negative temperature characteristics. Therefore, the current must be controlled with the monitor photodiode to ensure the output remains constant. When APC_ON pin is connected to GND, APC is ON; connected to Vcc, it is OFF.

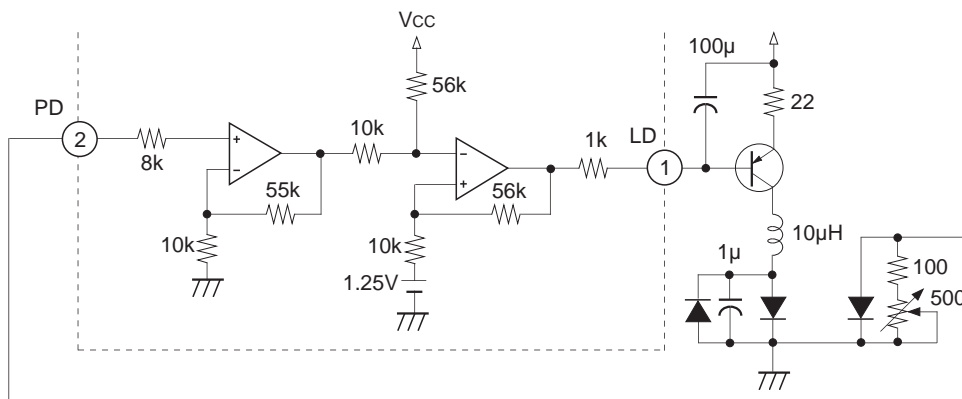

Example of Representative Characteristics

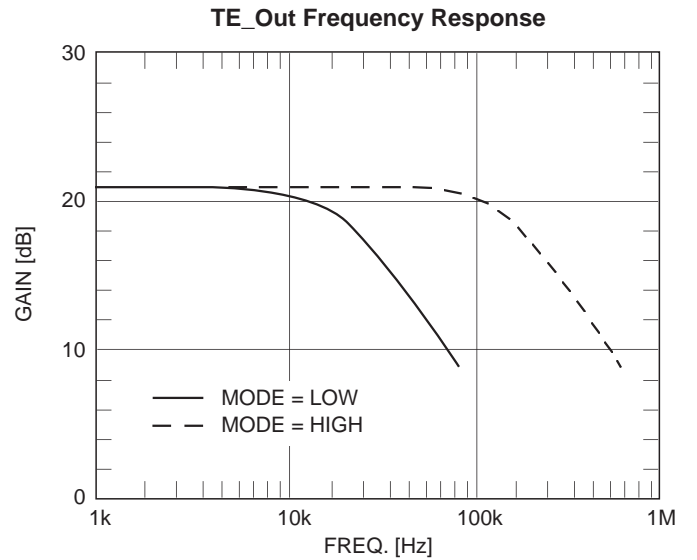
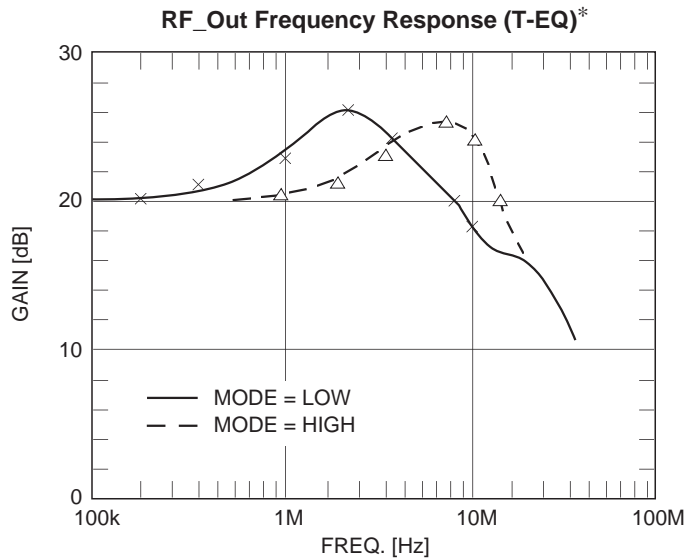
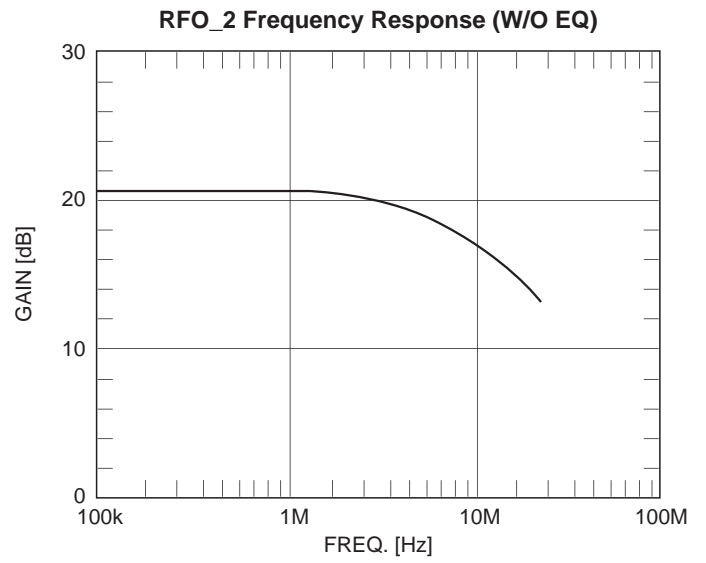
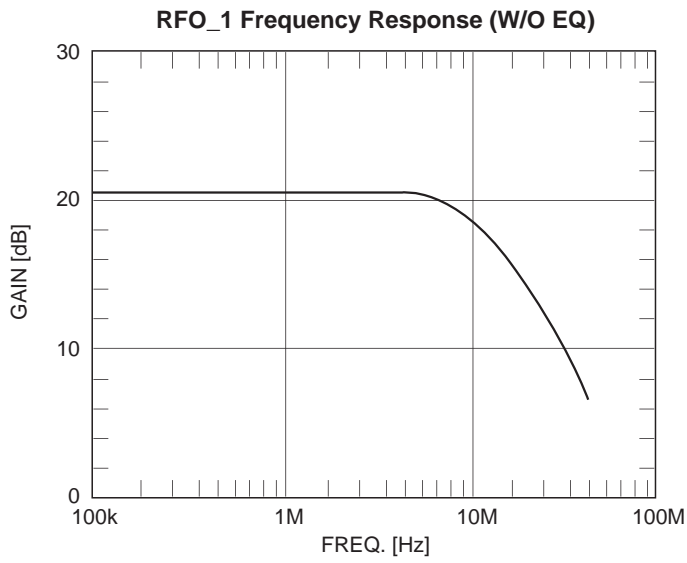

* T-EQ As shown in Application Circuit

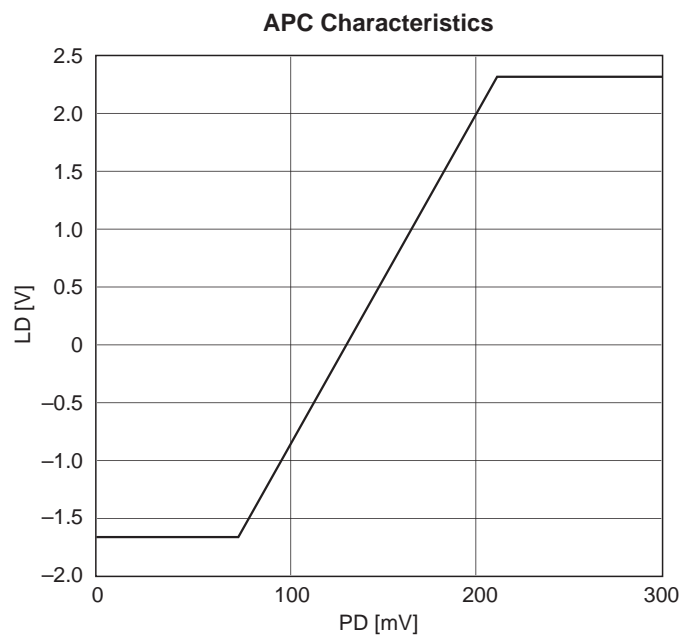
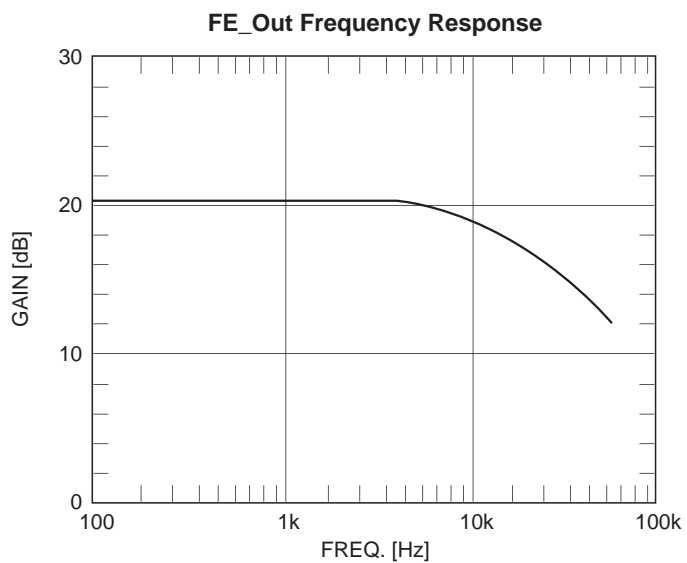

Package Outline Unit: mm

CXA2515AM

20PIN SOP (PLASTIC) 300mil

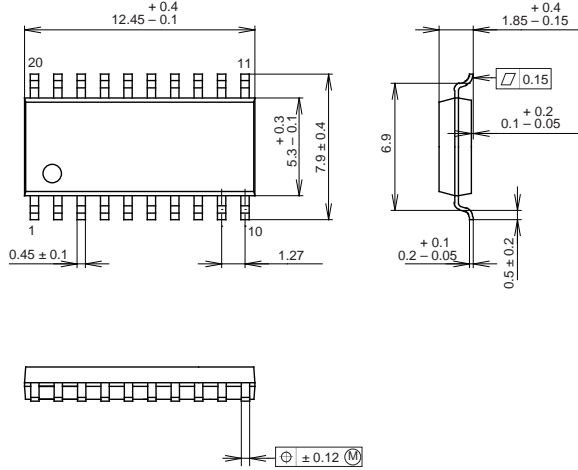

PACKAGE STRUCTURE

SONY CODE	SOP-20P-L01
EIAJ CODE	+SOP020-P-0300-A
JEDEC CODE	

PACKAGE MATERIAL	EPOXY / PHENOL RESIN
LEAD TREATMENT	SOLDER PLATING
LEAD MATERIAL	COPPER ALLOY
PACKAGE WEIGHT	0.3g

CXA2515AN

20PIN SSOP (PLASTIC)

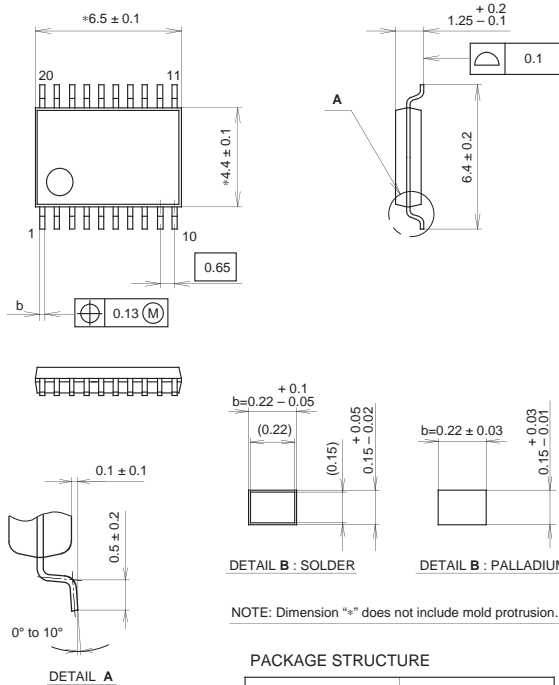

DETAIL B : SOLDER

DETAIL B : PALLADIUM

NOTE: Dimension "*" does not include mold protrusion.

PACKAGE STRUCTURE

SONY CODE	SSOP-20P-L01
EIAJ CODE	SSOP020-P-0044
JEDEC CODE	

PACKAGE MATERIAL	EPOXY RESIN
LEAD TREATMENT	SOLDER / PALLADIUM PLATING
LEAD MATERIAL	42/COPPER ALLOY
PACKAGE MASS	0.1g

NOTE : PALLADIUM PLATING

This product uses S-PdPPF (Sony Spec.-Palladium Pre-Plated Lead Frame).

This datasheet has been downloaded from:

www.DatasheetCatalog.com

Datasheets for electronic components.



LittleDiode supplies new, hard to find or obsolete electronic components and semiconductors all over the world.

With over two million different components listed you are sure to find the part you need.

Feel free to visit us today at our online store:

LittleDiode.com

Looking forward to providing you with the best possible service.