

3-Band Preset Graphic Equalizer IC (with standby and memory on last preset mode)

Description

The CXA2513M is a 3-band preset graphic equalizer developed for stereo set, cassette tape recorder with radio, etc. It has 5 modes: FLAT, ROCK, VOCAL, POP and JAZZ. The selection is via 5 control pins. The center frequencies of three bands are 100Hz, 1kHz and 10kHz. The center frequencies of these bands are determined by 2 external resistors. It also has a standby feature. When the standby pin goes low, the IC stores the last preset mode. When this pin goes high, the IC restores the last preset mode before standby. It can be initialized to any one of the two preset modes (FLAT, ROCK) upon power up.

Features

- Very few external parts
- 3-band monolithic filters (100Hz, 1kHz, 10kHz)
- The center frequencies of the band-pass filters can be adjusted
- 5 preset modes (FLAT, ROCK, VOCAL, POP, JAZZ)
- Equips with output ports to drive external LEDs
- Mute pulse output pin
- Standby feature with last preset mode memory
- Can be initialized to one of the two preset modes (FLAT or ROCK)

Applications

Preset graphic equalizer for cassette tape recorder with radio and portable stereo

Structure

Bipolar silicon monolithic IC

20 pin SOP (Plastic)

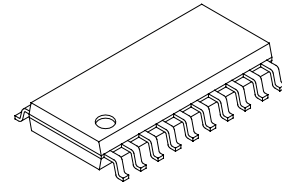

Absolute Maximum Ratings (Ta = 25°C)

- | | | | |
|-------------------------------|------------------|----------------|----|
| • Supply voltage | V _{CC} | 12 | V |
| • Allowable power dissipation | P _D | 600 | mW |
| • Storage temperature | T _{stg} | -65 to +150 °C | |

Recommended Operating Conditions

- | | | | |
|-------------------------|------------------|---------------|---|
| • Supply voltage | V _{CC} | 4.5 to 10 | V |
| • Operating temperature | T _{opr} | -20 to +75 °C | |

Sony reserves the right to change products and specifications without prior notice. This information does not convey any license by any implication or otherwise under any patents or other right. Application circuits shown, if any, are typical examples illustrating the operation of the devices. Sony cannot assume responsibility for any problems arising out of the use of these circuits.

Block Diagram and Pin Configuration

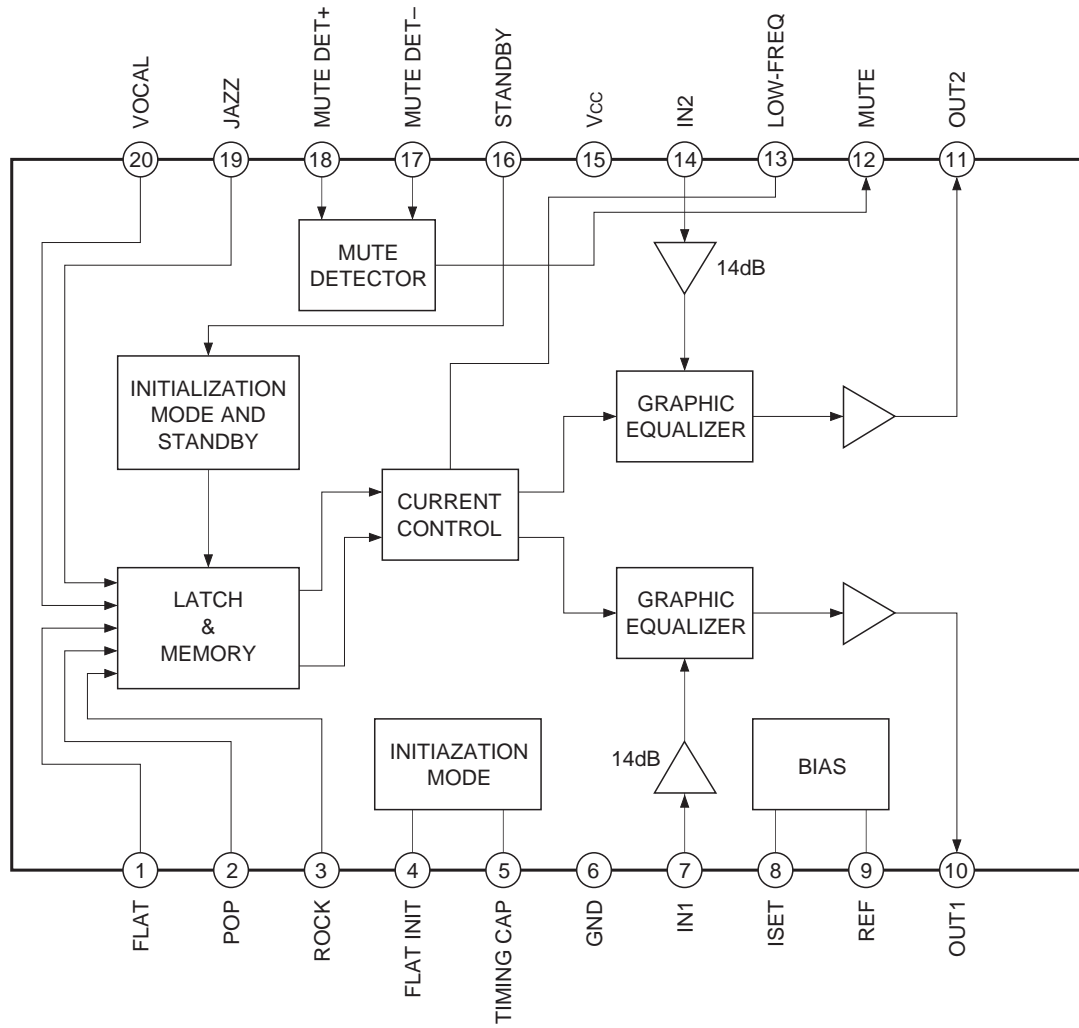

Pin Description

Pin No.	Symbol	Voltage	I/O resistance	Equivalent circuit	Description
1 2 3 19 20	FLAT POP ROCK JAZZ VOCAL	V _{cc} or 1V	—		Mode selection input pins with LED driving capability.
4	FLAT INIT	—	—		Flat initialization pin. If the pin is connected to a 220nF capacitors, it initializes to FLAT mode. If the pin is not connected, it initializes to ROCK mode.
5	TIMING CAP	V _{cc} – 5*V _{BE}	—		Timing capacitor pin. It is connected to a capacitor. The charging and discharging of this capacitor will determine the timing of the logic control.
6	GND	GND			GND pin.

Pin No.	Symbol	Voltage	I/O resistance	Equivalent circuit	Description
7 14	IN1 IN2	$V_{cc}/2$	50k		Signal input pin.
8	ISET	1.2V	—		Reference current setting pin (for graphic equalizer). Normally 160kΩ resistor is connected.
9	REF	$V_{cc}/2$	40k		Signal reference voltage pin. A capacitor is connected for ripple rejection.
10 11	OUT1 OUT2	$V_{cc}/2$	0		Signal output pin.

Pin No.	Symbol	Voltage	I/O resistance	Equivalent circuit	Description
12	MUTE	0	300k		Mute pulse output pin.
13	LOW FREQ	Vcc	0		Low frequency adjustment pin. Set the center frequency of the bass.
15	Vcc	Vcc	—		Power supply pin.
16	STAND BY	—	20k		Standby pin. When not connected, the IC in standby. When connected to Vcc, the IC in normal operation
17	MUTE DET-	—	—		Negative input of the mute detector comparator.
18	MUTE DET+	—	—		Positive input of the mute detector comparator.

Electrical Characteristics (Ta = 27°C, Vcc = 8V, C = 22µF)

Symbol	Parameter		Measurement conditions	Min.	Typ.	Max.	Unit	
Icc (STANDBY)	Current consumption		Standby pin is low - No input	—	17.5	45.0	µA	
Icc (FLAT)	Current consumption		FLAT mode - No input	—	9.6	14.0	mA	
Vout (max.)	Maximum output level		FLAT preset mode, f = 1kHz @ THD = 1%, RL = 10kΩ	2.7	3.0	—	Vpeak	
GE (FLAT) B	PRESETS	Normal	Bass	Vin = 0.05Vrms, fo = 100Hz	12.6	14.6	16.6	dB
GE (FLAT) M			Mid	Vin = 0.05Vrms, fo = 1kHz	12.55	14.55	16.55	dB
GE (FLAT) T			Treble	Vin = 0.05Vrms, fo = 10kHz	12.5	14.5	16.5	dB
GE (POP) M		POP	Mid Boost	Vin = 0.05Vrms, fo = 0.8 to 1.2kHz	16.5	19.0	21.5	dB
GE (POP) T			Treble Boost	Vin = 0.05Vrms, fo = 0.8 to 12kHz	18.0	21.0	24.0	dB
GE (ROCK) B		ROCK	Bass Boost	Vin = 0.05Vrms, fo = 0.8 to 120Hz	21.0	24.0	27.0	dB
GE (ROCK) T			Treble Boost	Vin = 0.05Vrms, fo = 0.8 to 12kHz	20.0	23.0	26.0	dB
GE (VOCAL) B		VOCAL	Bass Boost	Vin = 0.05Vrms, fo = 0.8 to 120Hz	14.5	17.0	19.5	dB
GE (VOCAL) M			Mid Boost	Vin = 0.05Vrms, fo = 0.8 to 1.2kHz	20.0	23.0	26.0	dB
GE (JAZZ) B		JAZZ	Bass Boost	Vin = 0.05Vrms, fo = 0.8 to 120Hz	16.2	18.7	21.2	dB
GE (JAZZ) M			Mid Boost	Vin = 0.05Vrms, fo = 0.8 to 1.2kHz	15.5	18.0	20.5	dB
GE (JAZZ) T			Treble Cut	Vin = 0.05Vrms, fo = 0.8 to 12kHz	5.5	8.0	10.5	dB
Bal		Balance		GE (Out1) – GE (Out2)	–1	0	1	dB
Δfo		Center frequency deviation			–20	0	20	%
THD	Total harmonic distortion		RL = 10kΩ, FLAT preset mode, f = 1kHz, Vin = 0.1Vrms	—	0.25	1	%	
VNOIS (FLAT)	Noise level		RL = 10kΩ, FLAT preset mode, DIN AUDIO filter, Vin = 0Vrms	—	19	55	µVrms	
Cs	Channel separation		Vin = 0.1Vrms at 1kHz, FLAT preset mode	40	47	—	dB	
PSRR	Power supply ripple rejection		Vin = 0.1Vrms at 100Hz, FLAT preset mode	40	46	—	dB	
ILED	Maximum LED drive current		Current flowing through LED connected to a switch depressed	15	—	—	mA	
Vmute (off)	Mute off voltage		Vm_det+ = 1/4Vcc and Vm_det– = 1/2Vcc	—	0	0.1	V	
Vmute (on)	Mute on voltage		Vm_det+ = 3/4Vcc and Vm_det– = 1/2Vcc	6.8	7.1	—	V	
Vstandby (off)	Standby off voltage		Icc goes from standing to normal operation	3	—	—	V	

Switches Statuses

Item	S1	S2	S3	S4	S5	S6	S7	S8	S9	S10	S11	S12	Input pins	Test Pt.
1	—	—	—	—	—	•	•	3	off	•	on	off	—	Icc
2	•	—	—	—	—	•	•	2	off	•	on	off	—	Icc
3	•	—	—	—	—	•	•	2	on	•	on	off	V3 V4	Out1 Out2
4	•	—	—	—	—	•	•	2	on	•	on	off	V3 V4	Out1 Out2
5	—	•	—	—	—	•	•	2	on	•	on	off	V3 V4	Out1 Out2
6	—	—	•	—	—	•	•	2	on	•	on	off	V3 V4	Out1 Out2
7	—	—	—	•	—	•	•	2	on	•	on	off	V3 V4	Out1 Out2
8	—	—	—	—	•	•	•	2	on	•	on	off	V3 V4	Out1 Out2
9	•	—	—	—	—	•	•	2	on	•	on	off	V3 V4	Out1 Out2
	—	•	—	—	—								V3 V4	Out1 Out2
	—	—	•	—	—								V3 V4	Out1 Out2
	—	—	—	•	—								V3 V4	Out1 Out2
	—	—	—	—	•								V3 V4	Out1 Out2
10	•	—	—	—	—	•	•	2	on	•	on	off	V3 V4	Out1 Out2
	—	•	—	—	—								V3 V4	Out1 Out2
	—	—	•	—	—								V3 V4	Out1 Out2
	—	—	—	•	—								V3 V4	Out1 Out2
	—	—	—	—	•								V3 V4	Out1 Out2

Item	S1	S2	S3	S4	S5	S6	S7	S8	S9	S10	S11	S12	Input pins	Test Pt.
11	•	—	—	—	—	•	•	2	on	•	on	off	V3 V4	Out1 Out2
12	•	—	—	—	—	•	•	2	on	•	on	off	V3 = 0 V4 = 0	Out1 Out2
13	•	—	—	—	—	•	•	2	on	•	on	off	V4 V3	Out1 Out2
14	•	—	—	—	—	•	•	2	on	O	off	off	V5 V5	Out1 Out2
15	•	—	—	—	—	O	•	2	on	•	on	off	—	—
16	•	—	—	—	—	•	•	2	on	•	on	off	—	Mute
17	•	—	—	—	—	•	O	2	on	•	on	off	—	Mute
18	•	—	—	—	—	•	•	3	on	•	on	off	V2	Icc

Application Circuit

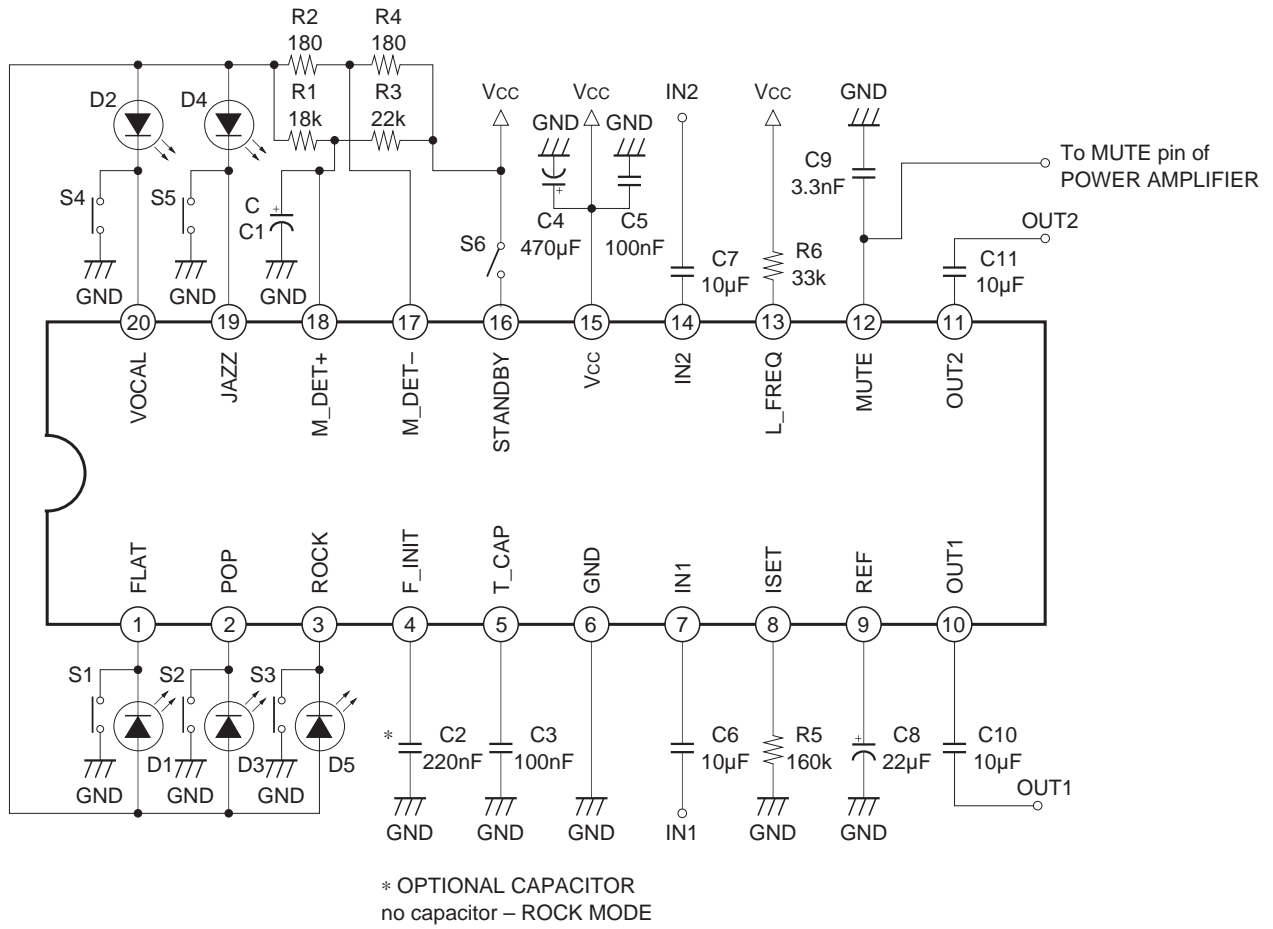

Application circuits shown are typical examples illustrating the operation of the devices. Sony cannot assume responsibility for any problems arising out of the use of these circuits or for any infringement of third party patent and other right due to same.

Description of Operation

1. Graphic Equalizer

- Conventional system

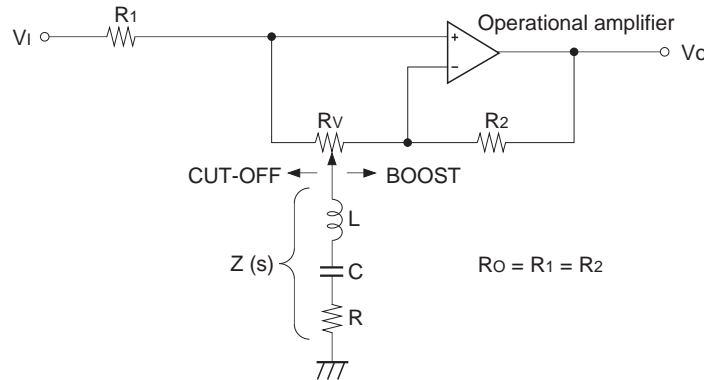

Fig. 1

Fig. 1 indicates the conventional graphic equalizer system. This circuit performs boost and cut-off near "fo" controlled by the potentiometer Rv. ("fo" is resonance frequency determined by Z (s) (formed LCR).) The operation can be seen as follows: When the LCR circuit goes to the far left of Rv, a state of graphic equalizer becomes maximum cut-off. At that time, assuming transmittance as T (s), the following expression can be obtained.

$$T (s) = \frac{Z (s)}{Z (s) + R_o}$$

Here as $Z (s) = sL + R + \frac{1}{sC}$

Then $T (s) = \frac{LCs^2 + RCs + 1}{LCs^2 + (R + R_o) Cs + 1}$

Defining fo as $f_o = \frac{\omega_o}{2\pi}$, ω_o as $\omega_o = \frac{1}{LC}$, and Q as $Q = \frac{\omega_o L}{R}$, the frequency response can be obtained at cut-off

Also, when LCR circuit goes to the far right of Rv, a state of graphic equalizer becomes maximum boost. At that time transmittance is:

$$T (s) = \frac{Z (s) + R_o}{Z (s)} = \frac{LCs^2 + (R + R_o) Cs + 1}{LCs^2 + RCs + 1}$$

Defining fo, ω_o and Q as for cut-off the frequency response can be obtained at boost.

Fig. 2 indicates frequency response at boost and cut-off.

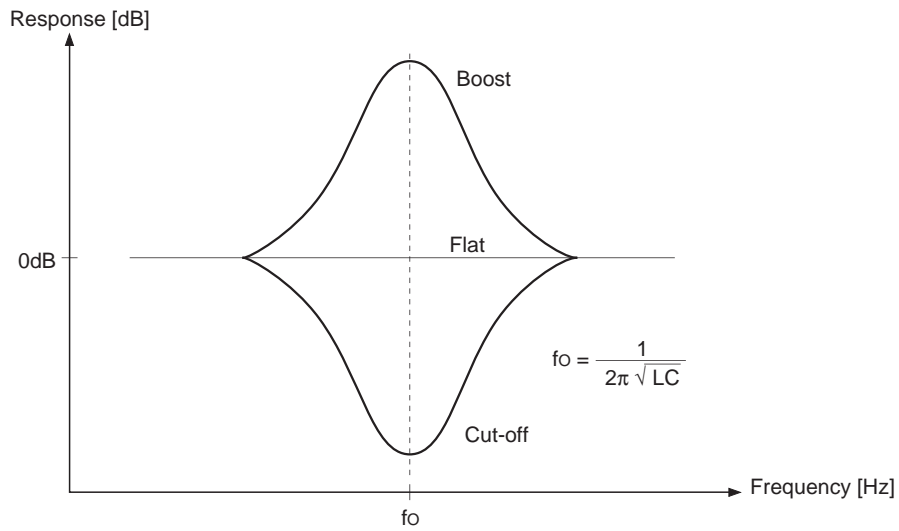

Fig. 2

• CXA2513M system

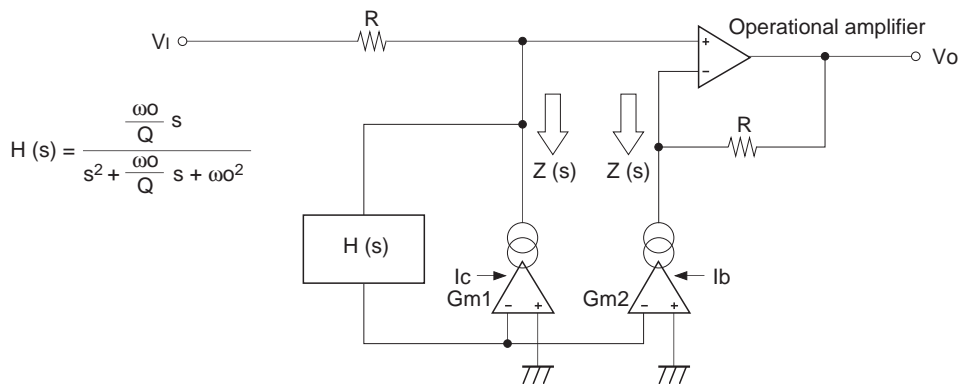

Fig. 3

The structure of the graphic equalizer used in this IC is shown on Fig. 3. This circuit performs boost and cut-off controlled by 2 transconductance amplifiers that can vary the conversion coefficient through control currents I_b , and I_c around ω_0 . (" ω_0 " is center frequency determined by band-pass filter.) Output impedance $Z(s)$ of $Gm1$, $Gm2$ can be expressed as

$$T(s) = \frac{1}{H(s) \cdot Gm1}$$

Here, using ω_0 and Q BPF transmittance H (s) is expressed as

$$H(s) = \frac{\frac{\omega_0}{Q} s}{s^2 + \frac{\omega_0}{Q} s + \omega_0^2}$$

$$H(s) = \frac{Q}{\omega_0 \cdot Gm1} s + \frac{1}{Gm1} + \frac{\omega_0 \cdot Q}{Gm1 \cdot s}$$

The formula shows that this system and the aforementioned LCR circuit have equivalent impedance characteristics on Z (s).

Then, regarding Gm as the maximum value of Gm1 and Gm2, the operation can be observed as follows. Maximum cut-off occurs when Gm1 = Gm and Gm2 = 0. At that time transmittance T (s) is expressed as

$$T(s) = \frac{Z(s)}{Z(s) + R} = \frac{s^2 + \frac{\omega_0}{Q} \cdot s + \omega_0^2}{s^2 + \frac{(1 + R \cdot Gm) \cdot \omega_0^2}{Q} \cdot s + \omega_0^2}$$

This is equal to the frequency response of the conventional graphic equalizer at cut-off.

Also, maximum boost occurs when Gm1 = 0 and Gm2 = Gm. At that time transmittance T (s) is given by as

$$T(s) = \frac{Z(s) + R}{Z(s)} = \frac{s^2 + \frac{(1 + R \cdot Gm) \cdot \omega_0^2}{Q} \cdot s + \omega_0^2}{s^2 + \frac{\omega_0}{Q} \cdot s + \omega_0^2}$$

This is equal to the frequency response of the conventional graphic equalizer at boost.

As far as the operation is concerned the graphic equalizer on this IC and the conventional graphic equalizer are equal, even when the system differs. The merit in using this IC's system rests with the fact that monolithic filter technology realizes a graphic equalizer without external parts.

The structure of the actual graphic equalizer, including BPF, is shown on Fig. 4.

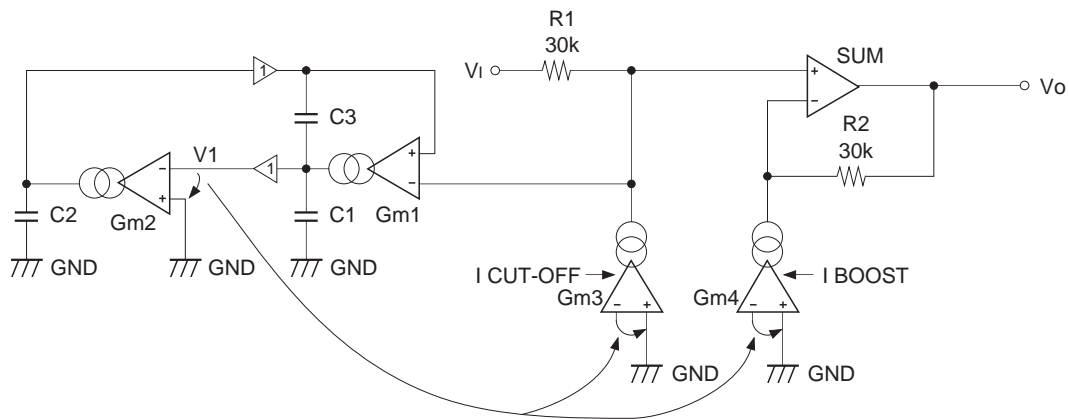

Fig. 4

2. Power Up

There are two ways of powering up the CXA2513M. They are

- 1) Vcc pin (Pin 15) goes high, and after some time, the STANDBY pin (Pin 16) goes high.
- 2) Vcc pin and STANDBY pins both goes high together.

The two ways of power-up will results in different timing diagram and different initial mode.

If both Vcc and STANDBY pins go high together, the REF capacitor (Pin 9) will charge to half Vcc. The IC will be initialized to ROCK mode. The timing diagram is shown in Fig. 5.

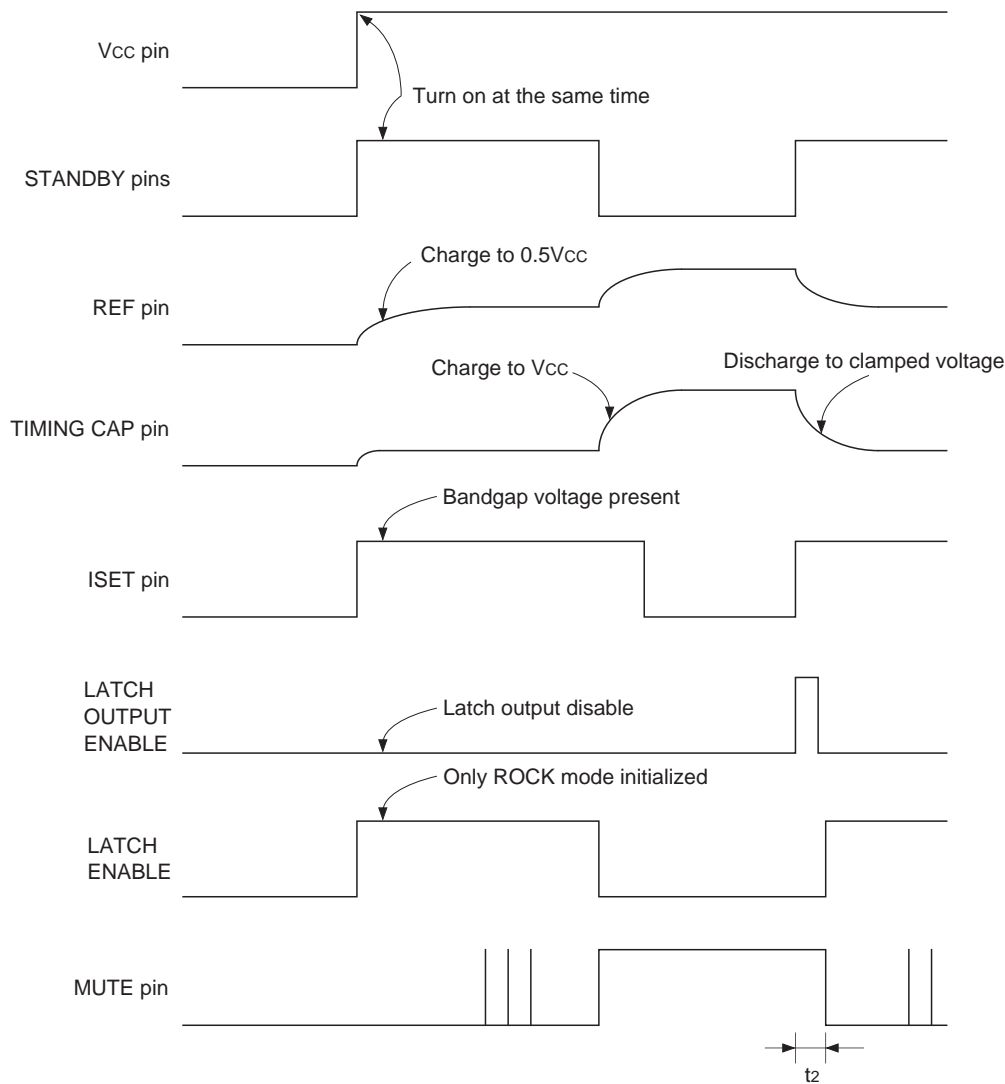

Fig. 5

If the Vcc pin goes high while the STANDBY pin is not connected to Vcc, the IC is in standby condition. The REF capacitor (Pin 9) and timing capacitor (Pin 5) will charge to Vcc. Now, if the STANDBY pin is switched to Vcc, the REF capacitor will discharge to half Vcc and the timing capacitor will discharge to a clamped voltage ($V_{cc} - 5 \cdot V_{BE}$).

During the discharging of timing capacitor, all the LEDs light up. When the timing capacitor voltage reaches a certain threshold voltage, only the ROCK LED or FLAT LED lights up depending on Pin 4. If the Pin 4 is connected to a capacitor, the IC is initialized to FLAT mode. If the Pin 4 is not connected, the IC is initialized to ROCK mode. The timing diagram is shown in Fig. 6.

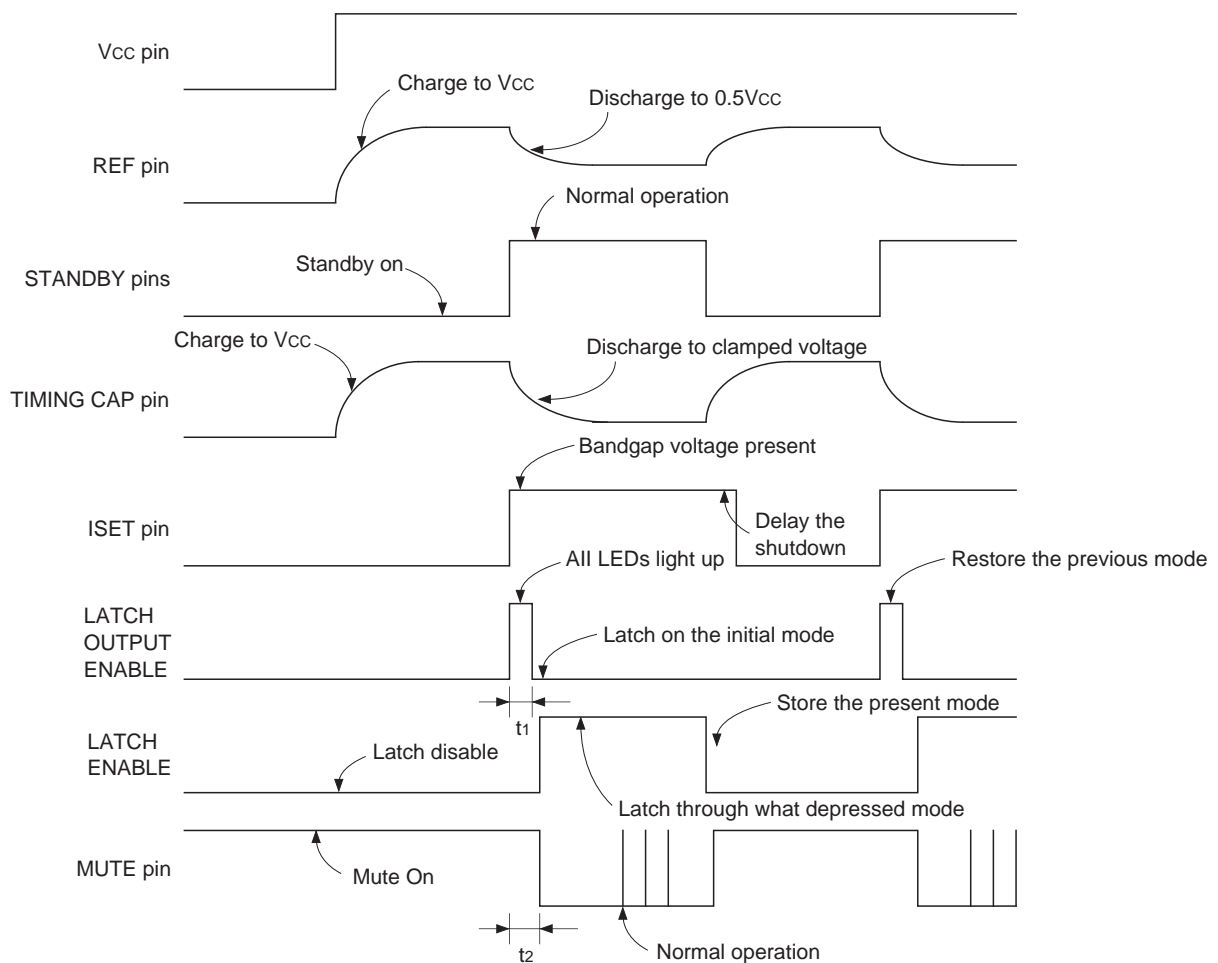

Fig. 6

3. Mute Pulse Generation

The CXA2513M has one voltage comparator built-in. The built-in voltage comparator is used to produce mute pulse during the depress of the preset mode switches. During depress the switch, there is a voltage pulse of about 1V depending appearing at the cathode of the LEDs.

The mute detector comparator is used to detect this voltage changes at the cathode of LEDs and produce mute pulse at Pin 12. The polarity of the mute pulse can be set. When the M_DET+ pin (Pin 18) is higher than the M_DET- pin (Pin 17), the MUTE pin (Pin 12) will be high. When the M_DET+ pin (Pin 18) is lower than the M_DET- pin (Pin 17), the MUTE pin (Pin 12) becomes low.

A capacitor is used to store the initial voltage before the depression of the mode switch. Once the switch is depressed, the capacitor starts discharge. The values of the resistors and capacitor set the duration of the mute pulse.

Notes on Operation

1) Value of Timing Capacitor

The timing and the duration of the MUTE pin and the LEDs light-up depends on the value of the timing capacitor as the timing capacitor is discharging to $(V_{CC} - 5 \cdot V_{BE})$.

The charging time constant is $250K \cdot (\text{timing capacitor})$ and the discharging time constant is $150K \cdot (\text{timing capacitor})$.

The two threshold values:

- a) Latch Output Enable (LATCH_OE_ctl)
- b) Latch enable/Mute disable (LATCH_ctl)

The threshold values of the Latch Output Enable (LATCH_OE_ctl) is set to $(V_{CC} - 3 \cdot V_{BE})$ and the threshold values of the Latch enable/Mute disable (LATCH_ctl) is set to $(V_{CC} - 4 \cdot V_{BE})$.

So, the duration for all the LEDs light-up is

$$2 \cdot V_{BE} = (5V_{BE}) \exp(-t_1/RC)$$

where $R = 150K$

and the sound appears after t_2 seconds if the mute pulse output pin is used. This t_2 is given by

$$V_{BE} = (5V_{BE}) \exp(-t_2/RC)$$

where $R = 150K$

Therefore, depending on the requirements of the time on the mute sound and the duration of all LEDs light-up, choose the value of the timing capacitors.

2) Initialize Preset IC

The preset IC can be initialized into any one of the two modes out of the total 5 mods. The two modes are:

- a) FLAT
- b) ROCK

In order to initialize the preset IC into FLAT, one external capacitor (220nF) is required. While to initialize the preset IC to ROCK, no external capacitor is required.

3) Supply voltage Ripple Rejection

The value of the REF capacitor (Pin 9) determines the supply voltage ripple rejection ratio (SVRR). A reduce in this capacitance value decreases on the supply voltage ripple rejection ratio (SVRR).

4) Center Frequency of Band-pass Filters

The center frequency of the graphic equalizer is determined by an external resistor. This resistor is 160k Ω external resistor connected to the ISET pin (Pin 8). It is recommended to use a resistor with the small dispersion and temperature coefficients.

By varying the value of the resistor connected to the ISET pin, the frequency response of the graphic equalizer can be shifted. By reducing the resistor value, all the three band-pass filters shift to high band. By increasing the resistor value, the filters shift to lower band.

The center frequency of the bass band-pass filter can be varied independently. This bass center frequency is determined by the external resistor (33k Ω) connected to the LOW-FREQ pin (Pin 13). By reducing the value of this resistor, the bass center frequency shifts to higher frequency. By this value, the bass center frequency shifts to lower frequency.

LOW-FREQ resistor	Bass center frequency
56k Ω	70Hz
33k Ω	100Hz
10k Ω	200Hz

Example of Representative Characteristics

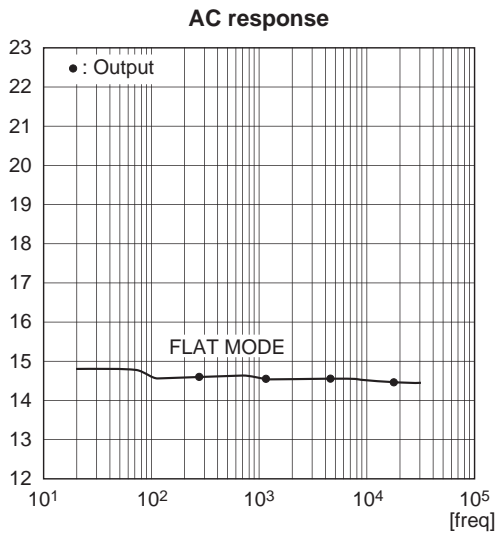

a) Frequency response of FLAT mode

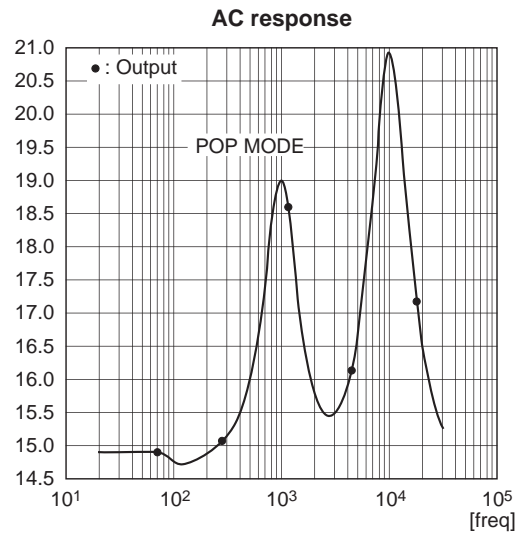

b) Frequency response of POP mode

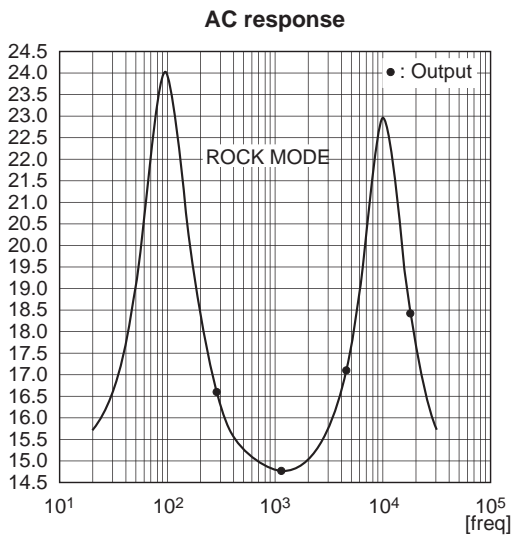

c) Frequency response of ROCK mode

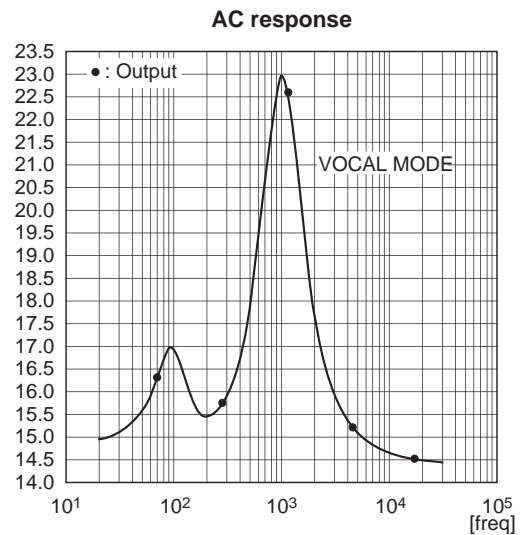

d) Frequency response of VOCAL mode

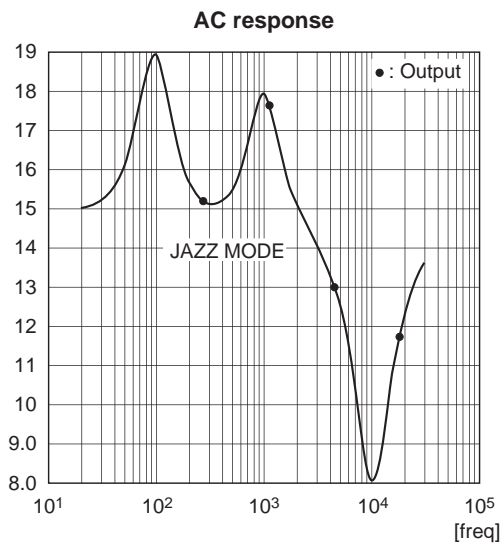

e) Frequency response of JAZZ mode

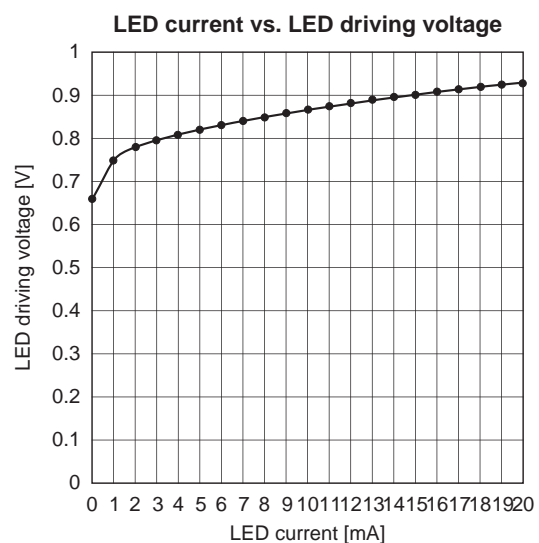

f) LED current vs. LED driving voltage (Pins 1, 2, 3, 19 and 20)

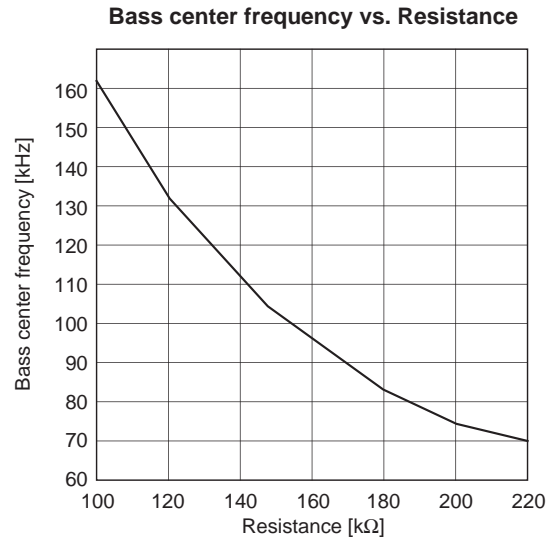
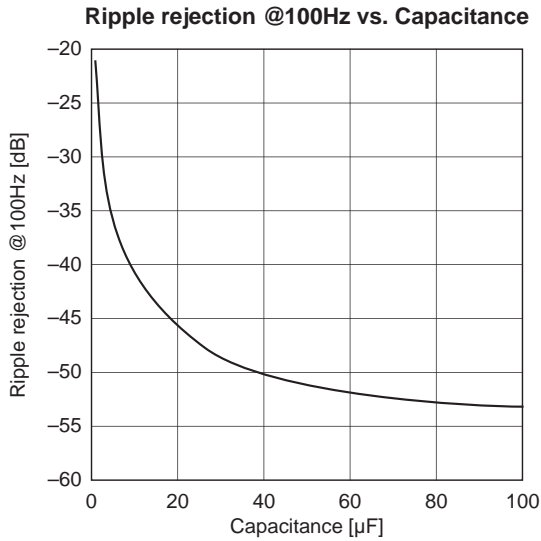

g) Ripple Rejection at 100Hz vs. Reference Capacitor (FLAT MODE)

h) Bass Center Frequency vs. ISET Resistor (L-FREQ Resistor = 33kΩ)

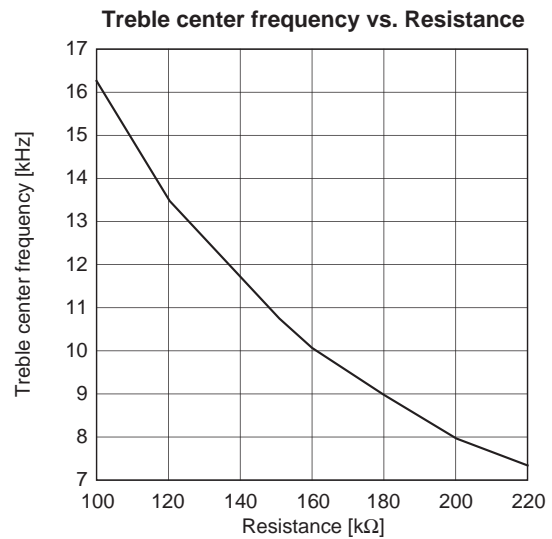
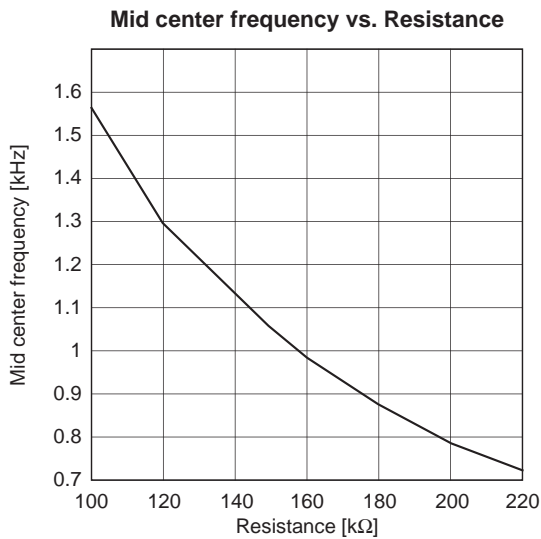

i) Mid Center Frequency vs. ISET Resistor

j) Treble Center Frequency vs. ISET Resistor

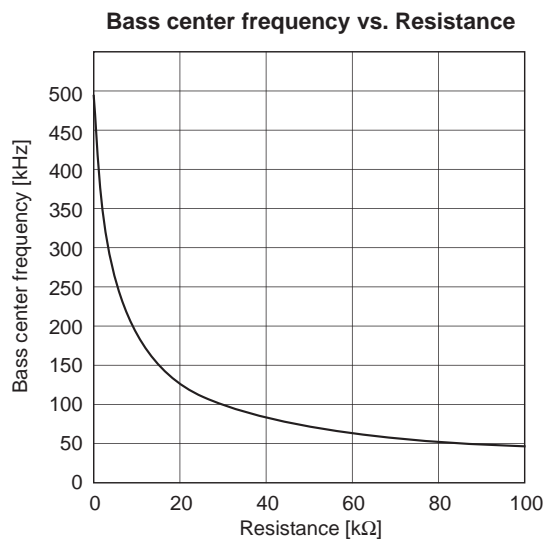

k) Bass Center Frequency vs. L-FREQ Resistor (ISET Resistor = 160kΩ)



LittleDiode supplies new, hard to find or obsolete electronic components and semiconductors all over the world.

With over two million different components listed you are sure to find the part you need.

Feel free to visit us today at our online store:

LittleDiode.com

Looking forward to providing you with the best possible service.