

## US Audio Multiplexing Decoder

### Description

The CXA2174S is an IC designed as a decoder for the Zenith TV Multi-channel System and also corresponds with I<sup>2</sup>C BUS. Functions include stereo demodulation, SAP (Separate Audio Program) demodulation, dbx noise reduction and sound processor. Various kinds of filters are built-in this IC. Adjustment, mode control and sound processor control are all executed through I<sup>2</sup>C BUS.

### Features

- Alignment-free VCO and filter
  - Audio multiplexing decoder
  - dbx noise reduction decoder
  - sound processor
    - One external input
    - Volume control
- are all included in a single chip. Almost any sort of signal processing is possible through this IC.
- Input level, separation adjustments and each mode control are possible through I<sup>2</sup>C bus.

### Applications

TV, VCR and other decoding systems for US audio multiplexing TV broadcasting

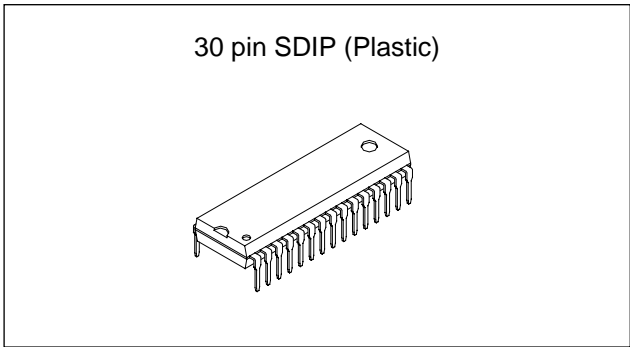

### Structure

Bipolar silicon monolithic IC

### Absolute Maximum Ratings (Ta = 25°C)

- |                               |                  |             |    |
|-------------------------------|------------------|-------------|----|
| • Supply voltage              | V <sub>CC</sub>  | 11          | V  |
| • Operating temperature       | T <sub>opr</sub> | -20 to +75  | °C |
| • Storage temperature         | T <sub>stg</sub> | -65 to +150 | °C |
| • Allowable power dissipation | P <sub>D</sub>   | 1.35        | W  |

### Range of Operating Supply Voltage

9 ± 0.5 V

\* A license of the dbx-TV noise reduction system is required for the use of this device.

### Pin Configuration (Top View)

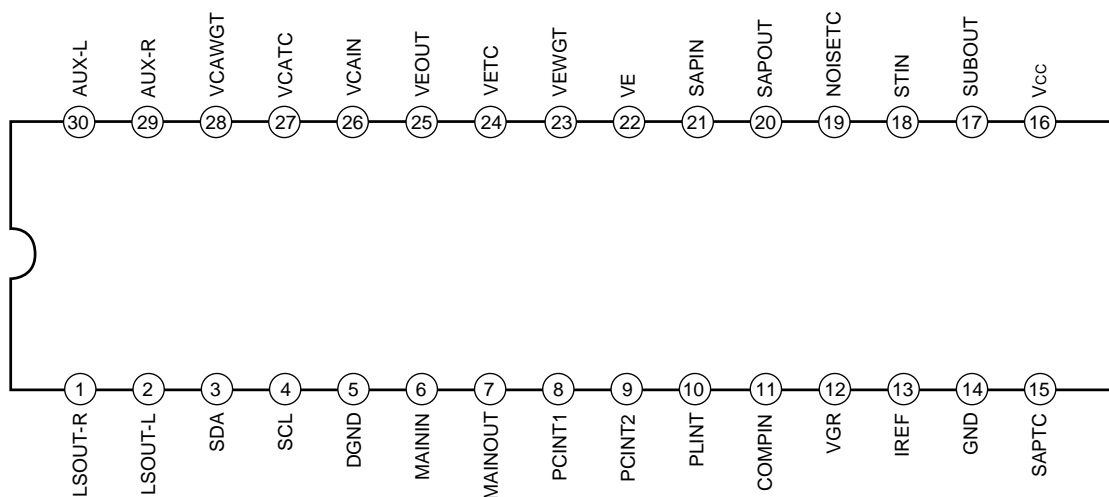

Sony reserves the right to change products and specifications without prior notice. This information does not convey any license by any implication or otherwise under any patents or other right. Application circuits shown, if any, are typical examples illustrating the operation of the devices. Sony cannot assume responsibility for any problems arising out of the use of these circuits.

Block Diagram

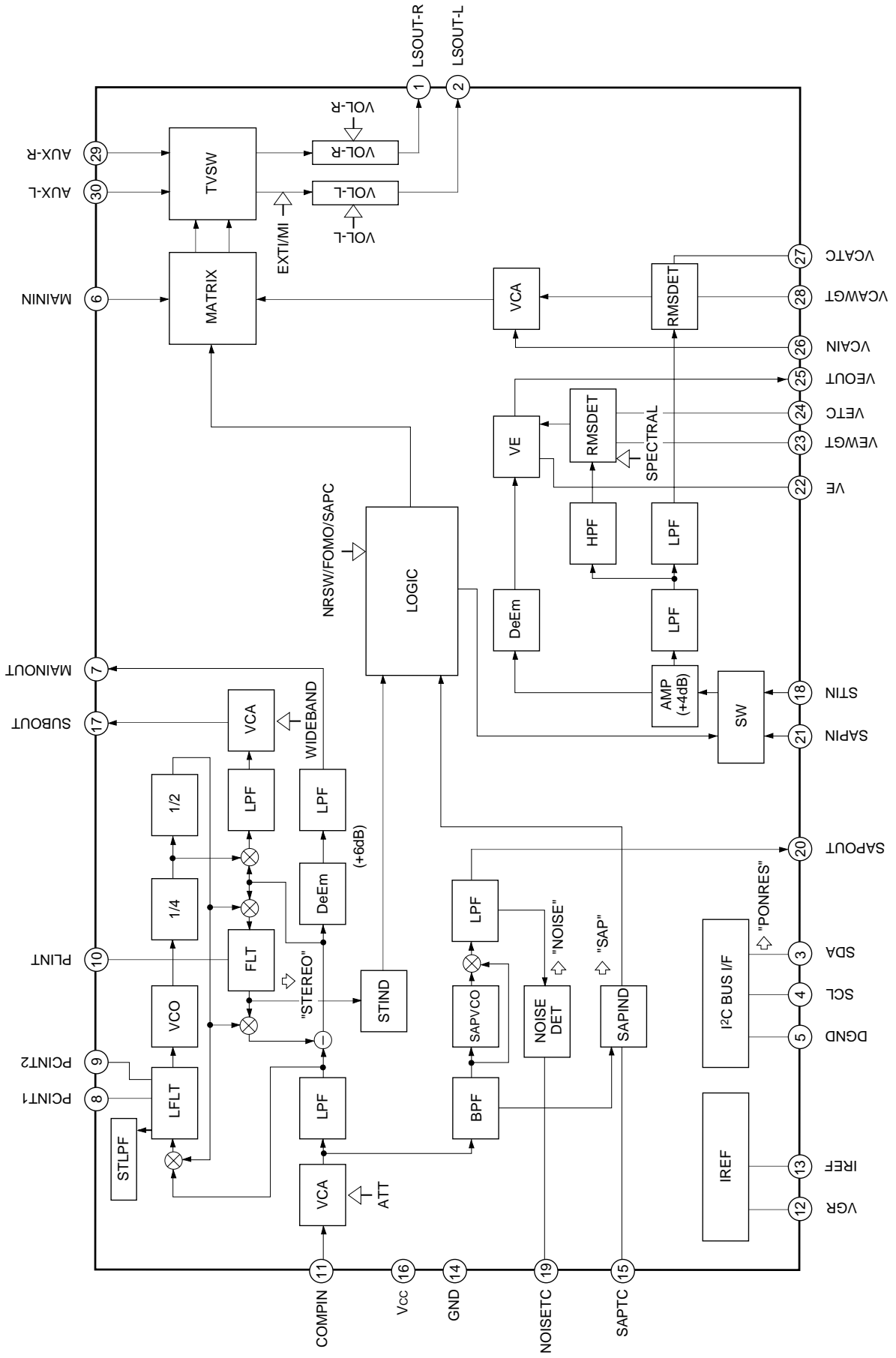

Pin Description

(Ta = 25°C, Vcc = 9V)

| Pin No. | Symbol  | Pin voltage | Equivalent circuit | Description   |
|---------|---------|-------------|--------------------|---|
| 1       | LSOUT-R | 4.0V        |                    | LSOUT right channel output pin.                               |
| 2       | LSOUT-L | 4.0V        |                    | LSOUT left channel output pin.                                |
| 3       | SDA     | —           |                    | Serial data I/O pin.<br>$V_{IH} > 3.0V$<br>$V_{IL} < 1.5V$    |
| 4       | SCL     | —           |                    | Serial clock input pin.<br>$V_{IH} > 3.0V$<br>$V_{IL} < 1.5V$ |
| 5       | DGND    | —           |                    | Digital block GND.  |

| Pin No. | Symbol  | Pin voltage | Equivalent circuit | Description                                    |
|---------|---------|-------------|--------------------|--|
| 6       | MAININ  | 4.0V        |                    | Input the (L + R) signal from MAINOUT (Pin 7). |
| 7       | MAINOUT | 4.0V        |                    | (L + R) signal output pin.                     |
| 8       | PCINT1  | 4.0V        |                    |  |
| 9       | PCINT2  | 4.0V        |                    | Stereo block PLL loop filter integrating pin.  |

| Pin No. | Symbol | Pin voltage | Equivalent circuit | Description  |
|---------|--------|-------------|--------------------|--|
| 10      | PLINT  | 5.1V        |                    | <p>Pilot cancel circuit loop filter integrating pin.<br/>(Connect a 1µF capacitor between this pin and GND.)</p>   |
| 11      | COMPIN | 4.0V        |                    | <p>Audio multiplexing signal input pin.</p>  |
| 12      | VGR    | 1.3V        |                    | <p>Band gap reference output pin.<br/>(Connect a 10µF capacitor between this pin and GND.)</p>   |
| 13      | IREF   | 1.3V        |                    | <p>Set the filter and VCO reference current. The reference current is adjusted with the BUS DATA based on the current which flows to this pin.<br/>(Connect a 62kΩ (±1%) resistor between this pin and GND.)</p> |

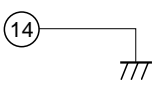
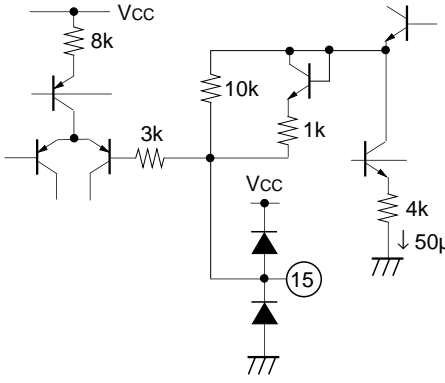
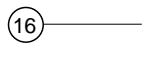
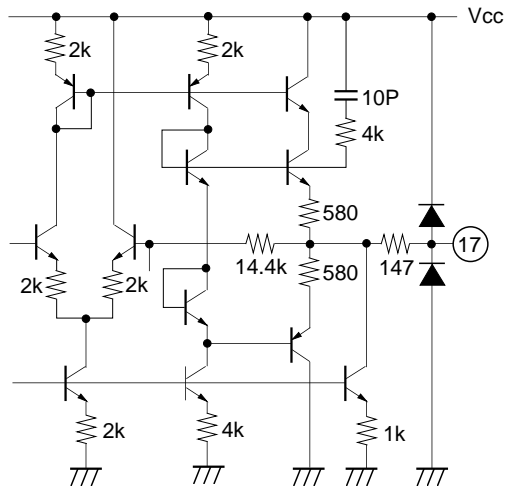
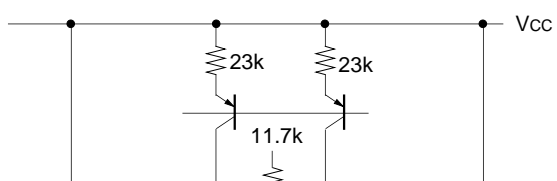
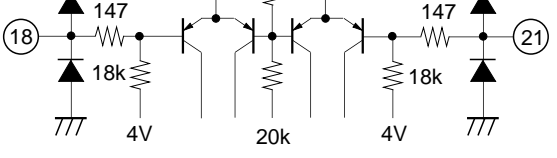
| Pin No. | Symbol | Pin voltage | Equivalent circuit   | Description  |
|---------|--------|-------------|--|--|
| 14      | GND    | —           |     | Analog block GND.  |
| 15      | SAPTC  | 4.5V        |    | Set the time constant for the SAP carrier detection circuit. (Connect a 4.7µF capacitor between this pin and GND.) |
| 16      | Vcc    | —           |     | Supply voltage pin.  |
| 17      | SUBOUT | 4.0V        |   | (L-R) signal output pin.   |
| 18      | STIN   | 4.0V        |  | Input the (L-R) signal from SUBOUT (Pin 17).   |
| 21      | SAPIN  | 4.0V        |  | Input the (SAP) signal from SAPOUT (Pin 20).   |

| Pin No. | Symbol  | Pin voltage | Equivalent circuit | Description   |
|---------|---------|-------------|--------------------|---|
| 19      | NOISETC | 3.0V        |                    | <p>Set the time constant for the noise detection circuit.<br/>(Connect a 4.7<math>\mu</math>F capacitor between this pin and GND.)</p>  |
| 20      | SAPOUT  | 4.0V        |                    | <p>SAP FM detector output pin.</p>  |
| 22      | VE      | 4.0V        |                    | <p>Variable de-emphasis integrating pin.<br/>(Connect a 2700pF capacitor and a 3.3k<math>\Omega</math> resistor in series between this pin and GND.)</p>  |
| 23      | VEWGT   | 4.0V        |                    | <p>Weight the variable de-emphasis control effective value detection circuit.<br/>(Connect a 0.047<math>\mu</math>F capacitor and a 3k<math>\Omega</math> resistor in series between this pin and GND.)</p> |

| Pin No. | Symbol | Pin voltage | Equivalent circuit | Description   |
|---------|--------|-------------|--------------------|---|
| 24      | VETC   | 1.7V        |                    | <p>Determine the restoration time constant of the variable de-rmphasis control effective value detection circuit. (the specified restoration time constant can be obtained by connecting a 3.3µF capacitor between this pin and GND.)</p> |
| 25      | VEOUT  | 4.0V        |                    | <p>Variable de-emphasis output pin. (Connect a 4.7µF non-polar capacitor between Pins 25 and 26.)</p>   |
| 26      | VCAIN  | 4.0V        |                    | <p>VCA input pin. Input the variable de-emphasis output signal from Pin 25 via a coupling capacitor.</p>  |
| 27      | VCATC  | 1.7V        |                    | <p>Determine the restoration time constant of the VCA control effective value detection circuit. (the specified restoration time constant can be obtained by connecting a 10µF capacitor between this pin and GND.)</p>                   |

| Pin No. | Symbol | Pin voltage | Equivalent circuit | Description  |
|---------|--------|-------------|--------------------|--|
| 28      | VCAWGT | 4.0V        |                    | <p>Weight the VCA control effective value detection circuit.<br/>                     (Connect a 1µF capacitor and a 3.9kΩ resistor in series between this pin and GND.)</p> |
| 29      | AUX-R  | 4.0V        |                    | <p>Right channel external input pin.</p>   |
| 30      | AUX-L  | 4.0V        |                    | <p>Left channel external input pin.</p>  |

**Electrical Characteristics**

COMPIN input level  
(100% modulation level)

Main (L + R) (Pre-Emphasis: OFF) = 245mVrms

SUB (L - R) (dbx-TV: OFF) = 490mVrms

Pilot = 49mVrms

SAP Carrier = 147mVrms

$f_H = 15.734\text{kHz}$

( $T_a = 25^\circ\text{C}$ ,  $V_{cc} = 9\text{V}$ )

| No. | Item                                | Symbol              | Mode | Input pin | Input signal  | Measurement conditions             | Filter | Output pin | Min. | Typ. | Max. | Unit  |
|-----|-------------------------------------|---------------------|------|-----------|---|------------------------------------|--------|------------|------|------|------|-------|
| 1   | Current consumption                 | I <sub>cc</sub>     |      | —         | No signal   |                                    |        |            | 23   | 32   | 43   | mA    |
| 2   | Main output level                   | V <sub>main</sub>   | MONO | 11        | Mono 1kHz 100% mod.<br>Pre-em. ON                                     |                                    |        | 1/2        | 440  | 490  | 540  | mVrms |
| 3   | Main de-emphasis frequency response | FC <sub>deem</sub>  | MONO | 11        | Mono 5kHz 30% mod.<br>Pre-em. ON                                      | 20 log ('5k'/1k')                  |        | 1/2        | -1.2 | 0    | 1.0  | dB    |
| 4   | Main LPF frequency response         | FC <sub>main</sub>  | MONO | 11        | Mono 12kHz 30% mod.<br>Pre-em. ON                                     | 20 log ('12k'/1k')                 |        | 1/2        | -3.0 | -1.0 | 1.0  | dB    |
| 5   | Main distortion                     | THD <sub>m</sub>    | MONO | 11        | Mono 1kHz 100% mod.<br>Pre-em. ON                                     |                                    | 15kLPF | 1/2        | —    | 0.1  | 0.5  | %     |
| 6   | Main overload distortion            | THD <sub>mmax</sub> | MONO | 11        | Mono 1kHz 200% mod.<br>Pre-em. ON                                     |                                    | 15kLPF | 1/2        | —    | 0.15 | 0.5  | %     |
| 7   | Main S/N                            | SN <sub>main</sub>  | MONO | 11        | Mono 1kHz,<br>Pre-em. ON  | 20 log ('100%'/0%)                 | 15kLPF | 1/2        | 61   | 69   | —    | dB    |
| 8   | Sub output level                    | V <sub>sub</sub>    | ST   | 11        | SUB (L-R) 1kHz,<br>100% mod., NR OFF                                  |                                    |        | 17         | 150  | 190  | 230  | mVrms |
| 9   | Sub LPF frequency response          | FC <sub>sub</sub>   | ST   | 11        | SUB (L-R) 12kHz,<br>30% mod., NR OFF                                  | 20 log ('12k'/1k')                 |        | 17         | -3.0 | -0.5 | 1.0  | dB    |
| 10  | Sub distortion                      | THD <sub>sub</sub>  | ST   | 11        | SUB (L-R) 1kHz,<br>100% mod., NR OFF                                  |                                    | 15kLPF | 17         | —    | 0.1  | 1.0  | %     |
| 11  | Sub overload distortion             | THD <sub>smax</sub> | ST   | 11        | SUB (L-R) 1kHz,<br>200% mod., NR OFF                                  |                                    | 15kLPF | 17         | —    | 0.2  | 2.0  | %     |
| 12  | Sub S/N                             | SN <sub>sub</sub>   | ST   | 11        | SUB (L-R) 1kHz,<br>NR OFF   | 20 log ('100%'/0%)                 | 15kLPF | 17         | 56   | 64   | —    | dB    |
| 13  | Crosstalk Stereo → SAP              | CT <sub>st</sub>    | SAP  | 11        | ST-L (R) 1kHz,<br>100% mod., NR ON,<br>SAP Carrier (5f <sub>H</sub> ) | 20 log ('NRSW = 0'/<br>'NRSW = 1') | 1kBPFF | 2          | 60   | 70   | —    | dB    |
| 14  | Cross talk SAP → Stereo             | CT <sub>sap</sub>   | ST   | 11        | SAP 1kHz 100% mod.<br>NR ON, PILOT (f <sub>H</sub> )                  | 20 log ('NRSW = 1'/<br>'NRSW = 0') | 1kBPFF | 2          | 60   | 70   | —    | dB    |

(Ta = 25°C, Vcc = 9V)

| No. | Item                             | Symbol   | Mode | Input pin | Input signal                                | Measurement conditions             | Filter | Output pin | Min.  | Typ. | Max. | Unit  |
|-----|----------------------------------|----------|------|-----------|---|------------------------------------|--------|------------|-------|------|------|-------|
| 15  | Stereo ON level                  | THst     | ST   | 11        | Change PILOT (f <sub>H</sub> ) Level        | 0dB = 49mVrms                      |        | BUS RETURN | -9.0  | -6.0 | -3.0 | dB    |
| 16  | Stereo ON/OFF hysteresis         | HYst     |      |           |   | 20 log ('on level' / 'off level')  |        |            |       |      |      |       |
| 17  | SAP output level                 | Vsap     | SAP  | 11        | SAP 1kHz 100% mod. NR OFF                   |                                    |        | 20         | 130   | 160  | 190  | mVrms |
| 18  | SAP LPF frequency response       | FCsap    | SAP  | 11        | SAP 10kHz 30% mod. NR OFF                   | 20 log ('10k' / '1k')              |        | 20         | -3.0  | 0    | 2.5  | dB    |
| 19  | SAP distortion                   | THDsap   | SAP  | 11        | SAP 1kHz 100% mod. NR OFF                   |                                    | 15kLPF | 20         | —     | 2.5  | 6.0  | %     |
| 20  | SAP S/N                          | SNSap    | SAP  | 11        | SAP 1kHz, NR OFF                            | 20 log ('100%' / '0%')             | 15kLPF | 20         | 46    | 55   | —    | dB    |
| 21  | SAP ON level                     | THsap    | SAP  | 11        | Change SAP Carrier (5f <sub>H</sub> ) Level | 0dB = 147mVrms                     |        | BUS RETURN | -12.0 | -9.0 | -6.5 | dB    |
| 22  | SAP ON/OFF hysteresis            | HYsap    |      |           |   | 20 log ('on level' / 'off level')  |        |            |       |      |      |       |
| 23  | ST separation 1 L → R            | STLsep1  | ST   | 11        | ST-L 300Hz 30% mod. NR ON                   |                                    | 15kLPF | 1/2        | 23    | 35   | —    | dB    |
| 24  | ST separation 1 R → L            | STRsep1  | ST   | 11        | ST-R 300Hz 30% mod. NR ON                   |                                    | 15kLPF | 1/2        | 23    | 35   | —    | dB    |
| 25  | ST separation 2 L → R            | STLsep2  | ST   | 11        | ST-L 3kHz 30% mod. NR ON                    |                                    | 15kLPF | 1/2        | 23    | 35   | —    | dB    |
| 26  | ST separation 2 R → L            | STRsep2  | ST   | 11        | ST-R 3kHz 30% mod. NR ON                    |                                    | 15kLPF | 1/2        | 23    | 35   | —    | dB    |
| 27  | LSOUT output level               | Vls      | EXT  | 30/29     | Sine wave 1kHz 490mVrms                     | EXT1 = '1'                         |        | 1/2        | 440   | 490  | 540  | mVrms |
| 28  | LSOUT mute attenuation           | MUls     | EXT  | 30/29     | Sine wave 1kHz 490mVrms                     | EXT1 = '1' M1 = '0'                | 1kBPf  | 1/2        | —     | -90  | -80  | dB    |
| 29  | LSOUT distortion                 | THDls    | EXT  | 30/29     | Sine wave 1kHz 490mVrms                     | EXT1 = '1'                         | 15kLPF | 1/2        | —     | 0.01 | 0.3  | %     |
| 30  | LSOUT overload distortion        | THDlsmax | EXT  | 30/29     | Sine wave 1kHz 2Vrms                        | EXT1 = '1'                         | 15kLPF | 1/2        | —     | 0.03 | 0.3  | %     |
| 31  | LSOUT S/N                        | SNls     | EXT  | 30/29     | Sine wave 1kHz 490mVrms                     | EXT1 = '1'                         | 15kLPF | 1/2        | 80    | 88   | —    | dB    |
| 32  | LSOUT volume maximum attenuation | VOLmin   | EXT  | 30/29     | Sine wave 1kHz 490mVrms                     | EXT1 = '1' VOL-L = '0' VOL-R = '0' | 1kBPf  | 1/2        | —     | -90  | -80  | dB    |

Electrical Characteristics Measurement Circuit

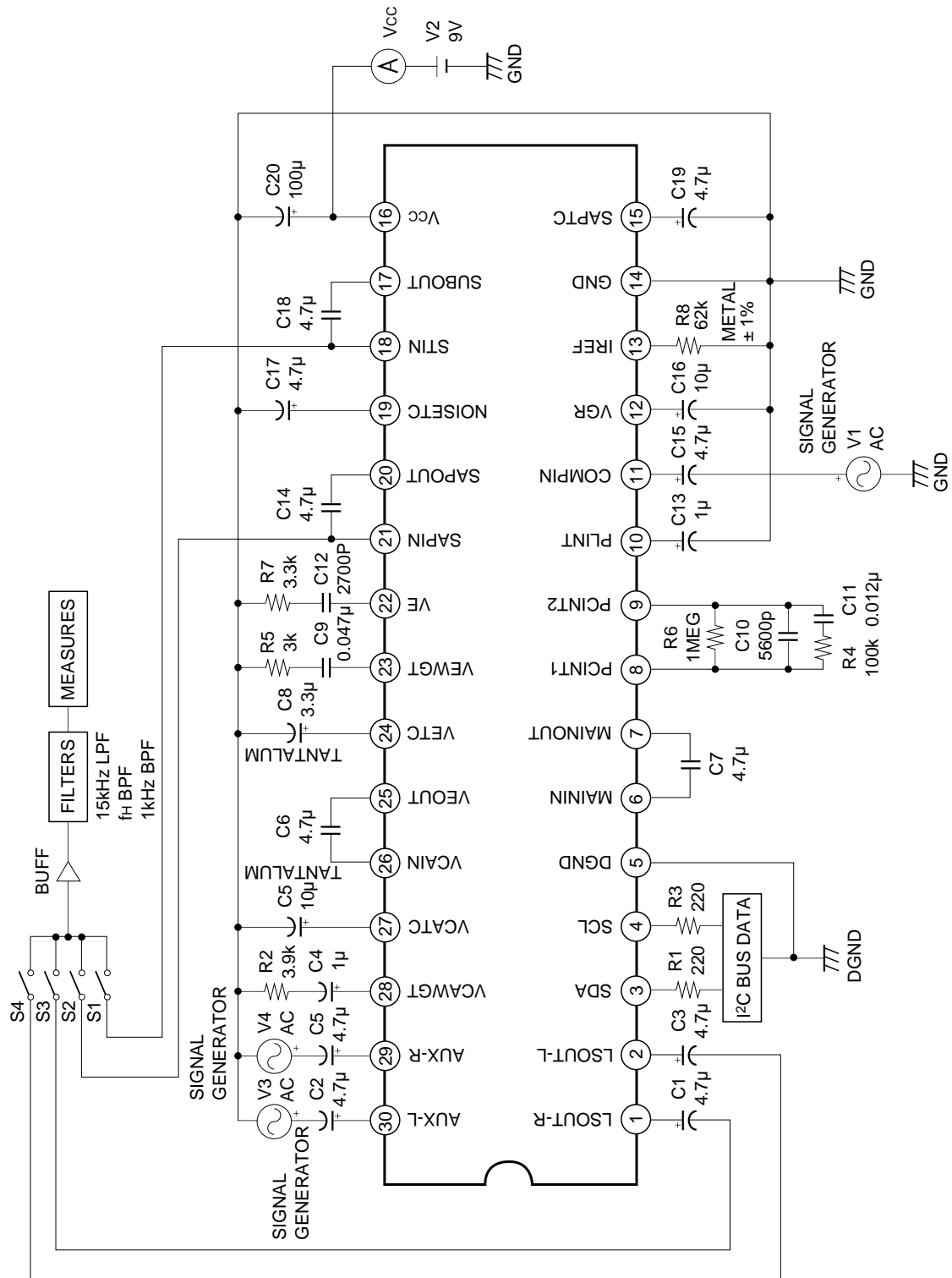



**Register Specifications**

**Slave address**

|                 |                   |
|-----------------|-------------------|
| SLAVE RECEIVER  | SLAVE TRANSMITTER |
| 84H (1000 0100) | 85H (1000 0101)   |

**Register table**

| SUB ADDRESS |     | DATA |      |          |       |      |      |      |      |
|-------------|-----|------|------|----------|-------|------|------|------|------|
| MSB         | LSB | BIT7 | BIT6 | BIT5     | BIT4  | BIT3 | BIT2 | BIT1 | BIT0 |
| ****0000    |     | *    |      | TEST-DA  | TEST1 | ATT  |      |      |      |
| ****0001    |     | *    |      | SPECTRAL |       |      |      |      |      |
| ****0010    |     | *    |      | WIDEBAND |       |      |      |      |      |
| ****0011    |     | *    |      | EXT1     | *     | NRSW | FOMO | SAPC | M1   |
| ****0100    |     | *    |      | VOL-L    |       |      |      |      |      |
| ****0101    |     | *    |      | VOL-R    |       |      |      |      |      |

\* : don't care

**Status Registers**

|                |        |      |       |      |      |      |      |
|----------------|--------|------|-------|------|------|------|------|
| STA1           | STA2   | STA3 | STA4  | STA5 | STA6 | STA7 | STA8 |
| BIT7           | BIT6   | BIT5 | BIT4  | BIT3 | BIT2 | BIT1 | BIT0 |
| POWER ON RESET | STEREO | SAP  | NOISE | —    | —    | —    | —    |

**Note)** The micro computer reads both SAP and NOISE status and judges SAP discrimination.

## Description of Registers

### Control registers

| Register | Number of bits | Classification*1 | Standard setting | Contents   |
|----------|----------------|------------------|------------------|--|
| ATT      | 4              | A                | 9                | Input level adjustment   |
| SPECTRAL | 6              | A                | 1F               | Adjustment of stereo separation (3kHz)   |
| WIDEBAND | 6              | A                | 1F               | Adjustment of stereo separation (300Hz)  |
| TEST-DA  | 1              | T                | 0                | DAC test mode  |
| TEST1    | 1              | T                | 0                | Test mode  |
| EXT1     | 1              | U                | 0                | Selection of TV mode or external input mode                                    |
| NRSW     | 1              | U                | 0                | Selection of the output signal (Stereo mode, SAP mode)                         |
| FOMO     | 1              | U                | 0                | Forced MONO<br>(Left channel only is MONO during SAP output.)                  |
| M1       | 1              | U                | 1                | Selection of LSOUT mute function ON/OFF<br>(0: mute ON, 1: mute OFF)           |
| SAPC     | 1              | S                | 0                | Selection SAP mode or L + R mode according to the presence of SAP broadcasting |
| VOL-L    | 1              | U                | 3F               | Left channel volume control  |
| VOL-R    | 1              | U                | 3F               | Right channel volume control   |

\*1 Classification U: User control  
 A: Adjustment  
 S: Proper to set  
 T: Test

### Status registers

| Register | Number of bits | Contents  |
|----------|----------------|---|
| PONRES   | 1              | POWER ON RESET detection; 1: RESET                          |
| STEREO   | 1              | Stereo discrimination of the COMPIN input signal; 1: Stereo |
| SAP      | 1              | SAP discrimination of the COMPIN input signal; 1: SAP       |
| NOISE    | 1              | Noise level discrimination of the SAP signal; 1: Noise      |

### Description of Control Registers

|          |      |  |
|----------|------|--|
| ATT      | (4): | Perform input level adjustment.<br>0 = Level min.<br>F = Level max.  |
| SPECTRAL | (6): | Perform high frequency (fs = 3kHz) separation adjustment.<br>0 = Level max.<br>3F = Level min.   |
| WIDEBAND | (6): | Perform low frequency (fs = 300Hz) separation adjustment.<br>0 = Level min.<br>3F = Level max.   |
| TEST-DA  | (1): | Set DAC output test mode.<br>0 = Normal mode<br>1 = DAC output test mode<br>In addition, the following output are present at Pin 2.<br>LSOUT-L (Pin 2): DA control DC level                                      |
| TEST1    | (1): | Monitor SAPBPF and NRBPF output<br>0 = Normal mode<br>1 = SAPBPF, NRBPF output<br>In addition, the following outputs are present at Pins 1 and 2.<br>LSOUT-L (Pin 2): SAP BPF OUT<br>LSOUT-R (Pin 1): NR BPF OUT |
| EXT1     | (1): | Select TV mode or external input mode<br>0 = TV mode<br>1 = External input mode  |
| NRSW     | (1): | Select stereo mode or SAP mode<br>0 = Stereo mode<br>1 = SAP mode  |
| FOMO     | (1): | Select forced MONO mode<br>0 = Normal mode<br>1 = Forced MONO mode   |
| M1       | (1): | Mute the LSOUT-L and LSOUT-R output.<br>0 = Mute ON<br>1 = Mute OFF  |

- SAPC (1): Select the SAP signal output mode  
When there is no SAP signal, the conditions for selecting SAP output are selected by SAPC.  
0 = L + R output is selected  
1 = SAP output is selected
- VOL-L (6): LSOUT-L output signal level control  
0 = Volume min.  
3F = Volume max.  
-1.25dB/STEP
- VOL-R (6): LSOUT-R output signal level control  
0 = Volume min.  
3F = Volume max.  
-1.25dB/STEP

**Description of Mode Control**

| Mode control | SAPC = 0   | SAPC = 1  |
|--------------|--|---|
| NRSW         | <p>“Select dbx input and TV decoder output”</p> <p>Conditions: FOMO = 0</p> <p>NRSW = 0 (MONO or ST output)</p> <ul style="list-style-type: none"> <li>• During ST input: left channel: L, right channel: R</li> <li>• During other input: left channel: L + R, right channel: L + R</li> </ul> <p>NRSW = 1 (SAP output)</p> <ul style="list-style-type: none"> <li>• When there is “SAP” during SAP discrimination<br/>– left channel: SAP, right channel: SAP</li> <li>• When there is “No SAP”, output is the same as when NRSW = 0.</li> </ul> | <p>“Select dbx input and TV decoder output”</p> <p>Conditions: FOMO = 0</p> <p>NRSW = 0 (MONO or ST output)<br/>As on the left</p> <p>NRSW = 1 (SAP output)</p> <ul style="list-style-type: none"> <li>• Regardless of the presence of SAP discrimination, dbx input: “SAP”<br/>left channel: SAP, right channel: SAP</li> </ul> <p>However, when there is no SAP, SAPOUT output is soft muted (–7dB)</p> |
| FOMO         | <p>“Forced MONO”</p> <p>FOMO = 1</p> <ul style="list-style-type: none"> <li>• During SAP output: left channel: L + R, right channel: SAP</li> <li>• During ST or MONO output: left channel: L + R, right channel: L + R</li> </ul>   |   |
| SAPC         | <p>Change the selection conditions for “MONO or ST output” and “SAP output”.</p> <p>SAPC = 0: Switch to SAP output when there is SAP discrimination.<br/>Do not switch to SAP output when there is no SAP discrimination.</p> <p>SAPC = 1: Switch to SAP output regardless of whether there is SAP discrimination.</p>   |   |
| M1           | <p>“MUTE”</p> <p>M1 = 0: LSOUT output is muted.</p>  |   |

Decoder Output and Mode Control Table 1 (SAPC = 1)

| Input signal mode | Mode detection |     |       | Mode control |      |      | dbx input | Output |       |
|-------------------|----------------|-----|-------|--------------|------|------|-----------|--------|-------|
|                   | ST             | SAP | NOISE | NRSW         | FOMO | SAPC |           | Lch    | Rch   |
| MONO *1           | 0              | 0   | 0     | 0            | *    | 1    | MUTE      | L + R  | L + R |
|                   | 0              | 0   | 0     | 1            | 0    | 1    | SAP       | SAP    | SAP   |
|                   | 0              | 0   | 0     | 1            | 1    | 1    | SAP       | L + R  | SAP   |
|                   | 0              | *   | 1     | 0            | *    | 1    | MUTE      | L + R  | L + R |
|                   | 0              | *   | 1     | 1            | 0    | 1    | (SAP)     | (SAP)  | (SAP) |
|                   | 0              | *   | 1     | 1            | 1    | 1    | (SAP)     | L + R  | (SAP) |
| STEREO *1         | 1              | 0   | *     | 0            | 0    | 1    | L - R     | L      | R     |
|                   | 1              | 0   | *     | 0            | 1    | 1    | MUTE      | L + R  | L + R |
|                   | 1              | 1   | 1     | 0            | 0    | 1    | L - R     | L      | R     |
|                   | 1              | 1   | 1     | 0            | 1    | 1    | MUTE      | L + R  | L + R |
|                   | 1              | 0   | 0     | 1            | 0    | 1    | SAP       | SAP    | SAP   |
|                   | 1              | 0   | 0     | 1            | 1    | 1    | SAP       | L + R  | SAP   |
|                   | 1              | *   | 1     | 1            | 0    | 1    | (SAP)     | (SAP)  | (SAP) |
|                   | 1              | *   | 1     | 1            | 1    | 1    | (SAP)     | L + R  | (SAP) |
| MONO & SAP        | 0              | 1   | *     | 0            | 0    | 1    | MUTE      | L + R  | L + R |
|                   | 0              | 1   | *     | 0            | 1    | 1    | MUTE      | L + R  | L + R |
|                   | 0              | 1   | 0     | 1            | 0    | 1    | SAP       | SAP    | SAP   |
|                   | 0              | 1   | 0     | 1            | 1    | 1    | SAP       | L + R  | SAP   |
|                   | 0              | 1   | 1     | 1            | 0    | 1    | (SAP)     | (SAP)  | (SAP) |
|                   | 0              | 1   | 1     | 1            | 1    | 1    | (SAP)     | L + R  | (SAP) |
| STEREO & SAP      | 1              | 1   | *     | 0            | 0    | 1    | L - R     | L      | R     |
|                   | 1              | 1   | *     | 0            | 1    | 1    | MUTE      | L + R  | L + R |
|                   | 1              | 1   | 0     | 1            | 0    | 1    | SAP       | SAP    | SAP   |
|                   | 1              | 1   | 0     | 1            | 1    | 1    | SAP       | L + R  | SAP   |
|                   | 1              | 1   | 1     | 1            | 0    | 1    | (SAP)     | (SAP)  | (SAP) |
|                   | 1              | 1   | 1     | 1            | 1    | 1    | (SAP)     | L + R  | (SAP) |

**Note**

(SAP) : The SAPOUT output signal is soft muted (approximately -7dB).

The signal is soft muted when NOISE = 1.

\* : Don't care.

\*1 SAP or NOISE discrimination may be made during MONO or STEREO input when the noise is inputted in the weak electric field.

Then microcomputer reads "NOISE" status from IC and decides whether SAP is outputted.

"NOISE" status rises earlier than "SAP" status when the amount of noise is increased to COMPIN.

Decoder Output and Mode Control Table 2 (SAPC = 0)

| Input signal mode | Mode detection |     |       | Mode control |      |      | dbx input | Output |       |
|-------------------|----------------|-----|-------|--------------|------|------|-----------|--------|-------|
|                   | ST             | SAP | NOISE | NRSW         | FOMO | SAPC |           | Lch    | Rch   |
| MONO *1           | 0              | 0   | *     | *            | *    | 0    | MUTE      | L + R  | L + R |
|                   | 0              | 1   | 1     | 0            | 0    | 0    | MUTE      | L + R  | L + R |
|                   | 0              | 1   | 1     | 0            | 1    | 0    | MUTE      | L + R  | L + R |
|                   | 0              | 1   | 1     | 1            | 0    | 0    | (SAP)     | (SAP)  | (SAP) |
|                   | 0              | 1   | 1     | 1            | 1    | 0    | (SAP)     | L + R  | (SAP) |
| STEREO *1         | 1              | 0   | *     | 0            | 0    | 0    | L - R     | L      | R     |
|                   | 1              | 0   | *     | 0            | 1    | 0    | MUTE      | L + R  | L + R |
|                   | 1              | 0   | *     | 1            | 0    | 0    | L - R     | L      | R     |
|                   | 1              | 0   | *     | 1            | 1    | 0    | MUTE      | L + R  | L + R |
|                   | 1              | 1   | 1     | 0            | 0    | 0    | L - R     | L      | R     |
|                   | 1              | 1   | 1     | 0            | 1    | 0    | MUTE      | L + R  | L + R |
|                   | 1              | 1   | 1     | 1            | 0    | 0    | (SAP)     | (SAP)  | (SAP) |
|                   | 1              | 1   | 1     | 1            | 1    | 0    | (SAP)     | L + R  | (SAP) |
| MONO & SAP        | 0              | 1   | 0     | 0            | 0    | 0    | MUTE      | L + R  | L + R |
|                   | 0              | 1   | 0     | 0            | 1    | 0    | MUTE      | L + R  | L + R |
|                   | 0              | 1   | 0     | 1            | 0    | 0    | SAP       | SAP    | SAP   |
|                   | 0              | 1   | 0     | 1            | 1    | 0    | SAP       | L + R  | SAP   |
|                   | 0              | 1   | 1     | 0            | 0    | 0    | MUTE      | L + R  | L + R |
|                   | 0              | 1   | 1     | 0            | 1    | 0    | MUTE      | L + R  | L + R |
|                   | 0              | 1   | 1     | 1            | 0    | 0    | (SAP)     | (SAP)  | (SAP) |
|                   | 0              | 1   | 1     | 1            | 1    | 0    | (SAP)     | L + R  | (SAP) |
| STEREO & SAP      | 1              | 1   | 0     | 0            | 0    | 0    | L - R     | L      | R     |
|                   | 1              | 1   | 0     | 0            | 1    | 0    | MUTE      | L + R  | L + R |
|                   | 1              | 1   | 0     | 1            | 0    | 0    | SAP       | SAP    | SAP   |
|                   | 1              | 1   | 0     | 1            | 1    | 0    | SAP       | L + R  | SAP   |
|                   | 1              | 1   | 1     | 0            | 0    | 0    | L - R     | L      | R     |
|                   | 1              | 1   | 1     | 0            | 1    | 0    | MUTE      | L + R  | L + R |
|                   | 1              | 1   | 1     | 1            | 0    | 0    | (SAP)     | (SAP)  | (SAP) |
|                   | 1              | 1   | 1     | 1            | 1    | 0    | (SAP)     | L + R  | (SAP) |

**Note**

(SAP) : The SAPOUT output signal is soft muted (approximately -7dB).

The signal is soft muted when NOISE = 1.

\* : Don't care.

\*1 SAP or NOISE discrimination may be made during MONO or STEREO input when the noise is inputted in the weak electric field.

Then microcomputer reads "NOISE" status from IC and decides whether SAP is outputted.

"NOISE" status rises earlier than "SAP" status when the amount of noise is increased to COMPIN.

**Description of Operation**

The US audio multiplexing system possesses the base band spectrum shown in Fig. 1.

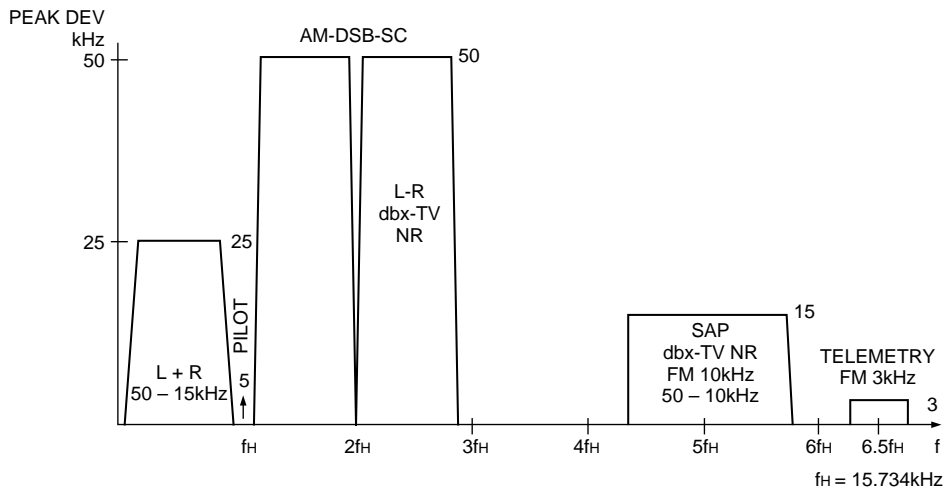

**Fig. 1. Base band spectrum**

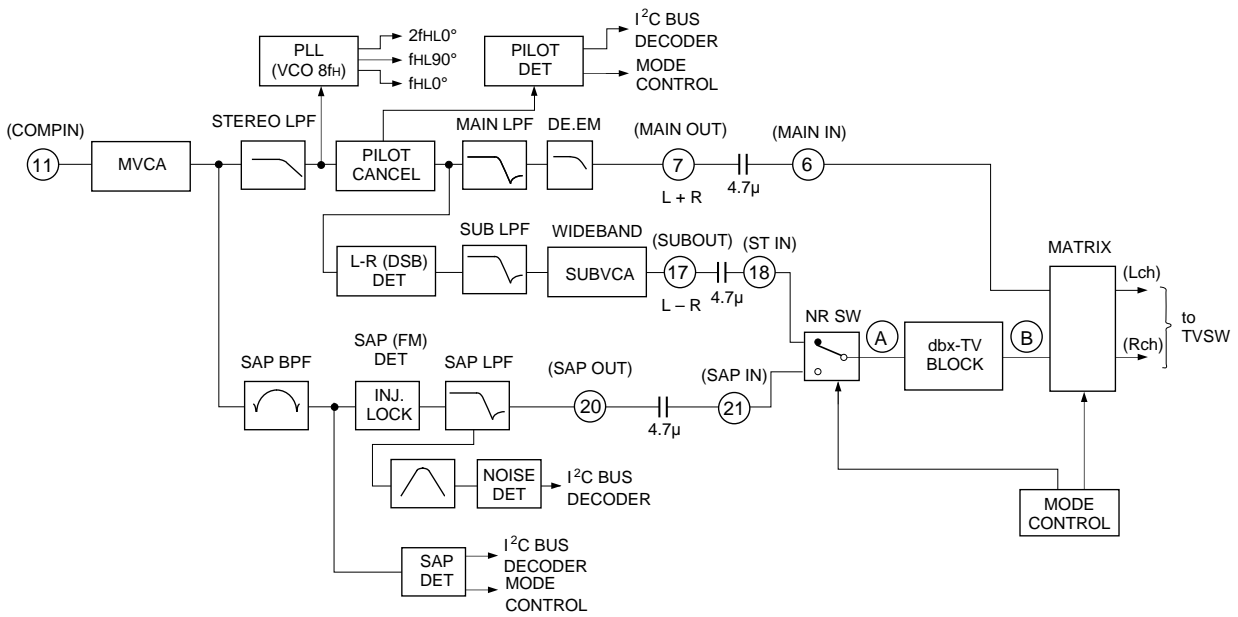

**Fig. 2. Overall block diagram (See Fig. 3 for the dbx-TV block)**

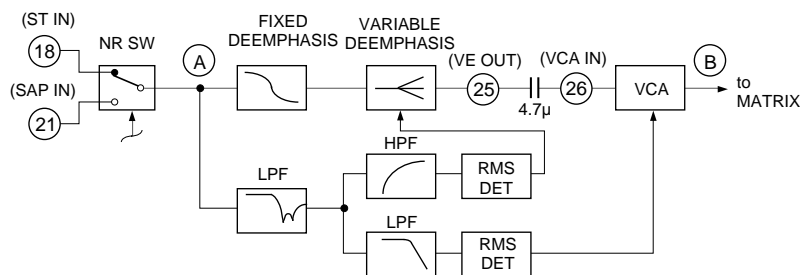

**Fig 3. dbx-TV block**

(1) L + R (MAIN)

After the audio multiplexing signal input from COMPIN (Pin 11) passes through MVCA, the SAP signal and telemetry signal are suppressed by STEREO LPF. Next, the pilot signals are canceled. Finally, the L – R signal and SAP signal are removed by MAIN LPF, and frequency characteristics are flattened (de-emphasized) and input to the matrix.

(2) L – R (SUB)

The L – R signal follows the same course as L + R before the pilot signal is canceled. L – R has no carrier signal, as it is a suppressed-carrier double-sideband amplitude modulated signal (DSB-AM modulated). For this reason, the pilot signal is used to regenerate the carrier signal (quasi-sine wave) to be used for the demodulation of the L – R signal. In the last stage, the residual high frequency components are removed by SUB LPF and the L – R signal is input to the dbx-TV block via the NRSW circuit after passing through SUBVCA.

(3) SAP

SAP is an FM signal using 5fH as a carrier as shown in the Fig. 1. First, the SAP signal only is extracted using SAP BPF. Then, this is subjected to FM detection. Finally, residual high frequency components are removed and frequency characteristics flattened using SAP LPF, and the SAP signal is input to the dbx-TV block via the NRSW circuit. When there is no SAP signal, the Pin 20 output is soft muted.

(4) Mode discrimination

Stereo discrimination is performed by detecting the pilot signal amplitude. SAP discrimination is performed by detecting the 5fH carrier amplitude. NOISE discrimination is performed by detecting the noise near 25kHz after FM detection of SAP signal.

(5) dbx-TV block

Either the L – R signal or SAP signal input respectively from ST IN (Pin 18) or SAP IN (Pin 21) is selected by the mode control and input to the dbx-TV block.

The input signal then passes through the fixed de-emphasis circuit and is applied to the variable de-emphasis circuit. The signal output from the variable de-emphasis circuit passes through an external capacitor and is applied to VCA (voltage control amplifier). Finally, the VCA output is converted from a current to a voltage using an operational amplifier and then input to the matrix.

The variable de-emphasis circuit transmittance and VCA gain are respectively controlled by Each of effective value detection circuits. Each of the effective value detection circuits passes the input signal through a predetermined filter for weighting before the effective value of the weighted signal is detected to provide the control signal.

(6) Matrix, TVSW

The signals (L + R, L – R, SAP) input to "MATRIX" become the outputs for the ST-L, ST-R, MONO and SAP signals according to the mode control and whether there is ST / SAP discrimination.

"TVSW" switches the "MATRIX" output signal and external input signal.

(7) Others

"MVCA" is a VCA which adjusts the input signal level to the standard level of this IC.

"Bias" supplies the reference voltage and reference current to the other blocks. The current flowing to the resistor connecting IREF (Pin 13) with GND become the reference current.

Application Circuit

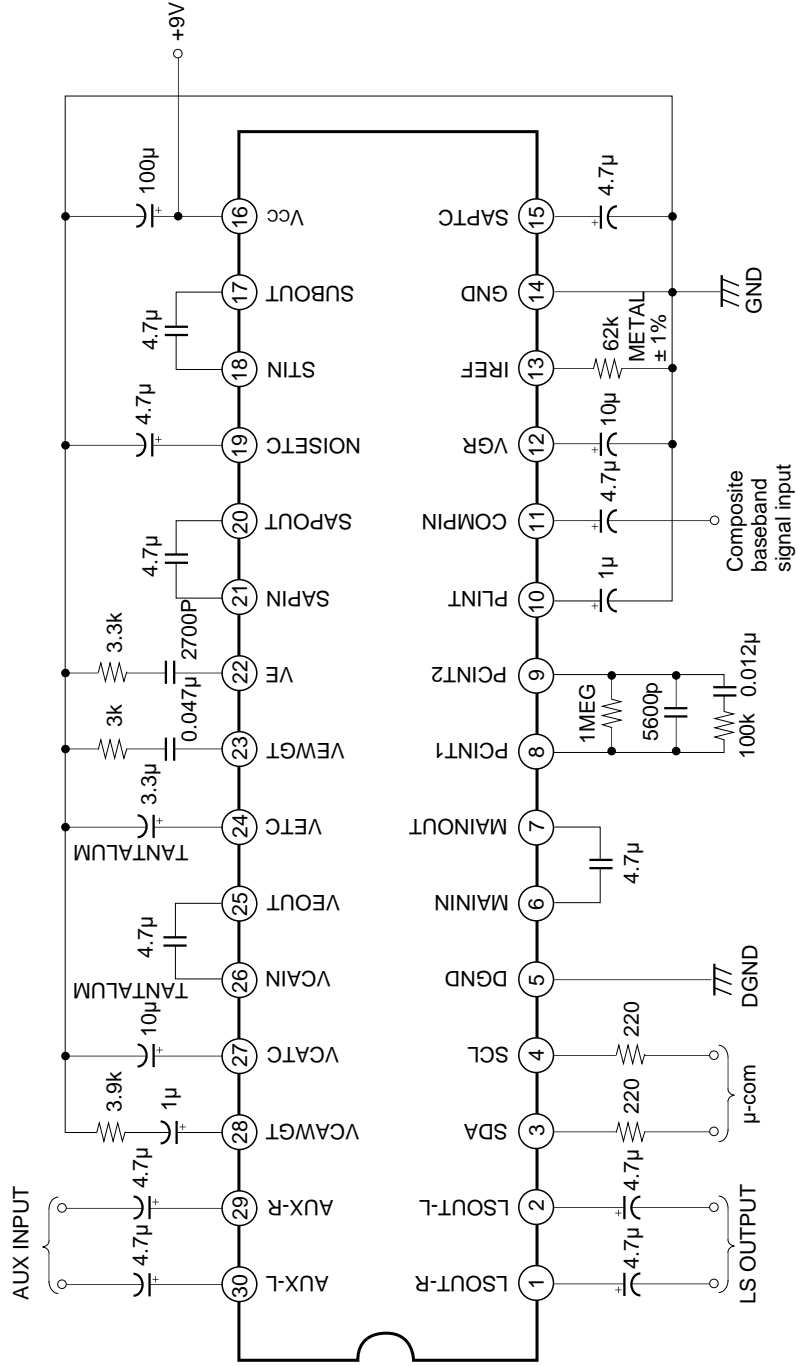

Application circuits shown are typical examples illustrating the operation of the devices. Sony cannot assume responsibility for any problems arising out of the use of these circuits or for any infringement of third party patent and other right due to same.

I<sup>2</sup>C BUS block items (SDA, SCL)

| No. | Item   | Symbol               | Min. | Typ. | Max. | Unit |
|-----|--|----------------------|------|------|------|------|
| 1   | High level input voltage                               | V <sub>IH</sub>      | 3.0  | —    | 5.0  | V    |
| 2   | Low level input voltage                                | V <sub>IL</sub>      | 0    | —    | 1.5  |      |
| 3   | High level input current                               | I <sub>IH</sub>      | —    | —    | 10   | μA   |
| 4   | Low level input current                                | I <sub>IL</sub>      | —    | —    | 10   |      |
| 5   | Low level output voltage SDA (Pin 3) during 3mA inflow | V <sub>OL</sub>      | 0    | —    | 0.4  | V    |
| 6   | Maximum inflow current                                 | I <sub>OL</sub>      | 3    | —    | —    | mA   |
| 7   | Input capacitance                                      | C <sub>I</sub>       | —    | —    | 10   | pF   |
| 8   | Maximum clock frequency                                | f <sub>SCL</sub>     | 0    | —    | 100  | kHz  |
| 9   | Minimum waiting time for data change                   | t <sub>BUF</sub>     | 4.7  | —    | —    | μs   |
| 10  | Minimum waiting time for start of data transfer        | t <sub>HD: STA</sub> | 4.0  | —    | —    |      |
| 11  | Low level clock pulse width                            | t <sub>LOW</sub>     | 4.7  | —    | —    |      |
| 12  | High level clock pulse width                           | t <sub>HIGH</sub>    | 4.0  | —    | —    |      |
| 13  | Minimum waiting time for start preparation             | t <sub>SU: STA</sub> | 4.7  | —    | —    |      |
| 14  | Minimum data hold time                                 | t <sub>HD: DAT</sub> | 0    | —    | —    |      |
| 15  | Minimum data preparation time                          | t <sub>SU: DAT</sub> | 250  | —    | —    | ns   |
| 16  | Rise time  | t <sub>R</sub>       | —    | —    | 1    | μs   |
| 17  | Fall time  | t <sub>F</sub>       | —    | —    | 300  | ns   |
| 18  | Minimum waiting time for stop preparation              | t <sub>SU: STO</sub> | 4.7  | —    | —    | μs   |

I<sup>2</sup>C BUS load conditions: Pull-up resistor 4kΩ (Connect to +5V)  
 Load capacity 200pF (Connect to GND)

I<sup>2</sup>C BUS Control Signal

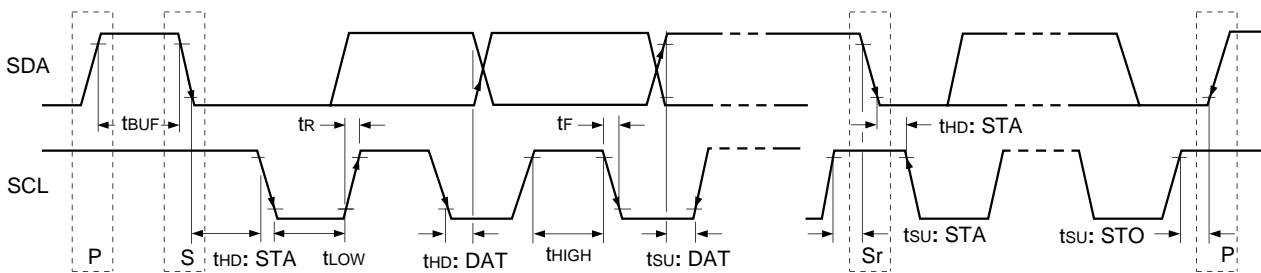

**I<sup>2</sup>C BUS Signal**

There are two I<sup>2</sup>C signals, SDA (Serial DATA) and SCL (Serial CLOCK) signals. SDA is a bidirectional signal.

- Accordingly there are 3 values outputs, H, L and Hi-Z.

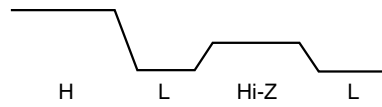

- I<sup>2</sup>C transfer begins with Start Condition S and ends with Stop Condition P.

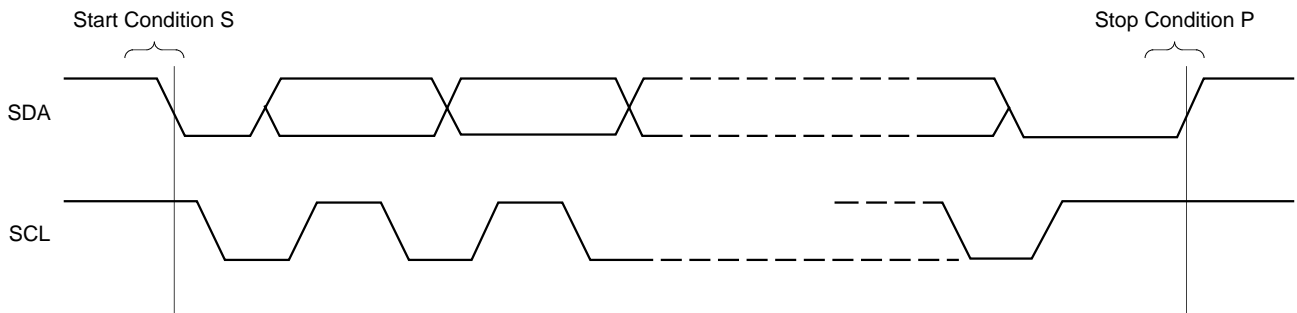

• I<sup>2</sup>C data Write (Write from I<sup>2</sup>C controller to the IC)

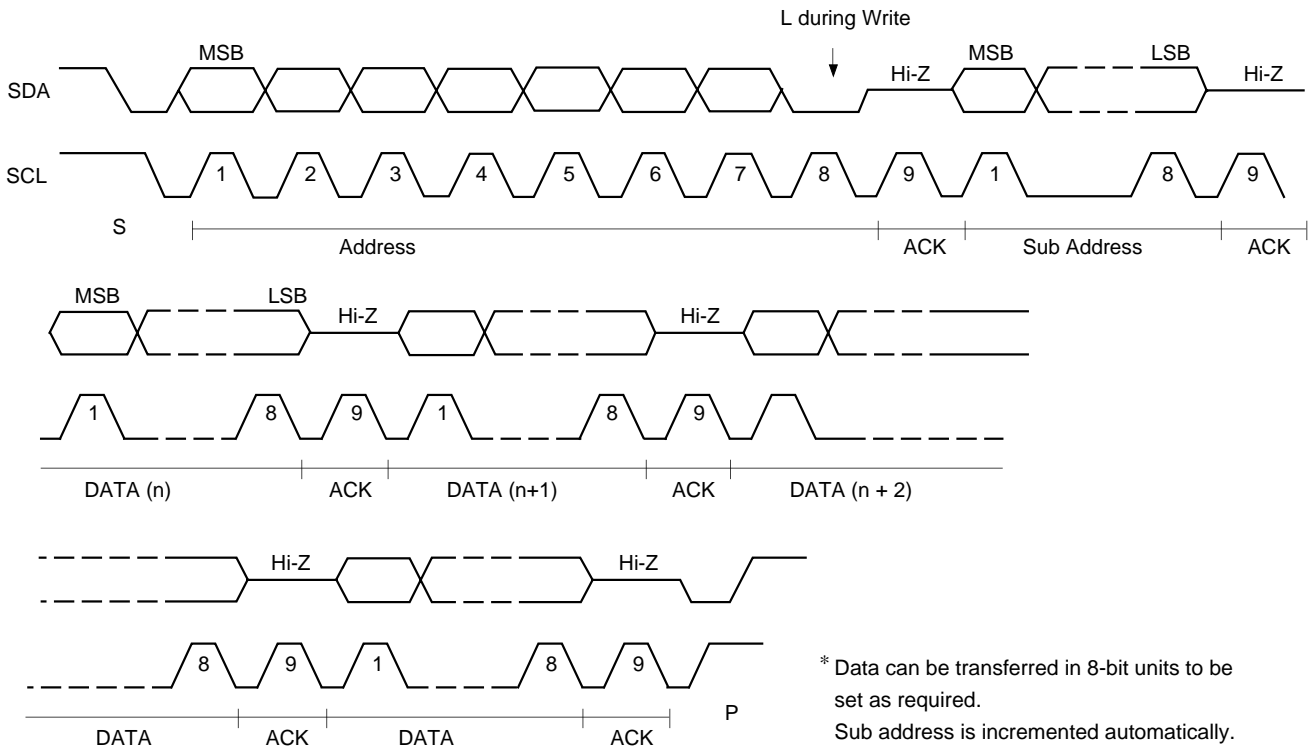

• I<sup>2</sup>C data Read (Read from the IC to I<sup>2</sup>C controller)

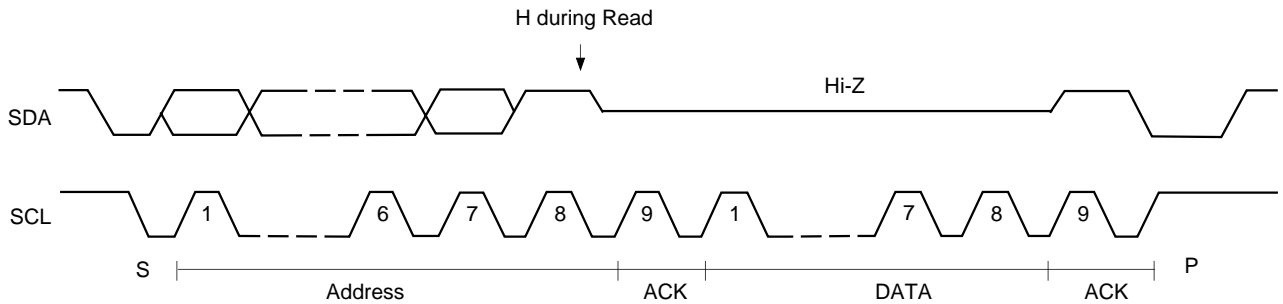

• Read timing

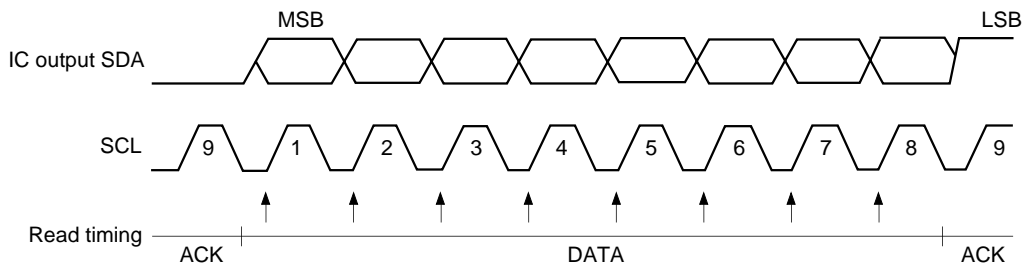

\* Data Read is performed during SCL rise.

**Input level vs. Distortion characteristics 1 (MONO)**

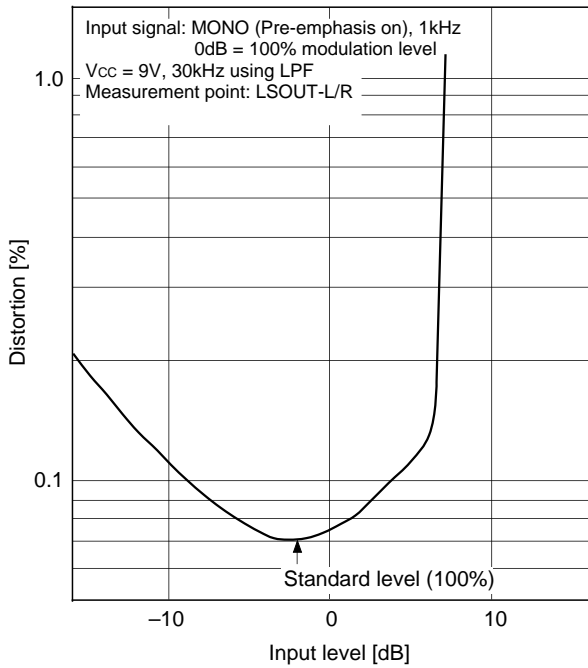

**Input level vs. Distortion characteristics 2 (Stereo)**

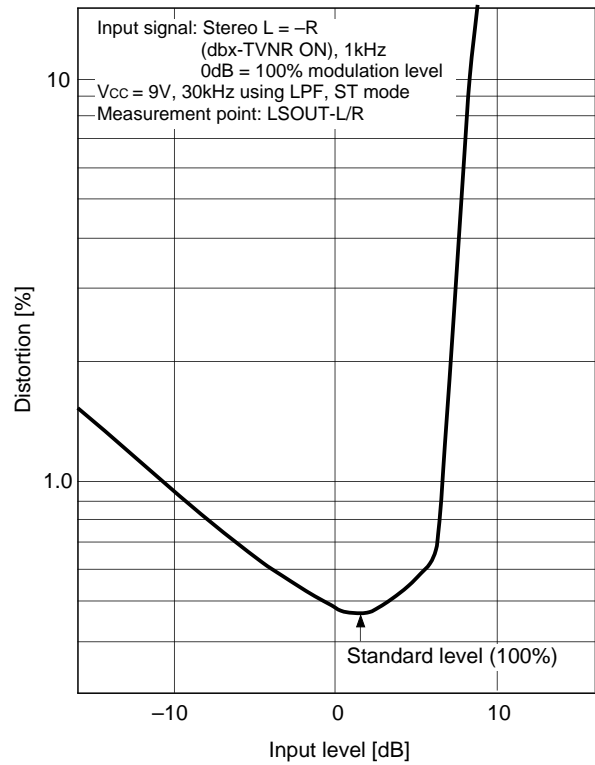

**Input level vs. Distortion characteristics 3 (SAP)**

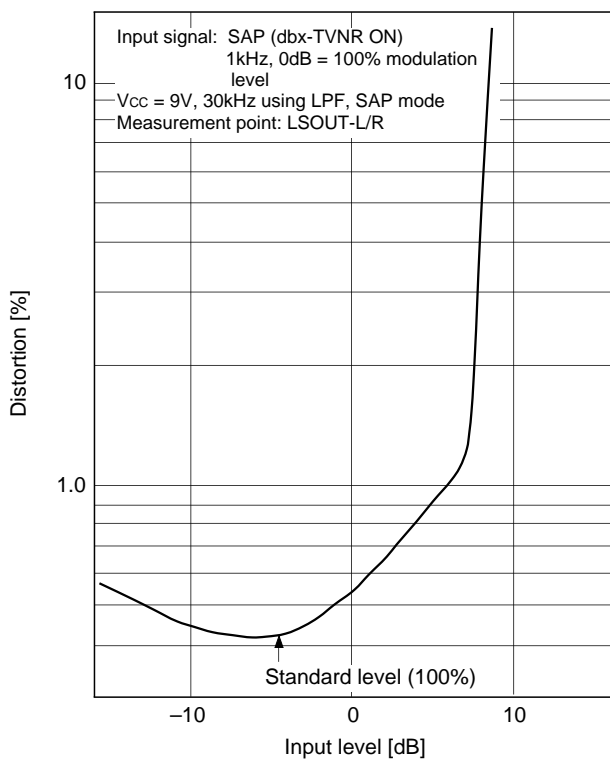

**Stereo LPF frequency characteristics**

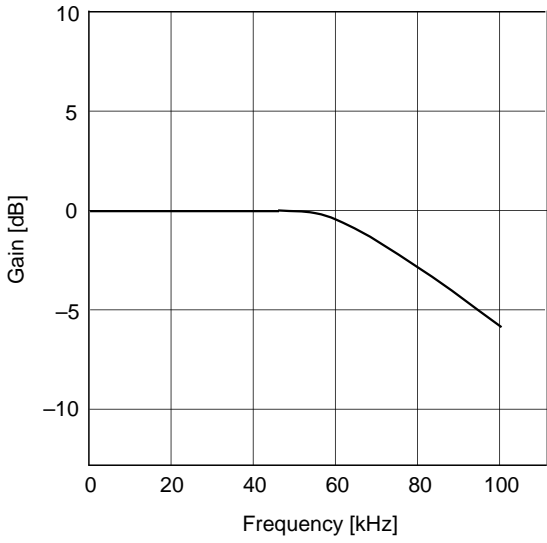

**Main LPF and Sub LPF frequency characteristics**

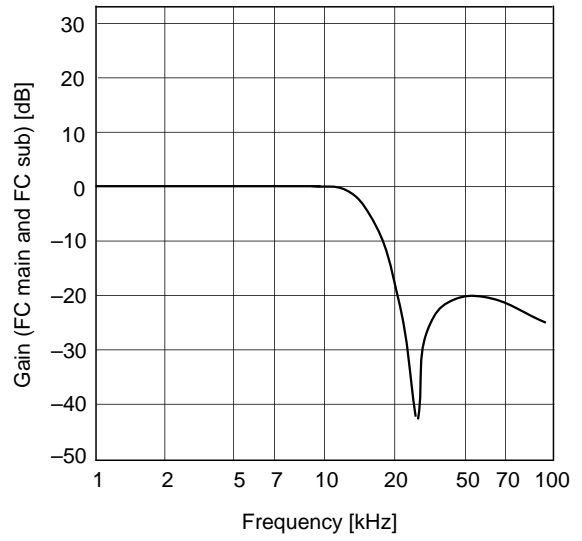

**SAP frequency characteristics and group delay**

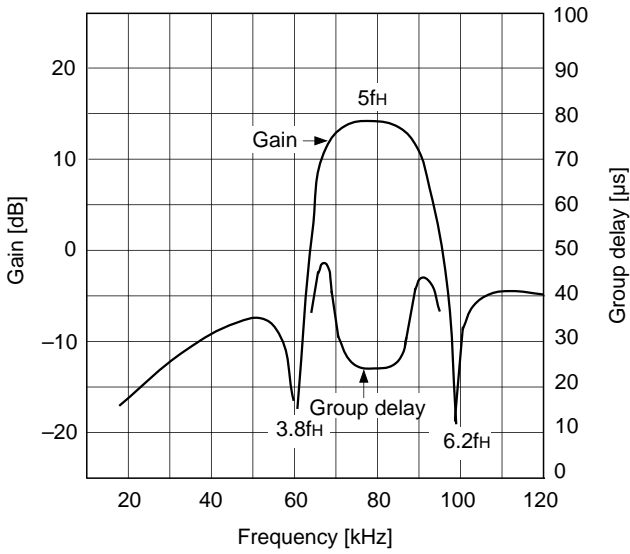

**Volume characteristics**

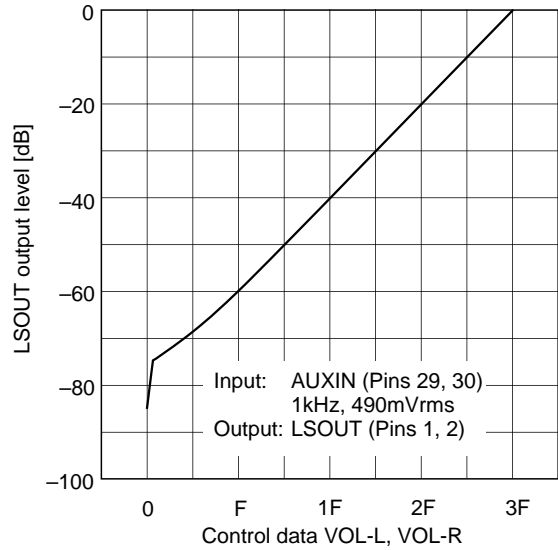

Package Outline Unit: mm

30PIN SDIP (PLASTIC)

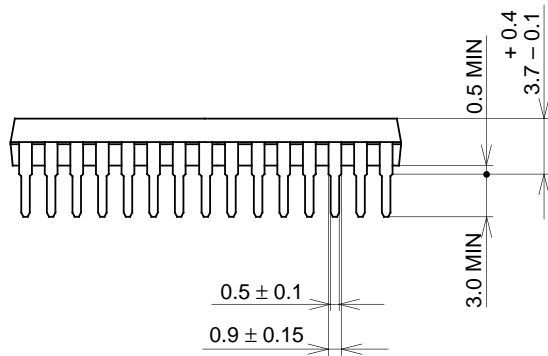
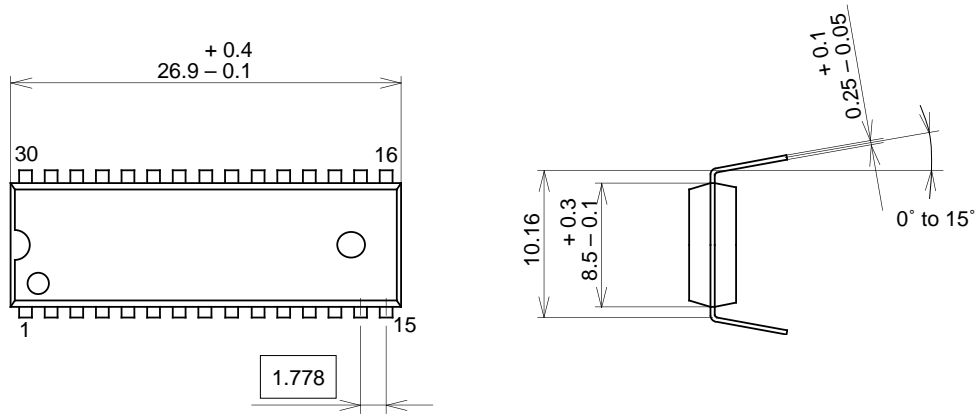

Two kinds of package surface:  
 1. All mat surface type.  
 2. All mirror surface type.

PACKAGE STRUCTURE

|            |                         |
|------------|-------------------------|
| SONY CODE  | SDIP-30P-01             |
| EIAJ CODE  | P-SDIP30-8.5x26.9-1.778 |
| JEDEC CODE | _____                   |

|                  |                   |
|------------------|-------------------|
| MOLDING COMPOUND | EPOXY RESIN       |
| LEAD TREATMENT   | PALLADIUM PLATING |
| LEAD MATERIAL    | COPPER ALLOY      |
| PACKAGE MASS     | 1.8g              |



LittleDiode supplies new, hard to find or obsolete electronic components and semiconductors all over the world.

With over two million different components listed you are sure to find the part you need.

Feel free to visit us today at our online store:

[LittleDiode.com](http://LittleDiode.com)

Looking forward to providing you with the best possible service.