

Digital CCD Camera Head Amplifier

Description

The CXA2096N is a bipolar IC developed as a head amplifier for digital CCD cameras. This IC provides the following functions: correlated double sampling, AGC for the CCD signal, A/D sample and hold, blanking, A/D reference voltage, and an output driver.

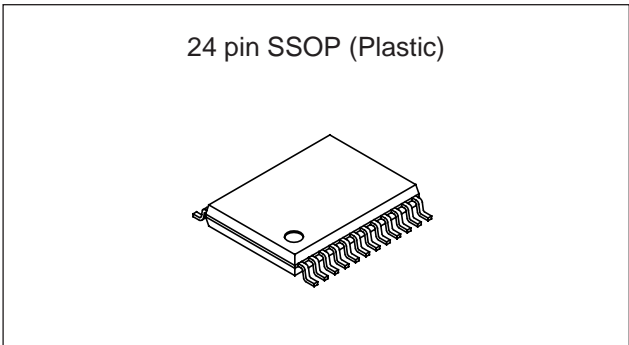

Features

- High sensitivity made possible by a high-gain AGC amplifier
- Blanking function provided for the purpose of calibrating the CCD output signal black level
- Regulator output pin provided for A/D converter reference voltage
- Built-in sample-and-hold circuits for camera signals required by external A/D converters

Absolute Maximum Ratings

| | | | |
|-------------------------------|------------------|-------------|----|
| • Supply voltage | V _{CC} | 11 | V |
| • Operating temperature | T _{opr} | -20 to +75 | °C |
| • Storage temperature | T _{stg} | -65 to +150 | °C |
| • Allowable power dissipation | P _D | 417 | mW |

Operating Conditions

| | | | |
|----------------|------------------------|------------|---|
| Supply voltage | V _{CC1, 2, 3} | 3.0 to 3.6 | V |
|----------------|------------------------|------------|---|

Applications

DVC/still cameras for consumer use

Structure

Bipolar silicon monolithic IC

Sony reserves the right to change products and specifications without prior notice. This information does not convey any license by any implication or otherwise under any patents or other right. Application circuits shown, if any, are typical examples illustrating the operation of the devices. Sony cannot assume responsibility for any problems arising out of the use of these circuits.

Block Diagram and Pin Configuration

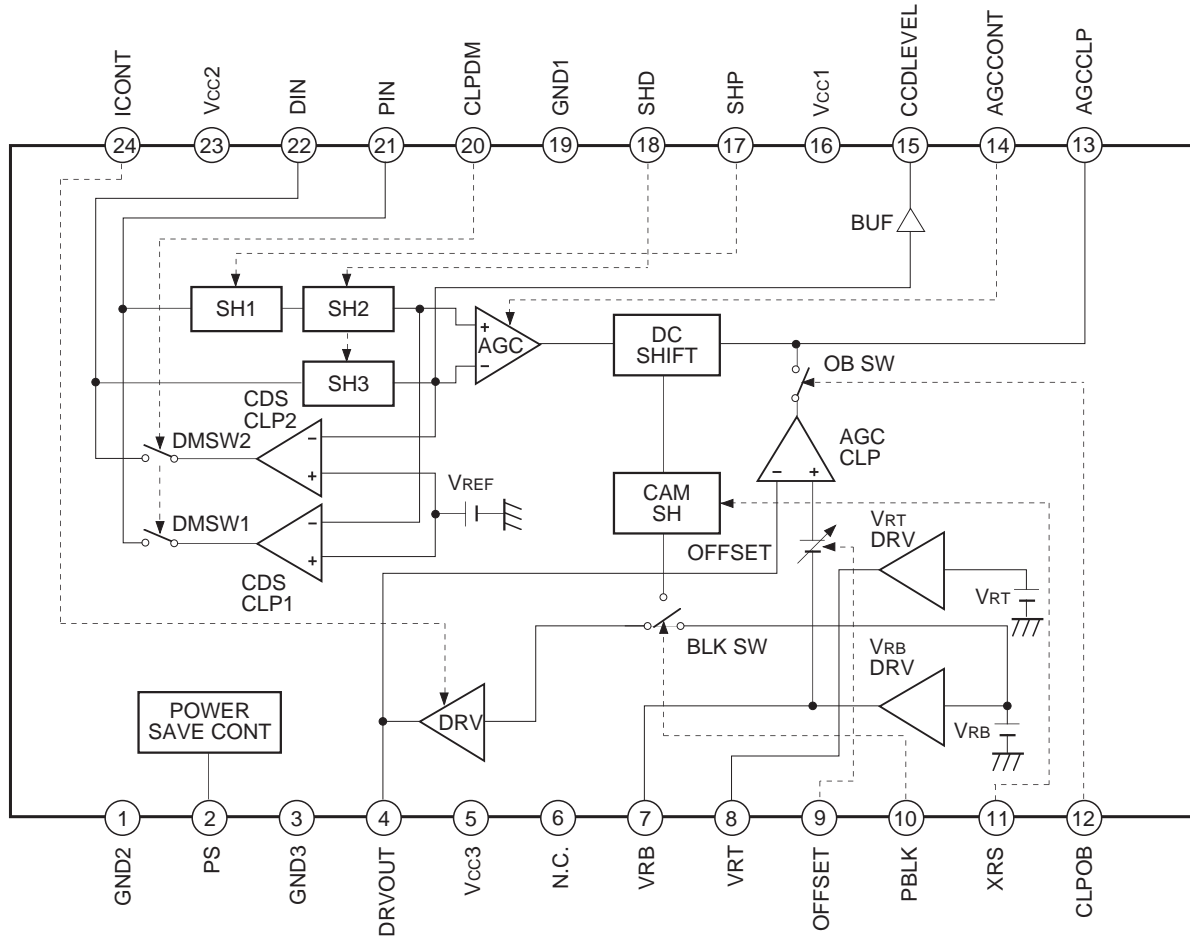



Pin Description

(Vcc1, 2, 3 = 3V)

| Pin No. | Symbol | Pin voltage | Equivalent circuit | Description |
|---------------|----------------------|---|--------------------|---|
| 1 3 19 | GND2 GND3 GND1 | GND | | Ground. |
| 2 | PS | VTH = 1.5V | | Power saving mode. |
| 4 | DRVOUT | V _{RB} to V _{RB} + 100mV | | Driver output for A/D converter capable of DC coupling. Dynamic range = 1Vp-p. |
| 5 16 23 | Vcc3 Vcc1 Vcc2 | Vcc | | Power supply. |

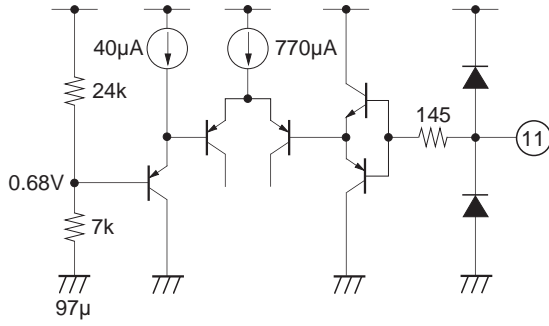
| Pin No. | Symbol | Pin voltage | Equivalent circuit | Description |
|---------|--------|---|--------------------|---|
| 6 | N.C. | | | No connection; normally ground. |
| 7 | VRB | 1.35V | | <p>1.35V regulator output.</p> <p>Be sure to decouple this pin near the IC pins to prevent the oscillation and external noise when this pin is not used. (Recommended capacitor value: 4.7µF)</p> |
| 8 | VRT | 2.35V | | <p>2.35V regulator output.</p> <p>Be sure to decouple this pin near the IC pins to prevent the oscillation and external noise when this pin is not used. (Recommended capacitor value: 4.7µF)</p> |
| 9 | OFFSET | 1.5 to 3V & 0V | | <p>Controls the output offset.</p> <p>When 3V: V_{RB} When 1.5V: $V_{RB} + 100mV$ When 0V (preset mode): $V_{RB} + 35mV$</p> |
| 10 | PBLK | <p>$V_{TH} = 1.85V$</p> <p>Active: Low</p> | | <p>Camera signal preblanking pulse input.</p> <p>Active when Low. Calibrates the black level of the AGC output waveform. When PBLK is Low, the DRVOUT potential is forced to V_{RB}.</p> |

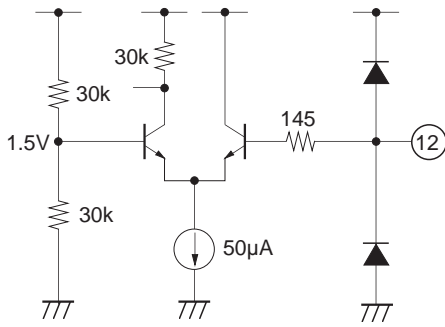
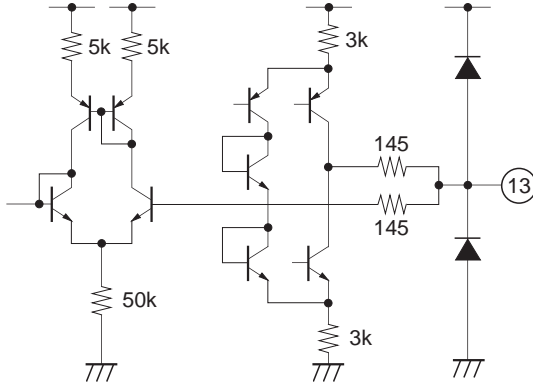
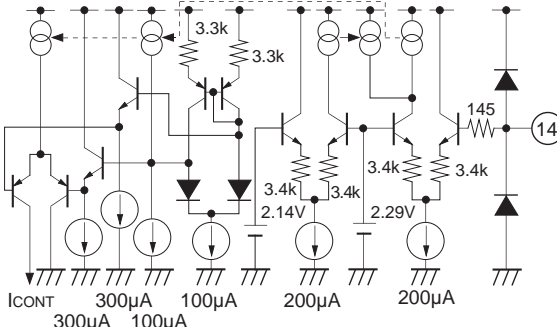
| Pin No. | Symbol | Pin voltage | Equivalent circuit | Description |
|---------|---------|--|--|---|
| 11 | XRS | <p>VTH = 0.68V</p>  |  | Camera signal sample-and-hold pulse input. |
| 12 | CLPOB | <p>VTH = 1.5V</p>  |  | Clamp pulse used to clamp the optical black portion of the camera signal after it passes through the AGC amplifier. |
| 13 | AGCCLP | Approx. 1.3V |  | AGC clamp capacitor. (Recommended value: 0.1µF) |
| 14 | AGCCONT | 1.5 to 3.0V |  | <p>AGC gain control.</p> <p>When 1.5V: -1dB (Minimum gain)</p> <p>When 3.0V: 31.5dB (Maximum gain)</p> |

Electrical Characteristics

(Ta = 25°C, Vcc1, 2, 3 = 3V)

| Item | Symbol | Conditions | Min. | Typ. | Max. | Unit | |
|---------------------|---------------------------------------|-----------------|---|------|------|------|----|
| Current consumption | PS = OFF (PS indicates Power Save) | I _{DC} | AGCCONT = 1.5V, open between V _{RT} and V _{RB} PS = 3V, I _{CONT} = 3V | 25.1 | 37.1 | 49.0 | mA |
| | PS = ON | I _{DP} | PS = 0V | 0 | 1.8 | 4.2 | |
| AGC | Maximum gain | A CONT max. | DIN = 1μs, 20mVp-p pulse AGCCONT = 3V, I _{CONT} = 3V | 28.5 | 31.3 | — | dB |
| | Minimum gain | A CONT min. | DIN = 1μs, 500mVp-p pulse AGCCONT = 1.5V, I _{CONT} = 3V | — | -0.8 | 1.4 | |
| | Range of gain variance | AGC G | A CON max. - A CON min. | 27.1 | 32.1 | — | |
| | Dynamic range maximum | AGCmax. D | AGCCONT = 3V DRVOUT output signal at saturation level | 800 | 970 | — | mV |
| | Dynamic range typical | AGCTYP. D | AGCCONT = 2V DRVOUT output signal at saturation level | 900 | 960 | — | |
| DRV | Offset high | CAOF high | OFFSET = 1.5V | 80 | 98 | — | mV |
| | Offset low | CAOF low | OFFSET = 3.0V | — | 2 | 5 | |
| | Offset preset | CAOF pre | OFFSET = 0V | 25 | 34 | 40 | |
| REF | V _{RT} DC level | VRTO | With a 400Ω load | 2300 | 2340 | 2400 | mV |
| | V _{RB} DC level | VRBO | With a 400Ω load | 1300 | 1353 | 1400 | |
| | V _{RT} - V _{RG} | ΔVR | With a 400Ω load | 950 | 988 | 1050 | |
| BLK | Offset | BLKOF | BLKOF (PBLK = 3V) - BLKOF (PBLK = 0V) | -15 | 9 | 30 | mV |
| SH3 | Dynamic range | SH3 D | DIN = 1μs, 1Vp-p pulse | 600 | 790 | — | mV |

Electrical Characteristics Measurement Circuit

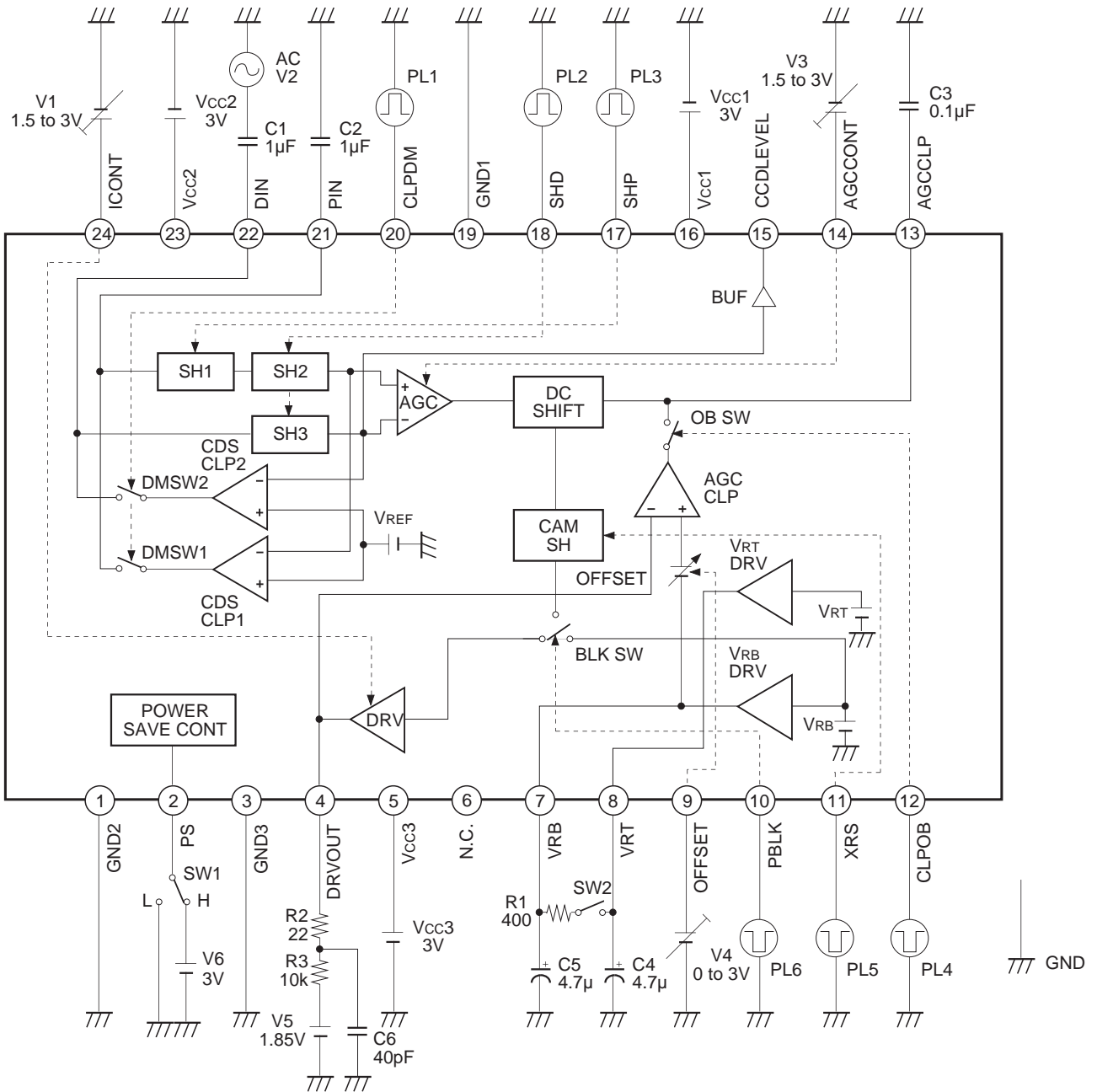

| SW1 | POWER SAVE |
|-----|------------|
| H | OFF |
| L | ON |

Measurement Timing Chart

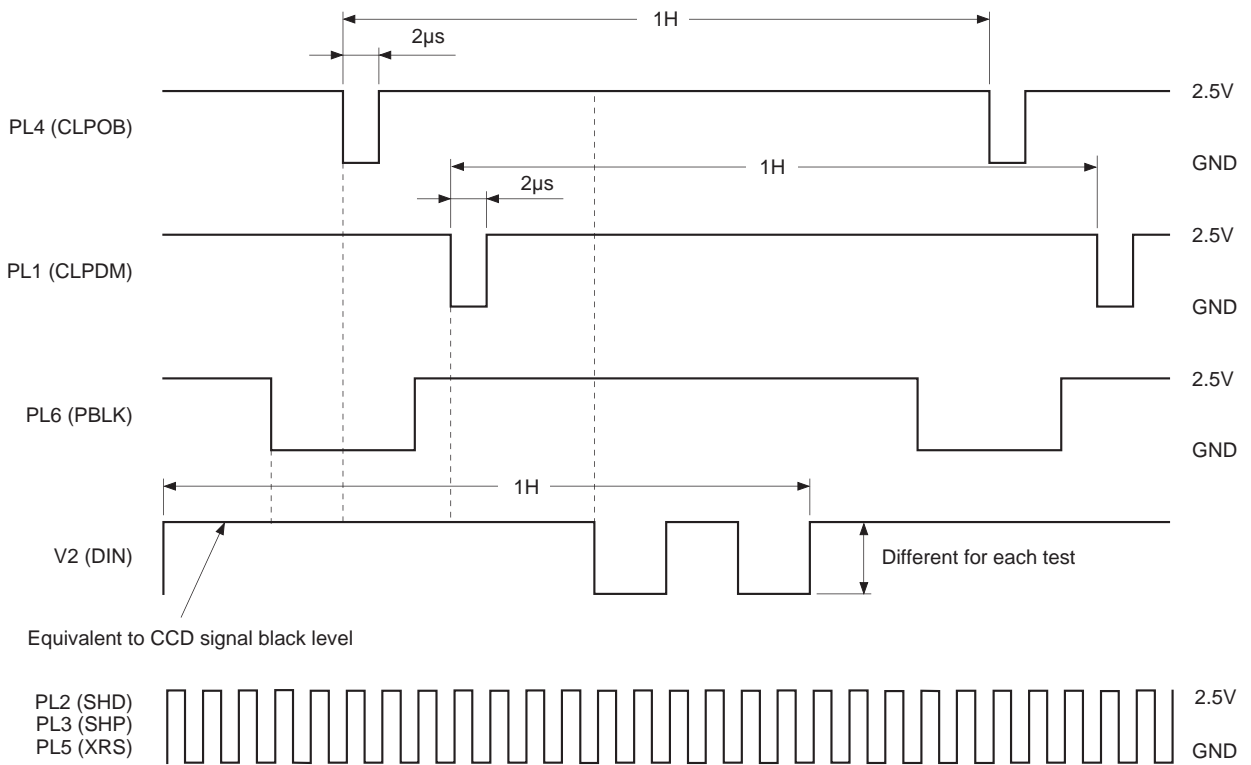

Application Circuit

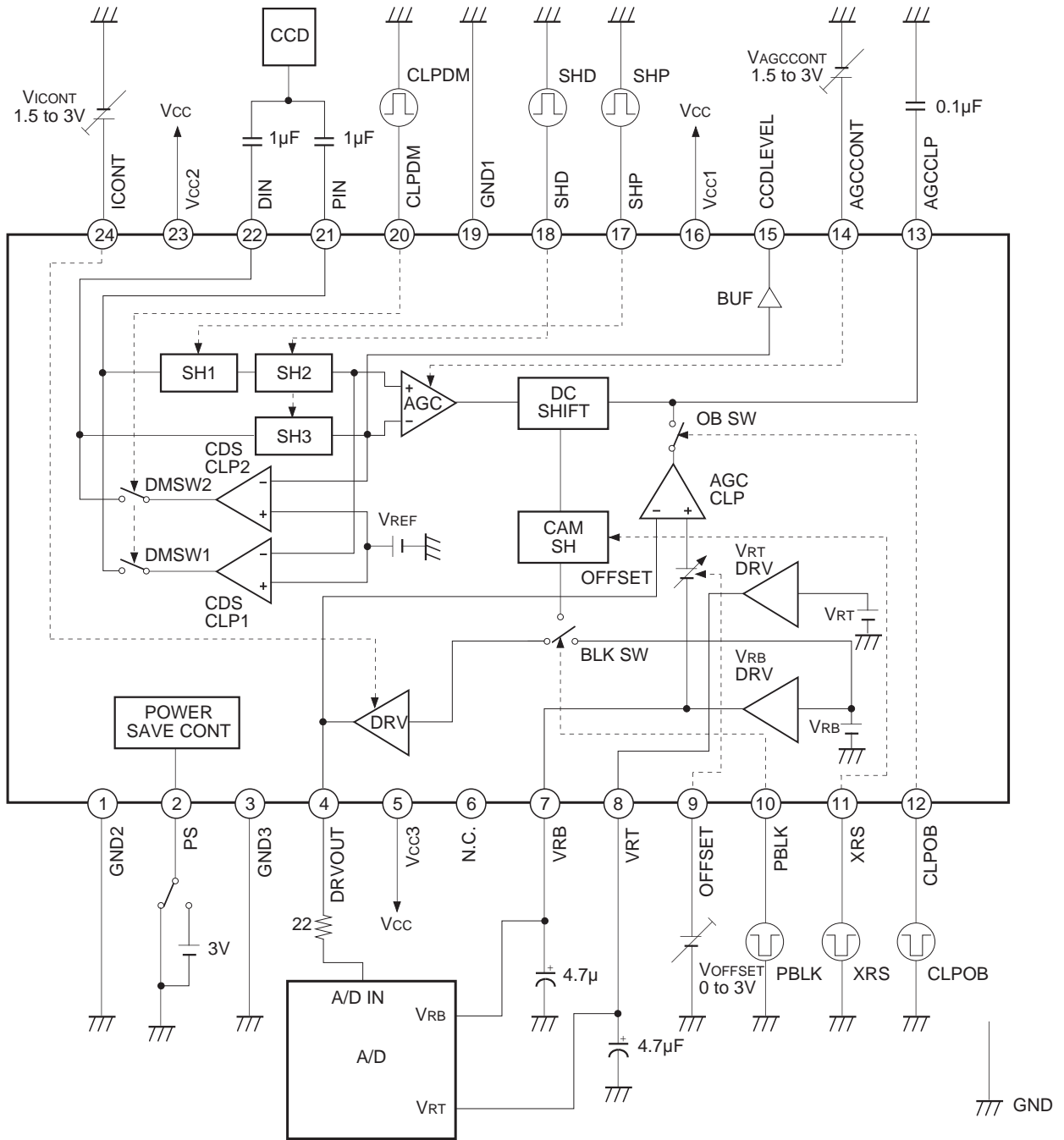

Application circuits shown are typical examples illustrating the operation of the devices. Sony cannot assume responsibility for any problems arising out of the use of these circuits or for any infringement of third party patent and other right due to same.

Description of Operation

Refer to the Block Diagram.

Operating Conditions

The camera signal processing system operates when PS is High.

Timing Chart (when $V_{CC} = 3V$)

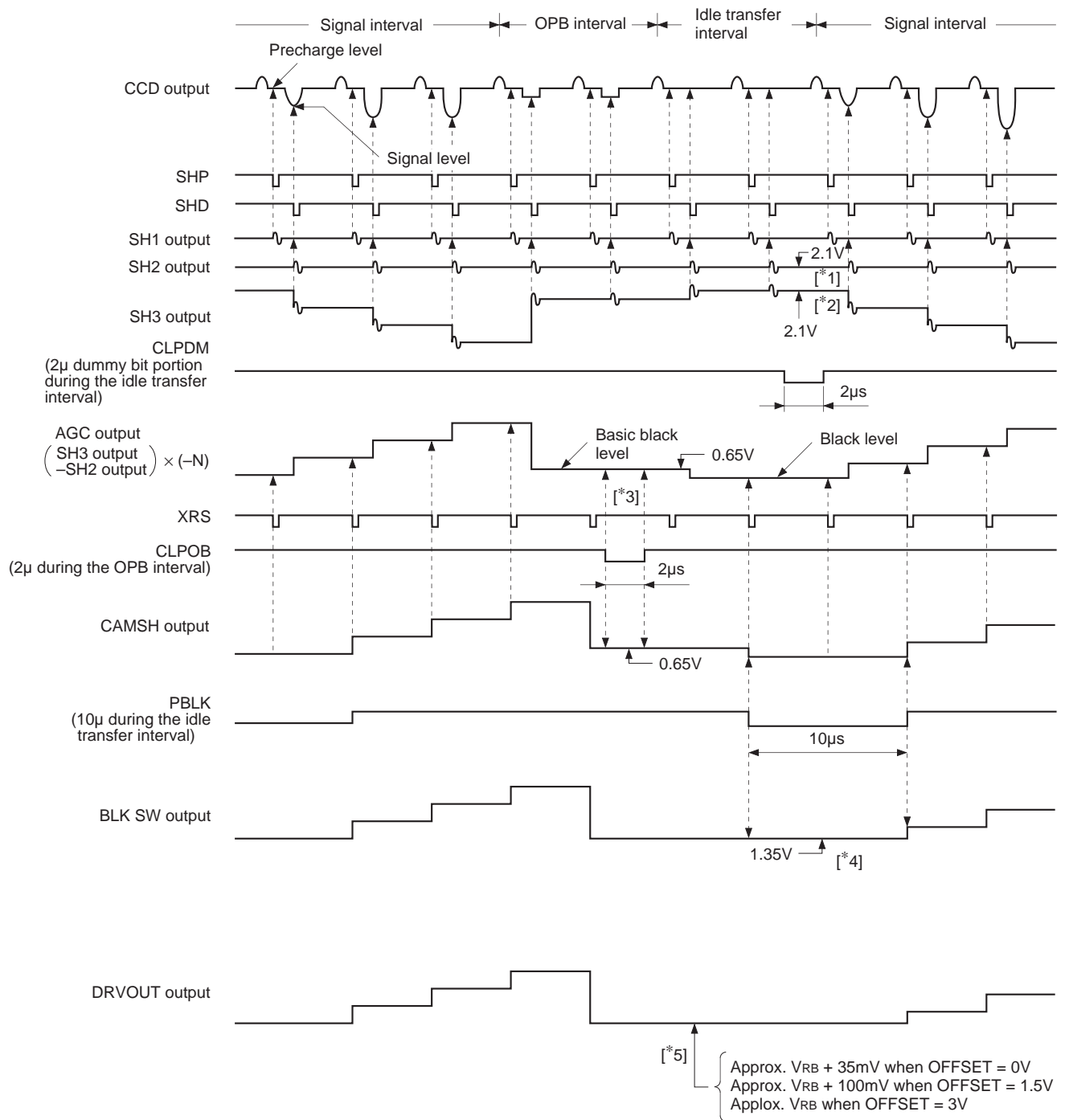

CDS (SH1, SH2, SH3):

The CCD signal from the CCD image sensor is input to PIN and DIN where correlated double sampling (CDS) is performed by SH1, SH2 and SH3. The precharge level of the CCD output signal is sampled, held and output by the SH2 output, and the signal level is sampled, held and output by the SH3 output. SH1 and SH2 are the sample-and-hold circuits for the precharge level; SH3 is the sample-and-hold circuit for the signal level.

CDSCLP 1, 2:

CDSCLP1 and 2 stabilize the input signal DC level, clamp (CLPDM) the input signal during the idle transfer interval for the purpose of eliminating the AGC input offset, and adjust the DC level ([*1], [*2]) of SH2 and SH3 in line with V_{REF} . CDSCLP1 is the clamp circuit for the precharge level, and CDSCLP2 is the clamp circuit for the signal level.

AGC:

AGC is the gain control amplifier for the camera signal.

The gain can be varied from -1 to $+31$ dB by adjusting the AGCCONT voltage control $V_{AGCCONT}$ from 1.5 to 3.0V.

CAM SH:

CAM SH is the sample-and-hold circuit for synchronizing the data read-in timing for the external A/D. Sampling is possible according to the approximately 10ns sampling pulse width input to XRS.

AGCCLP:

The basic black level is set ([*3]) by clamping the AGC output waveform with the CLPOB clock during the OPB interval. When PBLK is High and CLPOB is Low, the clamping circuit operates, adjusting the AGCCLP current so that the DRVOUT potential equals the OFFSET potential (which is determined by the voltage applied to the OFFSET pin), thus setting the AGCCLP potential. The AGCCLP capacitance is connected to the AGCCLP pin.

DC SHIFT:

This circuit functions when AGCCLP operates, following the AGCCLP potential and forcing a DC shift of the AGC output waveform OPB interval to the basic black level. When AGCCLP is not operating, the basic black level is maintained at its previous setting.

BLK SW:

The black level is calibrated by blanking the black level signal of the AGC output waveform so that it does not fall below the basic black level and replacing the DC potential with V_{RB} . ([*4])

The signal is blanked when PBLK is Low.

OFFSET:

OFFSET controls the DRV output waveform black level offset.

The offset of the DRVOUT camera signals can be adjusted when a voltage is applied to OFFSET. ([*5])

The voltage controlled by OFFSET is output as the DRV output DC offset via AGCCLP, DCSHIFT, CAMSH and BLKSW.

When the OFFSET voltage is 1.5 to 3.0V, DRVOUT DC can vary in a linear fashion from $V_{RB} + 100$ mV to V_{RB} .

In addition, when the OFFSET voltage is 0V, DRVOUT DC is preset to $V_{RB} + 35$ mV.

DRV:

DRV drives the external A/D. The current that flows to the last-stage amplifier in DRV is controlled by applying voltage to the ICONT pin, making it possible to adjust the rise time of the output waveform, which affects the external A/D load capacitance. The variable range is 1.5 to 3V, with 1.5V yielding the maximum and 3V yielding the minimum. The optimum rise time for the external A/D input capacitance can be selected.

V_{RT}DRV, V_{RB}DRV:

These are the external A/D reference voltage drivers. These circuits are connected to A/D V_{RT} and V_{RB}, supplying 2.35V and 1.35V, respectively, when V_{CC} is 3V. The IC's internal primary voltage is also generated on the basis of the V_{RT} and V_{RB} voltage. (V_{RB}, V_B and V_{CENT})

POWER SAVE CONTROL:

The PS pin is the power save pin; the operating state is enabled when this pin is High, while the power saving function operates when it is Low.

Characteristics Graphs

AGCCONT control supply voltage characteristics
VAGCCONT vs. Gain

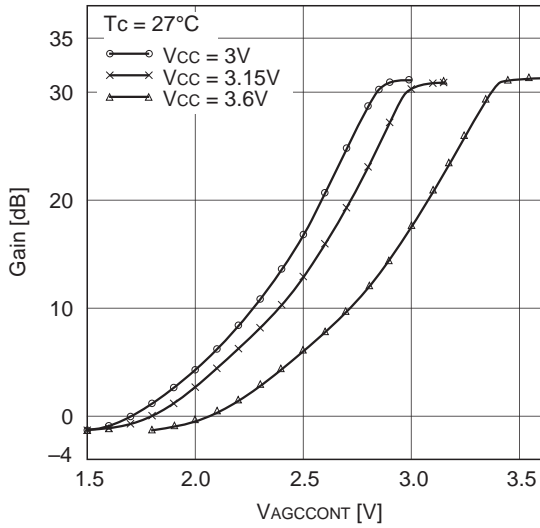

OFFSET control supply voltage characteristics
VOFFSET vs. OFFSET

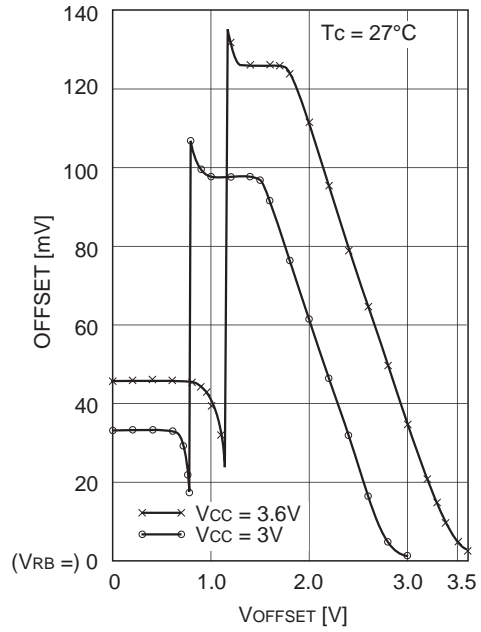

AGCCONT control temperature characteristics
AGCCONT vs. Gain

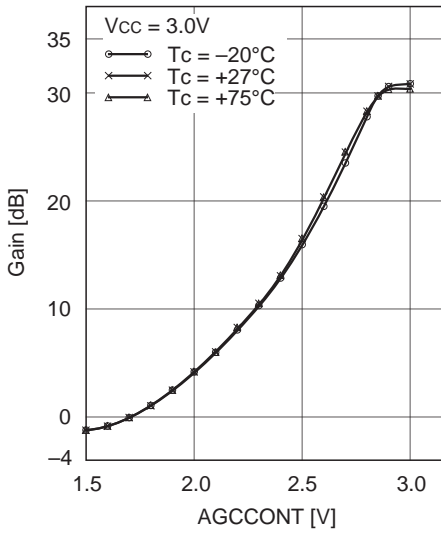

OFFSET control temperature characteristics
VOFFSET vs. OFFSET

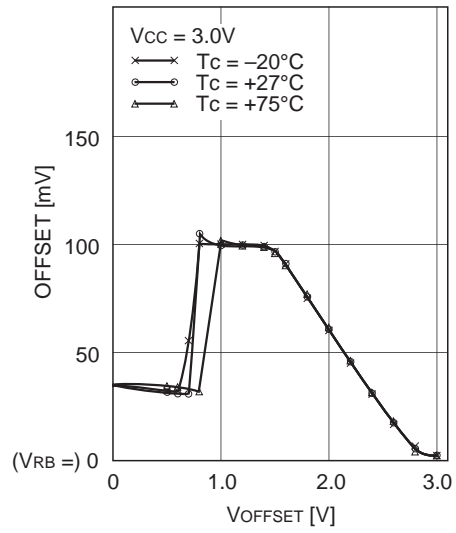

Maximum signal amplitude temperature characteristics (Max. gain) Tc vs. Vout

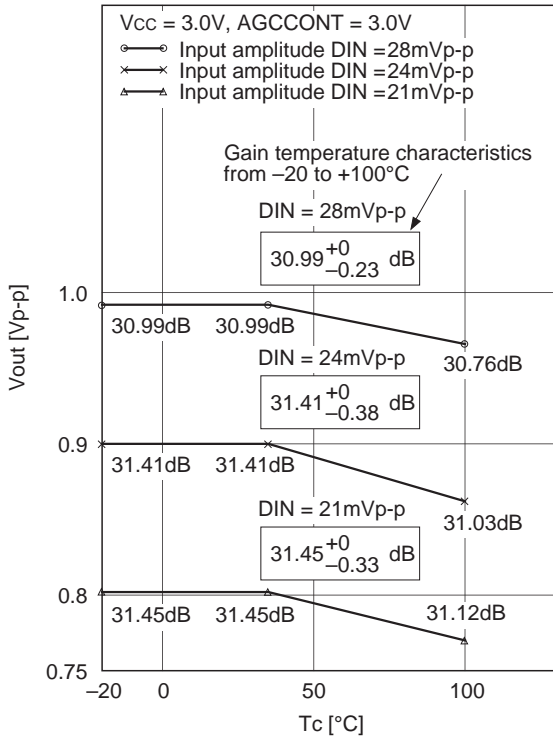

Maximum signal amplitude temperature characteristics (Min. gain) Tc vs. Vout

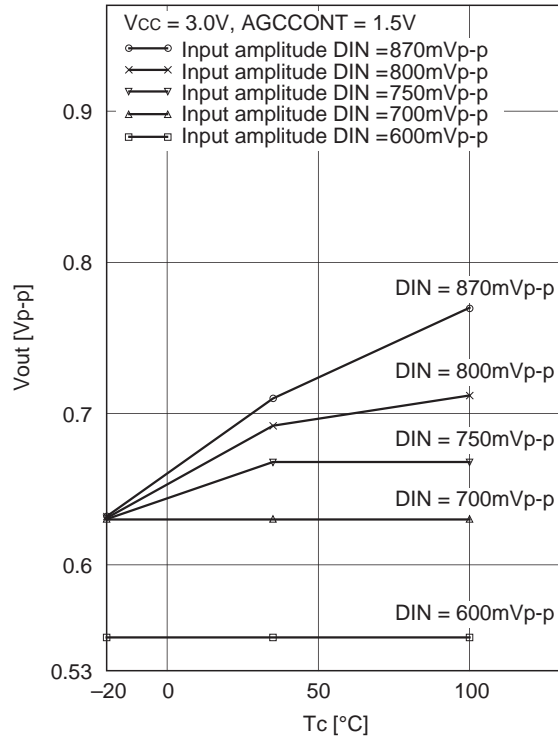

VRT, VRB, VRT - VRB temperature characteristics Tc vs. VRT, VRB, VRT - VRB

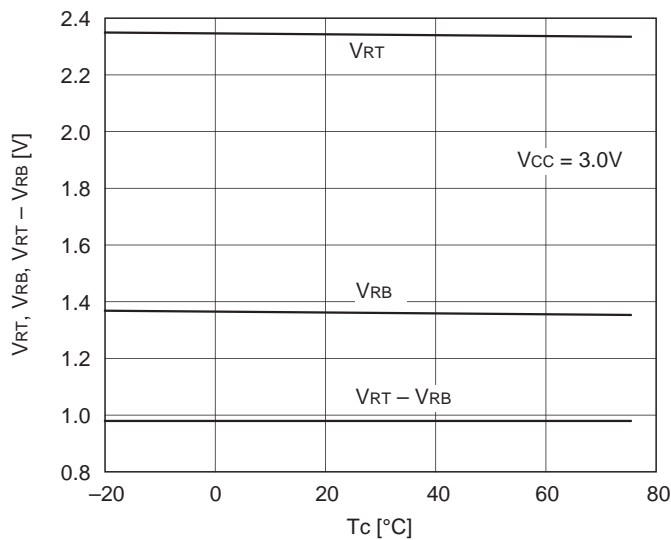

Package Outline Unit: mm

24PIN SSOP(PLASTIC)

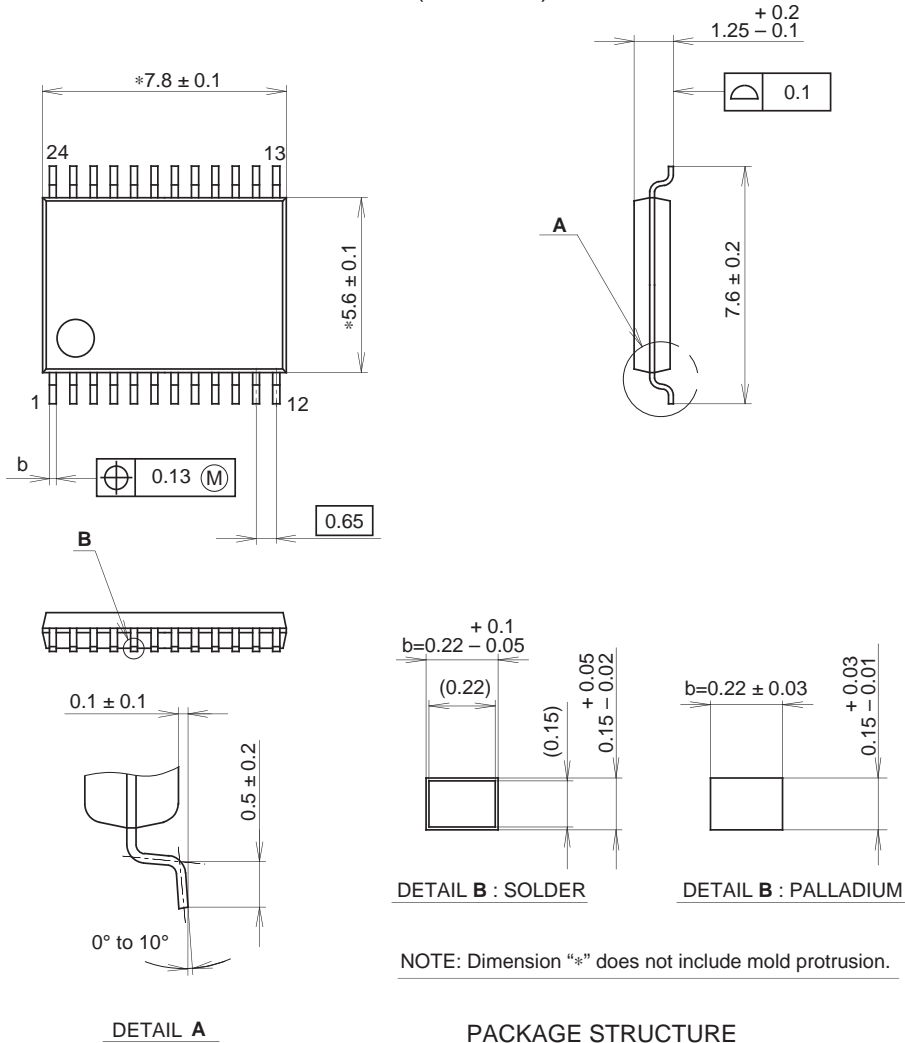

NOTE: Dimension "*" does not include mold protrusion.

| | |
|------------|----------------|
| SONY CODE | SSOP-24P-L01 |
| EIAJ CODE | SSOP024-P-0056 |
| JEDEC CODE | _____ |

PACKAGE STRUCTURE

| | |
|------------------|--------------------------|
| PACKAGE MATERIAL | EPOXY RESIN |
| LEAD TREATMENT | SOLDER/PALLADIUM PLATING |
| LEAD MATERIAL | 42/COPPER ALLOY |
| PACKAGE MASS | 0.1g |

NOTE : PALLADIUM PLATING
 This product uses S-PdPPF (Sony Spec.-Palladium Pre-Plated Lead Frame).

This datasheet has been downloaded from:

www.DatasheetCatalog.com

Datasheets for electronic components.



LittleDiode supplies new, hard to find or obsolete electronic components and semiconductors all over the world.

With over two million different components listed you are sure to find the part you need.

Feel free to visit us today at our online store:

LittleDiode.com

Looking forward to providing you with the best possible service.