

2-channel REC/PB Amplifier for 8 mm VTR

Description

The CXA2032Q is a bipolar IC designed as recording/playback amplifiers for 8 mm VTRs.

Features

- Recording system
- Supports EVR control for recording Y/low-band recording level
 - Feedback damping circuit provided in the recording amplifier
- Playback system
- Feedback damping circuit provided in the playback amplifier facilitates printed circuit board design
 - RFAGC and dropout detection circuit

Applications

8 mm VTR

Structure

Bipolar silicon monolithic IC

32 pin QFP (Plastic)

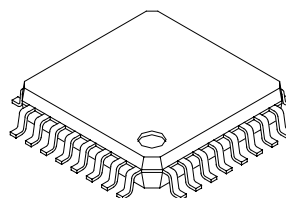

Absolute Maximum Ratings (Ta=25 °C)

• Supply voltage	V _{CC}	7	V
• Operating temperature	T _{opr}	-10 to +75	°C
• Storage temperature	T _{stg}	-65 to +150	°C
• Allowable power dissipation	P _D	450	mW

Operating Condition

Supply voltage	V _{CC}	4.5 to 5.25	V
----------------	-----------------	-------------	---

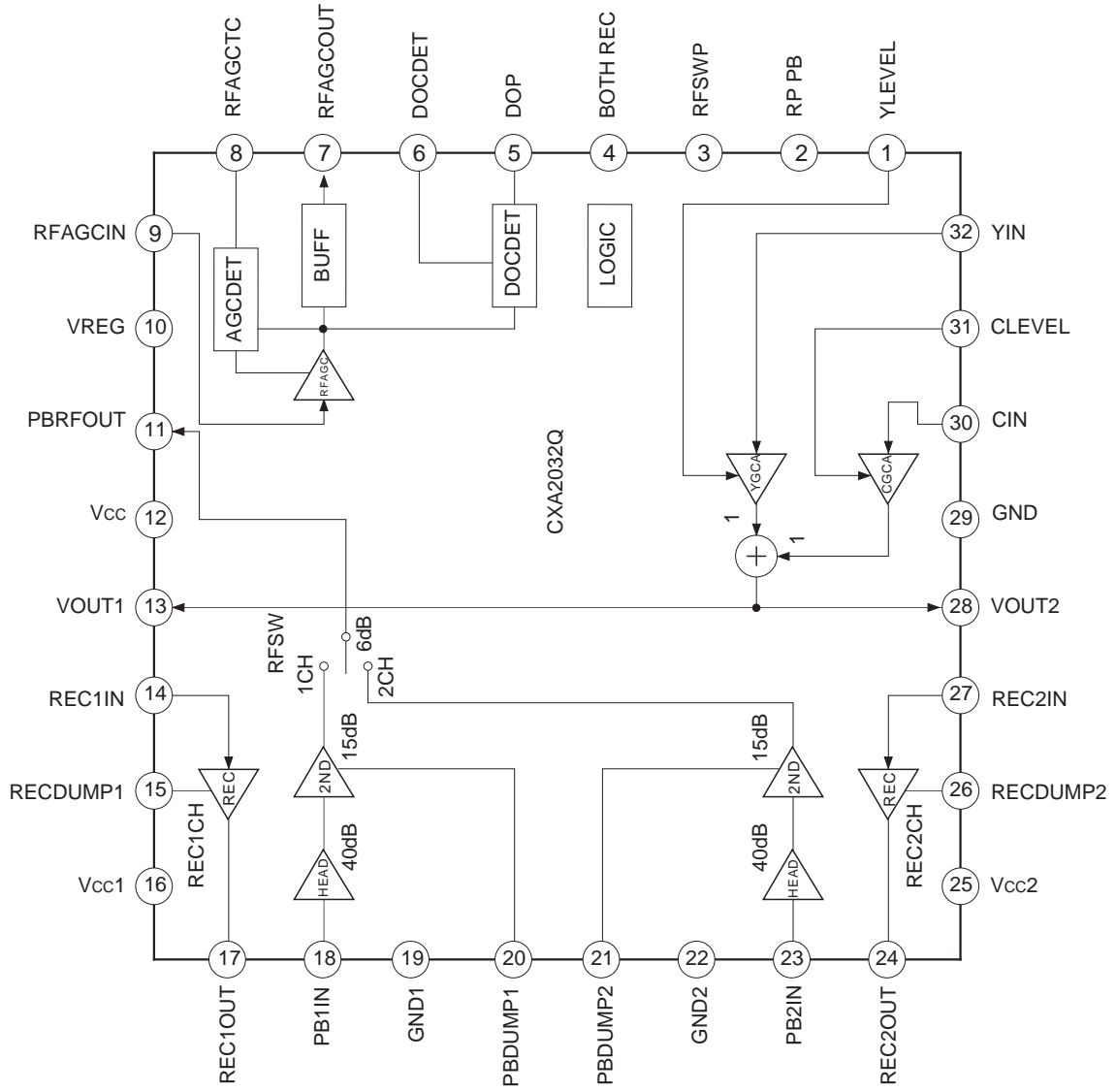

Block Diagram and Pin Configuration

Pin Description

(Vcc, Vcc1ch, Vcc2ch=4.75 V Ta=25 °C)

Pin No.	Symbol	Pin voltage		Equivalent circuit	Description
		DC	AC		
1	YLEVEL	0 V to 4.75 V input	—		<p>EVR adjusting pin for Y signal level during recording. The control voltage is from 0 V to 4.75 V.</p> <p>Increasing the input voltage increases the Y signal level.</p>
2	RP PB	H: 2.3 V or more L: 0.6 V or less input	—		<p>Input pin for REC/PB mode switching signal.</p> <p>H: PB L: REC</p>
3	RFSWP	H: 2.3 V or more L: 0.6 V or less input	—		<p>Input pin for RFSWP signal.</p>
4	BOTH REC	H: 2.3 V or more L: 0.6 V or less input	—		<p>Alternate recording/both channel recording switching pin.</p> <p>H: Both channel recording L: Alternate recording</p>

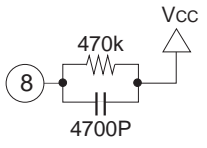
Pin No.	Symbol	Pin voltage		Equivalent circuit	Description
		DC	AC		
5	DOP	H: 3.15 V L: 0.0 V output	—		Output pin for dropout detection signal. Goes High during dropout.
6	DOCDET	2.6 V (when pin is open)	—		Pin for deciding dropout detection level. Connect decoupling capacitance between this pin and GND. For adjustment, input voltage proportional to Pin 10 (VREG) output voltage. Increasing the input voltage increases the detection level.
7	RFAGCOUT	2.8 V	400mVp-p output		Output pin for playback Y signal.
8	RFAGCTC	2.5 V to 4.75 V input (during EVR adjustment)	—		RFAGC time constant pin.  RFAGC gain can be adjusted by EVR. Increasing the input voltage increases the gain.

Pin No.	Symbol	Pin voltage		Equivalent circuit	Description
		DC	AC		
9	RFAGCIN	—	220mVp-p input		Input pin for playback Y signal. Playback Y signal is separated from playback video signal output to Pin 11 (PBRFOUT), then input to Pin 9 (RFAGCIN).
10	VREG	4.15 V	—		Output pin for 4.15 V regulator. Connect decoupling capacitance between this pin and GND.
11	PBRFOUT	2.0 V	220mVp-p (playback Y signal output)		Output pin for playback video signal.
12	Vcc	4.75 V	—		Power supply pin for main blocks excluding recording and head amplifiers.

Pin No.	Symbol	Pin voltage		Equivalent circuit	Description
		DC	AC		
13	VOUT1	3.4 V	184mVp-p (recording Y signal output)		<p>Recording video signal 1ch output pin.</p> <p>The signal obtained by mixing the recording Y, recording C, recording AFM and recording ATF signals is output.</p>
14	REC1IN	0.7 V	120 µAp-p input		<p>Recording video signal 1ch REC AMP input pin.</p> <p>Pin 13 (VOUT1) output is V/I converted by external resistor, then input to Pin 14 (REC1IN).</p>
15	RECDUMP1	1.4 V	—		<p>Damping adjusting pin for 1ch recording amplifier.</p> <p>Damping is adjusted by attaching damping resistor between Pin 15 and GND.</p> <p>Decreasing the resistance value increases the damping.</p>
16	Vcc1	4.75 V	—		<p>Power supply pin for 1ch recording and head amplifiers.</p>

Pin No.	Symbol	Pin voltage		Equivalent circuit	Description
		DC	AC		
17	REC1OUT	16.5 mA output	19 mAp-p output		Recording signal 1ch output pin. This pin is an open collector.
18	PB1IN	0.7 V	200 µVp-p input		Playback signal 1ch input pin.
19	GND1	0 V	—		GND pin for 1ch recording and head amplifiers.
20	PBDUMP1	2.6 V	—		Damping adjusting pin for 1ch head amplifier.

Pin No.	Symbol	Pin voltage		Equivalent circuit	Description
		DC	AC		
21	PBDUMP2	2.6 V	—		Damping adjusting pin for 2ch head amplifier.
22	GND2	0 V	—		GND pin for 2ch recording and head amplifiers.
23	PB2IN	0.7 V	200 μ Vp-p input		Playback signal 2ch input pin.
24	REC2OUT	16.5 mA output	19 mA p-p output		Recording signal 2ch output pin. This pin is an open collector.

Pin No.	Symbol	Pin voltage		Equivalent circuit	Description
		DC	AC		
25	Vcc2	4.75 V	—		Power supply pin for 2ch recording and head amplifiers.
26	RECDUMP2	1.4 V	—		Damping adjusting pin for 2ch recording amplifier. Damping is adjusted by attaching damping resistor between Pin 26 and GND. Decreasing the resistance value increases the damping.
27	REC2IN	0.7 V	120 μ Ap-p input		Recording video signal 2ch REC AMP input pin. Pin 28 (VOUT2) output is V/I converted by external resistor, then input to Pin 27 (REC2IN).
28	VOUT2	3.4 V	184mVp-p (recording Y signal output)		Recording video signal 2ch output pin. The signal obtained by mixing the recording Y, recording C, recording AFM and recording ATF signals is output.

Pin No.	Symbol	Pin voltage		Equivalent circuit	Description
		DC	AC		
29	GND	0 V	—		GND pin for main blocks excluding recording and head amplifiers.
30	CIN	3.45 V	136mVp-p (recording C signal input)		Input pin for recording C, recording AFM and recording ATF signals. These three signals are mixed by external resistor, then input to Pin 30 (CIN).
31	CLEVEL	0.0 V to 4.75 V input	—		EVR adjusting pin for low-band recording signal (C, AFM, ATF) level. The control voltage is from 0 V to 4.75 V. Increasing the input voltage increases the low-band recording signal level.
32	YIN	3.05 V	500mVp-p		Input pin for recording Y signal.

*See the Control Logic Truth Table for control logic.
 (V_{CC}=4.75 V, T_a=25 °C, See the Electrical Characteristics Measurement Circuit.)

Electrical Characteristics Target Values

No.	Item	Symbol	Measurement conditions				Measurement		Measurement method	Min.	Typ.	Max.	Unit
			Input conditions		Log ic	pin or ammeter name							
			Pin	Level			Frequency						
1	Circuit current during recording	I _{rec}	—	—	B	IV _{CC}	Current consumption inside IC during switching recording *1	20	29	38	mA		
2	Circuit current during playback	I _{pb}	—	—	F	IV _{CC}	Current consumption inside IC during playback	16	23	30	mA		
3	VREG pin voltage	V _{REG}	—	—	B	10	Pin voltage measurement	3.95	4.15	4.35	V		
Recording system (*1: Including recording amplifier 1ch output bias current)													
4	Recording Y signal GCA minimum gain	G _{YMIN}	32	1120 mVp-p	300 kHz	B	13	Pin 1 (YLEVEL) = 0 V	—	-17.2	-15.7	dB	
5	Recording Y signal GCA maximum gain	G _{YMAX}	32	225 mVp-p	300 kHz	B	13	Pin 1 (YLEVEL) = 4.75 V	-1.7	0.9	—	dB	
6	Recording Y signal GCA frequency response (center)	V _{FY}	32	500 mVp-p	10 MHz	B	13	10 MHz level/300 kHz level Pin 1 (YLEVEL) = V _{ylev} (center gain)	-1.3	-0.3	0.7	dB	
7	Recording Y signal GCA secondary distortion (center gain)	D _Y	32	500 mVp-p	7 MHz	B	13	Pin 1 (YLEVEL) = V _{ylev} (center gain)	—	-50	—	dB	
8	Recording C signal GCA minimum gain	G _{CMIN}	30	305 mVp-p	300 kHz	B	13	Pin 31 (CLEVEL) = 0 V	—	-17.8	-16.4	dB	
9	Recording C signal GCA maximum gain	G _{CMAX}	30	60 mVp-p	300 kHz	B	13	Pin 31 (CLEVEL) = 4.75 V	-2.4	0.6	—	dB	
10	Recording C signal GCA frequency response (center)	V _{FC}	30	136 mVp-p	2 MHz	B	13	2 MHz level/300 kHz level Pin 31 (CLEVEL) = C _{ylev} (center gain)	-0.5	0	0.5	dB	
11	Recording C signal GCA secondary distortion (maximum gain)	DC	30	90 mVp-p	700 kHz	B	13	Pin 31 (CLEVEL) = 4.75 V	—	-56	—	dB	

No.	Item	Symbol	Measurement conditions				Measurement pin or ammeter name	Measurement method	Min.	Typ.	Max.	Unit									
			Pin	Input conditions Level	Frequency	Log ic															
12	Recording AFM signal secondary distortion (maximum gain)	D AFM	30	90 mVp-p	1.7 MHz	B	13	Pin 31 (CLEVEL) = 4.75 V	-55	—	—	dB									
13	Recording amplifier output bias current	IB1, 2	—	—	—	B	IB1, 2	DC current measurement	16.5	20.2	20.2	mA									
14	Recording amplifier output current	IR1	14	184 mVp-p	1 MHz	B	17	Output level (mVp-p)/51 Ω	19	21.4	21.4	mA p-p									
		IR2	27	184 mVp-p	1 MHz	B	24	Output level (mVp-p)/51 Ω													
15	Recording amplifier frequency response	ΔR1	14	184 mVp-p	10 MHz	B	17	10 MHz level/1 MHz level	0	—	—	dB									
		ΔR2	27	184 mVp-p	10 MHz	B	24	10 MHz level/1 MHz level													
Playback system																					
16	Playback amplifier, RFSW gain	GV1	18	200 μVp-p	300 kHz	F	11		57.9	61.4	64.9	dB									
		GV2	23	200 μVp-p	300 kHz	E	11														
17	RFAGC standard output	V AGC1	9	224 mVp-p	7 MHz	F	7	Measure output level, applying time constant to Pin 8 (RFAGCTC).	330	400	470	mV p-p									
18	RFAGC cover range High	V AGC2	9	56 mVp-p	7 MHz	F	7		310	375	—										
19	RFAGC cover range Low	V AGC3	9	896 mVp-p	7 MHz	F	7		—	425	495										
20	Dropout detection ON level	K DO-ON	See Measurement method (figure to right).				5	Apply time constant to Pin 8 (RFAGCTC).	Apply time constant to Pin 8 (RFAGCTC).	-13.5	-10.5	-7.5	dB								
21	Dropout detection OFF level	K DO-OFF					5							5	-8.5	-5.5	-2.5				
22	Dropout pulse Low level	V DOP-L					5							5	5	5	0	0.01	0.2	0.2	V
		V DOP-H					5							5	5	5	2.9	3.15	3.4	3.4	

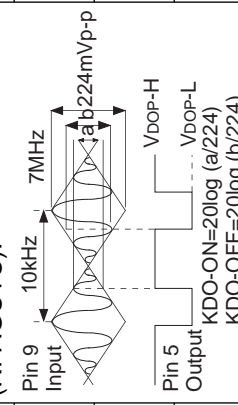

No.	Item	Symbol	Measurement conditions				Measurement pin or ammeter name	Measurement method	Min.	Typ.	Max.	Unit
			Input conditions		Log ic							
			Pin	Level		Frequency						
24	Dropout ON detection time	T DOP -ON			F	5	Apply time constant to Pin 8 (RFAGCTC). 	—	1	—	μs	
25	Dropout OFF detection time	T DOP -OFF	See Measurement method (figure to right).			5		—	2	—		

Control Logic Truth Table

Name of control logic conditions	Input conditions and operation			Control logic input conditions								Operation of each section under respective input conditions					Operation	Mode
	RPPB	RFSWP	BOTH REC	Recording system				Playback system				PB1 AMP	PB2 AMP	PBRFOUT	RFA G C OUT	DO C DET		
				VOUT1	VOUT2	REC1OUT	REC2OUT	PB1 AMP	PB2 AMP	PBRFOUT	RFA G C OUT							
2	3	4	13	28	17	24					11	7						
A	L	L	L	V	V	Δ	V	×	×	×	×	×	×	VIDEO EACH REC	REC			
B	L	H	L	V	V	V	Δ	×	×	×	×	×	↓					
C	L	L	H	V	V	V	V	×	×	×	×	×	VIDEO BOTH REC					
D	L	H	H	V	V	V	V	×	×	×	×	×	↓					
E	H	L	—	×	×	×	×	O	O	CH2	O	O	PB	PB				
F	H	H	—	×	×	×	×	O	O	CH1	O	O	↓					

(Description of input conditions)

- H . . . Control logic input voltage of 2.3 V or more
- L . . . Control logic input voltage of 0.6 V or less
- . . . Don't care.

(Description of operation mode)

- O . . . Operating
- ×
 . . . Not operating || V . . . Video signal is output. | Δ . . . Operating but bias current is OFF. |
| CH1 . . . CH1 signal is output. | CH2 . . . CH2 signal is output. |

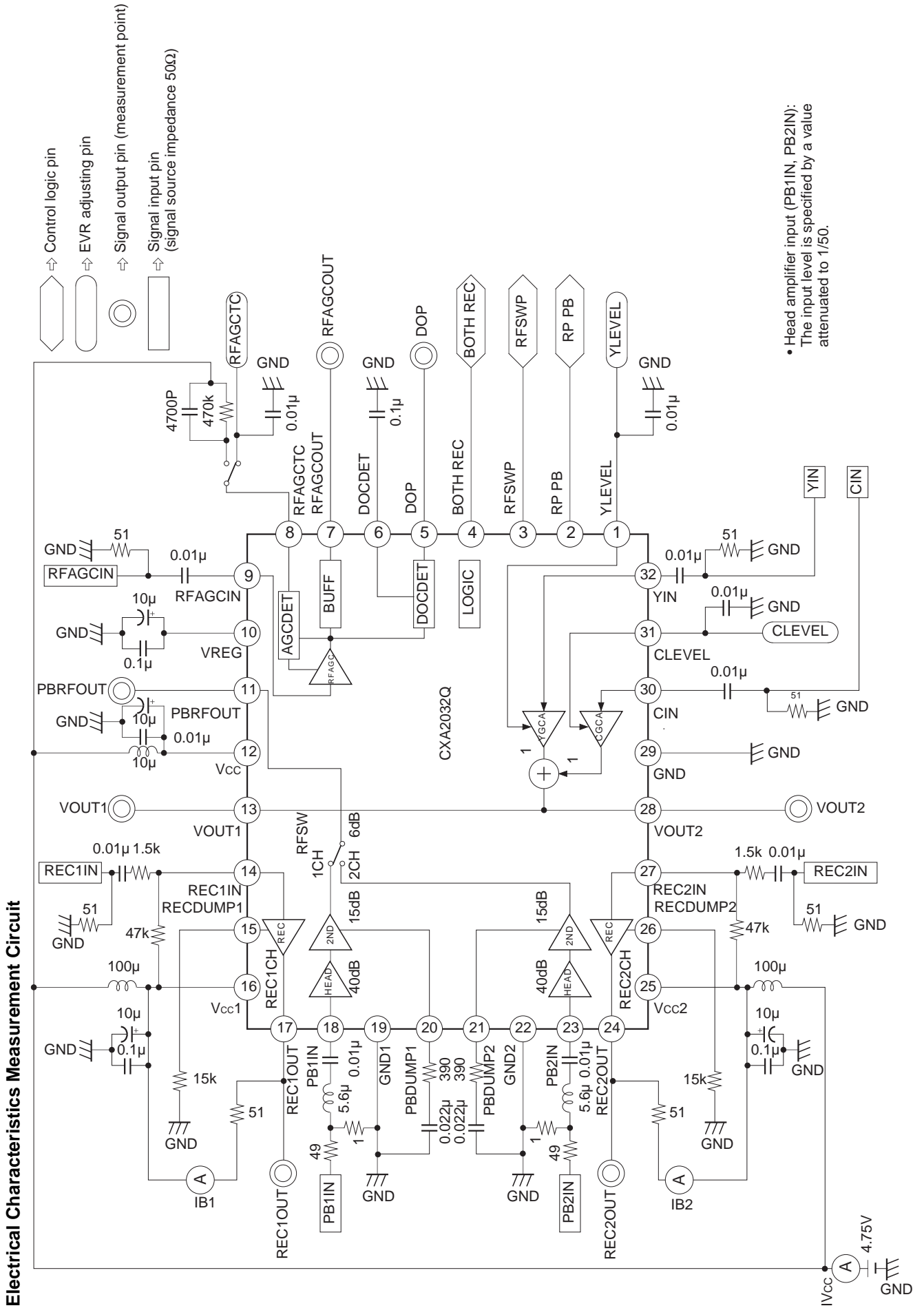

Application Circuit

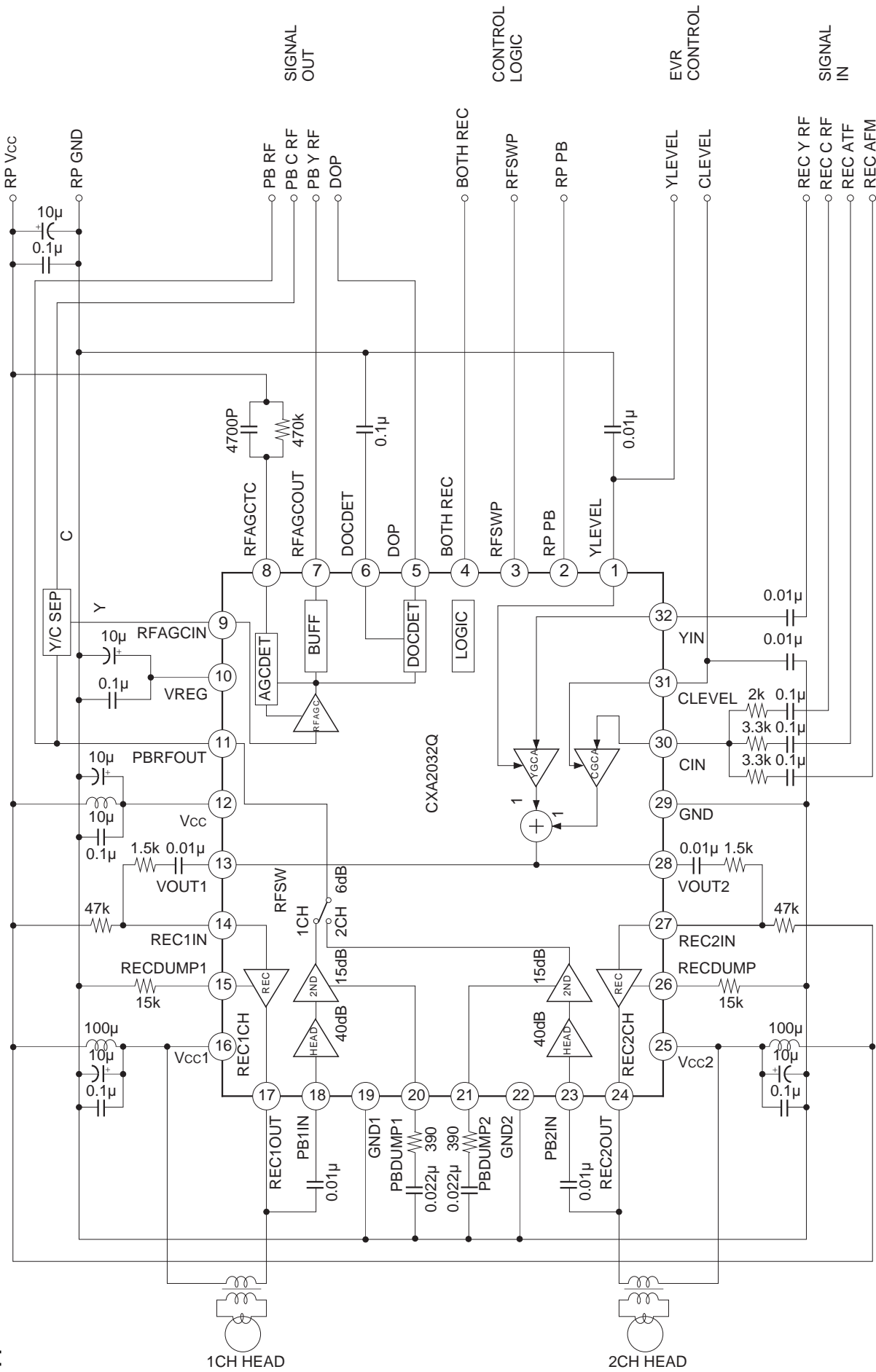

Application circuits shown are typical examples illustrating the operation of the devices. Sony cannot assume responsibility for any problems arising out of the use of these circuits or for any infringement of third party patent and other right due to same.

Description of Operation

<Recording level adjustment>

Y, chroma, AFM and ATF signals are adjusted at specified levels so that they are mixed internally to achieve an appropriate value at the head, then output to Pins 13 (VOUT1) and 28 (VOUT2). The Y level is EVR adjusted at Pin 1 (YLEVEL) and the low-band level (chroma, AFM, ATF) at Pin 31 (CLEVEL).

<Recording amplifier>

The signal, which underwent recording level adjustment, is V/I converted by external resistor, then input to Pins 14 (REC1IN) and 27 (REC2IN). The current of the input signal is amplified by the recording amplifier, and this signal is then output from Pins 17 (REC1OUT) and 24 (REC2OUT) to drive the head. A feedback damping circuit is incorporated into the recording amplifier to inhibit head resonance, and the peaking amount can be adjusted by external resistors attached to Pins 15 (RECDUMP1) and 26 (RECDUMP2). During recording, the output capacitance is about 12 pF including that of the playback amplifier.

<Playback amplifier>

The playback signal from the head is amplified with low noise and high gain. A feedback damping circuit is incorporated to inhibit head resonance, and the peaking amount can be adjusted by external resistors attached to Pins 20 (PBDUMP1) and 21 (PBDUMP2).

During playback, the output capacitance is approximately 20 pF including that of the recording amplifier.

<RFSW>

This section switches the playback signals of channels 1 and 2 at the correct timing and outputs the playback video signal to Pin 11 (PBRFOUT). Switching is performed at Pin 3 (RFSWP).

<RFAGC>

This section inputs the playback Y signal separated from playback video signal using an external circuit and outputs it at a constant level of 400 mVp-p.

<Dropout detection>

A dropout is detected in the playback Y signal, and a dropout pulse is output. The detection level is optimized using 224 mVp-p input as a reference.

<Control logic>

In order to save power consumption, this IC exercises power-saving control of circuit blocks which are not in need for operation depending on the mode. The IC also incorporates a logic circuit for controlling the built-in switches which change inputs and outputs.

The combinations of input and output required for basic operation are shown in the Control Logic Truth Table.

<Reference voltage in the IC>

VREG 4.15 V is generated as the reference voltage used in the IC.

Notes on Operation

1. This IC is characterized by high-voltage gain (approximately 61 dB in the playback system). Be careful of the following when using the IC.

- 1) Use a reinforced power supply and ground lines. Decouple the power supply pin with a coil and a capacitor. Connect each decoupling capacitor as close to the pin as possible.
- 2) Use of a regulator power supply is recommended.
- 3) Connecting a capacitive load to the output may cause oscillation.
- 4) Take particular care not to make capacitive coupling between the head amplifier input and the playback output. Also be careful not to make capacitive coupling between the recording input and the recording amplifier output.
- 5) Use of decoupling capacitors is recommended between the following DC voltage input pins and GND. When the control voltage source is at high impedance, aggravation of cross talk or oscillation may occur.

Pin 1 (YLEVEL),

Pin 31 (CLEVEL)

- 6) When a decoupling capacitor is necessary for other pins (not power supply pin), it is recommended to connect each decoupling capacitor as close to the pin as possible.
- 7) The voltage input to EVR adjusting pins should be proportional to the supply voltage V_{cc} . Control the input voltage in the range from 0 to 4.75 V when $V_{cc} = 4.75$ V.
For EVR adjustment at Pin 8 (RFAGCTC), control the input voltage in the range of 2.5 V to 4.75 V.

Characteristics Graphs

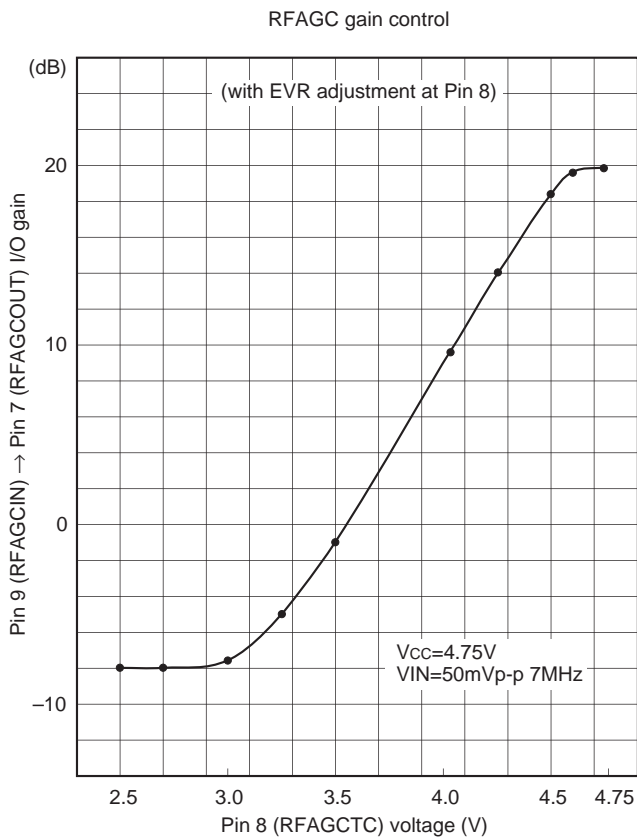
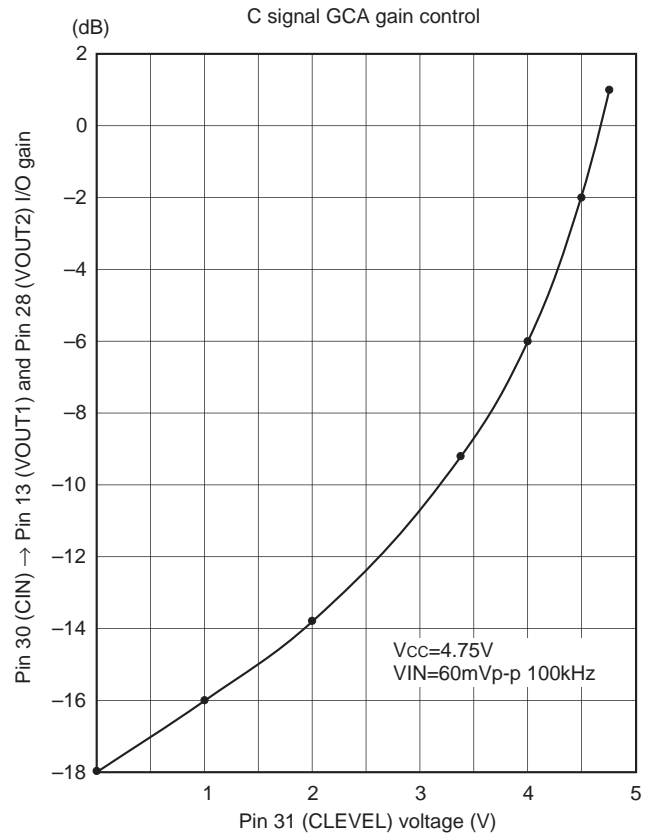
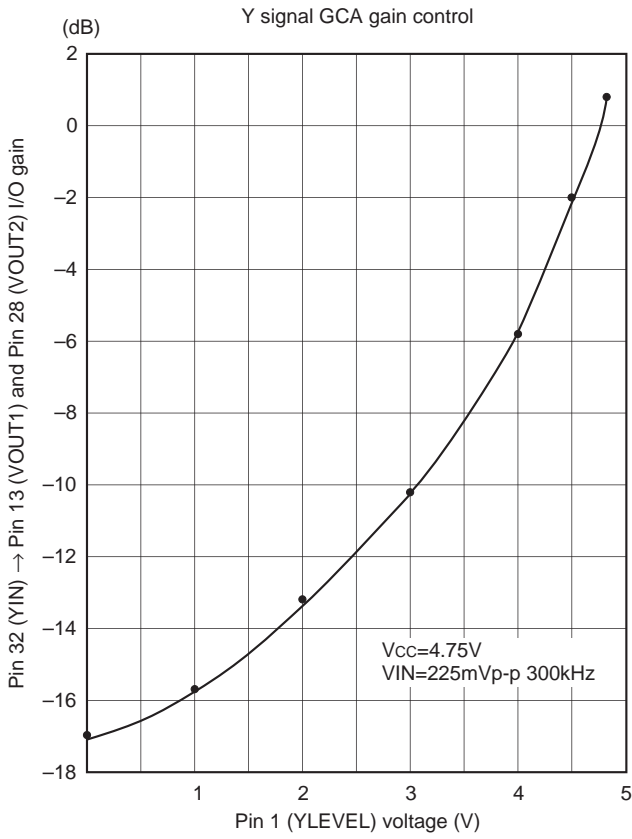

Package Outline Unit : mm

32PIN QFP (PLASTIC)

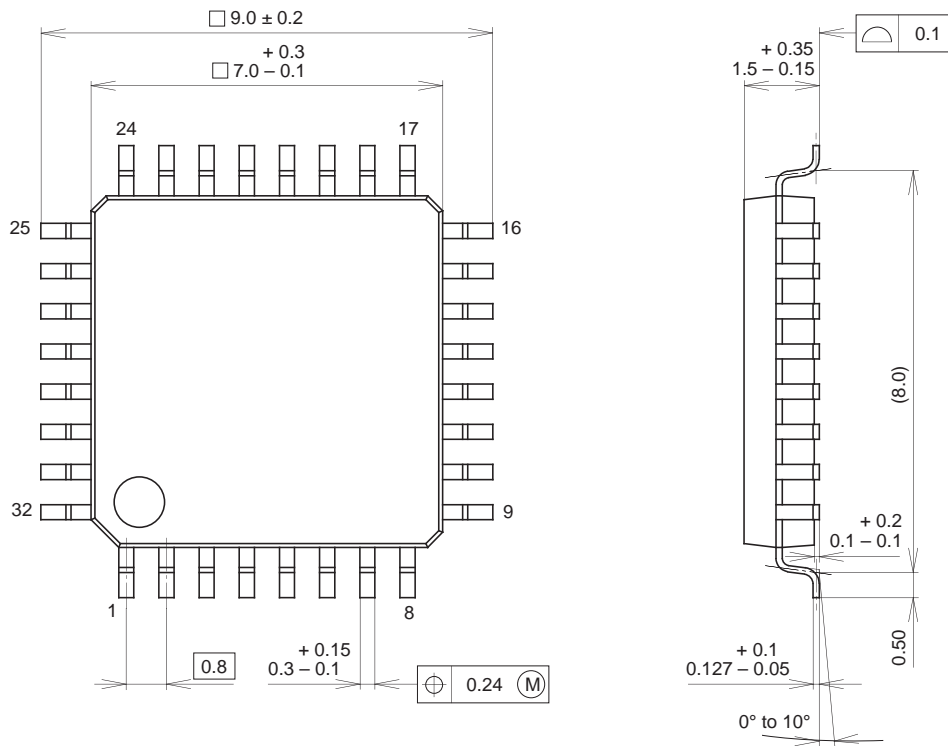

SONY CODE	QFP-32P-L01
EIAJ CODE	QFP032-P-0707
JEDEC CODE	_____

PACKAGE MATERIAL	EPOXY RESIN
LEAD TREATMENT	SOLDER PLATING
LEAD MATERIAL	42 ALLOY
PACKAGE MASS	0.2g



LittleDiode supplies new, hard to find or obsolete electronic components and semiconductors all over the world.

With over two million different components listed you are sure to find the part you need.

Feel free to visit us today at our online store:

LittleDiode.com

Looking forward to providing you with the best possible service.