

 **Dolby* S type Noise Reduction Processor**
Description

The CXA1917AM/AS is a bipolar IC designed for use in the Dolby S type noise reduction system (NR).

An external operational amplifier is required to configure the decoder. The stereo Dolby B-C-S type NR combines use of a CXA1563M/S and two CXA1917AM/AS ICs.

Features

- Considerable reduction in the number of external parts (half compared to CXA1417S/Q)
- The same Dolby level as that of CXA1560 series ICs (−6dBm)

Structure

Bipolar silicon monolithic IC

Absolute Maximum Ratings ($T_a = 25^\circ\text{C}$)

• Supply voltage	V_{CC} to V_{EE}	17	V
• Operating temperature	T_{opr}	−20 to +75	°C
• Storage temperature	T_{stg}	−65 to +150	°C
• Allowable power dissipation	P_D	(CXA1917AM) 600	mW
		(CXA1917AS) 1200	mW

Recommended Operating Conditions

Supply voltage	V_{CC}	4.5 to 6.5	V
	V_{EE}	−4.5 to −6.5	V

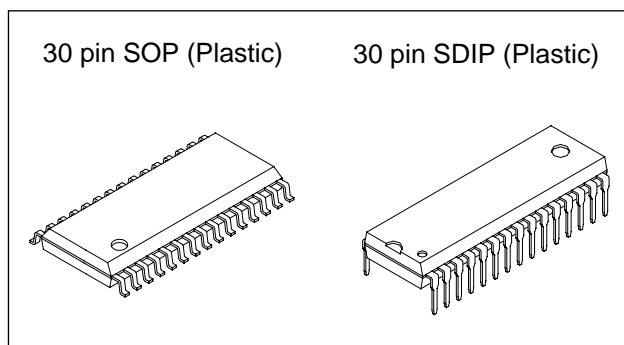

* This IC is available only to the licensees of Dolby Laboratories Licensing Corporation from whom licensing and applications information may be obtained.

* "Dolby" and the double D symbols are trademarks of Dolby Laboratories Licensing Corporation.

Sony reserves the right to change products and specifications without prior notice. This information does not convey any license by any implication or otherwise under any patents or other right. Application circuits shown, if any, are typical examples illustrating the operation of the devices. Sony cannot assume responsibility for any problems arising out of the use of these circuits.

Block Diagram and Pin Configuration (Encoder Unit)

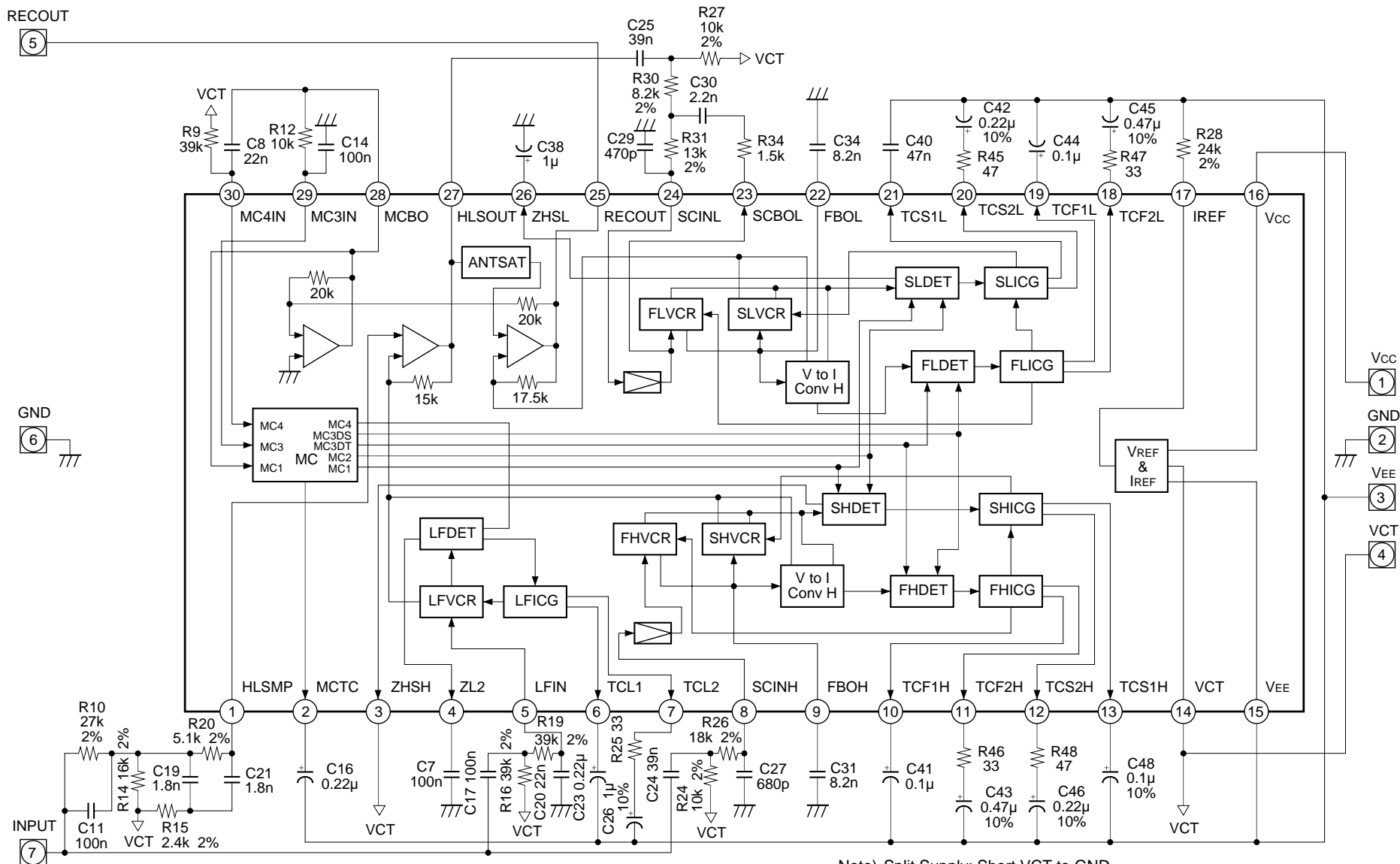

Note) Split Supply: Short VCT to GND
 Single Supply: Short GND to VEE and open VCT
 Tolerances of resistors are 5% without otherwise specified
 Tolerances of film capacitors are 5% without otherwise specified
 Tolerances of chemical capacitors are 20% without otherwise specified

Pin Description

(DCV values are for $V_{CC} = 6.0V$ and $V_{EE} = -6.0V$.)

Pin No.	Symbol	DCV (V)	Equivalent Circuit	Description
1	HLSMP	0		HLS main path input
2	MCTC	-3.9		Time constant for the MC2
3	ZHSH	0		DC cut capacitance for the HLS/HF/SB detector
4	ZL2	0		HF/LF/FB pass band rectifier input

Pin No.	Symbol	DCV (V)	Equivalent Circuit	Description
5	LFIN	0		HLS/LF/FB-stage input
6	TCL1	-4.6		Primary time constant for the HLS/LF/FB detector
7	TCL2	-4.6		Secondary time constant for the HLS/LF/FB detector
8	SCINH	0		HLS/HF side chain input

Pin No.	Symbol	DCV (V)	Equivalent Circuit	Description
9	FBOH	0		HLS/HF/FB VCR output
22	FBOL	0		LLS/HF/FB VCR output
10	TCF1H	0		Primary time constant for the HLS/HF/FB detector
11	TCF2H	-4.6		Secondary time constant for the HLS/HF/FB detector
18	TCF2L	-4.6		Secondary time constant for the LLS/HF/FB detector
12	TCS2H	-4.6		Secondary time constant for the HLS/HF/SB detector
20	TCS2L	-4.6		Secondary time constant for the LLS/FB/SB detector

Pin No.	Symbol	DCV (V)	Equivalent Circuit	Description
13	TCS1H	-4.6		Primary time constant for the HLS/HF/SB detector
14	VCT	0		For dual power supply: Ground For single power supply: VCT
15	V _{EE}	-6.0		For dual power supply: Negative power supply For single power supply: Ground
16	V _{CC}	6.0		Positive power supply
17	IREF	-4.8		Reference current input
19	TCF1L	-4.6		Primary time constant for the LLS/HF/FB detector

Pin No.	Symbol	DCV (V)	Equivalent Circuit	Description
21	TCS1L	-4.6		Primary time constant for the LLS/HF/SB detector
23	SCBOL	0		LLS/HF side chain buffer amplifier output
24	SCINL	0		LLS/HF side chain input
25	RECOUT	0		Recording (encoding) output
28	MCBO	0		MC buffer feedback
26	ZHSL	0		DC cut capacitance for the LLS/HF/SB detector

Pin No.	Symbol	DCV (V)	Equivalent Circuit	Description
27	HLSOUT	0		HLS output
29	MC3IN	0		MC3 input
30	MC4IN	0		MC4 input

Electrical Characteristics (Ta = 25°C, Dolby level: -6dBm (= 388mVrms) at encoder input, Vcc = +6V, VEE = -6V)

Characteristics	Symbol	Measurement conditions			Min.	Typ.	Max.	Unit
		f (kHz)	Input	Other				
Operating voltage	VOPR	1	15dB	THD ≤ 1%	±4.5		±6.5	V
Current consumption	Icc			No signal	10.0	15.0	20.0	mA
Encoding characteristics (boost)								
(1)	EB-1	2	-60		22.0	23.5	25.0	dB
(2)	EB-2	0.05	-40		5.9	7.4	8.9	dB
(3)	EB-3	0.3	-40		15.0	16.5	18.0	dB
(4)	EB-4	12	-40		12.8	14.3	15.8	dB
(5)	EB-5	0.3	-20		6.7	8.2	9.7	dB
(6)	EB-6	2	-20		4.4	5.9	7.4	dB
(7)	EB-7	0.05	0		-2.9	-1.4	0.1	dB
(8)	EB-8	12	0		-7.3	-5.8	-4.3	dB
Signal handling	Vomax	1		THD = 1%	14.0	16.0	—	dB
Total harmonic distortion	THD	1	0		—	0.01	0.15	%
S/N ratio	SNR			Rg = 600Ω CCIR/ARM	62.0	65.0	—	dB

Electrical Characteristics Measurement Circuit

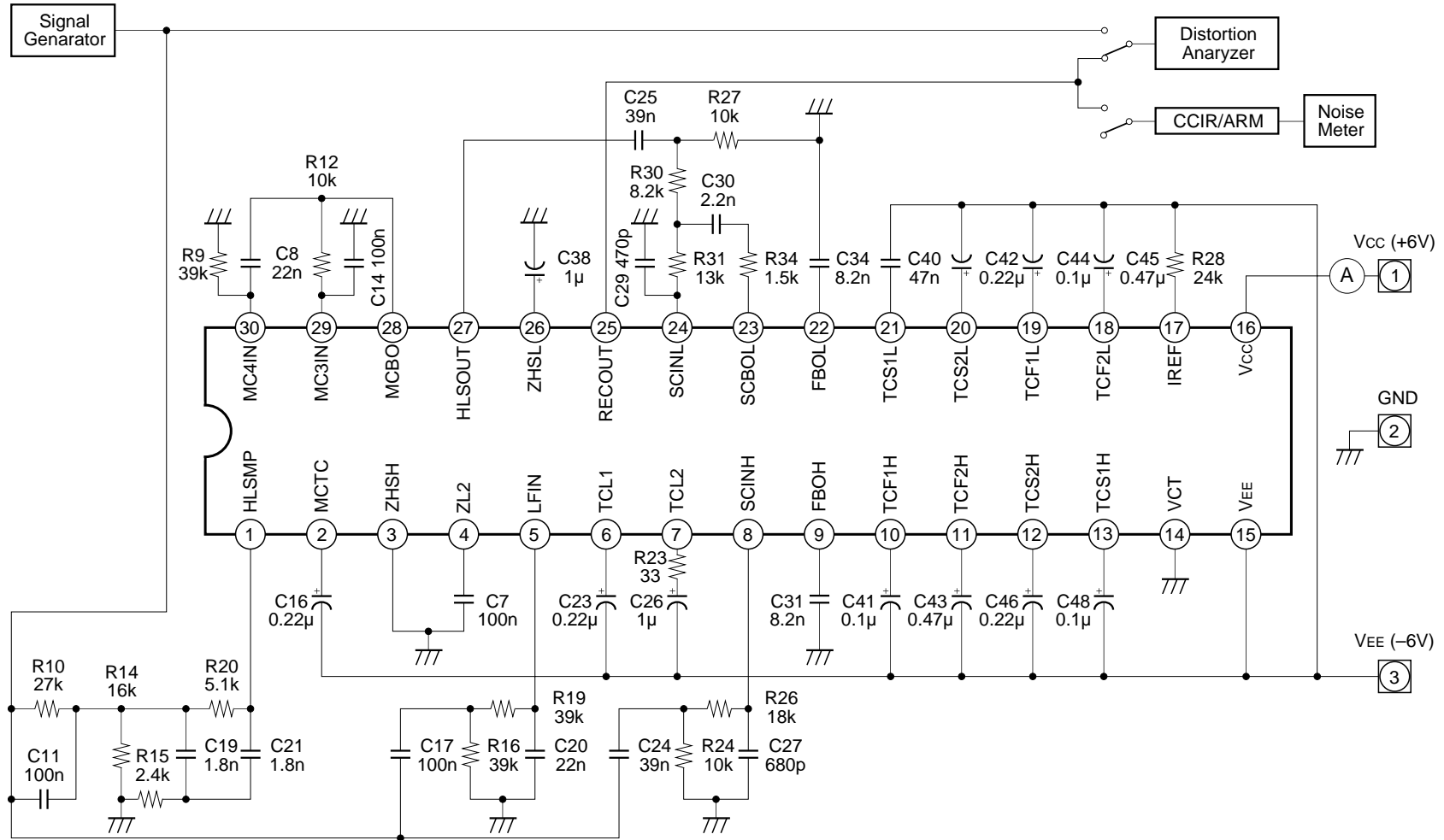

Application Circuit

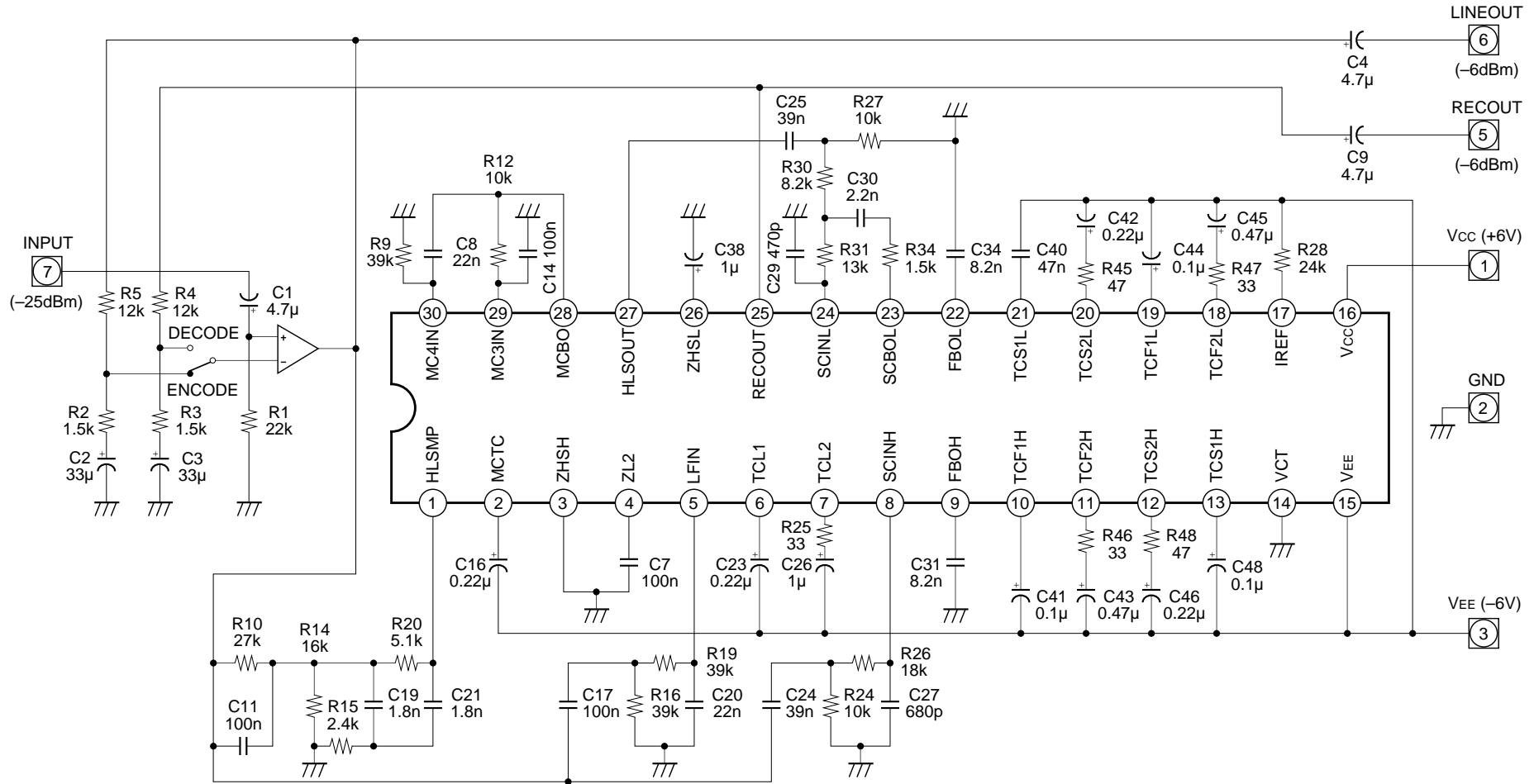

- 11 -

Application circuits shown are typical examples illustrating the operation of the devices. Sony cannot assume responsibility for any problems arising out of the use of these circuits or for any infringement of third party patent and other right due to same.

Notes on Application

The CXA1917A is an encoding IC for the Dolby S type (NR). An external operational amplifier is required to configure the decoder circuit. The Dolby level voltage of this IC is designed to be -6dBm (388mVrms), which is the same as that of the CXA1562 and CXA1563 Dolby B-C type ICs. Therefore, it is possible to use the CXA1562 or the CXA1563 to configure a B-C-S type switchable processor. The B-C-S type switchable processor can be configured without requiring an external operational amplifier because the CXA1563 has a built-in S-type changeover switch.

Power Supply

The CXA1917A will operate with either dual or single power supply. Connect VCT pin to GND pin when dual power supply is used. Connect V_{EE} pin to GND pin and open VCT pin when a single power supply is used. The power supply half the V_{CC} generated inside the IC is generated at VCT pin.

The supply voltage range is from $\pm 4.5\text{V}$ to $\pm 6.5\text{V}$ and from 9V to 13V for dual and single power supplies, respectively. Note, however, that the minimum supply voltage is determined by the maximum voltage amplitude of external operational amplifier. Because general-purpose operational amplifiers have the maximum voltage amplitude of approximately $(V_{CC} - V_{EE}) - 2\text{V}$, actual minimum supply voltages, which satisfy the 15dB overload margin, are $\pm 5.0\text{V}$ and 10V for dual and single power supplies, respectively. The supply current does not depend so much on the supply voltage, but does depend on the signal level and frequency. The maximum supply current in the worst case is approximately 25mA .

Recording Processor

Fig. 1 shows the recording processor. The gain is defined as follows:

$$\text{GREC20} \cdot \text{Log} (1 + R62/R63) \dots\dots (1)$$

The processor in Fig. 1 has a gain of 14dB , therefore, input sensitivity is -20dBm (77.5mVrms). An input sensitivity higher than -25dBm (44mVrms) is generally unacceptable due to noise performance, although this is affected by the operational amplifier in the input circuit. An important characteristic for the external operational amplifier is the noise performance for approximately an input impedance of $20\text{k}\Omega$. A bipolar input type will be better than the JFET input type for the recording processor.

Playback Processor

Fig. 2 shows the playback processor. The gain is defined as follows:

$$\text{GPB20} \cdot \text{Log} (1 + R64/R65) \dots\dots (2)$$

The processor in Fig. 2 has a gain of 20dB , therefore, the input sensitivity is -26dBm (39mVrms). Important characteristics of the playback processor are the frequency response and the feedback loop stability, which depend on the gain of the feedback loop gain and the slew rate of the external operational amplifier. The slew rate has to be higher than $3\text{V}/\mu\text{s}$. The loop gain can be estimated using the gain bandwidth product BG (Hz) of the operational amplifier and the decode gain APB . The lower limit of BG/APB is approximately 500kHz , and the recommended range is from 1 to 3MHz .

Switchable Processor

Fig. 3 shows the switchable processor. The gains are the same as in equations (1) and (2). An operational amplifier is required with low noise, average slew rate ($> 3\text{V}/\mu\text{s}$), and wide bandwidth ($\approx 10\text{MHz}$) for this gain setting. A bipolar input type operational amplifier with a wide bandwidth like those of the 4560 and the 4570 is required of the switchable processor.

The processor in Fig. 3 may generate a significant switching noise, especially when S2 switch is make-break-make type. When S2 switch is a make-to-make type or has a quick switching feature, the switching noise will be within the range acceptable for cassette decks with output muting circuits.

B-C-S Type Switchable Stereo Processor

Fig. 4 shows the stereo processor switchable to any B-C-S type mode. The operational amplifier is unnecessary, because the CXA1563 is used for a B-C type processor and S-type changeover switch is built in the IC. It is recommended that the S type mode be used for recording level calibration.

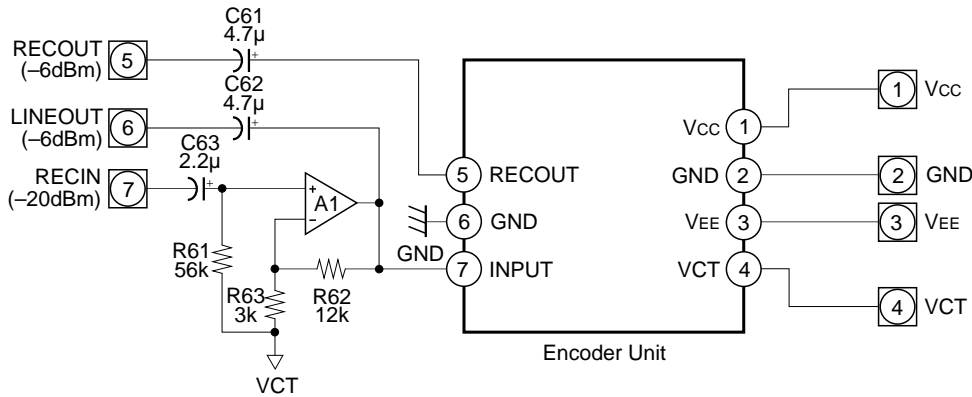

Fig. 1. Recording Processor

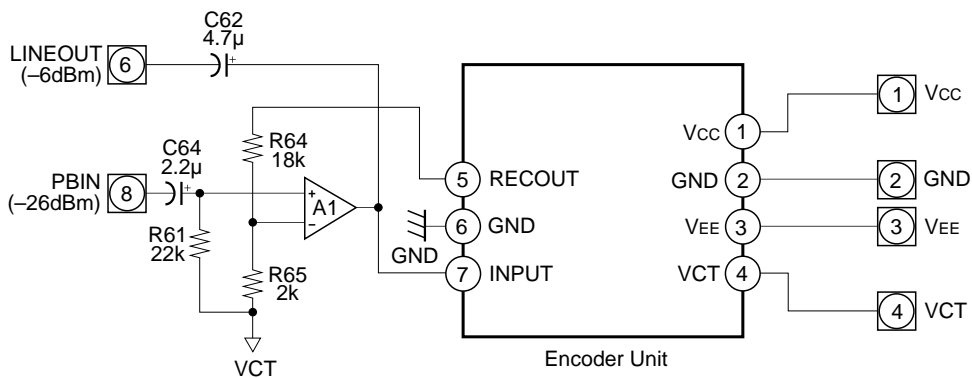

Fig. 2. Playback Processor

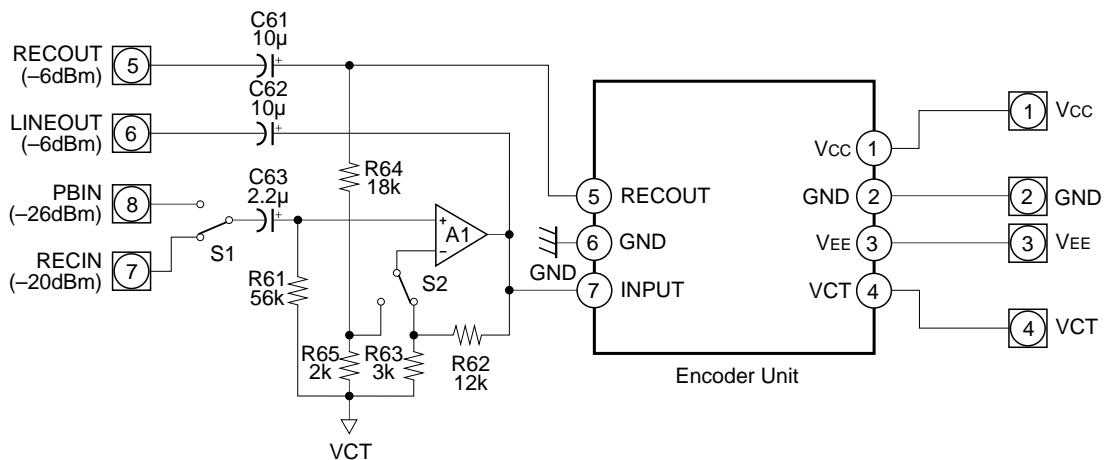

Fig. 3. Switchable Processor

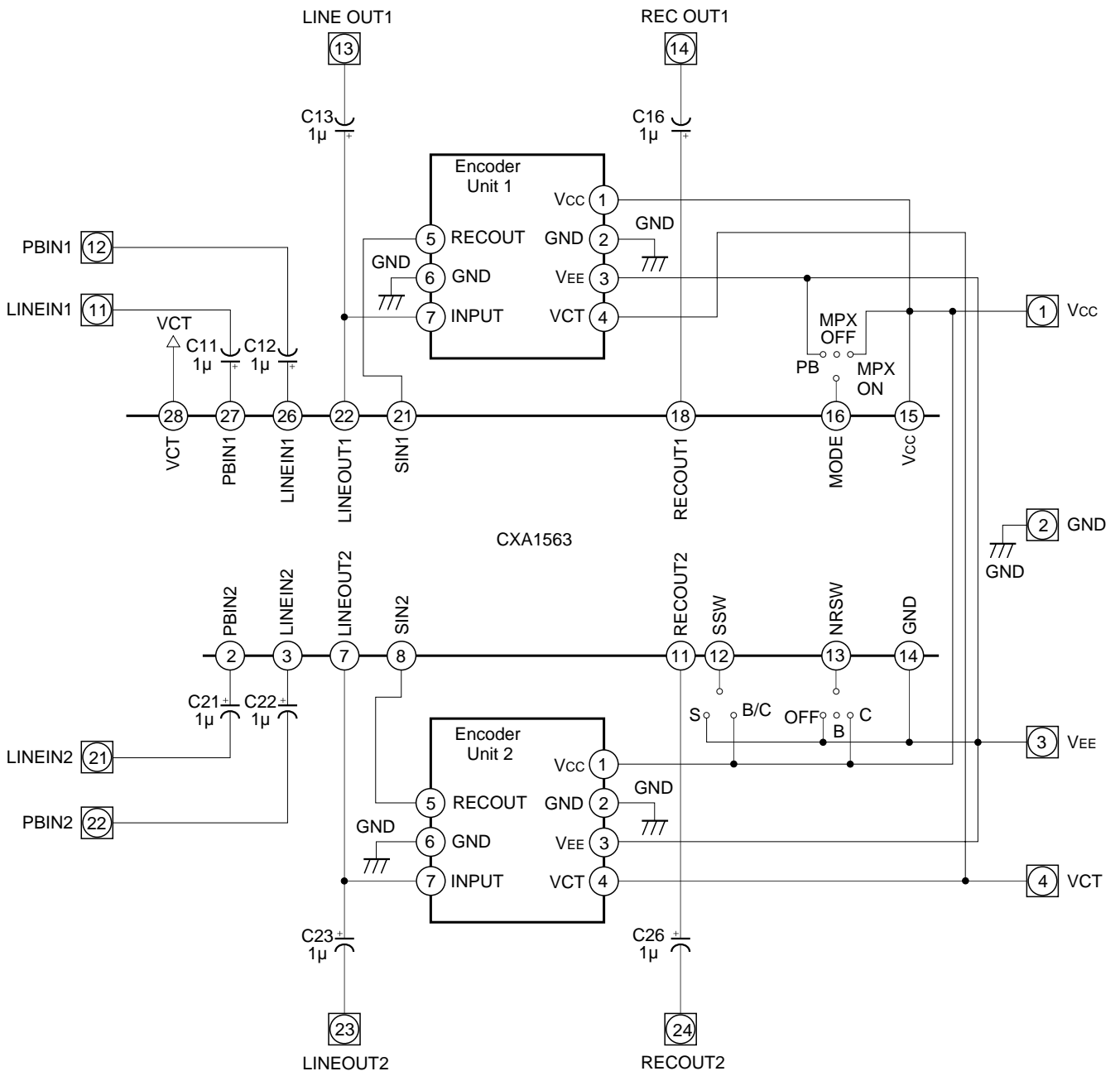
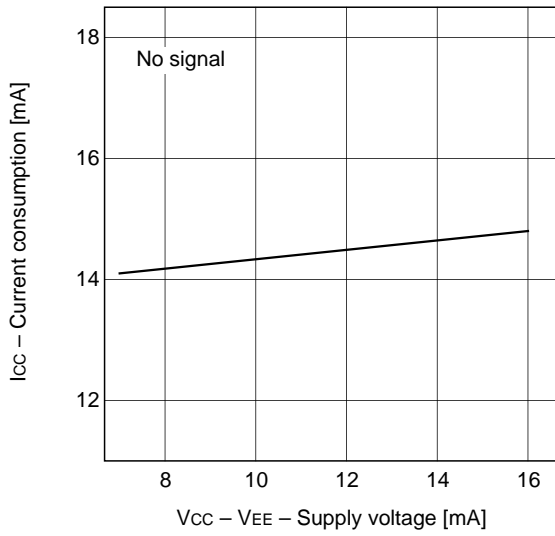

Fig. 4. B-C-S Switchable Stereo Processor

Example of Representative Characteristics

Current consumption vs. Supply voltage



Current consumption vs. Input level

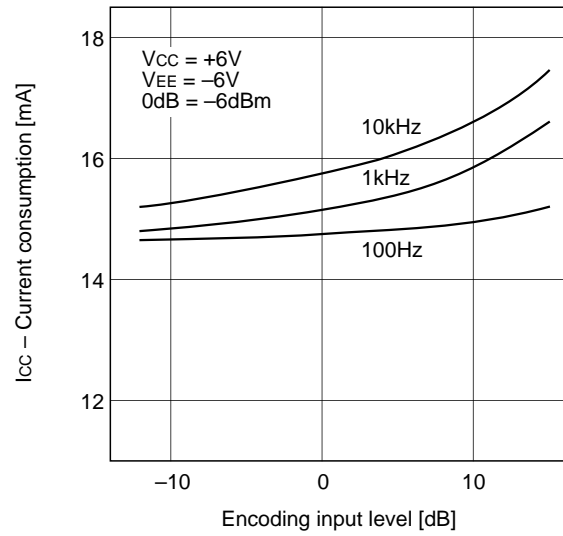

Encoding characteristics

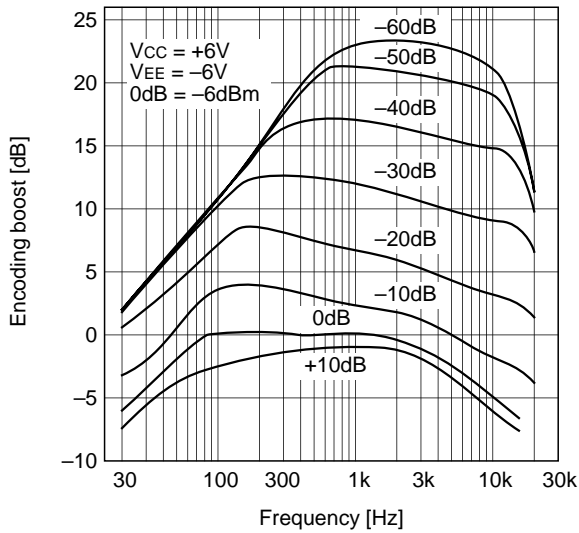

Total harmonic distortion characteristics

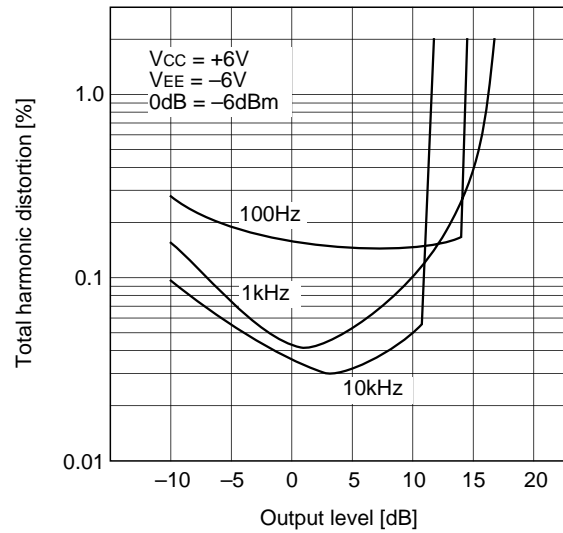

Overload margin vs. Supply voltage

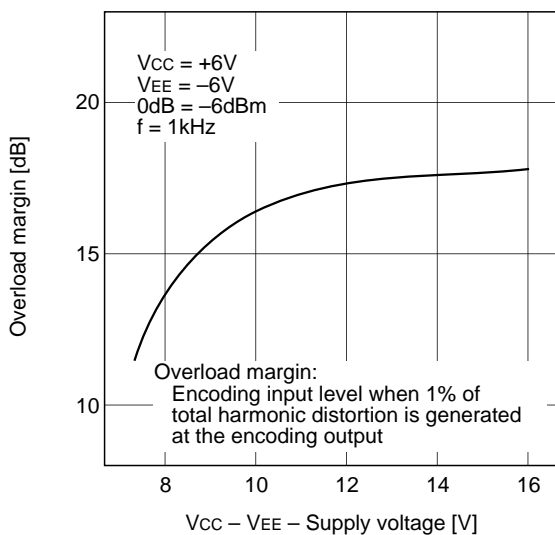

Ripple rejection

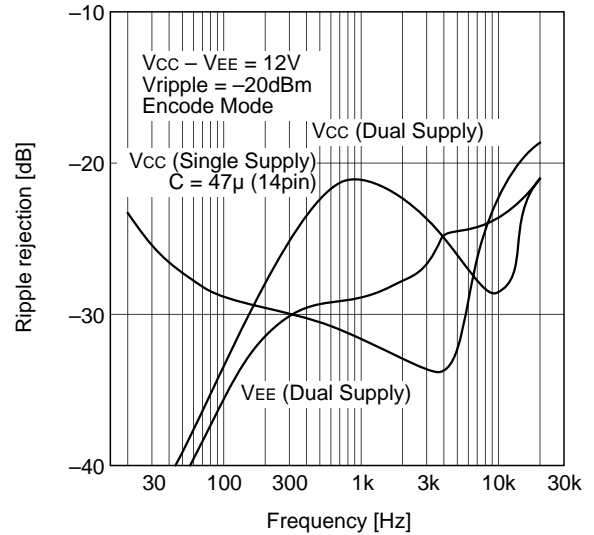

Package Outline Unit: mm

CXA1917AM

30PIN SOP (PLASTIC)

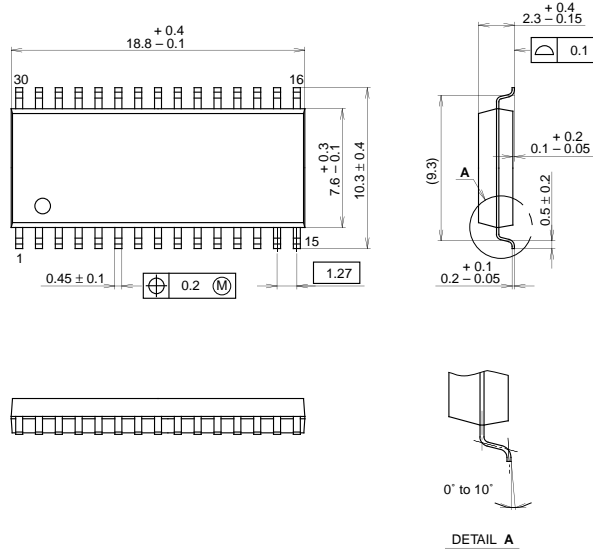

SONY CODE		PACKAGE STRUCTURE	
SONY CODE	SOP-30P-L03	PACKAGE MATERIAL	EPOXY RESIN
EIAJ CODE	SOP030-P-0375	LEAD TREATMENT	SOLDER PLATING
JEDEC CODE		LEAD MATERIAL	COPPER ALLOY
		PACKAGE MASS	0.7g

30PIN SOP (PLASTIC)

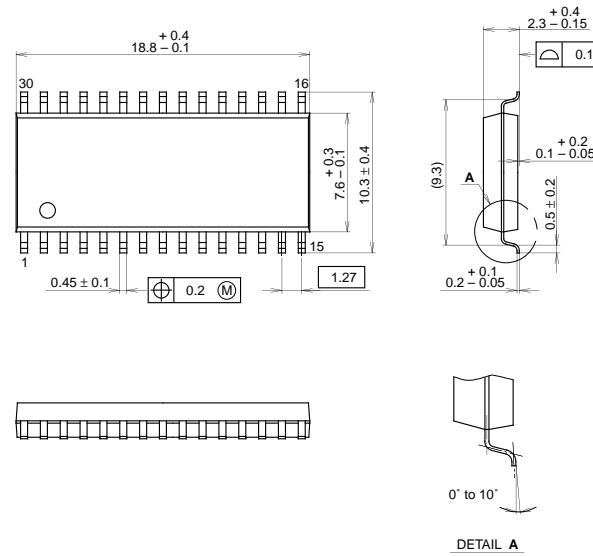

SONY CODE		PACKAGE STRUCTURE	
SONY CODE	SOP-30P-L03	PACKAGE MATERIAL	EPOXY RESIN
EIAJ CODE	SOP030-P-0375	LEAD TREATMENT	SOLDER PLATING
JEDEC CODE		LEAD MATERIAL	COPPER ALLOY
		PACKAGE MASS	0.7g

LEAD PLATING SPECIFICATIONS

ITEM	SPEC.
LEAD MATERIAL	COPPER ALLOY
SOLDER COMPOSITION	Sn-Bi Bi:1-4wt%
PLATING THICKNESS	5-18μm

Package Outline Unit: mm

CXA1917AS

30PIN SDIP (PLASTIC)

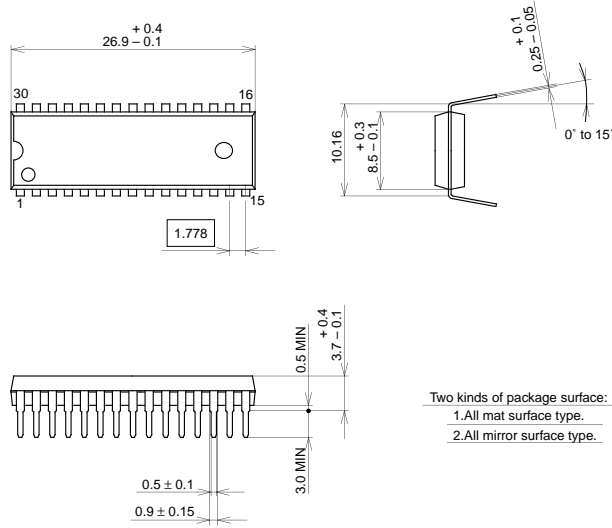

Two kinds of package surface:
 1. All mat surface type.
 2. All mirror surface type.

PACKAGE STRUCTURE

SONY CODE	SDIP-30P-01
EIAJ CODE	P-SDIP30-8.5x26.9-1.778
JEDEC CODE	

MOLDING COMPOUND	EPOXY RESIN
LEAD TREATMENT	SOLDER PLATING
LEAD MATERIAL	COPPER ALLOY
PACKAGE MASS	1.8g

30PIN SDIP (PLASTIC)

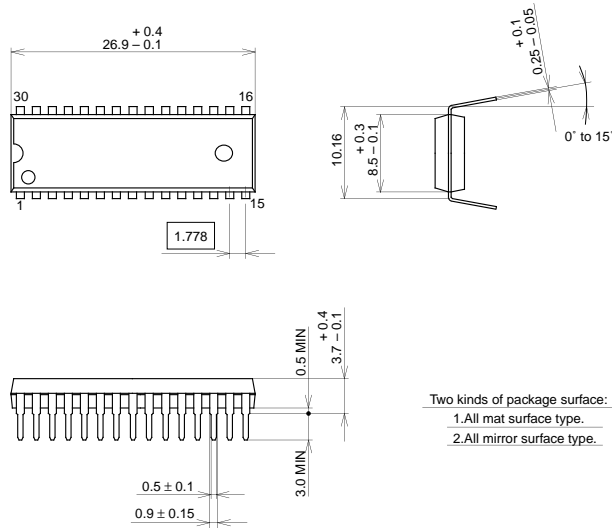

Two kinds of package surface:
 1. All mat surface type.
 2. All mirror surface type.

PACKAGE STRUCTURE

SONY CODE	SDIP-30P-01
EIAJ CODE	P-SDIP30-8.5x26.9-1.778
JEDEC CODE	

MOLDING COMPOUND	EPOXY RESIN
LEAD TREATMENT	SOLDER PLATING
LEAD MATERIAL	COPPER ALLOY
PACKAGE MASS	1.8g

LEAD PLATING SPECIFICATIONS

ITEM	SPEC.
LEAD MATERIAL	COPPER ALLOY
SOLDER COMPOSITION	Sn-Bi Bi:1-4wt%
PLATING THICKNESS	5-18μm



LittleDiode supplies new, hard to find or obsolete electronic components and semiconductors all over the world.

With over two million different components listed you are sure to find the part you need.

Feel free to visit us today at our online store:

LittleDiode.com

Looking forward to providing you with the best possible service.