

I-V Photo IC for MiniDisc

Description

The CXA1915AN is a photo IC developed as a photo detector for the optical pickup of MiniDisc. The photodiode for RF signal detection has a built-in I-V amplifier and features low output impedance for stable output.

- Focus servo: astigmatic method
- Tracking servo: three-spot method
- Magneto optical signal (RF signal) detection: Wollaston prism method

Features

- I-V amplifier (current-voltage conversion circuit)
- Ultra-compact transparent molded package (SSOP)

Applications

Optical pickup for MiniDisc

Structure

Bipolar silicon monolithic IC

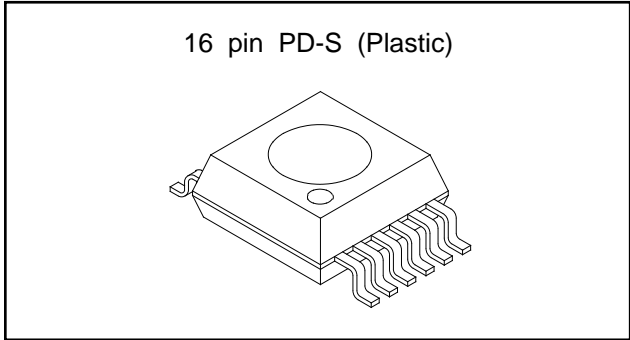

Absolute Maximum Ratings (Ta=25°C)

- Supply voltage VCC 6 V
 - Operating temperature Topr -20 to 90 °C
 - Storage temperature Tstg -40 to 90 °C
 - Allowable power dissipation
- | | | |
|----|-----|----|
| Pd | 150 | mW |
|----|-----|----|

Recommended Operating Conditions

- Supply voltage VCC 2.5 to 5.5 V

Sony reserves the right to change products and specifications without prior notice. This information does not convey any license by any implication or otherwise under any patents or other right. Application circuits shown, if any, are typical examples illustrating the operation of the devices. Sony cannot assume responsibility for any problems arising out of the use of these circuits.

Photo Detector Pattern Dimensions

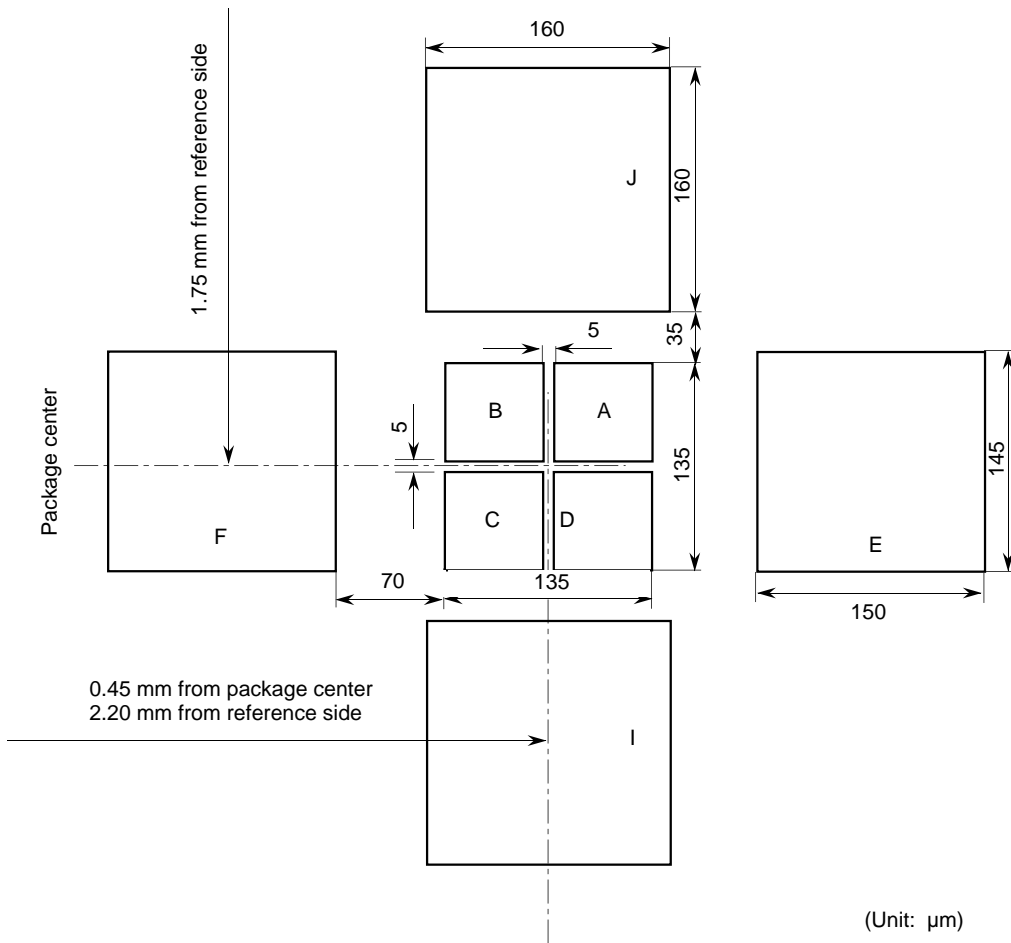

Circuit Block Diagram

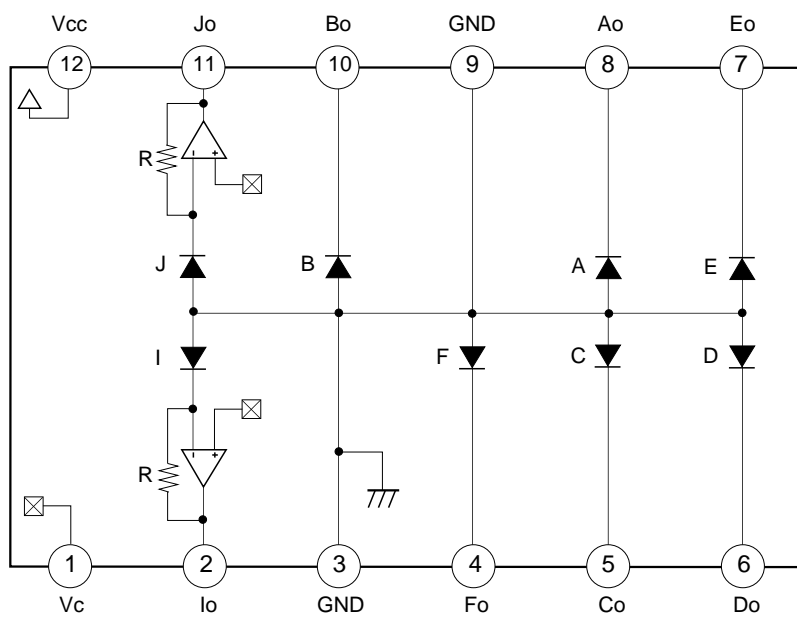

R=115k Ω

A, B, C, D, E, F, I, and J are photodiodes.

Electrical and Optical Characteristics

(VCC=3.0V, Vc=1.5V, Ta=25°C)

Item	Symbol	Conditions	Min.	Typ.	Max.	Unit
Current consumption	I _{CC}	In the dark		2.2	3.2	mA
Dark current (A to F)	I _D	In the dark			4.0	nA
Optical sensitivity (A to F)	S	P _O =5μW, λ = 780nm	0.3	0.4		A/W
Output offset voltage (I, J)	V _{off}	In the dark	-10	5.5	10	mV
Output offset voltage difference (I-J)	ΔV _{off}	In the dark	-10	0	10	
Output voltage (I, J)	V _O	P _O =5μW, λ = 780nm	100	130	160	
Maximum output voltage (I, J)	V _{omax}	P _O =100μW, λ = 780nm	2.7	2.8		V
Frequency response (I, J)	f _c	100kHz reference, -3 dB	1.8	2.3		MHz

Note)

1. V_c is reference for output voltage and output offset voltage.
2. GND is reference for maximum output voltage.
3. Output voltage and frequency response are subject to conformation of design.

Measurement Circuit

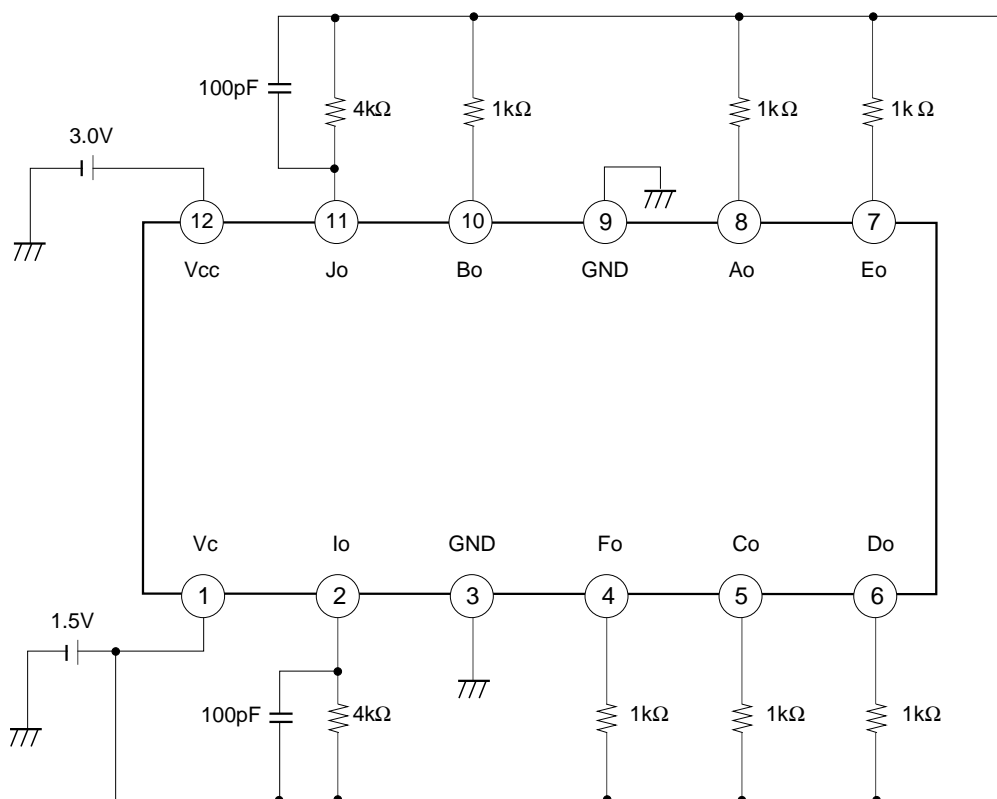
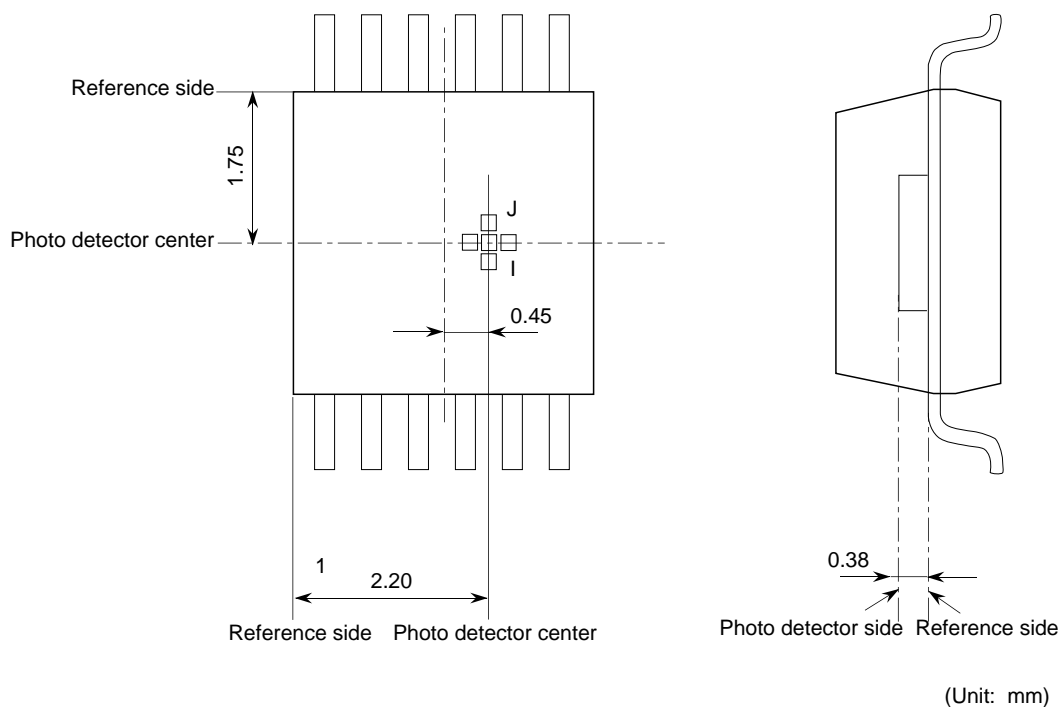

Photo Detector Position



Accuracy in position of photo detector (the reference side shown above is reference.)

X, Y : ± 0.2 mm

Z : ± 0.2 mm

θ : $\pm 2^\circ$

Example of Representative Characteristics

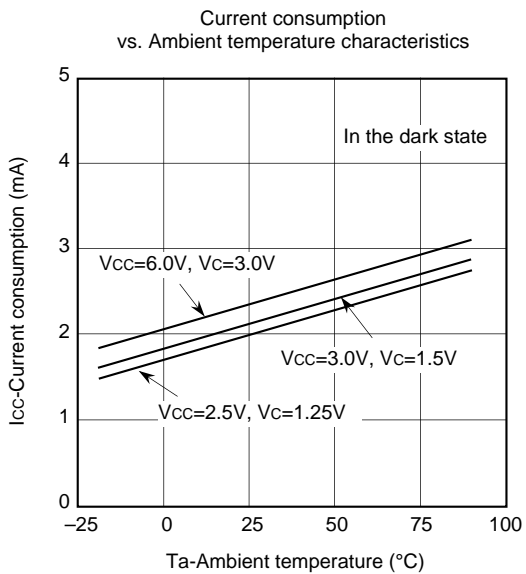
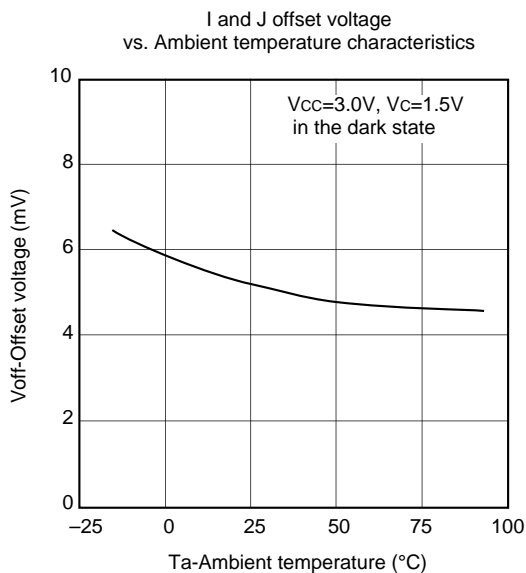
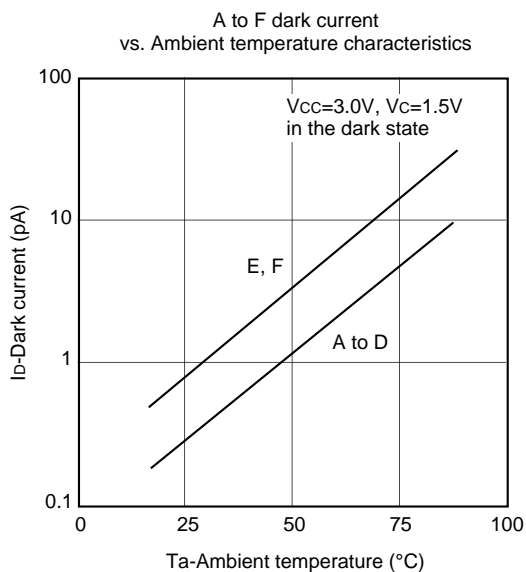

Pin Description

Pin No.	Symbol	I/O	Equivalent circuit	Description
1	Vc	I		<p>For a dual positive/negative power supply: GND</p> <p>For a single power supply: center voltage input</p>
2 11	Io Jo	O		<p>Output of electrical signals converted from optical signals</p>
3 9	GND	I		<p>For a dual positive/negative power supply: negative power supply</p> <p>For a single power supply: GND</p>
4 5 6 7 8 10	Fo Co Do Eo Ao Bo	O		<p>Output of electrical signals converted from optical signals (cathode pin of photodiode)</p>
12	Vcc	I		<p>Positive power supply</p>

Notes on Operation

1. Connection to RF amplifiers

In the CXA1915AN, the RF signals (I, J) are of the voltage-output type. Therefore, the RF amplifier should have an I-V amplifier at the input block because the servo signals (A to F) are of current-output type.

2. Power supply

The CXA1915AN can be used either with a dual positive/negative power supply or with a single power supply. However, this IC is not provided with a center voltage generating circuit, and so when used with a single power supply the center voltage must be supplied by an RF amplifier or some other device.

Power supply connections for each case are as follows.

	(12) Vcc	(3) (9) GND	(1) Vc
Dual positive/ negative power supply	Positive power supply	Negative power supply	GND
Single power supply	Positive power supply	GND	Center voltage

Note) Pins 3 and 9 are shorted in the IC.

For both a dual positive/negative power supply and a single power supply, the voltage difference between the Vcc and GND pins should be within the range of 2.5 V and 5.5 V.

Package Outline Unit : mm

PD-S-16

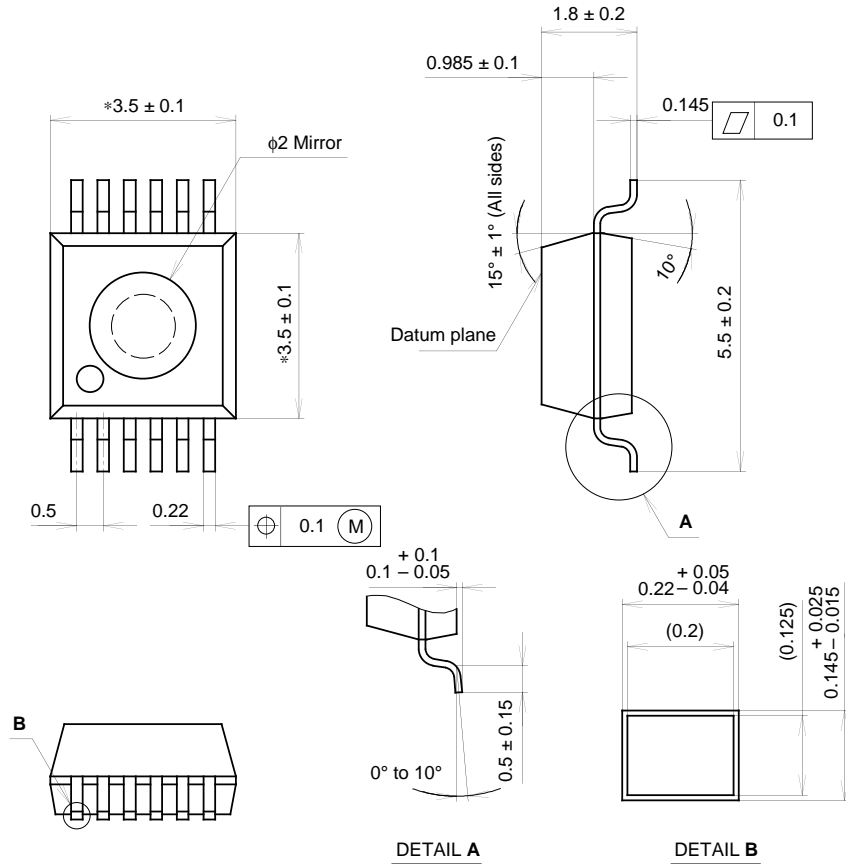

NOTE: Dimension "*" does not include mold protrusion.

SONY CODE	PD-S-16
EIAJ CODE	_____
JEDEC CODE	_____

PACKAGE WEIGHT	0.04g
----------------	-------



LittleDiode supplies new, hard to find or obsolete electronic components and semiconductors all over the world.

With over two million different components listed you are sure to find the part you need.

Feel free to visit us today at our online store:

LittleDiode.com

Looking forward to providing you with the best possible service.