

DD Dolby B/C Type Noise Reduction System with Playback Equalizer

Description

The CXA1911Q is an IC designed for use in car stereo cassette decks. Functions include Dolby B/C type noise reduction, playback equalizer amplifier and music sensor into a single chip.

Features

- Few external parts
- Forward/Reverse head switching
- Small package (40-pin QFP)
- Dolby B/C type noise reduction and playback equalizer into a single chip
- Same pin configuration as Dolby B type noise reduction system (CXA1910Q)
- Music sense level can be set by external resistors/capacitors (2 modes).
- High-band cut filter frequency can be adjusted by the external capacitance.

Applications

- Car stereo cassette decks
- Cassette decks (playback only)

Structure

Bipolar silicon monolithic IC

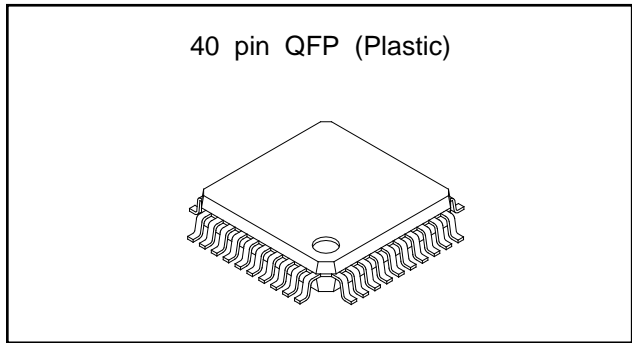

Absolute Maximum Ratings (Ta=25°C)

- Supply voltage VCC 12 V
- Operating temperature Topr -40 to +85 °C
- Storage temperature Tstg -65 to +150 °C
- Allowable power dissipation PD 430 mW

Recommended Operating Conditions

- Supply voltage VCC 7.8 to 11 V

* These ICs are available only to the licensees of Dolby Laboratories Licensing Corporation from whom licensing and applications information may be obtained.
 * "Dolby" and the double D symbols are trade marks of Dolby Laboratories Licensing Corporation.
 * Sony reserves the right to change products and specifications without prior notice. This information does not convey any license by any implication or otherwise under any patents or other right. Application circuits shown, if any, are typical examples illustrating the operation of the devices. Sony cannot assume responsibility for any problems arising out of the use of these circuits.

Block Diagram

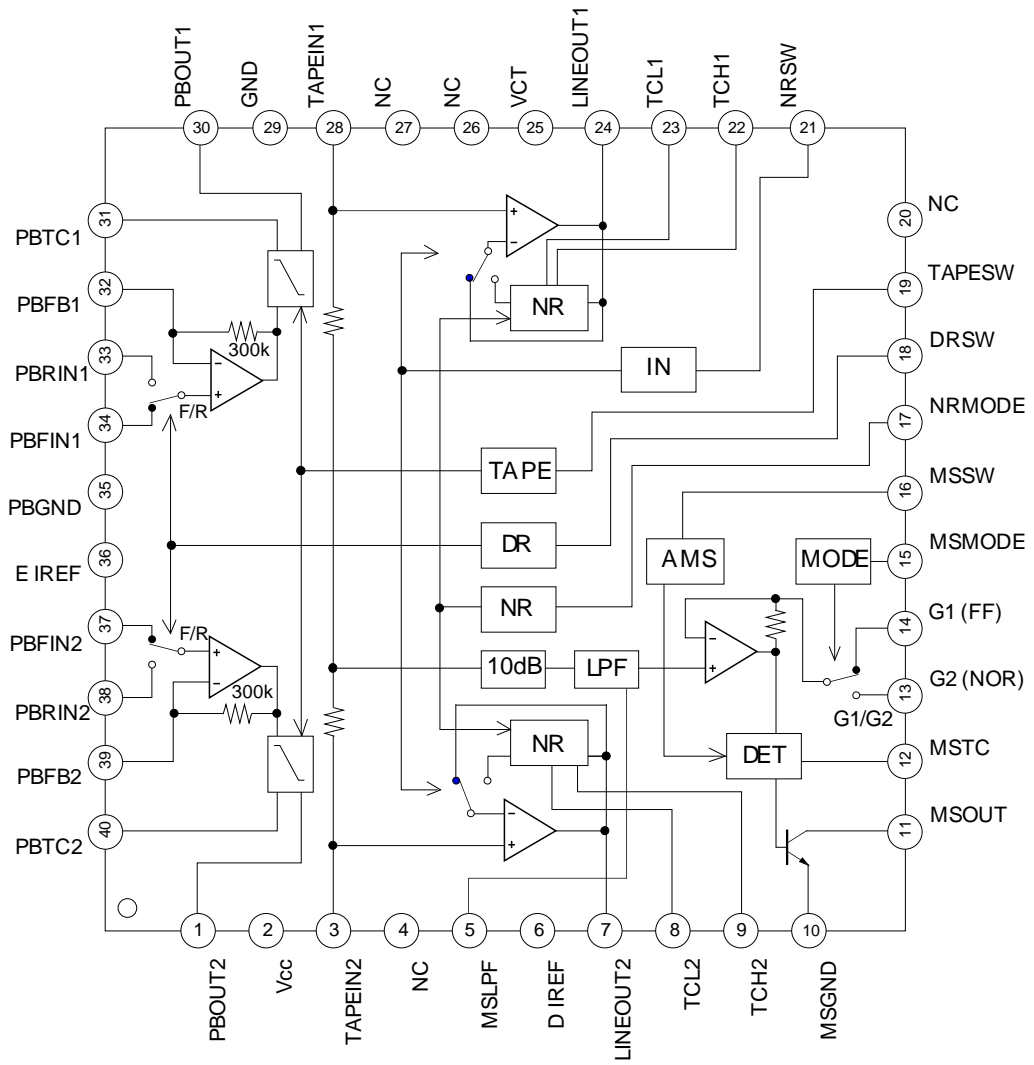

Pin Description

(Ta=25°C, Vcc=8.0V, no signal)

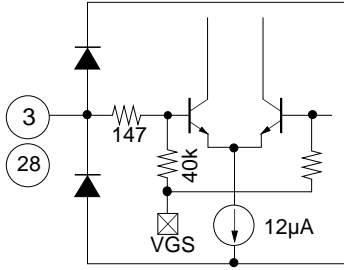
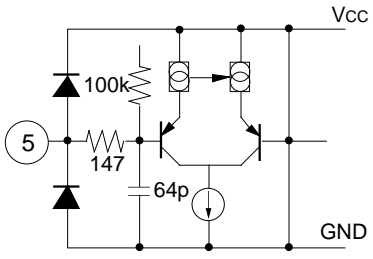
Pin No.	Symbol	DC value	Z (in)	Equivalent circuit	Description
1 30	PBOUT	2.1V	—	Refer to Page 7.	PBEQ output
32 39	PBFB	2.1V	300kΩ		PBEQ feedback
33 34 37 38	PBIN	0V	—		PBEQ input
2	Vcc	8.0V	—	_____	Power supply
3 28	TAPEIN	4.0V	40kΩ		TAPE input
4 20 26 27	NC	—	—		No connection
5	MSLPF	4.0	100kΩ		Adjustment of MS LPF frequency

Pin No.	Symbol	DC value	Z (in)	Equivalent circuit	Description
6	D IREF	1.25V	—		Connection of reference current setting resistor for Dolby block
7 24	LINEOUT	4.0V	—		Line output
8 23	TCL	0.3V	—		Time Constant pin for the LLS
9 22	TCH	0.3V	—		Time Constant pin for the HLS
10 29 35	MSGND GND PBGND	0.0V	—		Ground

Pin No.	Symbol	DC value	Z (in)	Equivalent circuit	Description
11	MSOUT	0.2 V for signal detection; 5.0 V for no signal detection	—		MS output
12	MSTC	Approx. 1.4 V for signal detection; 5.0 V for no signal detection	—		Connection of MS detection time constant
13 14	G2(NOR) G1(FF)	4.0V	—		MS feedback
15	MSMODE	—	—		MSMODE MS gain selector G1 when high, G2 when low
18	DRSW				DRSW Head selector Reverse when high, Forwards when low
19	TAPESW				TAPESW Equalizer selector 120µs when high, 70µs when low
21	NRSW				NRSW NR ON/OFF selector
16	MSSW	—	—		MS on/off selector MS on when high, MS off when low

Pin No.	Symbol	DC value	Z (in)	Equivalent circuit	Description
17	NRMODE	—	—		Noise reduction selector C when high, B when low
25	VCT	4.0V	—		Vcc/2 output
31 40	PBTC	—	—		PBEQ capacitance
36	E IREF	1.25V	—		Connection of reference current setting resistor for PBEQ block

• PBOUT, PBFB, PBIN equivalent circuit

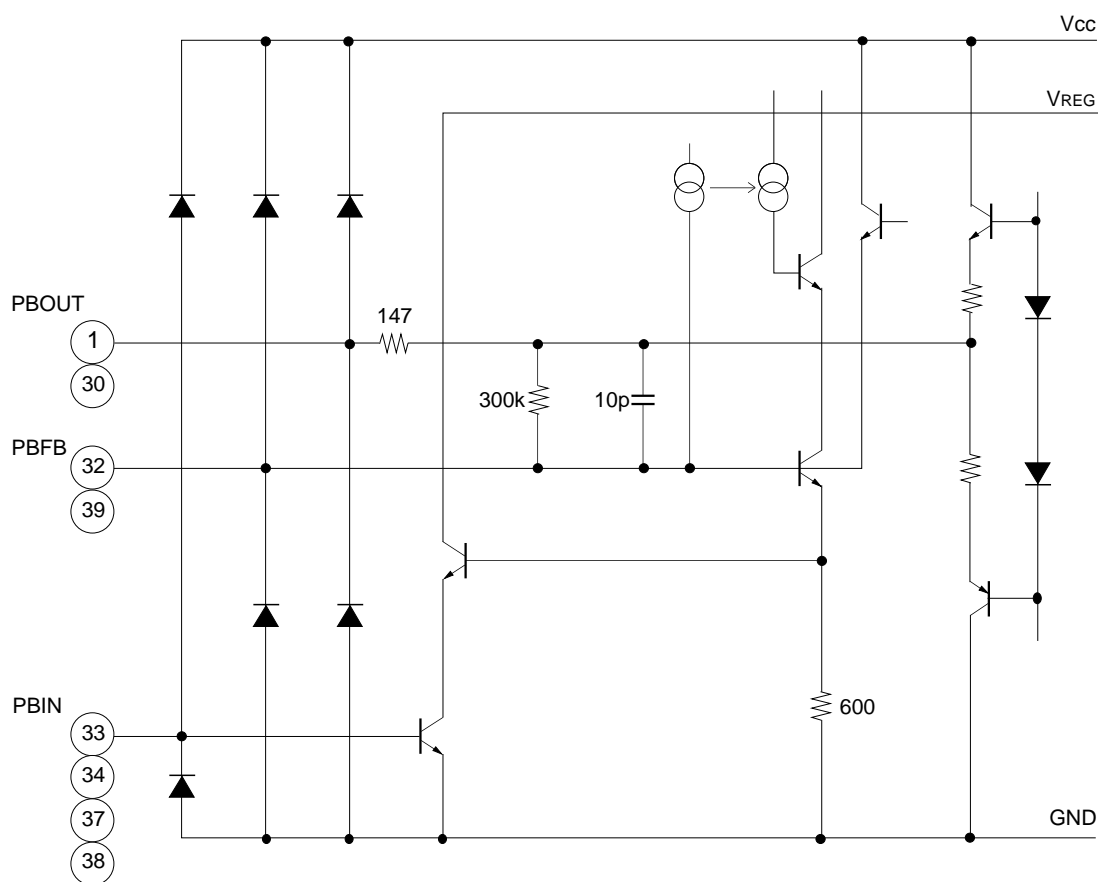

Electrical Characteristics (Ta=25°C, Vcc=8.0 V, RL: output load resistance, Rg: head equivalent impedance; unless otherwise specified, 120 μs, FWD mode, NR OFF, MS OFF)

Item	Symbol	Measurement conditions (input pin, input level frequency etc.)	Min.	Typ.	Max.	Unit
Operating voltage	Vopr		7.8	8.0	11.0	V
Current consumption	Icc	No signal	18.5	21.9	25.5	mA
Dolby block (Dolby level -6 dBm=0 dB)						
TAPE IN input sensitivity	VTIN	LINE OUT=0dB 1kHz	-32.0	-30.0	-28.0	dBm
NR B decode boost 1	BP1	500Hz, LINE OUT -25dB, NR B, TAPE IN	1.4	3.4	4.4	dB
NR B decode boost 2	BP2	2kHz, LINE OUT -25dB, NR B, TAPE IN	5.5	6.0	8.5	
NR B decode boost 3	BP3	5kHz, LINE OUT -25dB, NR B, TAPE IN	3.9	5.1	6.9	
NR B decode boost 4	BP4	10kHz, LINE OUT -40dB, NR B, TAPE IN	9.7	10.2	11.9	
NR B decode boost 5	BP5	10kHz, LINE OUT 0dB, NR B, TAPE IN	-1.1	0	1.9	
NR C decode boost 1	CP1	500Hz, LINE OUT -60dB, NR C, TAPE IN	14.2	16.5	18.2	dB
NR C decode boost 2	CP2	500Hz, LINE OUT -25dB, NR C, TAPE IN	7.2	9.8	11.2	
NR C decode boost 3	CP3	2kHz, LINE OUT -60dB, NR C, TAPE IN	18.7	20.9	22.7	
NR C decode boost 4	CP4	2kHz, LINE OUT -25dB, NR C, TAPE IN	5.4	7.3	9.4	
NR C decode boost 5	CP5	5kHz, LINE OUT -25dB, NR C, TAPE IN	3.5	5.7	7.5	
NR C decode boost 6	CP6	10kHz, LINE OUT 0dB NR C, TAPEIN	-5.5	-3.9	-1.5	

Electrical Characteristics

Item	Symbol	Measurement conditions (input pin, input level frequency etc.)	Min.	Typ.	Max.	Unit
TAPE IN total harmonic distortion 1	THD1	TAPE IN -20dBm 1kHz R1=2.7k	—	0.01	0.2	%
TAPE IN total harmonic distortion 2	THD2	TAPE IN -20dBm 1kHz NR B R1=2.7k	—	0.04	0.2	
TAPE IN total harmonic distortion 3	THD3	TAPE IN -20dBm 1kHz NR C R1=2.7k	—	0.07	0.3	
Decode S/N ratio	SN1	No signal NR B CCIR/ARM filter	77.0	84.0	—	dB
	SN2	No signal NR C CCIR/ARM filter	80.0	82.0	—	
Signal handling	VSH1	TAPE IN 1kHz RL=2.7kΩ THD=1%	13.5	14.4	—	dB
Cross talk TAPE IN 1 ch → 2 ch	CT3	TAPE IN -24dBm 1kHz	—	-91	-55	
LINE OUT offset voltage	Vos1	No signal	3.9	4.0	4.1	V
B/C Switching noise	VBoTU	Level at PB IN to LINE OUT, LINE OUT	—	70	100	mV
Playback equalizer amplifier block						
120 μs FWD frequency response	PBREF	PB F IN 315Hz -70dBm VPBO=0dB	-27.0	-25.5	-23.0	dBm
	F120F	PB F IN 2.7 kHz -58.5 dBm for 315 Hz	-1.5	-0.8	1.5	dB
70 μs FWD frequency response	F70F	PB F IN 4.5 kHz -53.8 dBm for 315 Hz	-1.5	-0.0	1.5	dB
	F120R	PB R IN 315 Hz -70 dBm for 315 Hz	-1.0	-0.3	1.0	
Signal handling	VSH2	PB F IN 1kHz THD=1% RL=2.7kΩ	-10.0	-3.0	—	dBm
Total harmonic distortion	THD6	PB F IN 1kHz -52dBm RL=2.7kΩ	—	0.11	0.5	%
S/N ratio	SN3	No signal "A" weighting filter ON	57.0	61.1	—	dB
Output offset voltage	Vos2	No signal Rg=2.2 kΩ	1.55	1.95	2.35	V
Cross talk between channels	CT4	TAPE IN 1kHz -42dBm	—	-80.5	-70	dB
Cross talk between RVS and FWD	CT5		—	-77.7	-65	
Interval detection between tracks (MUSIC SENSOR) block						
Signal detection level 1	VMS1	TAPE IN 5 kHz AMS ON (G1 mode) External constant 10 kΩ, 0.015 μF	-43.0	-39.0	-35.0	dBm
Signal detection level 2	VMS2	TAPE IN 5 kHz AMS ON (G2 mode) External constant 1 kΩ, 1.5 μF	-62.5	-58.5	-54.5	
MS output leak current	IOH	TAPE IN 5 kHz -10 dBm, 5 V applied to AMSOUT	—	0.0	1.0	μA
MS output saturation voltage	VOL	TAPE IN 5 kHz -30 dBm, 1 mA applied to AMSOUT	—	0.3	1.0	V
Logic voltage						
2-value input	VIL	NRSW, TAPESW, DRSW, NRMODE, MSSW, MSMODE	0.0	—	0.8	V
	VIH		2.5	—	Vcc	
Boost charge circuit block						
PBFB boost charge current	ICRG	No signal, 3.4 V applied to VCT and 1.8 V to PBFB	1.0	3.0	—	mA
Boost charge ON VCT level	VCRG1	No signal, VCT level when boost charge ON	—	—	3.4	V
Boost charge OFF VCT level	VCRG2	No signal, VCT level when boost charge OFF	3.6	—	—	

Electrical Characteristics Measurement Circuit

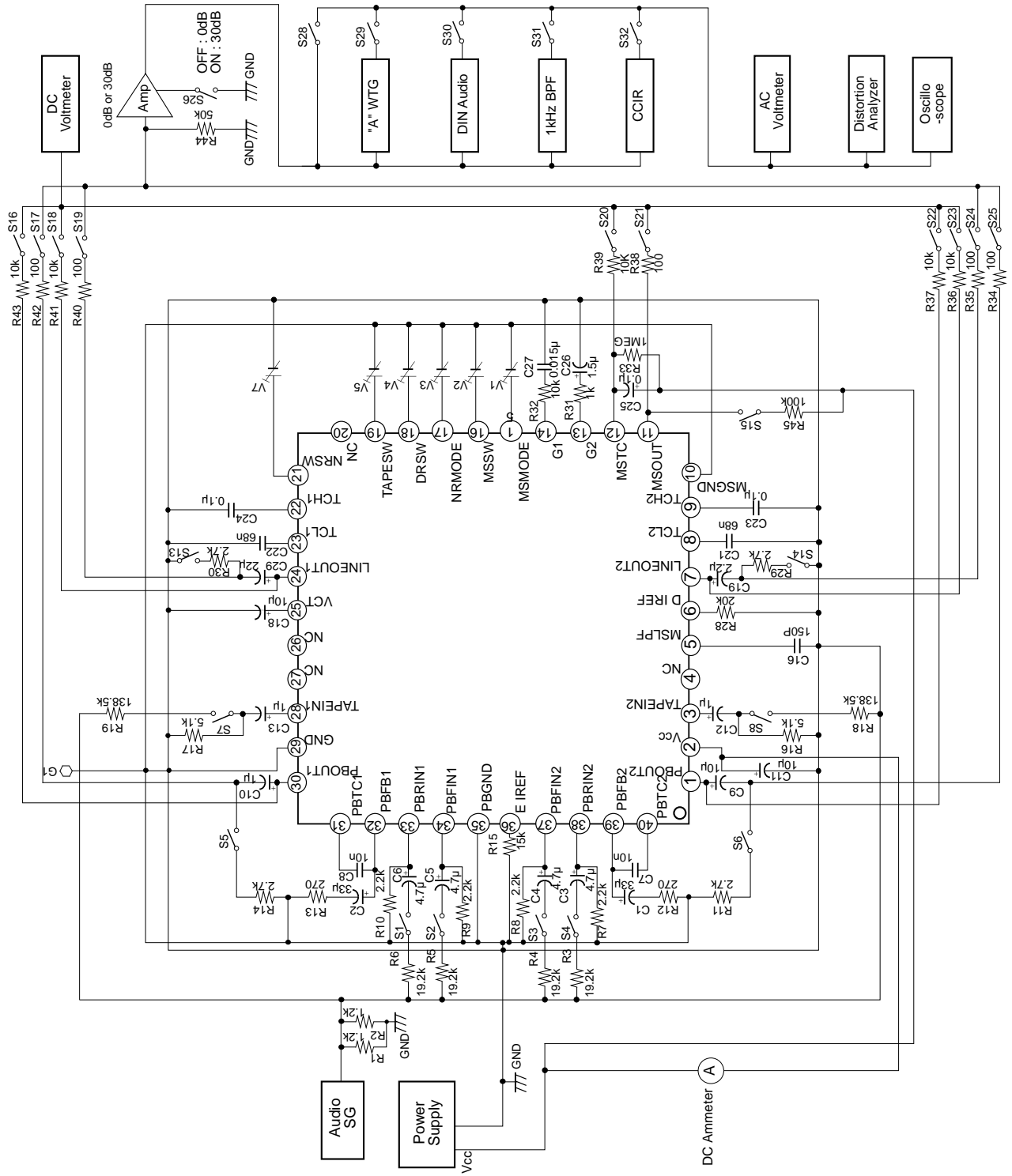

Operating modes (TAPESW, DRSW, NRSW, MSSW, MODESW, NRMODE)

The CXA1911Q has an NR switch (NRSW), NR mode switch (NRMODE), equalizer switch (TAPESW), head switch (DRSW), MS switch (MSSW), and MS gain switch (MSMODE).

The operating modes for each switch are shown in the following table.

SW	Function for Low input	Function for High input
NRSW	NR OFF	NR (B/C) ON
NRMODE	DOLBY B	DOLBY C
TAPESW	70 μ S	120 μ s
DRSW	PB FWD	PB RVS
MSSW	MS OFF	MS ON
MSMODE	G2 MODE	G1 MODE

Click noise can be reduced by the external CR time constant for NRSW switching.

Description of Operation

1. Signal route

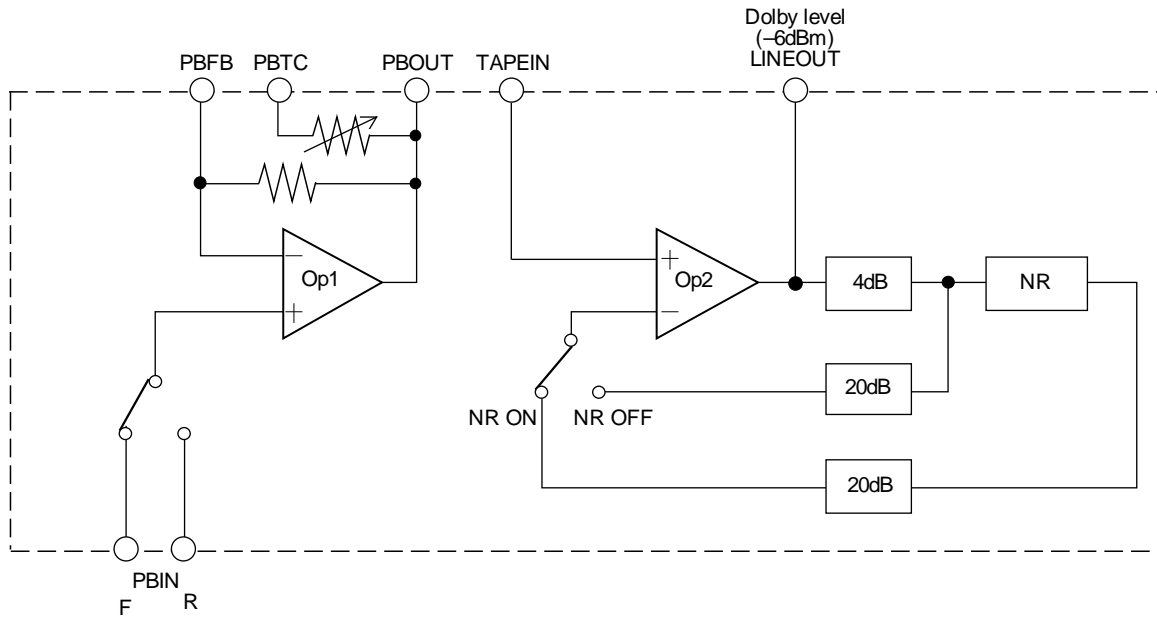

Fig. 1

Op1 and Op2 are operational amplifiers.

Op1 composes the playback equalizer by attaching a resistor and a capacitor to PBFB pin, and a capacitor to PBTC pin.

Op2 is an input selector and a LINEOUT amplifier. The gain is 24 dB.

The Dolby reference level is -6 dBm (LINEOUT).

The adjustment method of playback equalizer is described in the paragraph (3).

- Note) Usually the TAPEIN pin level is adjusted by attenuator connected to PBOUT pin.
 The capacitance value connected to PBFB can be reduced by adjusting the resistance connected to PBFB to match the PBOUT level.
 With this method, the capacitance value can be reduced according to the amount that the resistance value is increased even for the same cut-off frequency.
 (These specifications use the latter method.)

2. Level diagram

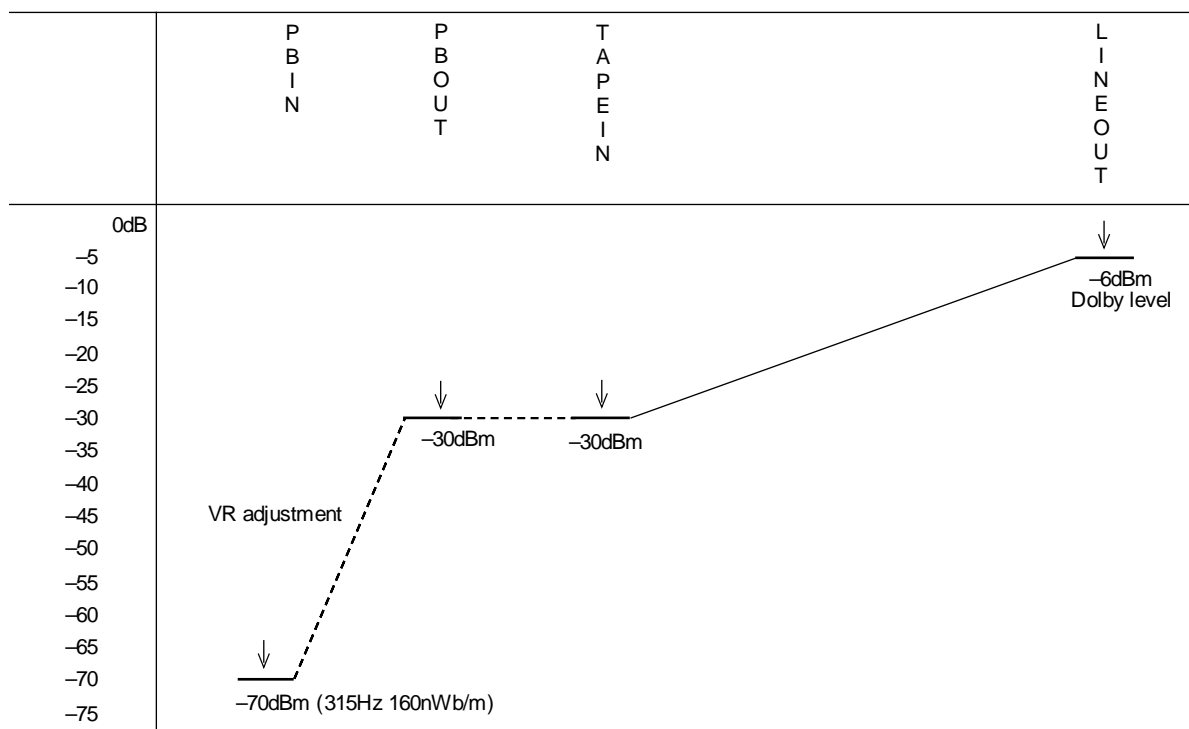
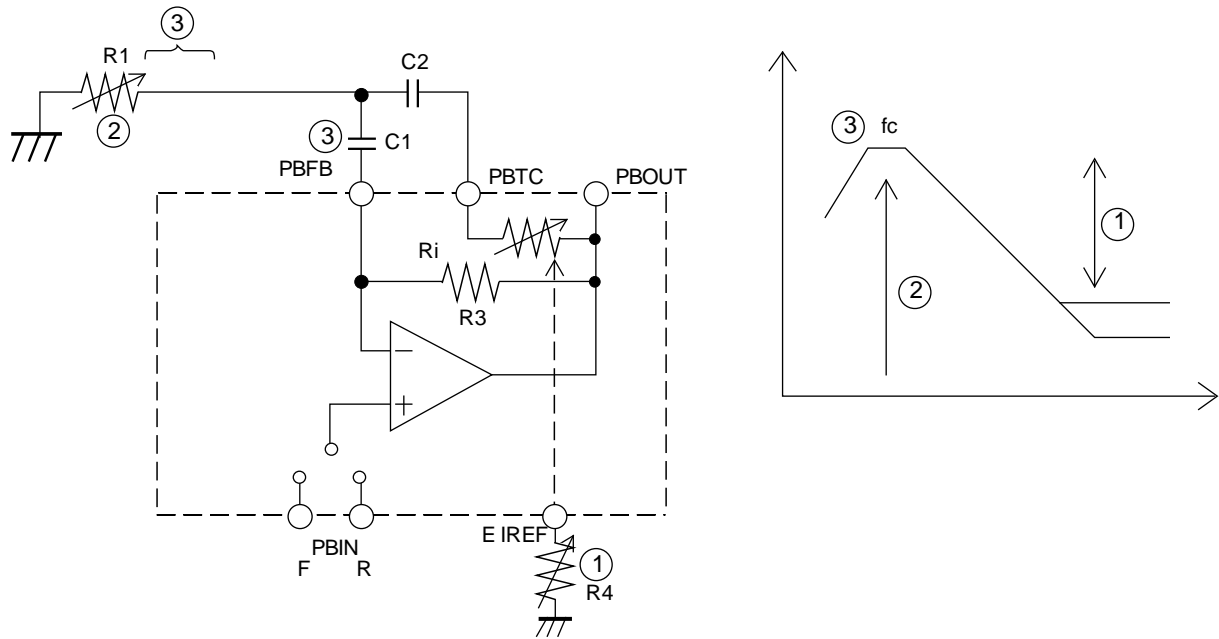

Fig.2

Note) This diagram illustrates the case where the Dolby level is aligned by adjusting the resistance value connected to PBF B.

3. PBEQ adjustment



1) EQ curve gain difference (=adjustment of internal variable R) → IREF resistor
 To adjust the EQ curve gain differences ($G1 - G2$, $G1 - G3$), the E IREF resistor should be adjusted to change the internal variable resistance value.

2) AC gain → External resistor R1
 The external resistor R1 should be adjusted to adjust the AC gain.
 $G1$ is obtained by the following equation.

$$G1 = 20 \log \frac{R1 + R3}{R1} \quad (R3 = 300k\Omega)$$

3) Low-band cut-off frequency → External resistor R1 and capacitor C1
 The low-band cut-off frequency (f_c) can be determined by the external resistor R1 and external capacitor C1.

Note) In this diagram, C1 and R1 are not connected in series, but are connected to PBFB from between R1 and C2.

This is to prevent the sound quality from deteriorating when using an electrolytic capacitor.

4. MS (internal detection between tracks) adjustment method

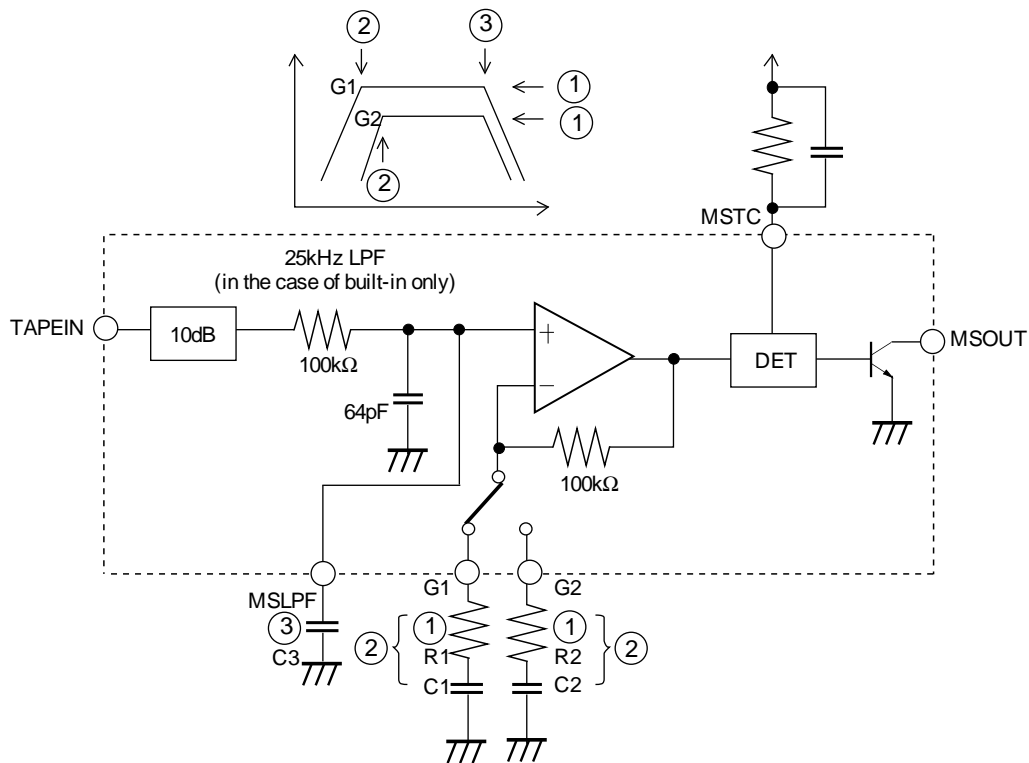

- 1) MS gain (FF/NOR mode gain) adjustment → External resistors R1 and R2
 MS gain is expressed by the following equations.

$$G1 = 10 + 20\log \frac{R1 + 100k}{R1} \text{ [dB]} \qquad G2 = 10 + 20\log \frac{R2 + 100k}{R2} \text{ [dB]}$$

- 2) MS low-band cut-off frequency adjustment → External resistors R1 and R2 and external capacitors C1 and C2

The external resistors R1 and R2 and external capacitors C1 and C2 should be adjusted to adjust the low-band cut-off frequency for the MS frequency response.

- 3) MS high-band cut-off frequency adjustment → External capacitor C3

The external capacitor C3 should be adjusted to adjust the high-band cut-off frequency for the MS frequency response. (In this case, G1 and G2 have the same cut-off frequency.)

Characteristics Graphs

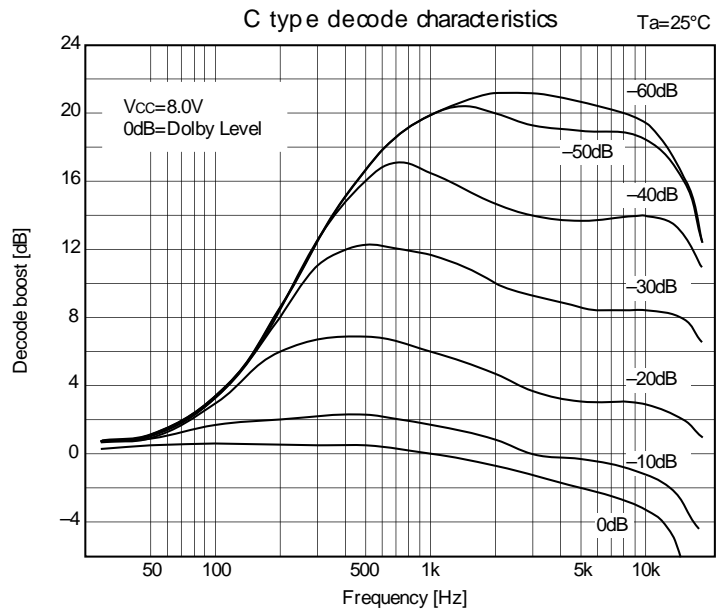
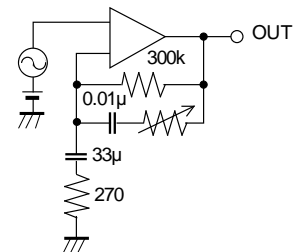
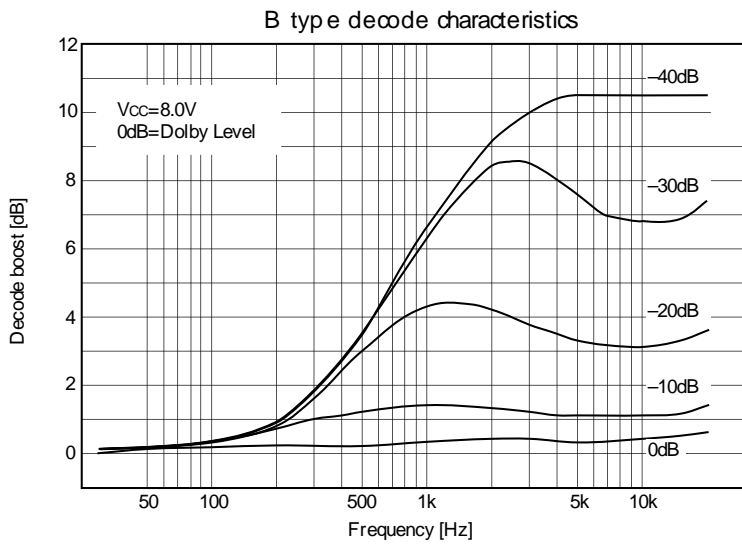
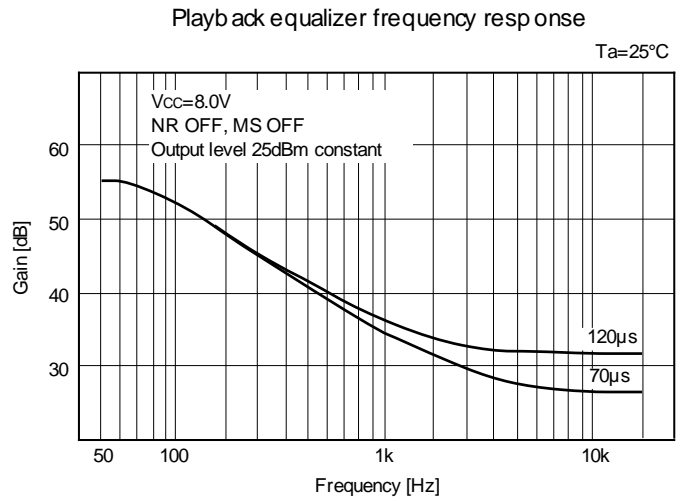
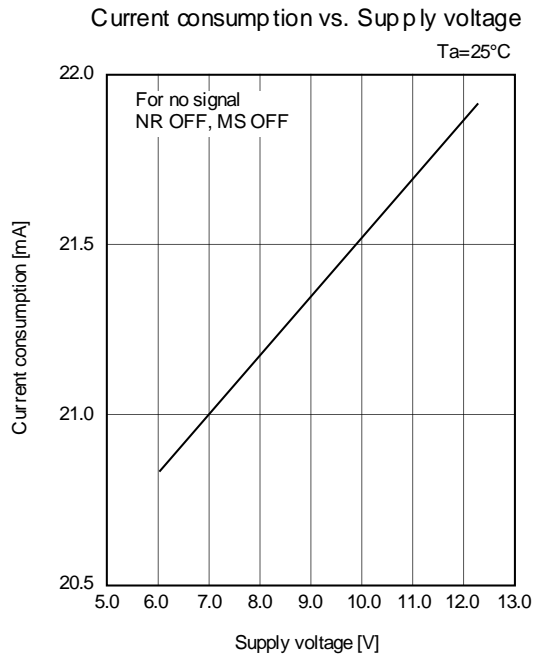

Total harmonic distortion (pre-amplifier block)

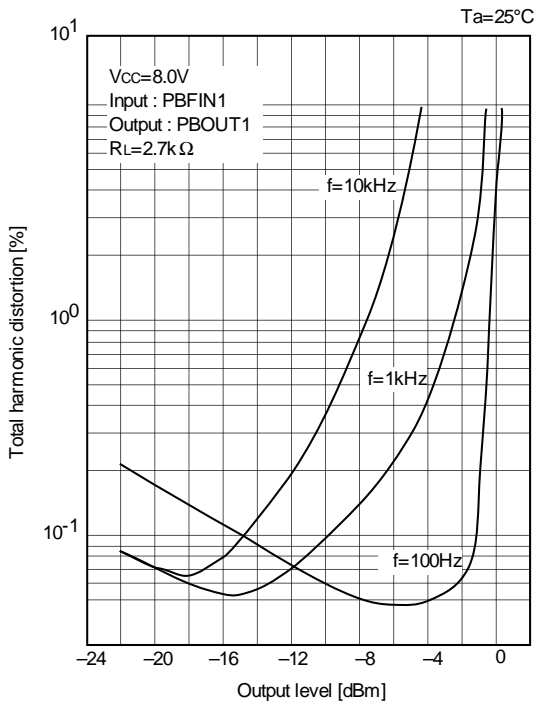

B type total harmonic distortion

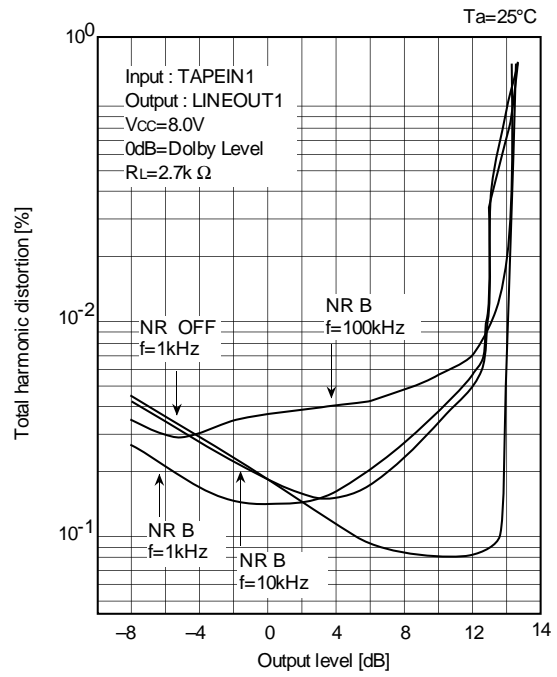

C type total harmonic distortion

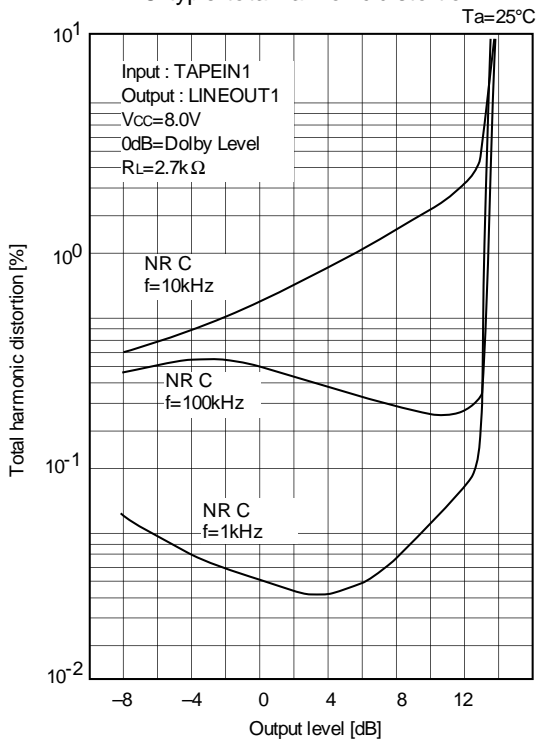

Ripple rejection ratio (PBOUT)

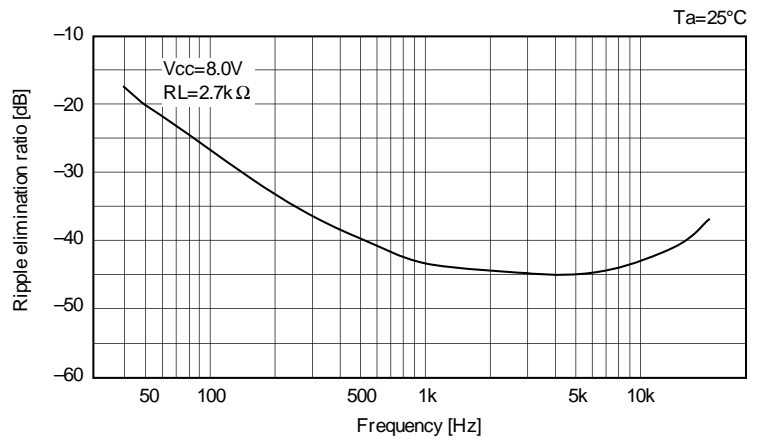

Rippler rejection ratio (LINEOUT)

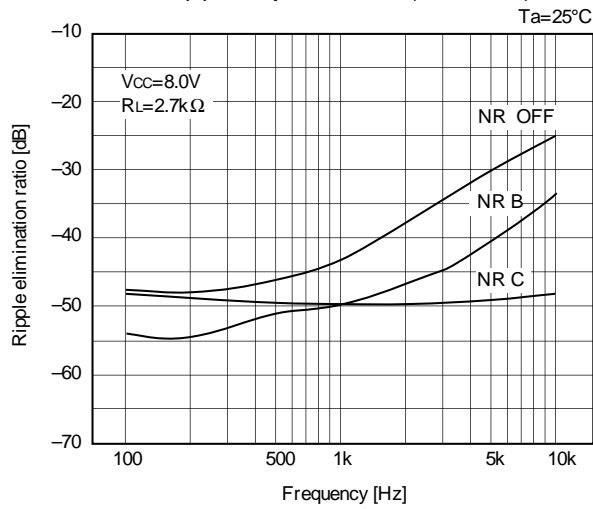

Cross talk between channels (1ch → 2ch)

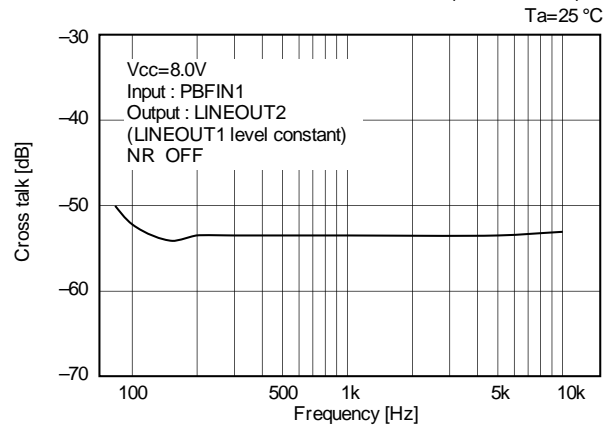

Blank detection level frequency response

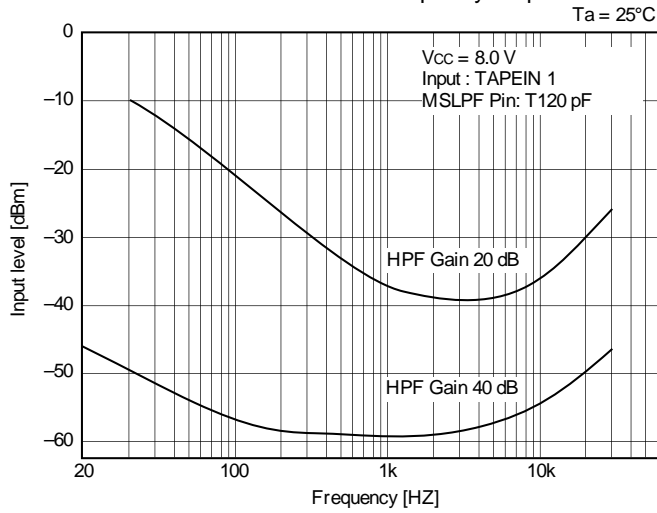

MS block gain vs. Blank detection level

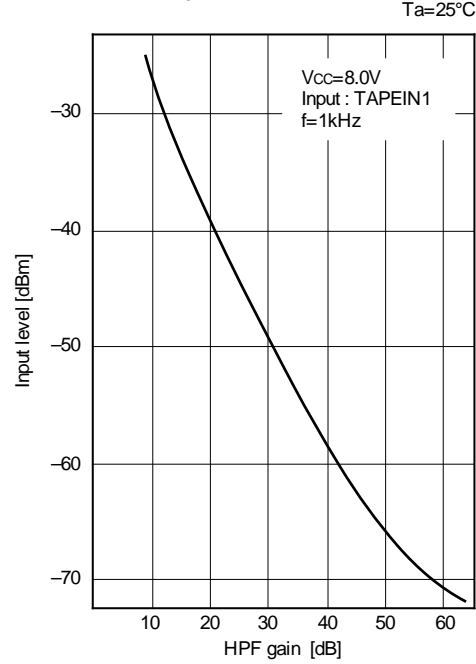

Package Outline Unit : mm

40PIN QFP (PLASTIC)

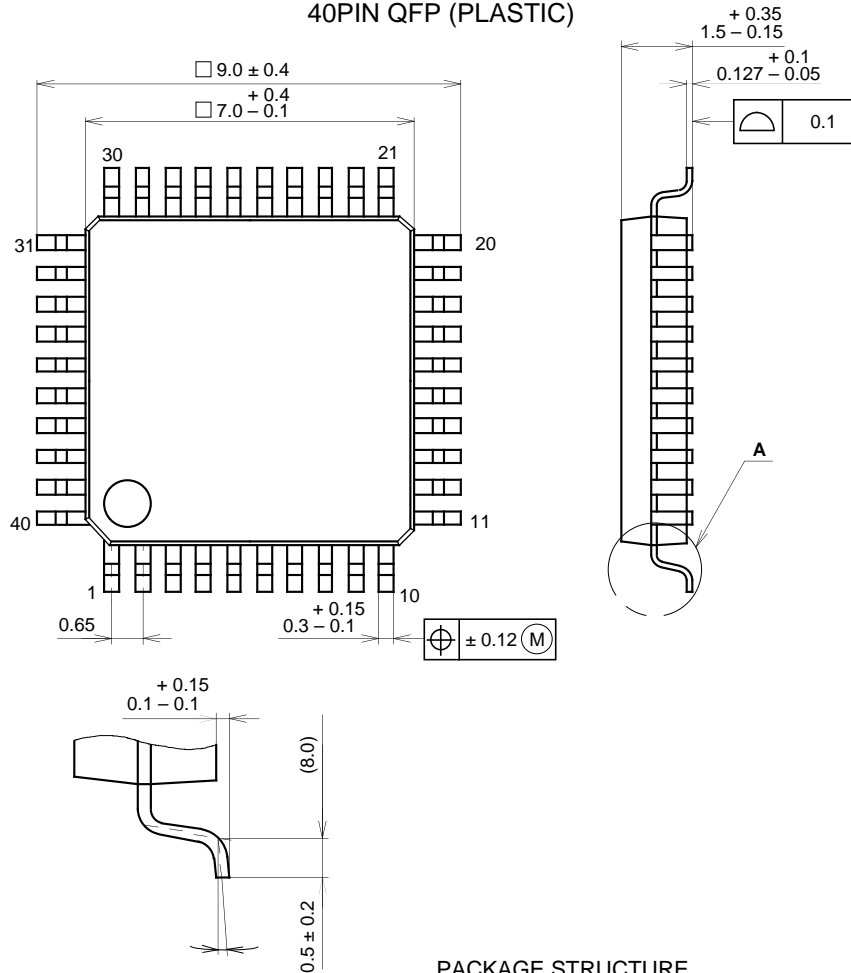

PACKAGE STRUCTURE

PACKAGE MATERIAL	EPOXY RESIN
LEAD TREATMENT	SOLDER / PALLADIUM PLATING
LEAD MATERIAL	COPPER / 42 ALLOY
PACKAGE WEIGHT	0.2g

SONY CODE	QFP-40P-L01
EIAJ CODE	*QFP040-P-0707
JEDEC CODE	_____

This datasheet has been downloaded from:

www.DatasheetCatalog.com

Datasheets for electronic components.



LittleDiode supplies new, hard to find or obsolete electronic components and semiconductors all over the world.

With over two million different components listed you are sure to find the part you need.

Feel free to visit us today at our online store:

LittleDiode.com

Looking forward to providing you with the best possible service.