

**DD Dolby B Type Noise Reduction System with Playback Equalizer**

**Description**

The CXA1910Q is an IC designed for use in car stereos. Functions include Dolby B type noise reduction, playback equalizer amplifier and Music sensor into a single chip.

**Features**

- Few external parts
- Forward/Reverse head switching
- Small package (40-pin QFP)
- Dolby B type noise reduction and playback equalizer into a single chip
- Same pin configuration as Dolby B/C type noise reduction system (CXA1911)
- Music sense level can be set by external resistors/capacitors (2 modes).
- High-band cut filter frequency can be adjusted by the external capacitance.

**Applications**

- Car stereos
- Stereo cassette deck players (playback only)

**Structure**

Bipolar silicon monolithic IC

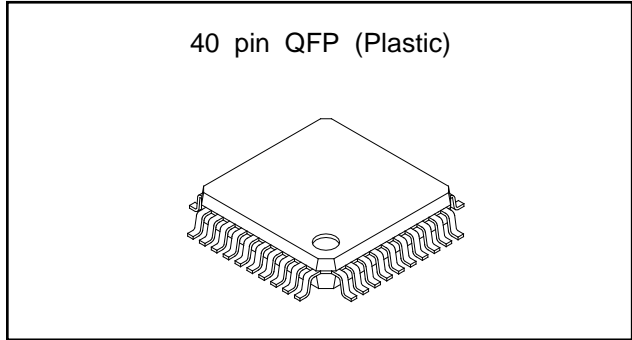

**Absolute Maximum Ratings (Ta=25°C)**

• Supply voltage	VCC	12	V
• Operating temperature	Topr	-40 to +85	°C
• Storage temperature	Tstg	-65 to +150	°C
• Allowable power dissipation	PD	430	mW

**Recommended Operating Condition**

Supply voltage	VCC	6.5 to 11	V
----------------	-----	-----------	---

\* These ICs are available only to the licensees of Dolby Laboratories Licensing Corporation from whom licensing and applications information may be obtained.  
 \* "Dolby" and the double D symbols are trade marks of Dolby Laboratories Licensing Corporation.  
 \* Sony reserves the right to change products and specifications without prior notice. This information does not convey any license by any implication or otherwise under any patents or other right. Application circuits shown, if any, are typical examples illustrating the operation of the devices. Sony cannot assume responsibility for any problems arising out of the use of these circuits.

Block Diagram and Pin Configuration

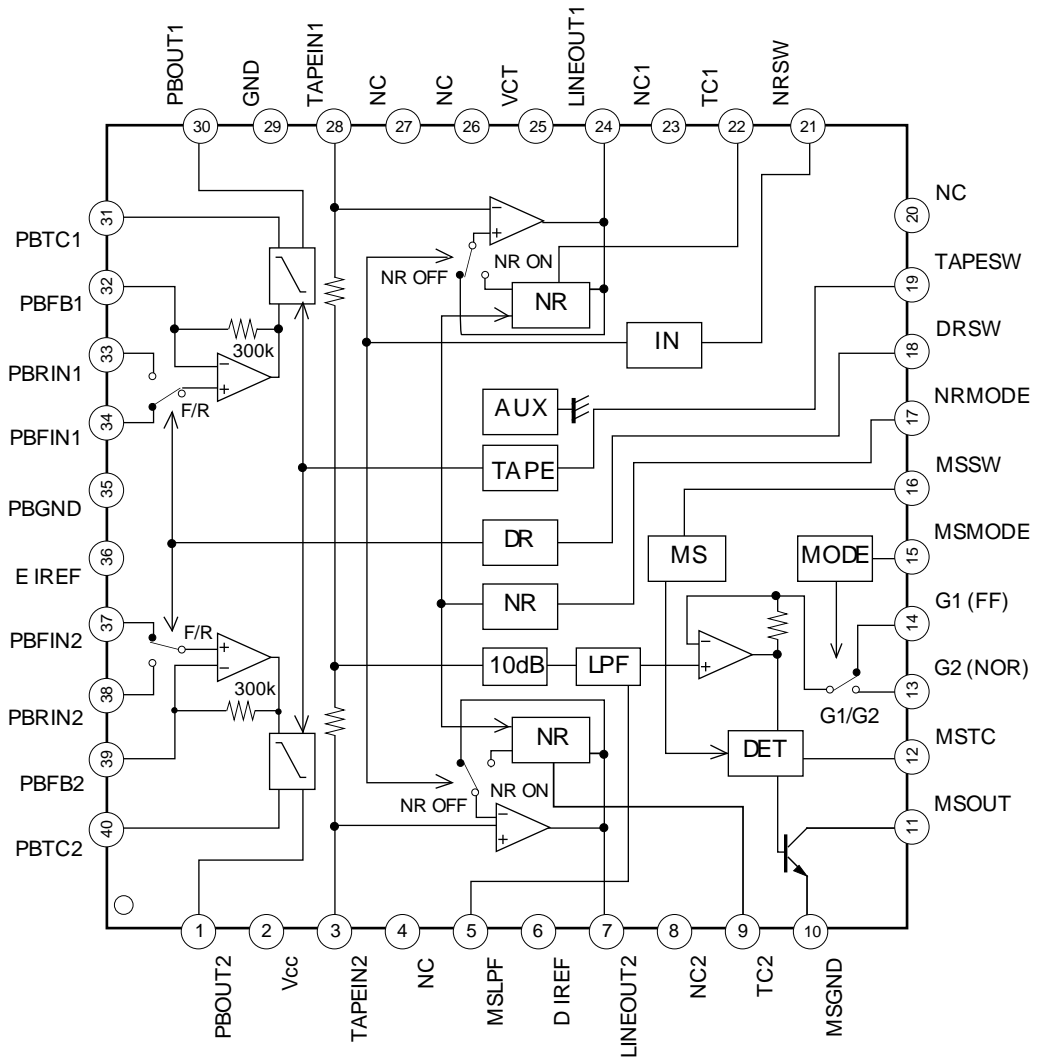

Pin Description

(Ta=25°C, Vcc=8.0V, no signal)

Pin No.	Symbol	DC value	Z (in)	Equivalent circuit	Description
1 30	PBOUT	2.1V	—	Refer to Page 6.	PBEQ output
32 39	PBFB	2.1V	300kΩ		PBEQ feedback
33 34 37 38	PBIN	0V	—		PBEQ input
2	Vcc	8.0V	—		Power supply
10 29 35	MSGND GND PBGND	0.0V	—		Ground
31 40	PBTC	—	—		PBEQ capacitance
36	E IREF	1.25V	—		Reference current setting resistor pin
11	MSOUT	0.0V for signal detection; 5.0V for no signal detection	—		MS output

Pin No.	Symbol	DC value	Z (in)	Equivalent circuit	Description
12	MSTC	Approx. 1.4V for signal detection; 5.0V for no signal detection	—		Connection of MS detection time constant
13 14	G2(NOR) G1(FF)	4.0V	—		MS feedback
3 28	TAPEIN	4.0V	40k		TAPE input
6	D IREF	1.25V	—		Connection of reference current setting resistor for Dolby block
7 24	LINEOUT	4.0V	—		Line output

Pin No.	Symbol	DC value	Z (in)	Equivalent circuit	Description
9 22	TC	0.3V	—		Time Constant pin for the level detector
15 17 18 19 21	MSMODE NRMODE DRSW TAPESW NRSW	—	—		Refer to Page 6.
16	MSSW	—	—		Refer to Page 6.
25	VCT	4.0V	—		Vcc/2 output
4 8 20 23 26 27	NC	—	—		No connection.
5	MSLPF	4.0V	100k		Capacitance connection for adjusting the MS LPF time constant.

\* PBOUT, PBFB, PBIN equivalent circuit

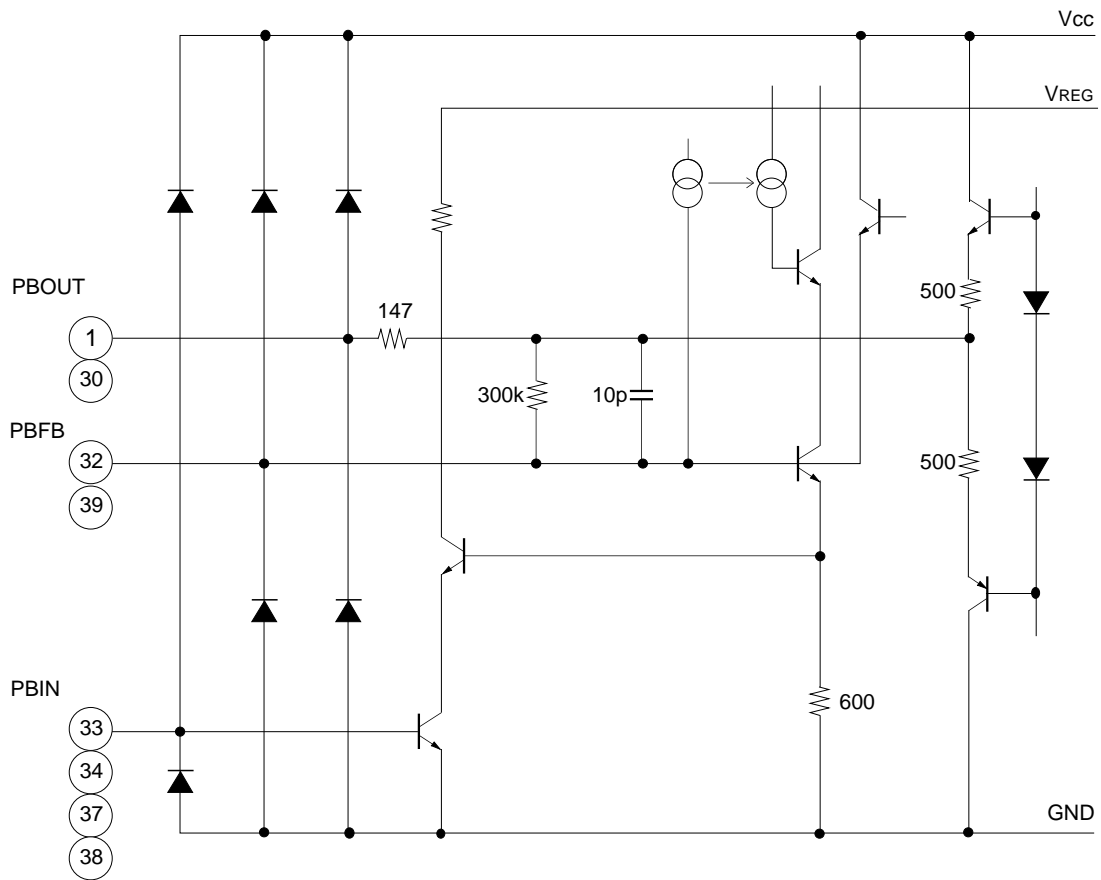

\* Description for SW pins

MSMODE - Switching of MS signal detection/blank detection

High: G1; Low: G2

NRSW - Switching of Dolby B type noise reduction ON/OFF

High: noise reduction ON; Low: noise reduction OFF

DRSW - Switching of tape direction

High: reverse; Low: forward

TAPESW - Switching of HIGH/NORMAL tape

High: NORMAL tape; Low: HIGH tape

NRMODE - Switching of noise reduction modes

High: noise reduction OFF; Low: Dolby B

MSSW - Switching of MS ON/OFF

High: MS ON; Low: MS OFF

## Electrical Characteristics

(Ta=25°C, Vcc=8.0V, RL: output load resistance, Rg: head equivalent impedance)

Item	Symbol	Measurement conditions* (input pin, input level, frequency etc.)	Min.	Typ.	Max.	Unit
Current consumption	Icc	No signal	14.5	17.9	21.5	mA
Dolby block (Dolby level -6dBm=0dB)						
TAPE IN input sensitivity	VTIN	LINEOUT= 0 dB 1kHz	-32.0	-30.0	-28.0	dBm
Decode boost 1	BP1	TAPE IN 500Hz NR-ON Vlo=-25dB	1.4	2.9	4.4	dB
Decode boost 2	BP2	TAPE IN 2kHz NR-ON Vlo=-25dB	5.5	6.4	8.5	
Decode boost 3	BP3	TAPE IN 5kHz NR-ON Vlo=-25dB	3.9	5.2	6.9	
Decode boost 4	BP4	TAPE IN 10kHz NR-ON Vlo=-40dB	9.7	10.4	11.9	
Decode boost 5	BP5	TAPE IN 10kHz NR-ON Vlo=0dB	-1.1	0.4	1.9	
TAPE IN total harmonic distortion 1	THD1	TAPE IN -20dBm 1kHz RL=2.7kΩ	—	0.03	0.2	%
TAPE IN total harmonic distortion 2	THD2	TAPE IN -20dBm 1kHz NR-ON RL=2.7kΩ	—	0.04	0.2	
Decode S/N ratio	SN1	No signal NR-ON CCIR/ARM filter	77.0	82.8	—	dB
Signal handling	VOMAX1	1kHz THD=1% RL=2.7kΩ	13.0	14.4	—	dB
Cross talk TAPE 1ch→2ch	CT3	TAPE IN -24dBm 1kHz	—	-67	-55	
LINEOUT offset voltage	Vos1	No signal	3.9	4.0	4.1	V
Playback equalizer amplifier block						
120μs FWD frequency characteristics	PBREF	PB F IN 315Hz -70dBm VPBO=0dB	-27.0	-25.0	-23.0	dBm
120μs FWD frequency characteristics	F120F	PB F IN 2.7kHz -58.5dBm for 315Hz	-1.5	0.7	1.5	dB
70μs FWD frequency characteristics	F70F	PB F IN 4.5kHz -53.8dBm for 315Hz	-1.5	0.0	1.5	
120μs RVS frequency characteristics	F120R	PB R IN 315Hz -70dBm for 315Hz	-1.0	0.0	1.0	
Signal handling	VOMAX2	PB F IN 1kHz THD=1% RL=2.7kΩ	-10.0	-3.0	—	dBm
Total harmonic distortion	THD5	PB F IN 1kHz -52dBm RL=2.7kΩ	—	0.07	0.5	%
S/N ratio	SN2	No signal "A" weighting filter	57.0	60.0	—	dB
Output offset voltage	Vos2	No signal Rg=2.2kΩ	1.55	1.95	2.35	V
Cross talk between channels	CT4	PB IN 1kHz -42dBm	—	-78	-70	dB
Cross talk between RVS and FWD	CT5		—	-75	-65	
Interval detection between tracks (MUSIC SENSOR) block						
Signal detection level 1	VMS1	TAPE IN 5kHz MS-ON G1 (10kΩ, 0.015μF)	-43.0	-39.0	-35.0	dBm
Signal detection level 2	VMS2	TAPE IN 5kHz MS-ON G2 (1kΩ, 1.5μF)	-62.5	-58.5	-54.5	
MS output leak current	IoH		—	0.0	1.0	μA
MS output saturation voltage	VOL	TAPE IN 5kHz -30dBm, 1mA applied to MSOUT AMS ON (G1 mode)	—	0.28	1.0	V
Boost charge circuit block						
PBFB boost-charge current	ICRG	No signal, 3.4V applied to VCT and 1.8V to PBFB	1.0	3.0	—	mA
Boost charge ON VCT level	VCRG1	No signal, VCT level when boost charge ON	—	—	3.4	V
Boost charge OFF VCT level	VCRG2	No signal, VCT level when boost charge OFF	3.6	—	—	
Logic voltage	VIL	MSMODE, NRMODE, MSSW,	0.0	—	0.8	
	VIH	TAPESW, NRSW, DRSW	2.5	—	Vcc	

\*120μs, FWD mode, NR OFF, MS OFF unless otherwise specified.

**Electrical Characteristics  
Measurement Circuit**

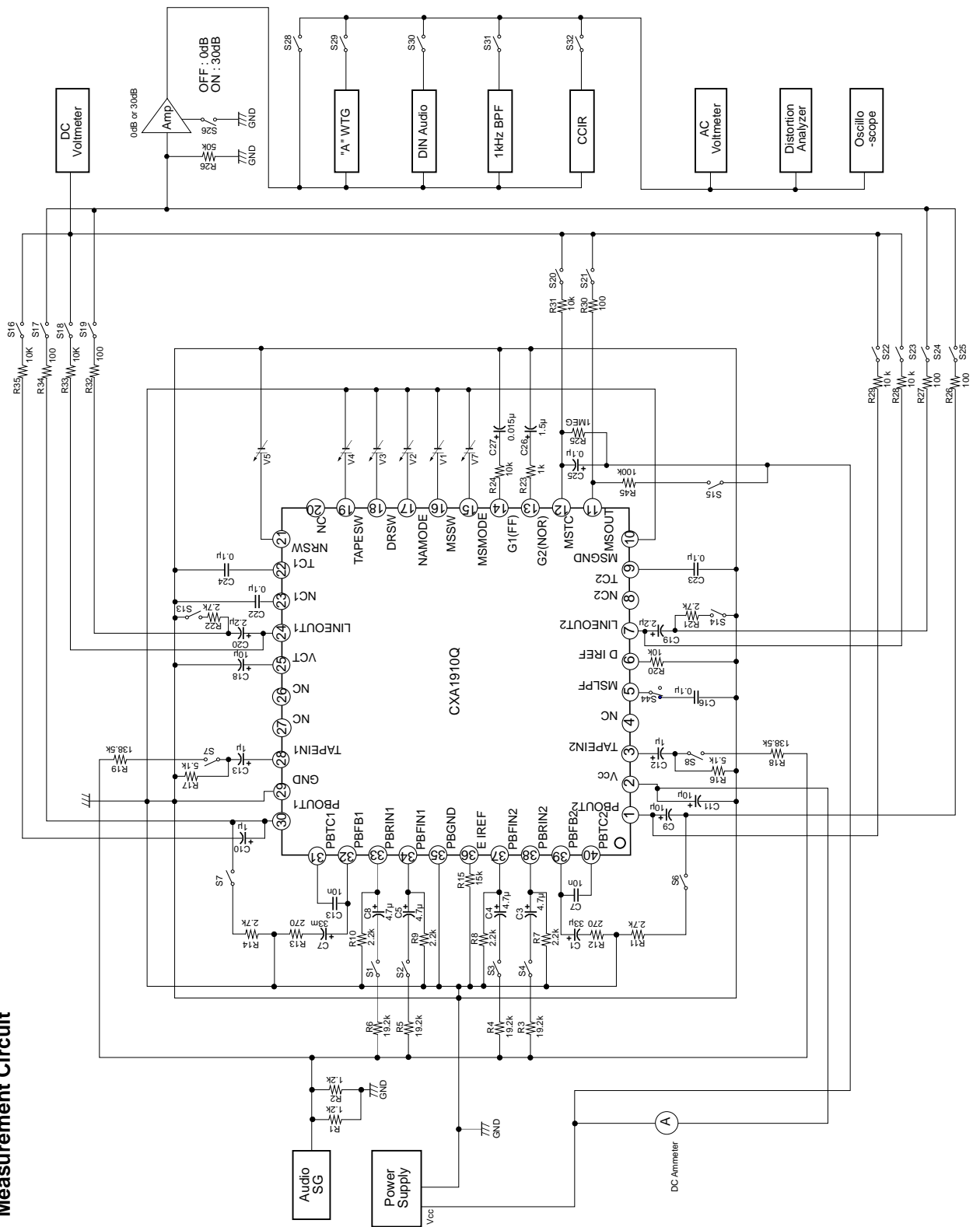



Application Circuit

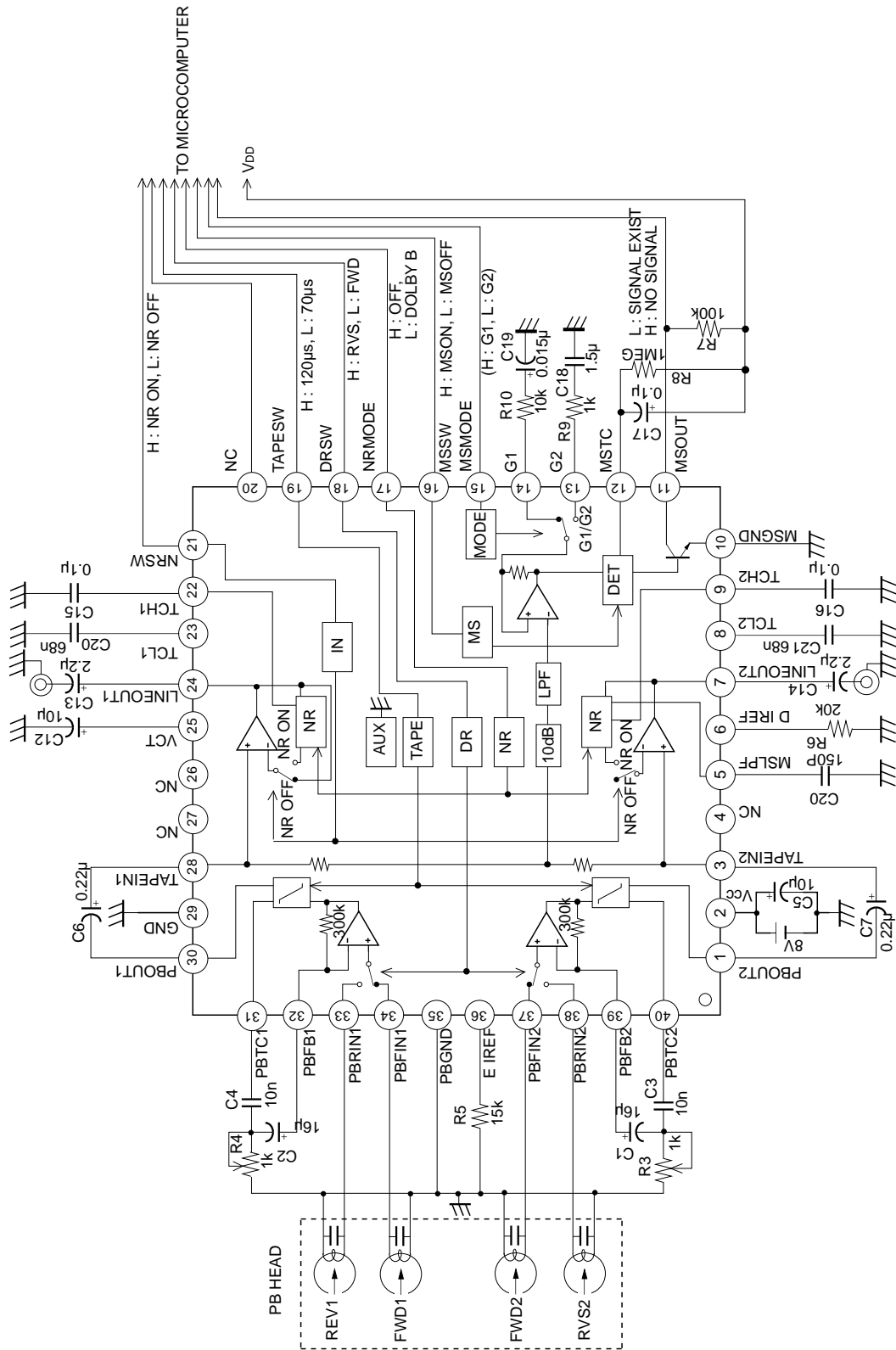

Application circuits shown are typical examples illustrating the operation of the devices. Sony cannot assume responsibility for any problems arising out of the use of these circuits or for any infringement of third party and other right due to same.

Operation mode control (INSW, AUXSW, TAPESW, DRSW, NRSW, MSSW, MODESW)

The CXA1910Q has built in electronic switch circuits and the operations are controlled by the direct current applied to each SW pin. The operation mode state for each switch is shown in the table below.

SW	Function for Low input	Function for High input
NRSW	NR OFF	NR ON
TAPESW	70 $\mu$ s	120 $\mu$ s
DRSW	PB FWD	PB RVS
NRMODE	DOLBY B	NR OFF
MSSW	MS OFF	MS ON
MSMODE	G2 (NOR) MODE	G1 (FF) MODE

Click noise can be reduced by the external CR time constant circuit for NR SW switching.

**Description of Operation**

(1) Signal route

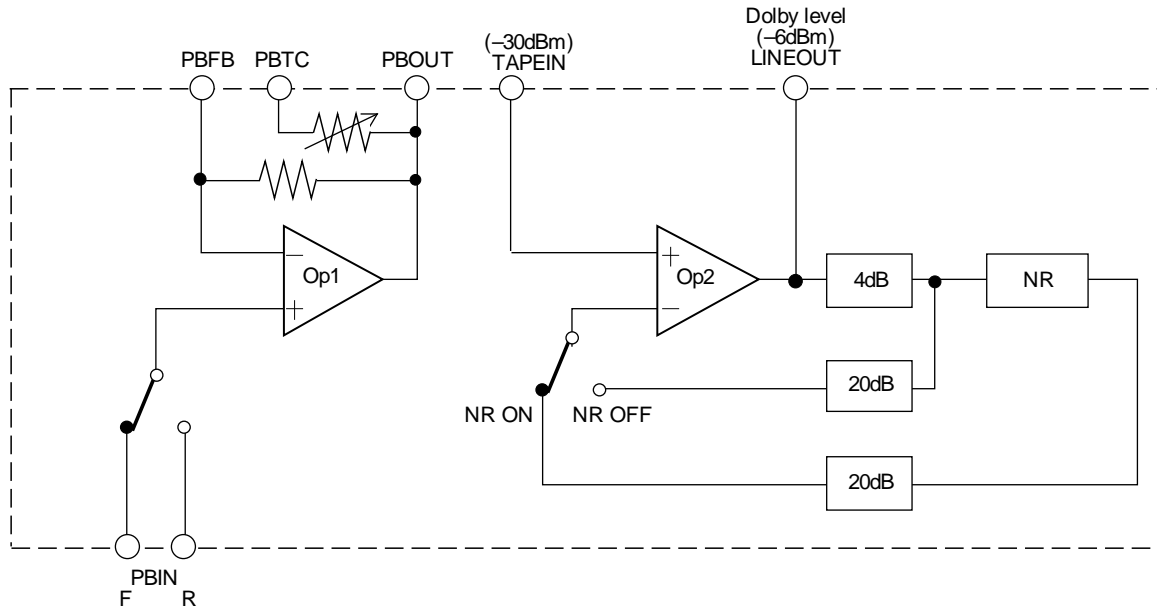

Fig. 1

Op1 and Op2 are operational amplifiers.

Op1 compose the playback equalizer by attaching a resistor and a capacitor to PBFB pin, and a capacitor to PBTC pin.

Op2 is an input selector and a LINEOUT amplifier. The gain of LINEOUT amplifier is 24dB.

Reference input level for Dolby is -30dBm.

The adjustment method of playback equalizer is described in the paragraph (3).

(2) Level diagram

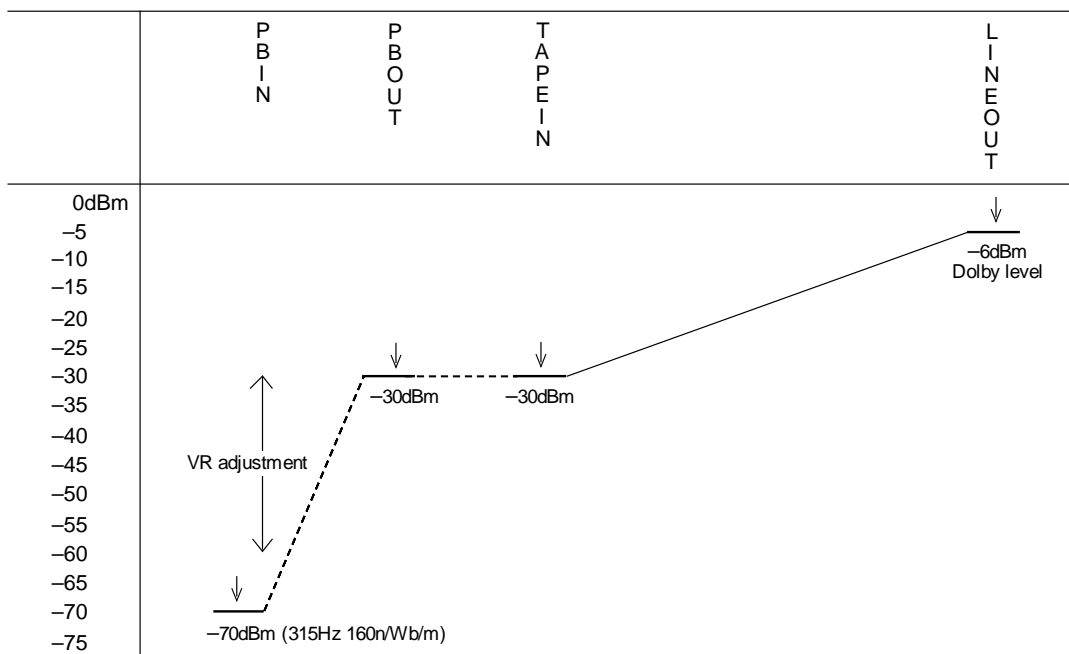

Fig. 2

(3) Adjustment of playback equalizer

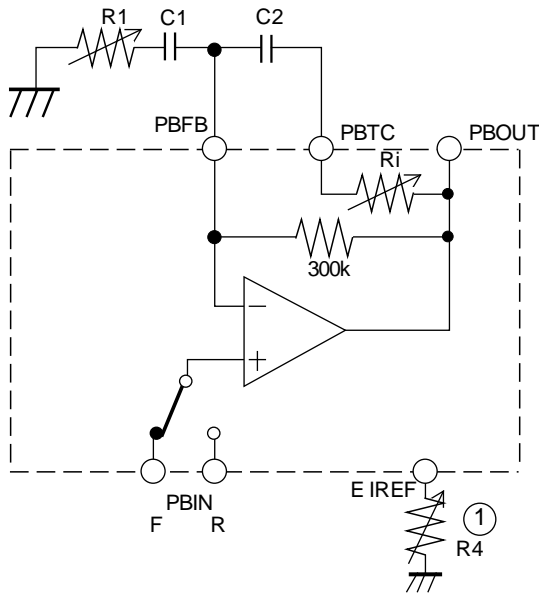

Fig. 3

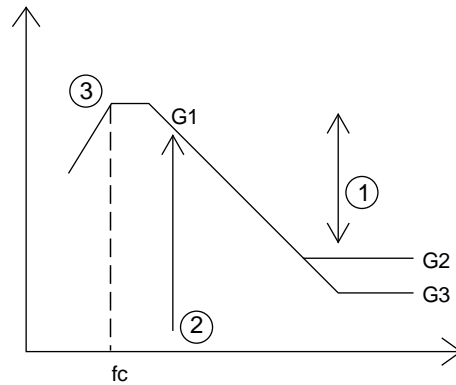

Fig. 4

- 1) Adjustment of EQ curve gain difference (= adjustment of internal variable R) → E IREF resistor  
The internal variable resistor Ri should be adjusted to adjust the EQ curve gain differences (G1-G2), (G1-G3). Therefore, adjust the external resistor R4 for E IREF pin.
- 2) AC gain adjustment → External resistor R1  
The external resistor R1 should be adjusted to adjust the AC gain. G3 are obtained by the following equations.

$$G1=10+20\log \frac{R1+300k}{R1} \text{ (dB)}$$

[AC gain can be also adjusted by attaching VR to PBOUT pin, fixing R1. However, the low-band cut-off frequency can be more lowered by R1 adjustment method with the same C1 value used for this method.]

- 3) Low-band cut-off frequency → External resistor R1 and external capacitor C1

The low-band cut-off frequency (fc) can be determined by the external resistor R1 and external capacitor C1.

(4) MS (internal detection between tracks) adjustment method

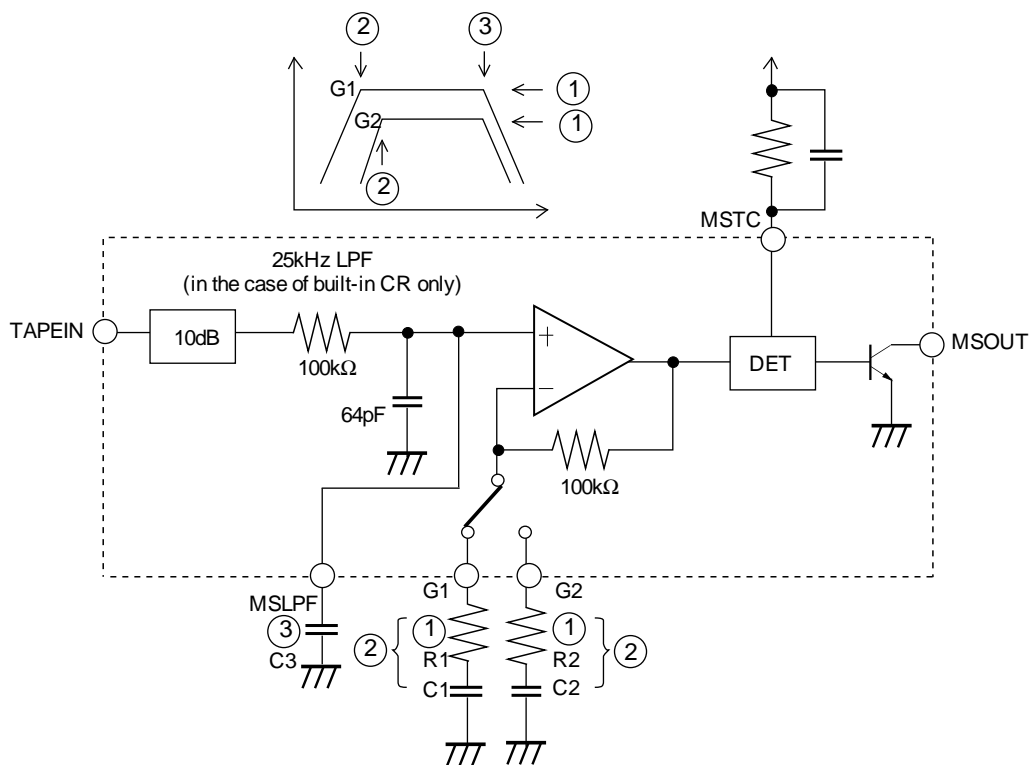

Fig. 5

- 1) MS gain (FF/NOR mode gain) adjustment → External resistors R1 and R2  
 MS gain is expressed by the following equations.

$$G1 = 10 + 20\log \frac{R1 + 100k}{R1} \text{ [dB]} \qquad G2 = 10 + 20\log \frac{R2 + 100k}{R2} \text{ [dB]}$$

- 2) MS low-band cut-off frequency adjustment → External resistors R1 and R2 and external capacitors C1 and C2

The external resistors R1 and R2 and external capacitors C1 and C2 should be adjusted to adjust the low-band cut-off frequency for the MS frequency response.

- 3) MS high-band cut-off frequency adjustment → External capacitor C3

The external capacitor C3 should be adjusted to adjust the high-band cut-off frequency for the MS frequency response. (In this case, G1 and G2 have the same cut-off frequency.)

Characteristics Graphs

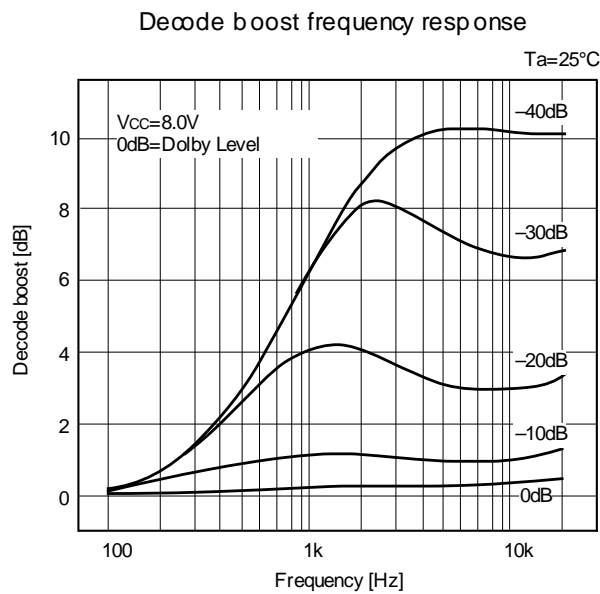
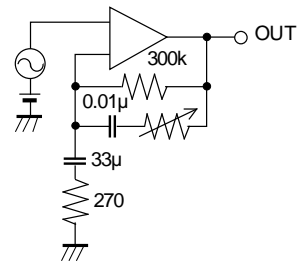
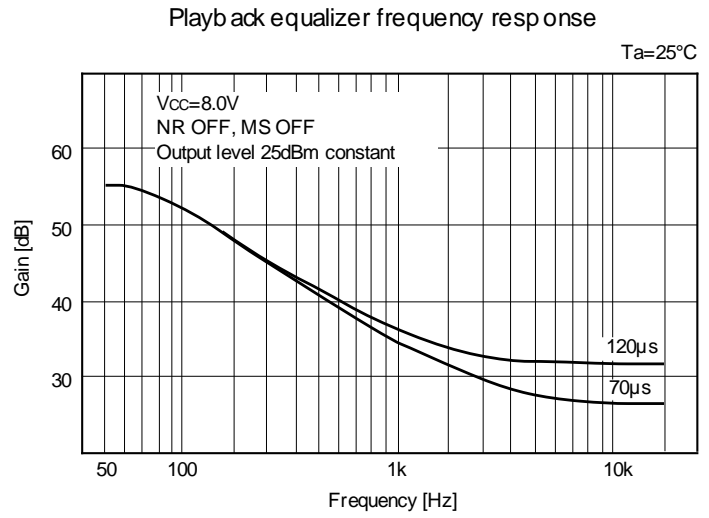
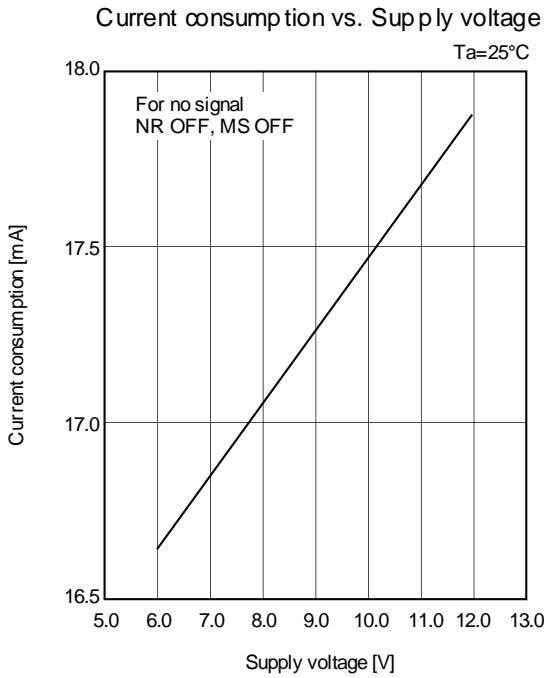

Total harmonic distortion (p re-amplifier block)

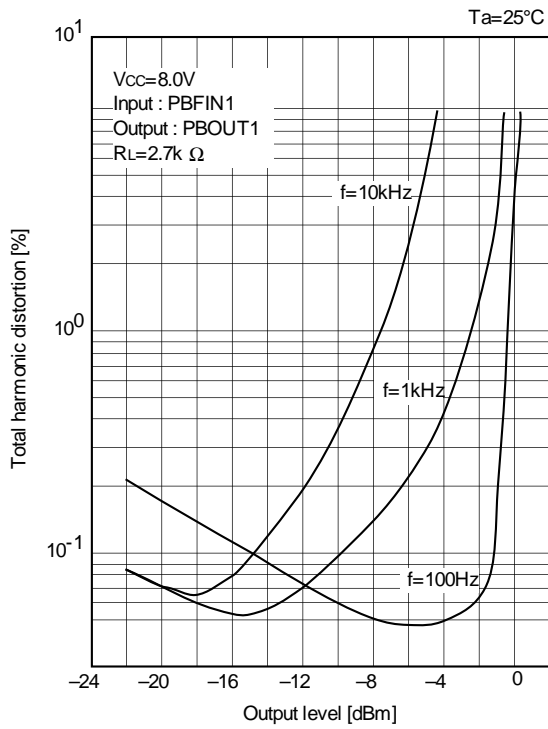

B type total harmonic distortion (Dolby block)

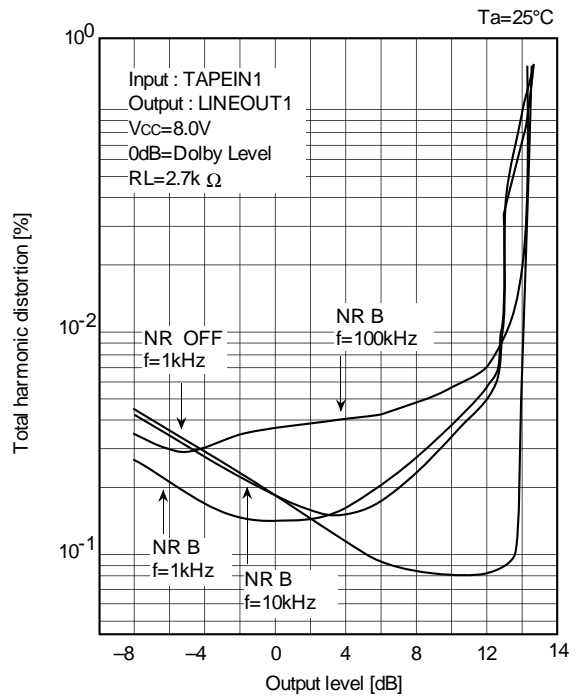

Ripple rejection ratio (PBOUT)

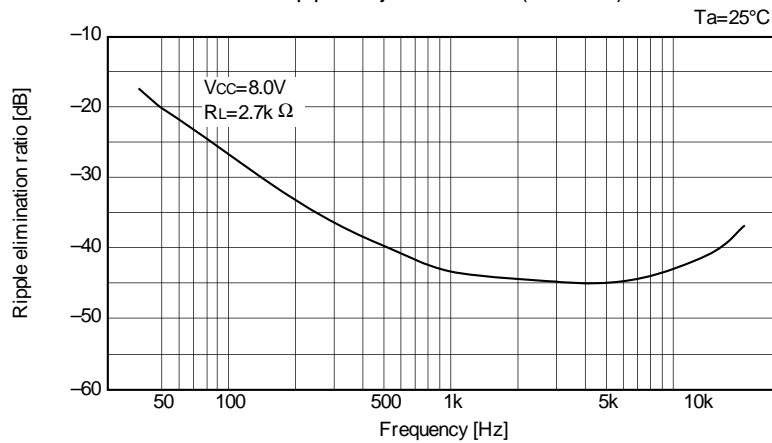

Ripple rejection ratio (LINEOUT)

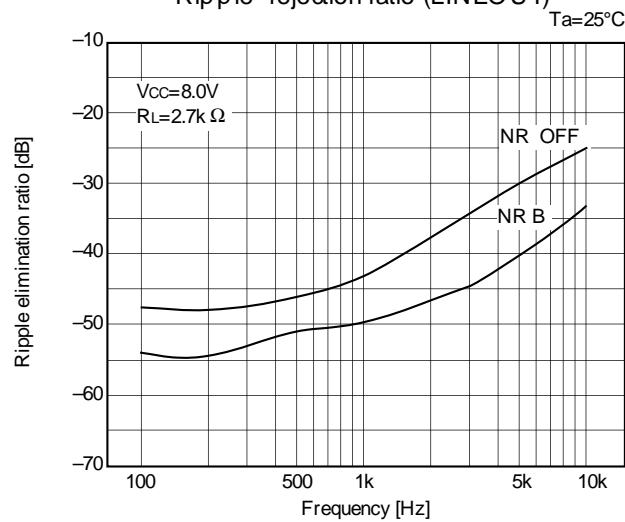

Cross talk between channels (1ch → 2ch)

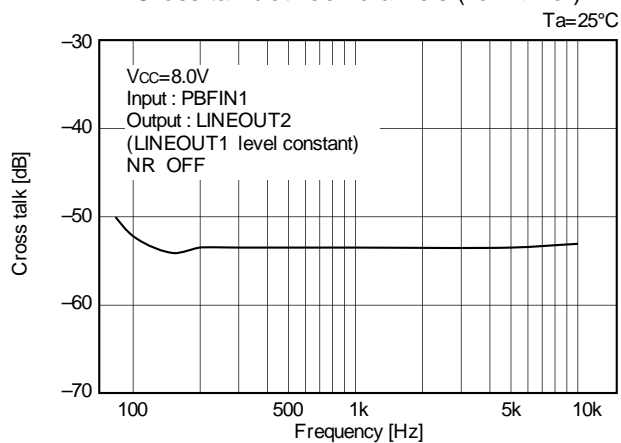

Blank detection level frequency response

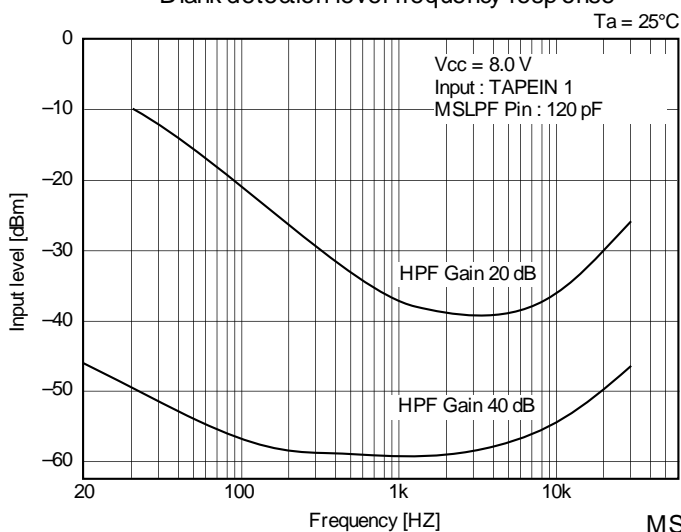

MS block gain vs. Blank detection level

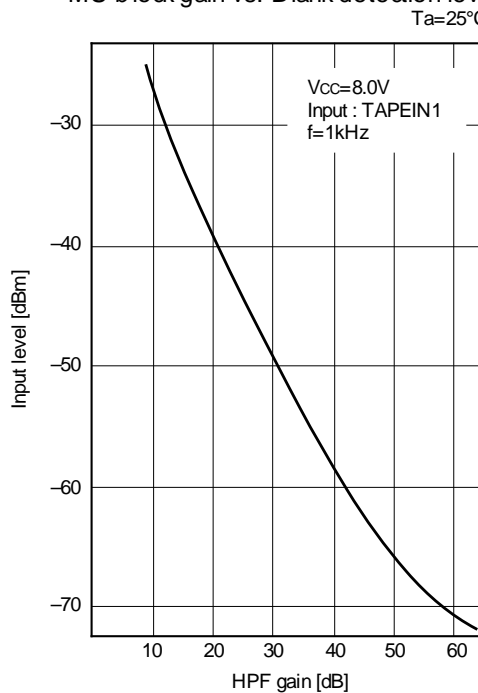

Package Outline Unit : mm

40PIN QFP (PLASTIC)

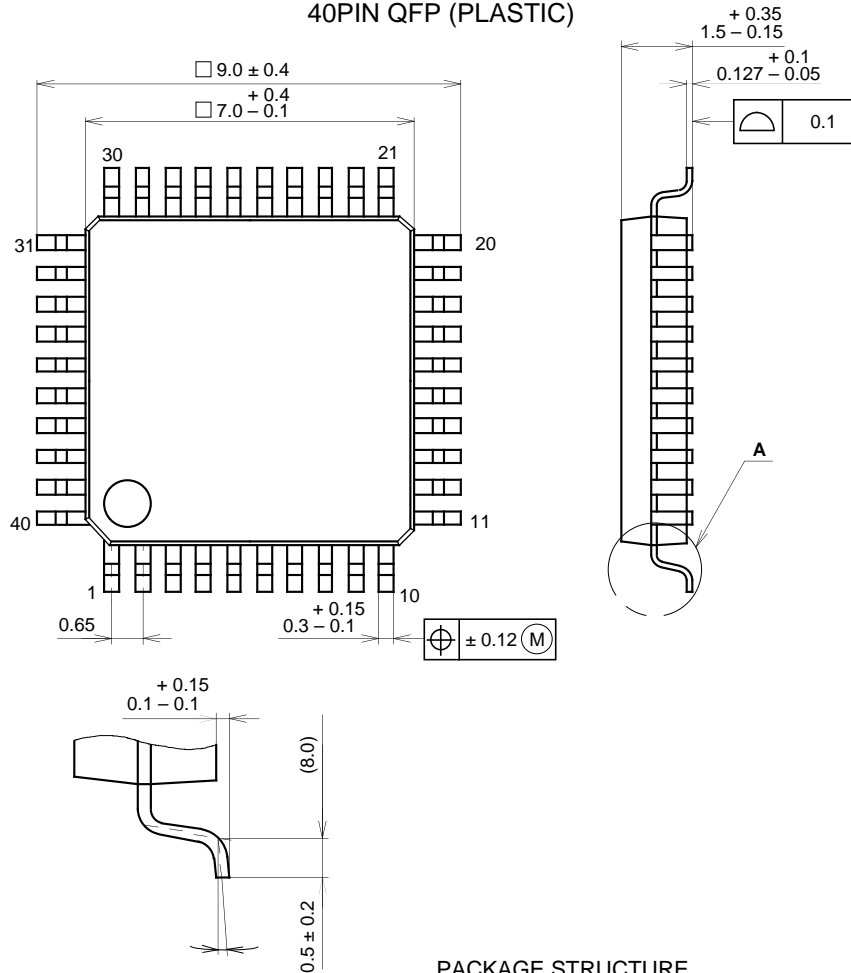

PACKAGE STRUCTURE

PACKAGE MATERIAL	EPOXY RESIN
LEAD TREATMENT	SOLDER / PALLADIUM PLATING
LEAD MATERIAL	COPPER / 42 ALLOY
PACKAGE WEIGHT	0.2g

SONY CODE	QFP-40P-L01
EIAJ CODE	*QFP040-P-0707
JEDEC CODE	_____

This datasheet has been downloaded from:

[www.DatasheetCatalog.com](http://www.DatasheetCatalog.com)

Datasheets for electronic components.



LittleDiode supplies new, hard to find or obsolete electronic components and semiconductors all over the world.

With over two million different components listed you are sure to find the part you need.

Feel free to visit us today at our online store:

[LittleDiode.com](http://LittleDiode.com)

Looking forward to providing you with the best possible service.