

Low-voltage FM IF Amplifier

Description

The CXA1884N is designed for FM communication devices. They incorporate a paging system, mixer, IF limiter, FM detector, operational amplifier, comparator, and others.

Features

- Low operating voltage 1.0 to 4.0V
- Low power consumption 2mA at 1.5V
- Built-in power source voltage monitor

Applications

IF Amplifier for Paging System Receiver

Structure

Bipolar silicon monolithic IC

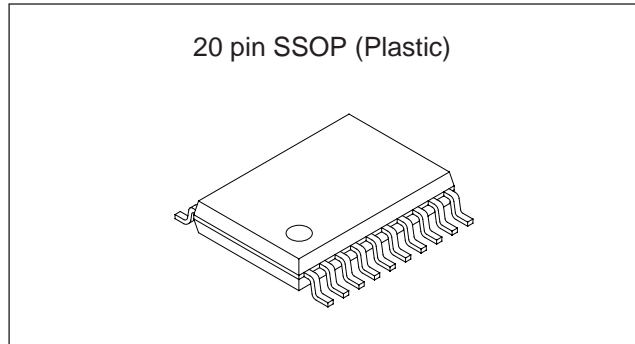

Absolute Maximum Ratings (Ta = 25°C)

- Supply voltage Vcc 7 V
- Operating temperature Topr -20 to +75 °C
- Storage temperature Tstg -65 to +150 °C

Recommended Operating Conditions

- Supply voltage Vcc 1.0 to 4.0 V

Block Diagram and Pin Configuration

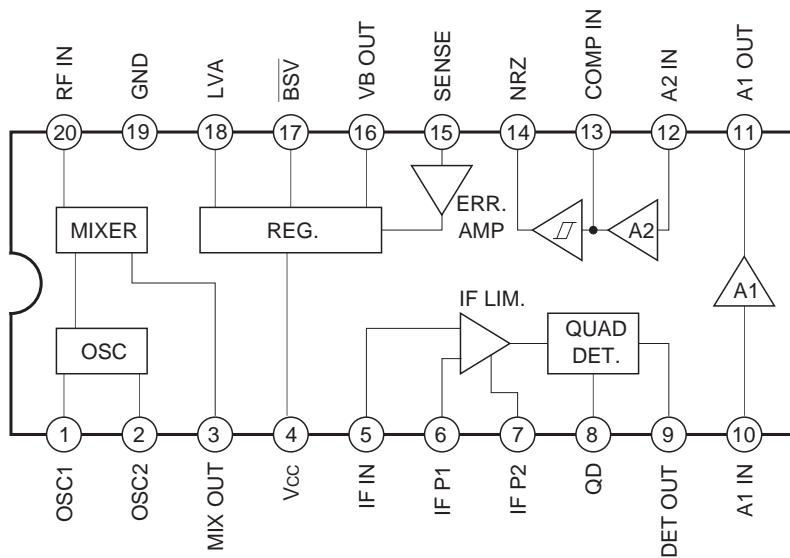

Note) DET. : DETECTOR
 LIM. : LIMITER
 REG. : REGURATOR
 ERR. : ERROR CORRECTION

Sony reserves the right to change products and specifications without prior notice. This information does not convey any license by any implication or otherwise under any patents or other right. Application circuits shown, if any, are typical examples illustrating the operation of the devices. Sony cannot assume responsibility for any problems arising out of the use of these circuits.

Pin Description

Pin No.	Symbol	Equivalent circuit	Description
1	OSC1		<p>Those pins are connected to the external parts of an oscillating circuit. The oscillator is an internally-biased Colpitts type with the collector, base, and emitter connections at Vcc, pins 1 and 2 respectively.</p>
2	OSC2		
3	MIX OUT		<p>Mixer output pin. Connect a 455kHz ceramic filter between this pin and the IF IN pin.</p>
4	Vcc		Vcc pin.
5	IF IN		<p>Input pin for the IF limiter amplifier.</p>
6	IF P1		<p>Connection pin of the bypass capacitor for the IF limiter amplifier. Connect a capacitor of about 0.047μF between this pin and ground (or Vcc).</p>
7	IF P2		<p>Connection pin of the bypass capacitor for the IF limiter amplifier. Connect a capacitor of about 0.047μF between this pin and ground (or Vcc).</p>
8	QD		<p>Connected to a quadrature detector phase shifter.</p>

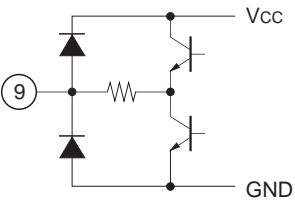
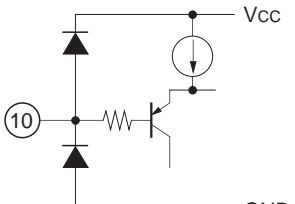
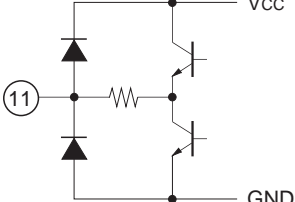
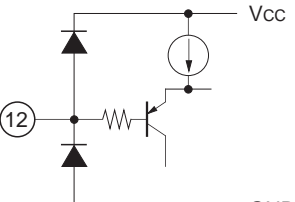
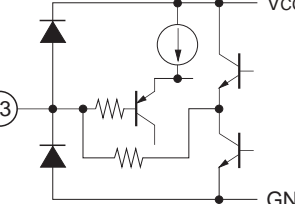
Pin No.	Symbol	Equivalent circuit	Description
9	DET OUT		Recovered signal output.
10	A1 IN		Input pin of inverting OP amplifier A1.
11	A1 OUT		Output pin of OP amplifier A1.
12	A2 IN		Input pin of OP amplifier A2.
13	COMP IN		Input pin of the comparator. This pin is internally connected to the output of OP amplifier A2.

Pin No.	Symbol	Equivalent circuit	Description
14	NRZ		NRZ (Non Return Zero) output pin.
15	SENSE		Voltage control pin for external bias supply.
16	VB OUT		Supplies bias voltage to external circuit transistors and others.
17	\overline{BSV}		Reduces IC power consumption. Lowering pin voltage below 0.35V stops IC operation.
18	LVA		Output pin for Low Voltage Alarm (LVA). The pin turns to high impedance when power voltage drops below 1.05V.
19	GND		Ground pin.
20	RF IN		Mixer input pin.

Electrical Characteristics

(V_{CC} = 1.5V, T_a = 25°C, f_s = 21.7MHz, f_{MOD} = 256Hz, f_{DIV} = 2.3kHz, AM_{MOD} = 30%)

Item	Symbol	Condition	Min.	Typ.	Max.	Unit
Power consumption (during operation)	I _{CC}	Test circuit 1	1.2	2.0	2.6	mA
Power consumption (during battery saving)	I _{CCS}	Test circuit 1 V _I = 0.3V	—	—	20	μA
Input for -3dB Limiting	V _{IN (LIM)}	Test circuit 3	—	7	—	dBμ
AM rejection ratio	AMRR	V _{IN} = 60dBμ Test circuit 3	25	—	—	dB
OP amplifier input bias current	I _{BIAS}	Test circuit 2	—	30	100	nA
OP amplifier open loop gain	A _V	Test circuit 4	45	60	—	dB
OP amplifier output voltage amplitude	V _O	Test circuit 5	0.25	—	—	V _{p-p}
Comparator hysteresis width	V _{TW}	Test circuit 6	30	40	50	mV
NRZ* output leak current	I _{LNZR}	Test circuit 7	—	—	5.0	μA
NRZ* saturation voltage	V _{SATNRZ}	I _{SINK} = 200μA Test circuit 8	—	—	0.4	V
VB output current	I _{OUT}	V _B = 0.9V	0.1	—	—	mA
VB output voltage	V _{BOUT}	Test circuit 9	0.95	—	—	V
Sense voltage	V _{SEN}	Test circuit 2	85	100	115	mV
LVA threshold voltage	V _{PML}	Test circuit 10	1.00	1.05	1.10	V
LVA hysteresis width	V _{PMTH}	V _{PMH} - V _{PML}	35	50	70	mV
LVA output leak current	I _{LLVA}	Test circuit 7	—	—	5.0	μA
LVA saturation voltage	V _{SATLVA}	Test circuit 8	—	—	0.4	V
Recovered signal voltage	V _{DET}	Test circuit 3	10	—	—	mV _{rms}
BSV high level	V _{THBSV}		0.95	—	—	V
BSV low level	V _{TLBSV}		—	—	0.35	V

* NRZ: Non Return Zero

Electrical Characteristics Test Circuit

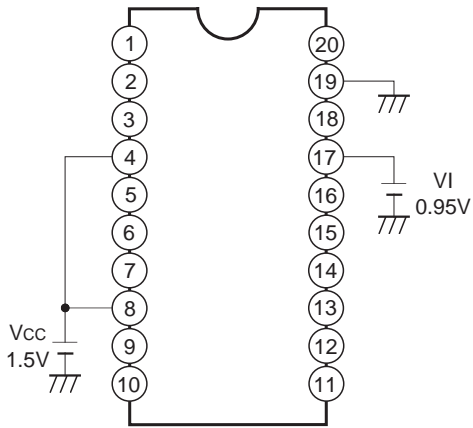

Test circuit 1

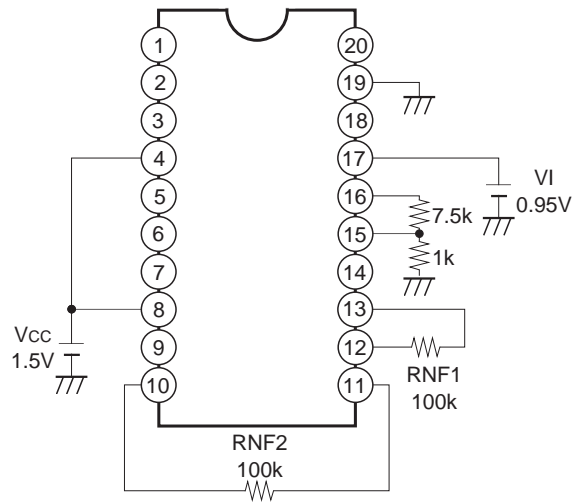

Test circuit 2

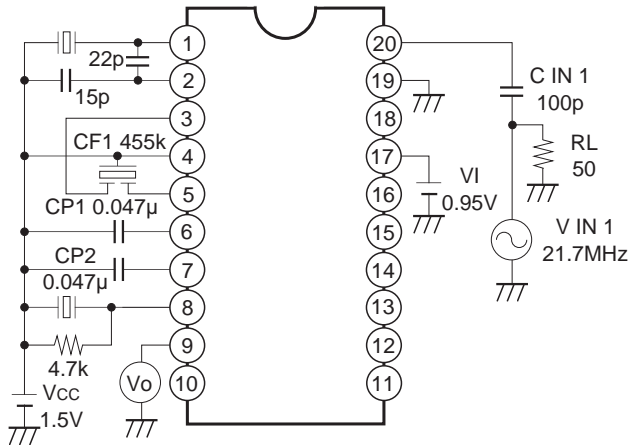

Test circuit 3

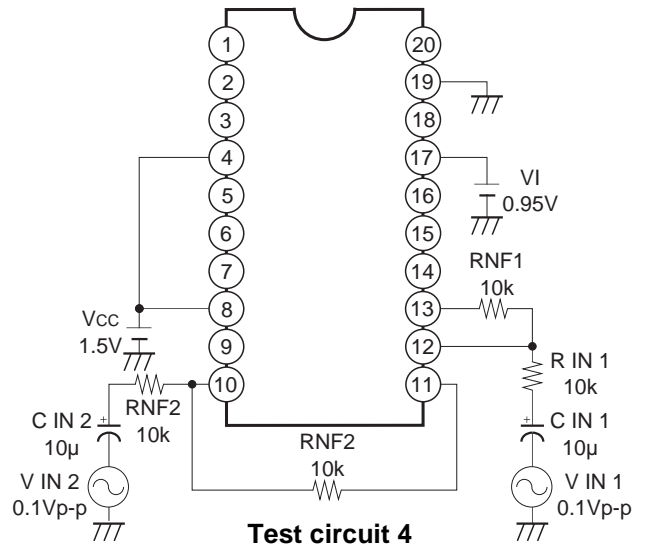

Test circuit 4

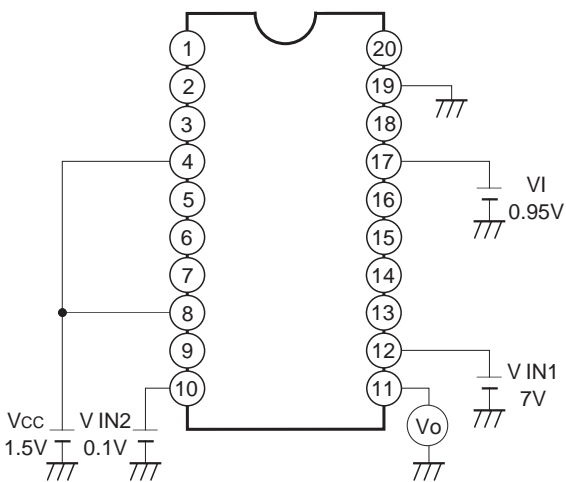

Test circuit 5

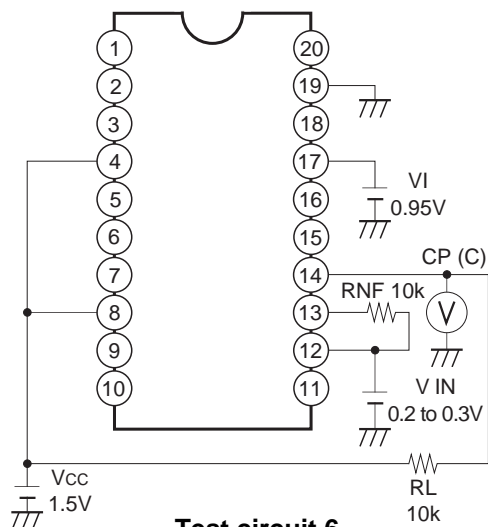

Test circuit 6

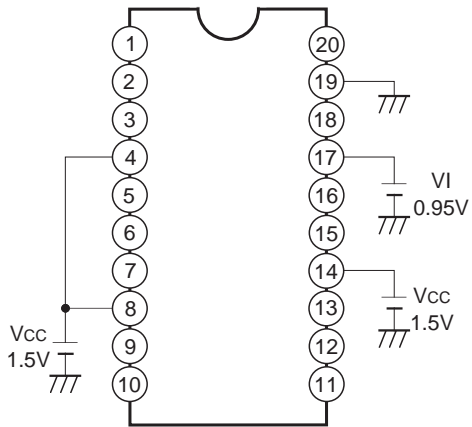

Test circuit 7

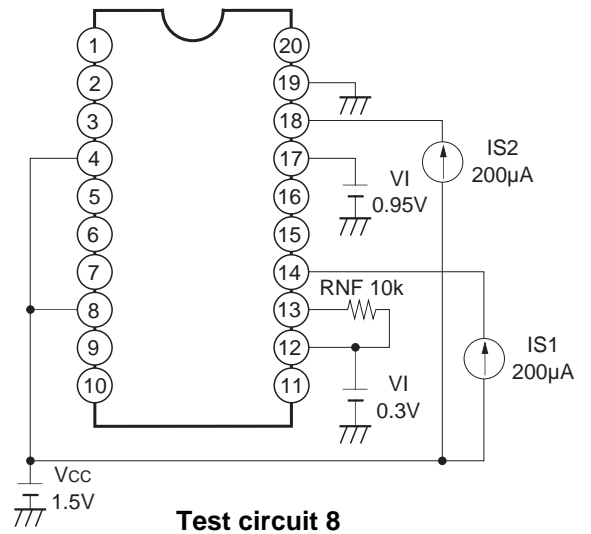

Test circuit 8

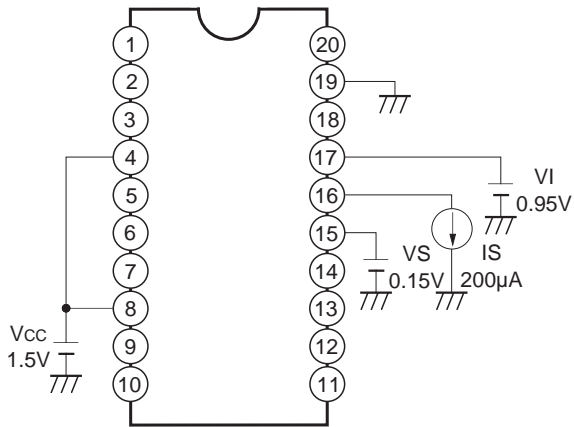

Test circuit 9

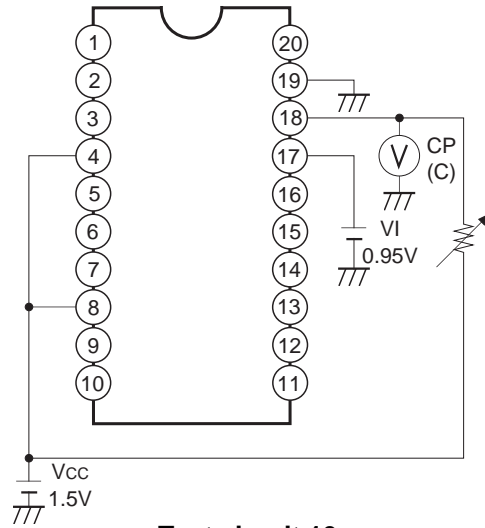

Test circuit 10

Test Method

Input for –3dB Limiting V_{IN} (LIM)

Use test circuit 3. Apply a signal with the following characteristics to SIG IN.

Signal frequency: $f_s = 21.7\text{MHz}$ Modulation frequency: $f_{MOD} = 256\text{Hz}$
 Frequency deviation: $f_{DIV} = 2.3\text{kHz}$ Signal level: $V_L = 40\text{dB}\mu$

Here, the value of V_{AC} is specified as V_{AC1} . Next, the signal level V_L is changed to $19\text{dB}\mu$ and V_{AC} value is hence specified as V_{AC2} .

$$20 \log \frac{V_{AC1}}{V_{AC2}} < 3\text{dB}$$

AM rejection ratio (AMRR)

Use test circuit 3. Apply a signal with the following characteristics to SIG IN.

Signal frequency: $f_s = 21.7\text{MHz}$ Modulation frequency: $f_{MOD} = 256\text{Hz}$
 Frequency deviation: $f_{DIV} = 2.3\text{kHz}$ Signal level: $V_L = 40\text{dB}\mu$

Here, the value of V_{AC} is specified as V_{AC1} . Next, AM is modified to:

Modulation ratio: $AM_{MOD} = 30\%$ Modulation frequency: $f_{MOD} = 256\text{Hz}$

and the V_{AC} value is hence specified as V_{AC2} .

$$AMRR = 20 \log \frac{V_{AC1}}{V_{AC2}} > 25\text{dB}$$

Recovered signal voltage V_{DET}

Use test circuit 3. Apply a signal with the following characteristics to SIG IN.

Signal frequency: $f_s = 21.7\text{MHz}$ Modulation frequency: $f_{MOD} = 256\text{Hz}$
 Frequency deviation: $f_{DIV} = 2.3\text{kHz}$ Signal level: $V_L = 50\text{dB}\mu$

Here, the value of the Pin 9 output voltage is expressed as V_{DET} .

OP amplifier output voltage amplitude V_o

Use test circuit 5. If output voltage V is expressed as V_1 when V_{IN} is 0.1V , and as V_2 when V_{IN} is 0.3V , it follows that:

$$V_o = V_1 - V_2$$

Comparator hysteresis width V_{TW}

Use test circuit 6. Vary V_{IN} between 0.1 to 0.3V .

Specify V_{IN} voltage, as V_1 when (C) voltage changes from low to high.

Similarly, specify V_{IN} voltage as V_2 , when (C) voltage changes from high to low.

$$\text{Therefore: } V_{HY} \quad V_{TW} = V_1 - V_2$$

LVA threshold voltage V_{PML} and recovery voltage V_{PMH}

Use test circuit 10. Vary power voltage V_{CC} from 1.3 to 0.95V .

Specify V_{CC} as V_{PML} , when (C) voltage changes from low to high.

Similarly, specify V_{CC} as V_{PMH} , when (C) voltage changes from high to low.

Design Reference Values

(Ta = 25°C, Vcc = 1.4V)

Item	Symbol	Condition	Min.	Typ.	Max.	Unit
Mixer input resistance	R _{IN (MIX)}		1.3	1.6	1.9	kΩ
Mixer input capacity	C _{IN (MIX)}		—	4.0	—	pF
Mixer output resistance	R _{OUT (MIX)}		1.44	1.8	2.16	kΩ
IF input resistance	R _{IN (IF)}		1.44	1.8	2.16	kΩ
IF gain stability	G _{N (IF)}	Ta = -20 to +60°C	—	±6	—	dB
Detector output resistance	R _{OUT (QD)}		1.28	1.6	2.0	kΩ
OP amplifier max. input voltage	V _{INMAX}		—	—	0.39	V
OP amplifier min. input voltage	V _{INMIN}		0.05	—	—	V
Comparator max. input voltage	V _{INMAXCOMP}		—	—	0.39	V
Comparator min. input voltage	V _{INMINCOMP}		0.05	—	—	V
OP amplifier off-set voltage	V _{OFS}		—	—	3	mV

Application Circuit

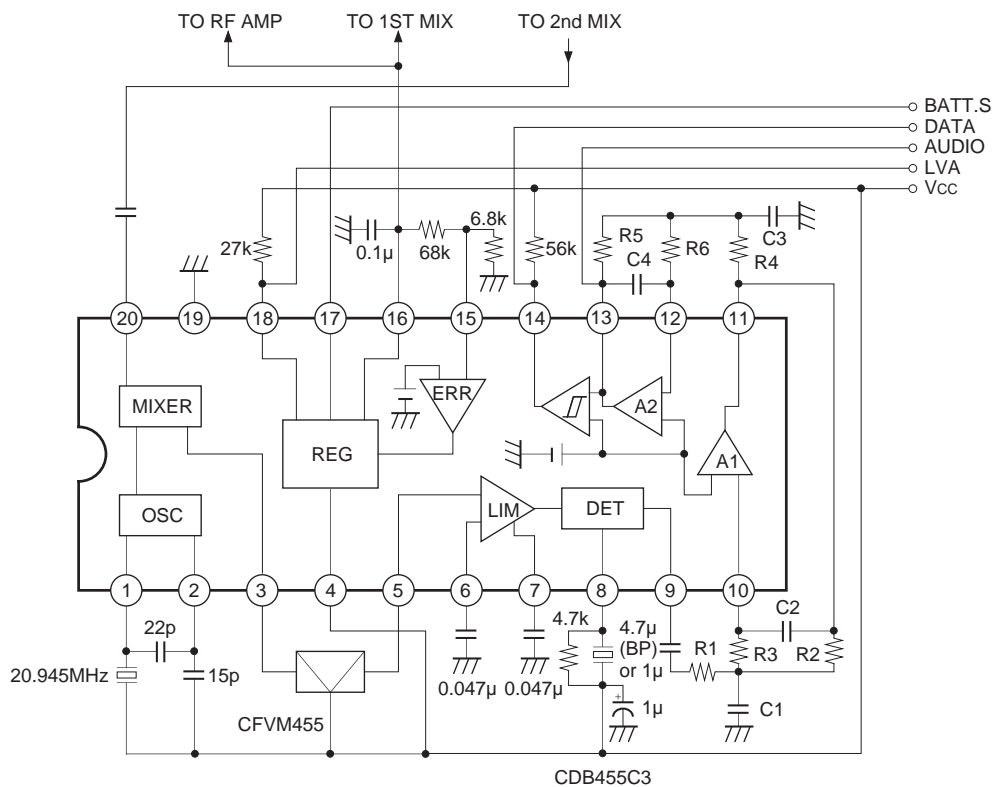

Application circuits shown are typical examples illustrating the operation of the devices. Sony cannot assume responsibility for any problems arising out of the use of these circuits or for any infringement of third party patent and other right due to same.

1) Supply

This IC incorporates a regulation and is designed to operate steadily on a wide range of supply voltage from 1.0 to 4.0V.

Decoupling on the wiring to the supply pin (Pin 4) should be done as close to the pin as possible.

2) Oscillation input

Oscillation input method

- (a) Using Pins 1 and 2, input self-excited oscillation signals through the composition of a Colpitts type crystal oscillating circuit.
- (b) Input local oscillation signals to Pin 1 directly.

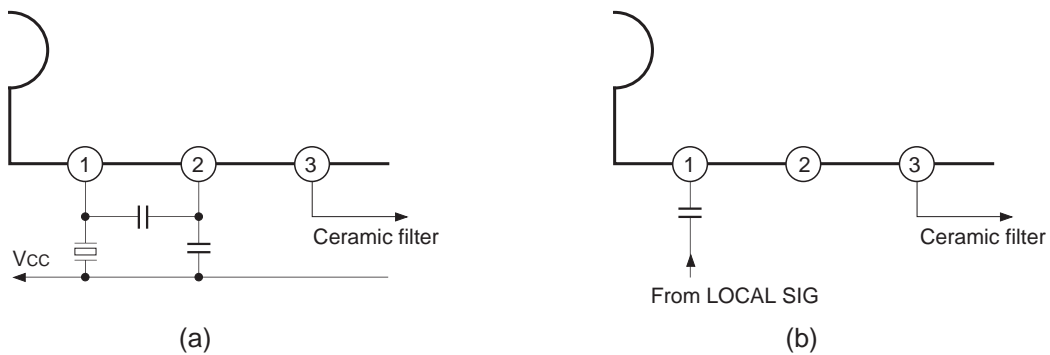

Fig. 1

3) Mixer

This IC's mixer is of the double balance type. Pin 24 is the input pin. Input through a suitable alignment circuit. Input impedance is at 1.6k Ω . The mixer output features a built-in 1.6k Ω load resistance at Pin 3.

4) IF filter

The filter to be connected between this IC's mixer and the IF limiter should have the following specifications.

I/O impedance: 1.6k Ω \pm 10%

Band width: Use according to application

5) IF limiter

The IF limiter of this IC features a gain of about 100dB. To this effect, the following points should be considered for the wiring connecting IF limiter input pin (Pin 5) and decoupling capacitor pins (Pins 6 and 7).

- (a) Wiring to mixer output (Pin 3) and IF limiter input (Pin 5) should be as short and as far apart as possible to avoid neutral interference.
- (b) Connect a decoupling capacitor to IF limiter IF P1 (Pin 6) and IF P2 (Pin 7). Here the decoupling capacitor should be positioned as close as possible to each pin and the wiring be as short as can be.
- (c) As IF limiter output shows at QD (Pin 8), keep the wiring connected to QD pin R, L, C and the ceramic discriminator as short as possible. Interference to the mixer output, IF limiter input and others must be kept to a minimum.

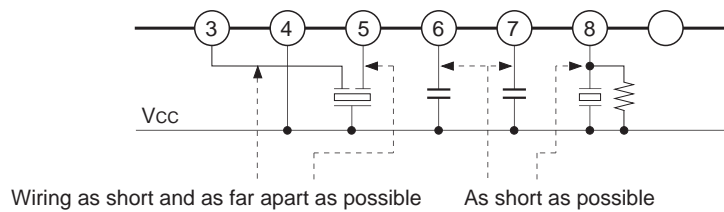

Fig. 2

6) Detector

The detector is of the quadrature type. To phase shift, either R, L, C resonance circuit or the ceramic discriminator is connected to Pin 8.

The phase capacitor of the quadrature detector is built-in. FM (FSK) signals demodulated by this detector have their high frequency components dropped by the LPF formed inside from CRs, to be output at DET OUT (Pin 9). DET OUT output impedance is about 3kΩ.

For the CXA1884N ceramic discriminator, CDB 455 C3 (Murata Production) is recommended.



Fig. 3

7) OP AMP, NRZ OUT

This IC has 2 built-in operation amplifiers.
 One of these operation amplifiers is connected inside the IC to NRZ comparator.

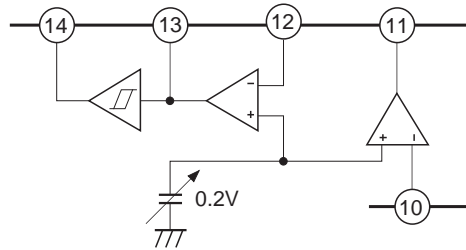

Fig. 4

Making use of these operation amplifiers an LPF or the sort is made up to eliminate noise during signal demodulation and input to the following NRZ comparator.

NRZ comparator molds the waveform of input signals to output them as square waves. NRZ comparator output is an open collector.

Accordingly as CPU is a CMOS, in case the supply voltage differs, by following the method indicated in Fig. 5 direct interfacing becomes possible.

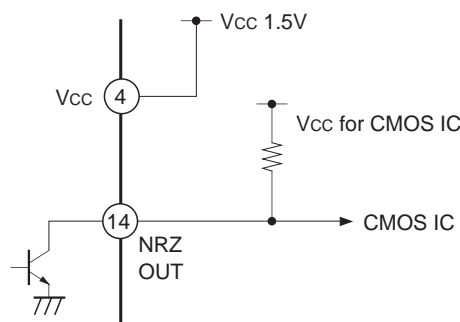

Fig. 5

8) VB SENSE, VB OUT

This controls the base bias of the external transistor. Pin 16 VB OUT can be used as the previous amplifier 1st mixer bias.

9) LVA OUT

When supply voltage turns low this pin turns to High (Open). Output is an open collector, and similarly as NRX OUT, can directly drive CMOS.

This LVA setting voltage is at $1.05V \pm 50mV$ with hysteresis versus supply voltage.

Hysteresis width is at $50mV \pm 10mV$.

10) $\overline{\text{BSV}}$

By turning this pin to low, this IC's operation can be stopped.

This pin can also be directly connected to CMOS.

Consumption current with $\overline{\text{BSV}}$ is 20 μA (at 1.5V) and below.

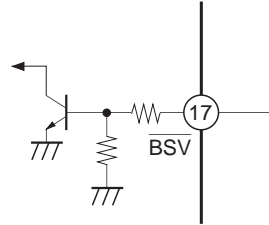
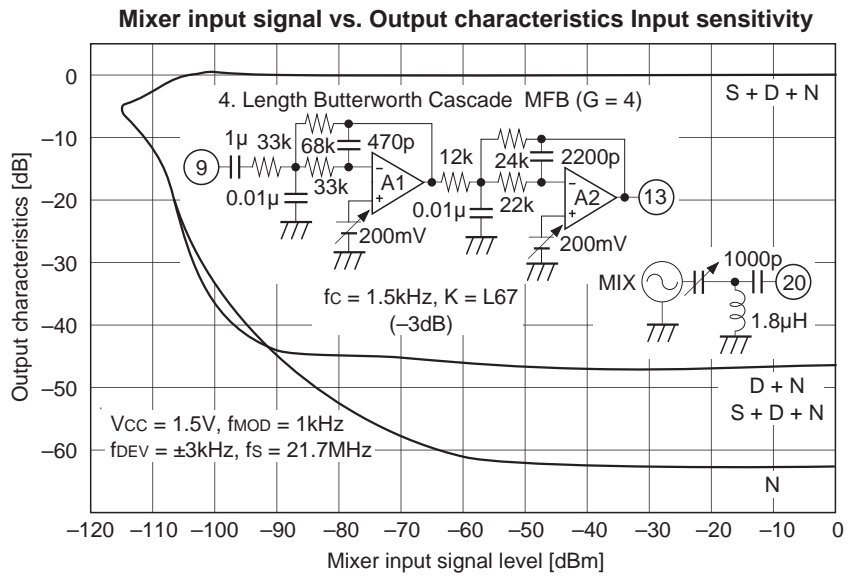
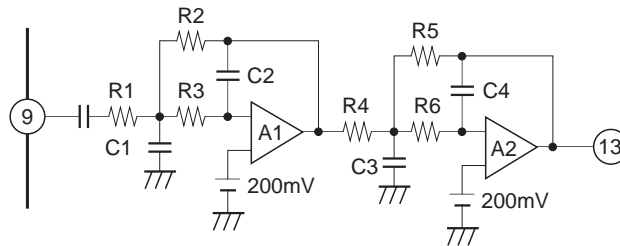

Fig. 6



4th LP Butterworth cascade MFB constant using OP1 and OP2 inside CXA1884N



fMOD	256Hz
fc (-3dB)	400Hz
A1 Gain	1
A2 Gain	4
R1	47kΩ
R2	47kΩ
R3	22kΩ
R4	47kΩ
R5	180kΩ
R6	33kΩ
C1	0.012µF
C2	680pF
C3	0.015µF
C4	1200pF

Supply voltage vs. Consumption current

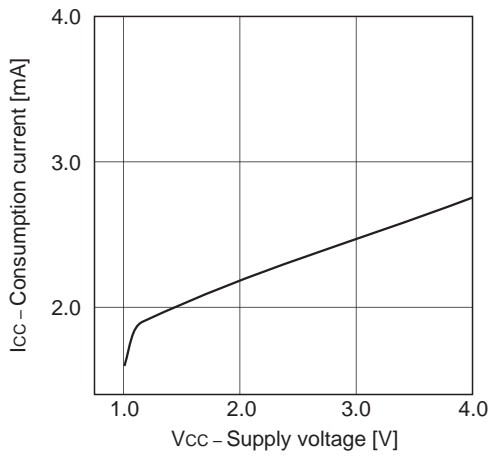

Logical input level vs. Mixer conversion

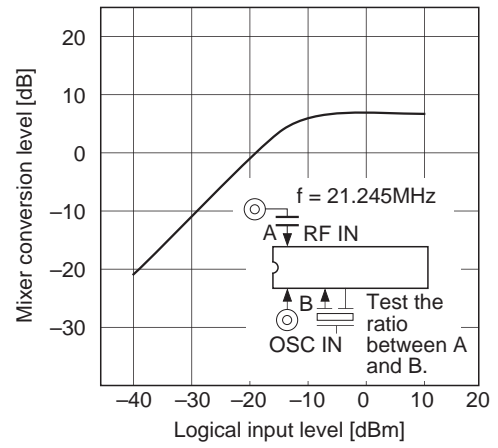

Input frequency vs. Conversion gain

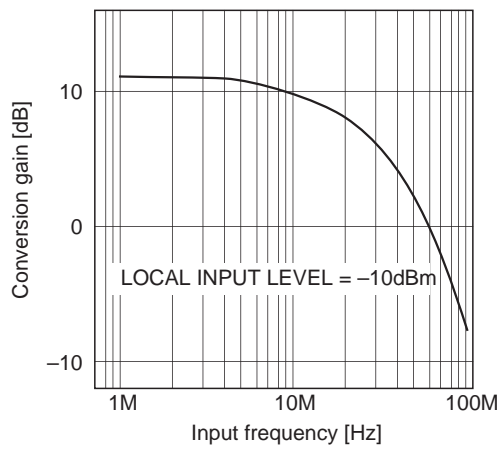

Package Outline Unit: mm

20PIN SSOP (PLASTIC)

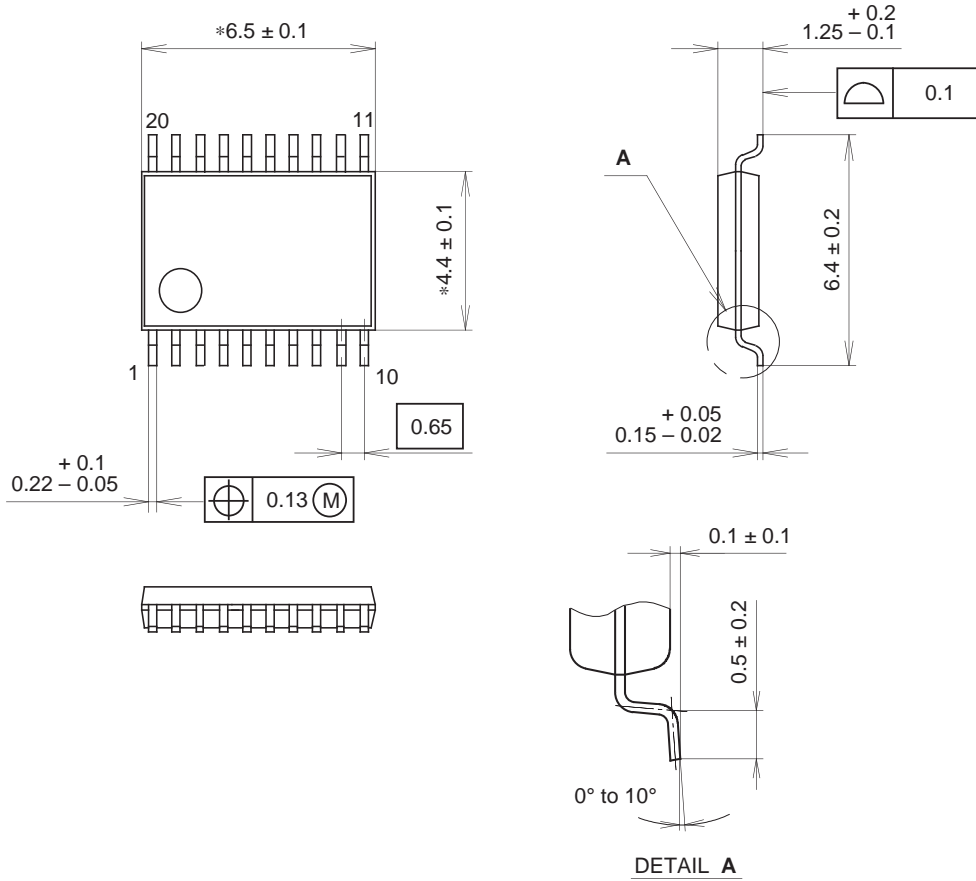

NOTE: Dimension "*" does not include mold protrusion.

PACKAGE STRUCTURE

SONY CODE	SSOP-20P-L01
EIAJ CODE	SSOP020-P-0044
JEDEC CODE	_____

PACKAGE MATERIAL	EPOXY RESIN
LEAD TREATMENT	SOLDER / PALLADIUM PLATING
LEAD MATERIAL	42/COPPER ALLOY
PACKAGE MASS	0.1g

NOTE : PALLADIUM PLATING
This product uses S-PdPPF (Sony Spec.-Palladium Pre-Plated Lead Frame).



LittleDiode supplies new, hard to find or obsolete electronic components and semiconductors all over the world.

With over two million different components listed you are sure to find the part you need.

Feel free to visit us today at our online store:

LittleDiode.com

Looking forward to providing you with the best possible service.