

8ch. Read/Write Amplifier for Thin Film Heads of Hard Disk Drive

Description

The CXA1829N is a Read/Write amplifier for hard disk drive thin-film heads and is designed to handle up to 8-channel heads.

Features

- Operates on a single 5V power supply.
- Low power consumption.
 Read: 115 mW
 Write ($I_w = 15 \text{ mA}$): $160 \text{ mW} + I_w \times 5$
 Power Save: 7 mW
- Write current can be varied through an external resistor. Built-in stabilizer circuit provides stable current, preventing voltage and temperature drift.
- Drives up to 8 heads.
- Supports thin film heads or 2-pin MIG heads.
- Emitter follower-type Read amplifier features 290 times gain (typ.).
- Write-unsafe detection circuit.
- Damping resistance is switched at Write (315Ω).
- Simultaneous Write function.
- Supply voltage monitor circuit prohibits error writing during power surge or abnormal voltage.
- IC protection circuit for head-to-ground short circuit protection.
- Differential input capacitance at Read: 14 pF (typ.).
- Write data input minimum pulse width: 10 ns
- Read data output in Write mode becomes a high impedance due to the improved Read data offset when Write is switched to Read.
- Non-selected head DC voltage falls to GND level.

Structure

Bipolar silicon monolithic IC

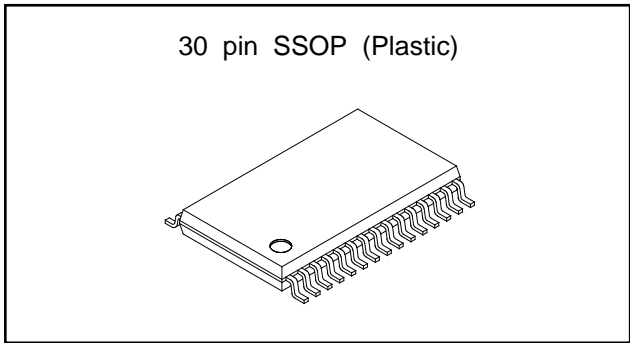

Absolute Maximum Ratings (Ta=25°C)

• Supply voltage	VCC	7.0	V
• Write current	Iw	20	mAo-p
• Operating temperature	Topr	-20 to +75	°C
• Operating temperature at Simultaneous Write	Topr	-20 to +30	°C
• Storage temperature	Tstg	-55 to +150	°C
• Allowable power dissipation	Pd	480	mW

Recommended Operating Conditions

• Supply voltage	VCC	5V±10%	V
------------------	-----	--------	---

Sony reserves the right to change products and specifications without prior notice. This information does not convey any license by any implication or otherwise under any patents or other right. Application circuits shown, if any, are typical examples illustrating the operation of the devices. Sony cannot assume responsibility for any problems arising out of the use of these circuits.

Block Diagram and Pin Configuration

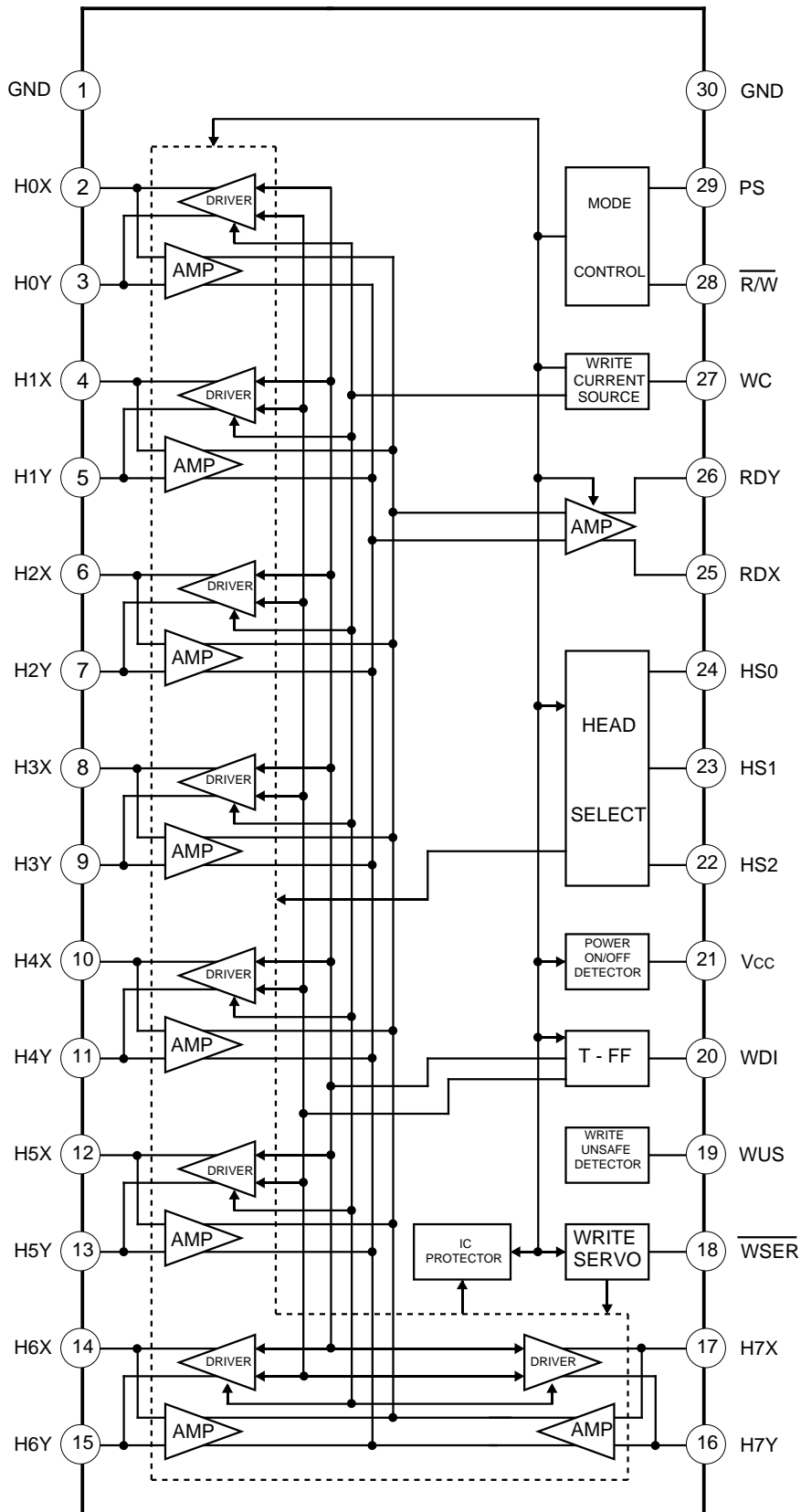

Pin Description

No.	Symbol	Equivalent circuit	Description
1, 30	GND		GND connection.
2, 3 4, 5 6, 7 8, 9 10, 11 12, 13 14, 15 16, 17	H0X, H0Y H1X, H1Y H2X, H2Y H3X, H3Y H4X, H4Y H5X, H5Y H6X, H6Y H7X, H7Y		Head input. 8 channels provided.
19	WUS		Write-unsafe detection output. Open collector output. When it is high in Write mode, an error is detected.
20	WDI		Write data input. When high changes to low, input is triggered.
21	Vcc		5 V power supply.
22 23 24	HS2 HS1 HS0		Head select signal input. Eight heads are selected as shown in Table 2.
28	R/W		Read/Write signal input. Read at high; Write at low.
29	PS		Power save signal input. Power save at high.

No.	Symbol	Equivalent circuit	Description
18	$\overline{\text{WSER}}$		<p>Simultaneous Write signal input. Set to low for simultaneous Write mode.</p>
25 26	RDX RDY		<p>Read amplifier output. Becomes a high impedance at Write.</p>
27	WC		<p>A setting resistor for the Write current value is connected between this pin and GND.</p>

Electrical Characteristics (unless otherwise specified, VCC = 5 V, Ta = 25°C, Write current Iw = 15 mA)

Refer to Measurement Circuit 1.

Item	Symbol	Measurement conditions	Measurement point	Min.	Typ.	Max.	Unit
Current consumption for Read	IR	R/W="H"	E	17	23	33	mA
Current consumption for Write	Iw	R/W="L"	E	24 +Iw	32 +Iw	45 +Iw	
Current consumption for Servo	ISE	W/SER="L"	E	71 +4xIw	91 +4xIw	111 +4xIw	
Current consumption for Power save	IP	PS="H"	E	0.8	1.4	2.0	
Digital low input voltage	VIL		B D			0.8	V
Digital high input voltage	VIH			F G H I J	2.0		
Digital low input current	IL	High applied voltage: 5 V			-70		
Digital high input current	IH	Low applied voltage: 0 V				70	
Write-unsafe output saturation voltage	VWUS	Output current: 1 mA	C			0.5	V
Write-unsafe output leak current	IwUS		C			10	μA
Power ON/OFF detector threshold voltage	VTH		VCC A	3.6	3.9	4.3	V
Write current setting range	Iw	Current flowing between head pins.	A	5		15	mAo-p
Write current accuracy	ΔIw	When Write current is Iw [mA], then: $Iw = \frac{K}{Rw} (Rw: \Omega)$, Refer to Fig. 12 (Characteristics) for K.	A	-8		8	%
Read amplifier differential voltage gain	Av	Input voltage SG1:1mVp-p,300kHz Load resistance (RDX, RDY): 1kΩ	K	245	290	335	V/V
Bandwidth (-3 dB)	BW	Frequency at which Av drops by 3dB	K	60			MHz
Input conversion noise voltage	EN	Head impedance: 0 Ω	K		0.55	0.7	$\frac{nV}{\sqrt{Hz}}$
Common mode rejection ratio	CMRR	In-phase input voltage SG2:100mVp-p, 10 MHz	K	50	77		dB

Refer to Measurement Circuit 1.

Item	Symbol	Measurement conditions	Measurement point	Min.	Typ.	Max.	Unit
Supply voltage rejection ratio	PSRR	Ripple voltage SG3: $5\text{ V} \pm 100\text{ mVp-p}$, 10 MHz When Read amplifier output is V_p (mVp-p), then: $\text{PSRR} = 20 \log (100/V_p)$ $+ 20 \log A_v$	K	45	55		dB
Channel separation	CS	Selected head input voltage: 0 mVp-p Non-selected head input voltage SG1: 100 mVp-p , 10 MHz When Read amplifier output is V_{cs} (mVp-p), then: $\text{CS} = 20 \log (100/V_{cs}) +$ $20 \log A_v$	K	45	55		
Non-selected head voltage	V_{HUS}		Non selected head			0.2	V

Unless otherwise specified, $V_{CC} = 5\text{ V}$, $T_a = 25\text{ }^\circ\text{C}$, f_{WD} (Write data frequency) = 5 MHz, $I_W = 15\text{ mA}$, L_H (head inductance) = 1 μH , R_H (head DC resistance) = 30 Ω

Refer to Measurement Circuit 2 and Timing Chart.

Item	Symbol	Measurement conditions	Min.	Typ.	Max.	Unit
Head differential voltage amplitude	V _{SW}	Potential difference between HX and HY pins when Write current is switched.	4.4	5.2		Vp-p
Write-unsafe detection maximum frequency	F _{WUS}	F _{WUS} is the Write data frequency when WUS pin is high in Write mode.		280	1000	kHz
Mode switching time Read to Write	T _{RW}	Time required for Write current to reach 90% after Read mode is switched to Write mode.			0.6	μs
Mode switching time Read to Simultaneous Write	T _{RS}	Time required for Write current to reach 90% after Read mode is switched to Simultaneous Write mode.			0.6	
Mode switching time Write to Read	T _{WR}	Time required for Write current to reach 10% after Write mode is switched to Read mode.			0.6	
Mode switching time Safe to Unsafe	T _{SA1}	Time required for WUS pin to become high after the Write data is stopped in Write mode.	3	7	11	
Mode switching time Unsafe to Safe	T _{SA2}	Time required for WUS pin to become low after the Write data is input in Write mode.			1.0	
Mode switching time Power save to Read	T _{PR}	Time required for RD output to reach 90% after Power Save mode is switched to Read mode.			1.0	
Head switching time	T _H	Time required for RD output to reach 90% when the selected head is changed in Read mode.			0.6	
Write current propagation delay time	T _{PD}	LH = 0, RH = 0 Time required for Write current to reach 90% after the Write data falling edge.		16	30	
Write current rise/fall time	T _R /T _F	LH = 0, RH = 0 T _R is the time required for Write current to reach 90% from 10%; T _F is the time required for it to reach 10% from 90%.		5	10	

Timing Chart 1

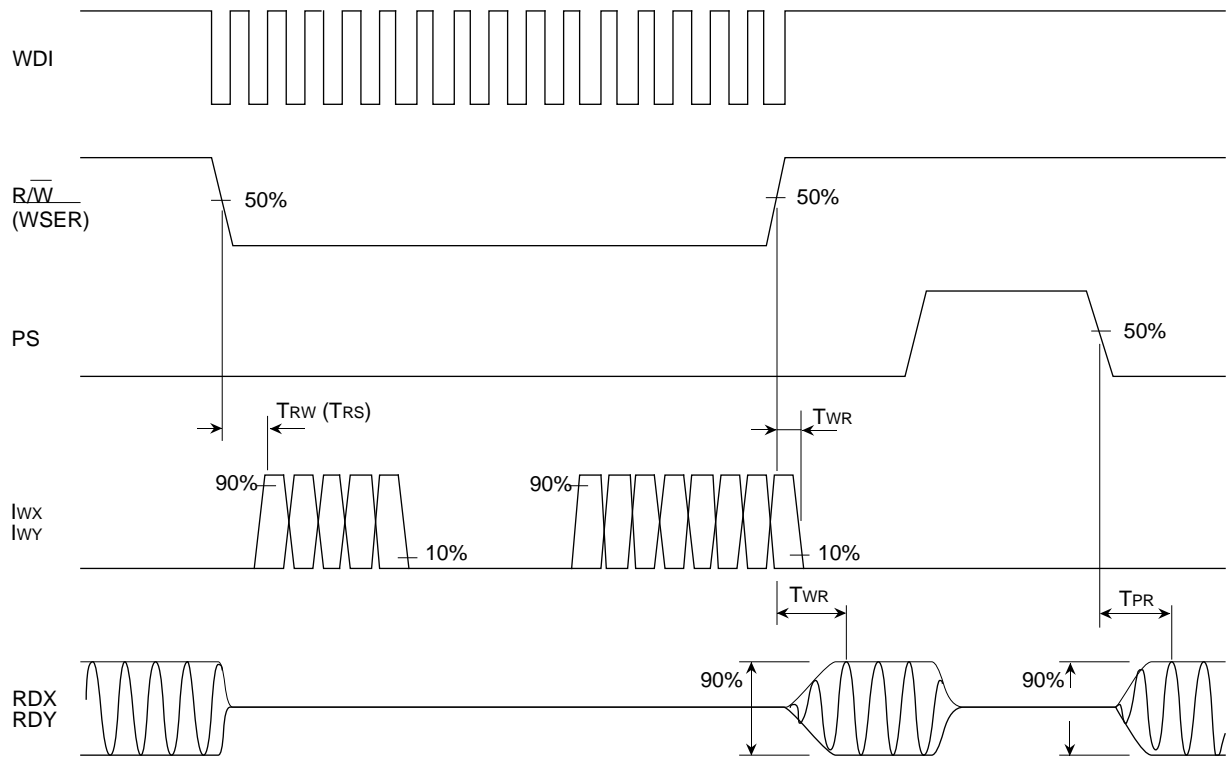

Fig. 3

Timing Chart 2

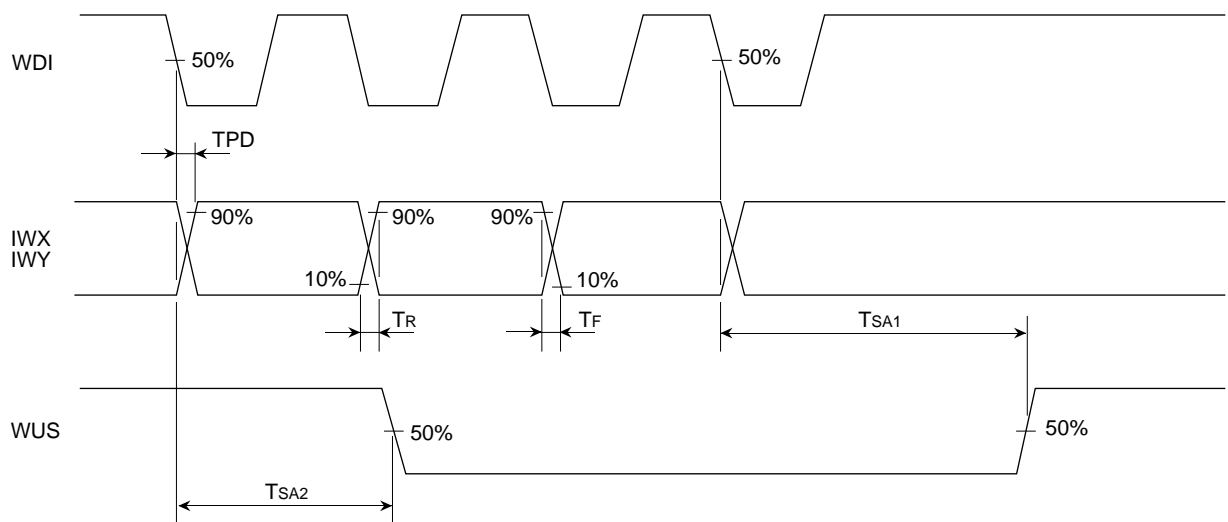

Fig. 4

Description of Functions

Read amplifier

This is a low-noise amplifier for amplifying the faint signals from the heads, and is an emitter follower output. It outputs the signals differentially to the RDX and RDY pins, and the X side of the head and RDX pin and the Y side of the head and RDY pin have the same polarity. RDX and RDY outputs in Write mode become high impedance. (The outputs should be capacitor-coupled.)

Write circuit

The Write data input to the WDI pin passes through a T flip-flop where its frequency is halved. It then drives the Write switch circuit and supplies the Write current to the heads.

The Write data is triggered at the transition from high to low and the Write current is switched.

The Write current flows from the X side when the mode changes from Read to Write.

Mode control

The modes are set as shown in Table 1 by the $\overline{R/W}$, PS and \overline{WSER} pins.

Table 1. Mode selection

$\overline{R/W}$	PS	\overline{WSER}	HSO	Mode
L	L	H	X	Write
H	L	H	X	Read
X	H	X	X	Power save
X	L	L	L	0, 2, 4, 6-head simultaneous Write
X	L	L	H	1, 3, 5, 7-head simultaneous Write

The \overline{WSER} pin has a built-in pull-up resistor (100 k Ω).

Head selection

The heads are selected as shown in Table 2 by the HS0, HS1 and HS2 pins.

Table 2. Head selection

HS0	HS1	HS2	Head
L	L	L	0
H	L	L	1
L	H	L	2
H	H	L	3
L	L	H	4
H	L	H	5
L	H	H	6
H	H	H	7

Write-unsafe detection circuit (refer to the “Notes on Operation.”)

This circuit detects write errors.

In normal Write mode, the WUS output is low; in the conditions listed below, it is high.

- Head input is open.
- Head input is shorted to GND or Vcc.
- Write data frequency is abnormally low.
- There is no Write current.
- In Read mode
- In Power save mode
- Supply voltage is abnormal (refer to the “Power supply ON/OFF detection.”)

Power supply ON/OFF detection

This circuit monitors Vcc to detect erroneous Writes.

The error status is established when Vcc falls below the threshold voltage (V_{TH}) of the power supply ON/OFF detector, in which case the recording and playback functions are prohibited.

When Vcc rises above V_{TH}, the prohibition of these functions is released.

Application Circuit

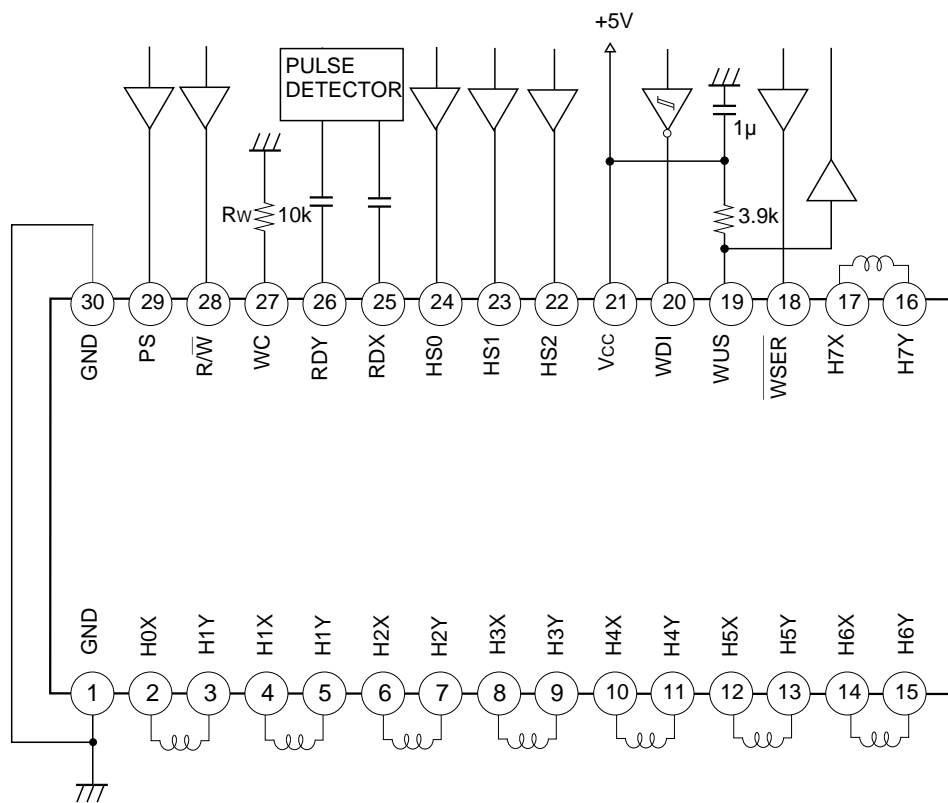

Fig. 5

Application circuits shown are typical examples illustrating the operation of the devices. Sony cannot assume responsibility for any problems arising out of the use of these circuits or for any infringement of third party patent and other right due to same.

Notes on Operation

- This IC handles high frequency and high gain signals. Please note the following;
 - ◇ Connect VCC decoupling capacitor of approximately 1000 pF near the IC.
 - ◇ Make the grounding area as large as possible.
- Short-circuit the X and Y sides of unused head pins or leave them open.
- Write data pulse width
 - Set the pulse width to 10 ns or more at 1.5 V to prevent misoperation.
- The WC pin is a constant voltage pin. When noise affects this pin, it creates noise in Write current. Therefore, locate R_w as close to the IC as possible.
- Write-unsafe detection circuit
 - The WUS detection circuit operates by voltage waveform of head pin.

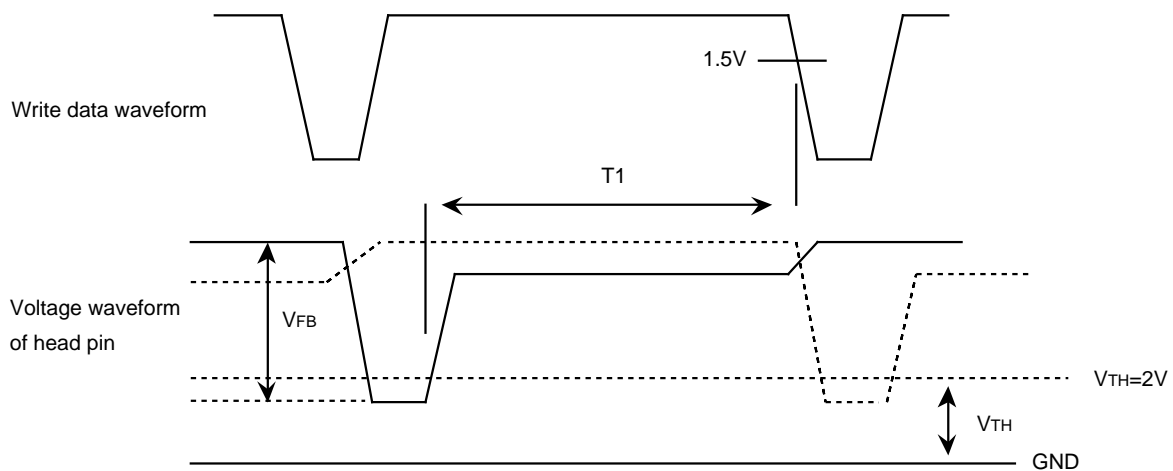

Fig. 6

- ◇ Use the IC at $T_1 > 10$ ns for normal operation of the WUS detecting circuit.
- ◇ Use the IC with V_{FB} of 2V or more. If the V_{FB} is less than 2V, the write-unsafe detection maximum frequency may become 1 MHz or more.
- ◇ Please apply to the reference mentioned on this back cover since the operation range of the write-unsafe detection circuit is greatly affected by the head inductance, head DC resistance and Write current.
- Use the IC with T_a at 30°C or less in Simultaneous Write mode.

Application Notes

Use the following characteristics for reference.

VCC=5V, Ta=25°C

Item		Symbol	Measurement conditions	Min.	Typ.	Max.	Unit
Write mode	Differential output capacitance	C ₀	Between head input pins			15	pF
	Differential output resistance	R ₀		235	315	395	Ω
Read mode	Differential input capacitance	C ₁	Between head input pins		14	20	pF
	Differential input resistance	R ₁		0.7	1.4		kΩ
	Output resistance	R _{RD}	RDX or RDY		40	60	Ω
Non-selected head differential current in Write mode		I _{US}	LH=1μH, RH=30Ω I _W =15mA			0.2	mAp-p
Write current symmetry		T _{AS}	LH=0μH, RH=0Ω I _W =15mA	-1		1	ns

Example of Representative Characteristics

Fig. 7 Normalized Write current vs. Supply voltage

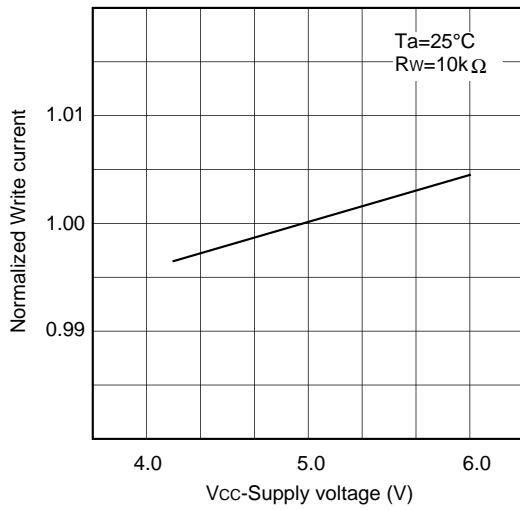

Fig. 8 Normalized Write current vs. Ambient temperature

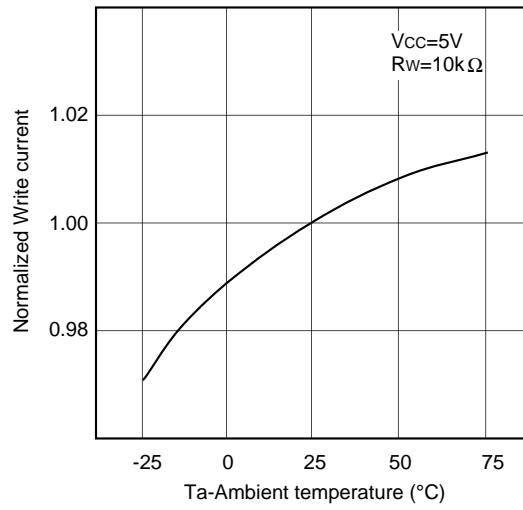

Fig. 9 Normalized Read amplifier differential voltage gain vs. Supply voltage

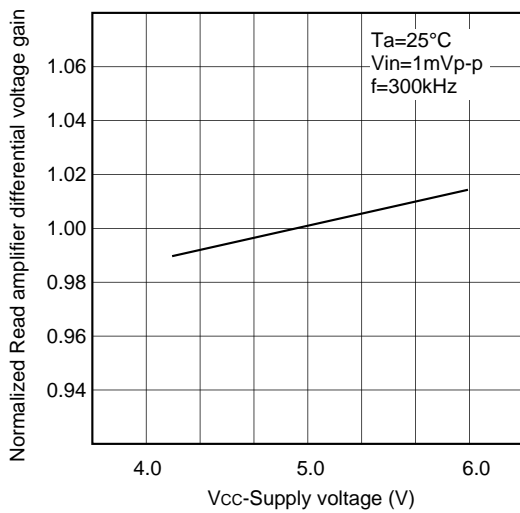

Fig. 10 Normalized Read amplifier differential voltage gain vs. Ambient temperature

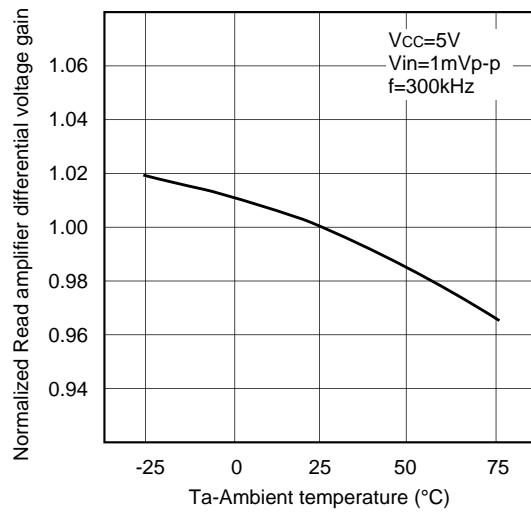

Fig. 11 Power supply ON/OFF detector threshold voltage vs. Ambient temperature

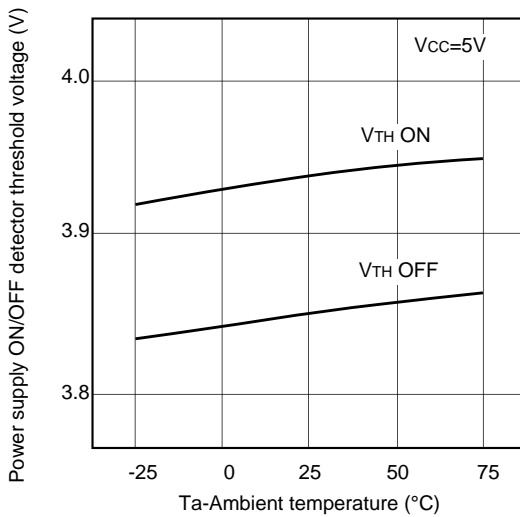
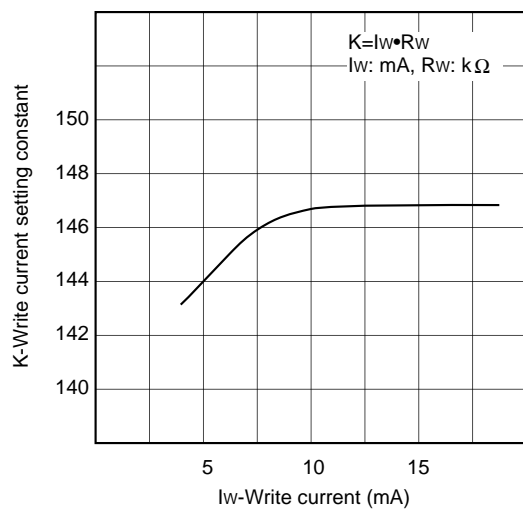
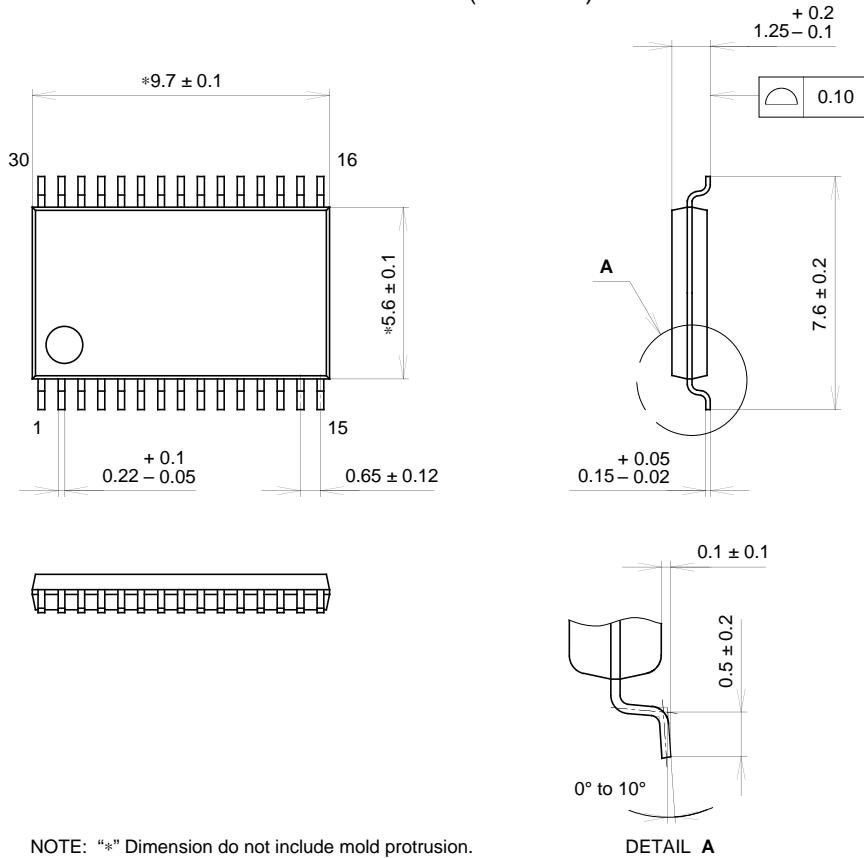

Fig. 12 Write current setting constant K vs. Write current



Package Outline Unit : mm

30PIN SSOP (PLASTIC)



NOTE: "*" Dimension do not include mold protrusion.

DETAIL A

PACKAGE STRUCTURE

SONY CODE	SSOP-30P-L01
EIAJ CODE	SSOP030-P-0056
JEDEC CODE	_____

PACKAGE MATERIAL	EPOXY RESIN
LEAD TREATMENT	SOLDER/PALLADIUM PLATING
LEAD MATERIAL	COPPER/42 ALLOY
PACKAGE WEIGHT	0.1g



LittleDiode supplies new, hard to find or obsolete electronic components and semiconductors all over the world.

With over two million different components listed you are sure to find the part you need.

Feel free to visit us today at our online store:

LittleDiode.com

Looking forward to providing you with the best possible service.