

RGB Decoder/Driver

Description

The CXA1785AR is an RGB decoder/driver designed to drive LCD panels. This IC converts composite video signals, Y/C signals and Y/color difference signals into RGB signals used for driving LCDs.

Features

- Both NTSC/PAL compatible
- Supports composite inputs, Y/C inputs and Y/color difference input
- Band pass filter, trap and delay line
- Sharpness function
- γ compensation circuit
- R, B output delay time adjustment circuit
- Polarity reverse circuit

Applications

- Color liquid crystal viewfinders
- Liquid crystal projectors
- Industrial monitors

Structure

Bipolar silicon monolithic IC

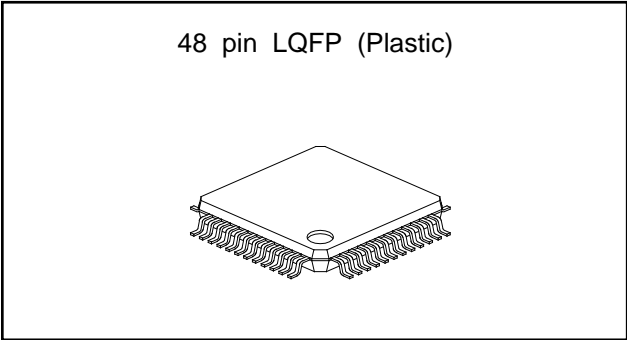

Absolute Maximum Ratings (Ta=25°C)

• Supply voltage	VCC1-GND	6	V
• Supply voltage	VCC2-VEE	15	V
• Supply voltage	GND-VEE	10	V
• Input pin voltage	VIN	VCC1	V
• Operating temperature	Topr	-30 to +85	°C
• Storage temperature	Tstg	-55 to +150	°C
• Allowable power dissipation			
	PD	560	mW

Operating Conditions

• Supply voltage	VCC1-GND	4.25 to 5.25	V
• Supply voltage	VCC2-GND	4.25 to 14.0	V
• Supply voltage	VCC2-VEE	11.25 to 14.0	V
• Supply voltage	VEE-GND	-8.75 to 0	V

Sony reserves the right to change products and specifications without prior notice. This information does not convey any license by any implication or otherwise under any patents or other right. Application circuits shown, if any, are typical examples illustrating the operation of the devices. Sony cannot assume responsibility for any problems arising out of the use of these circuits.

Block Diagram

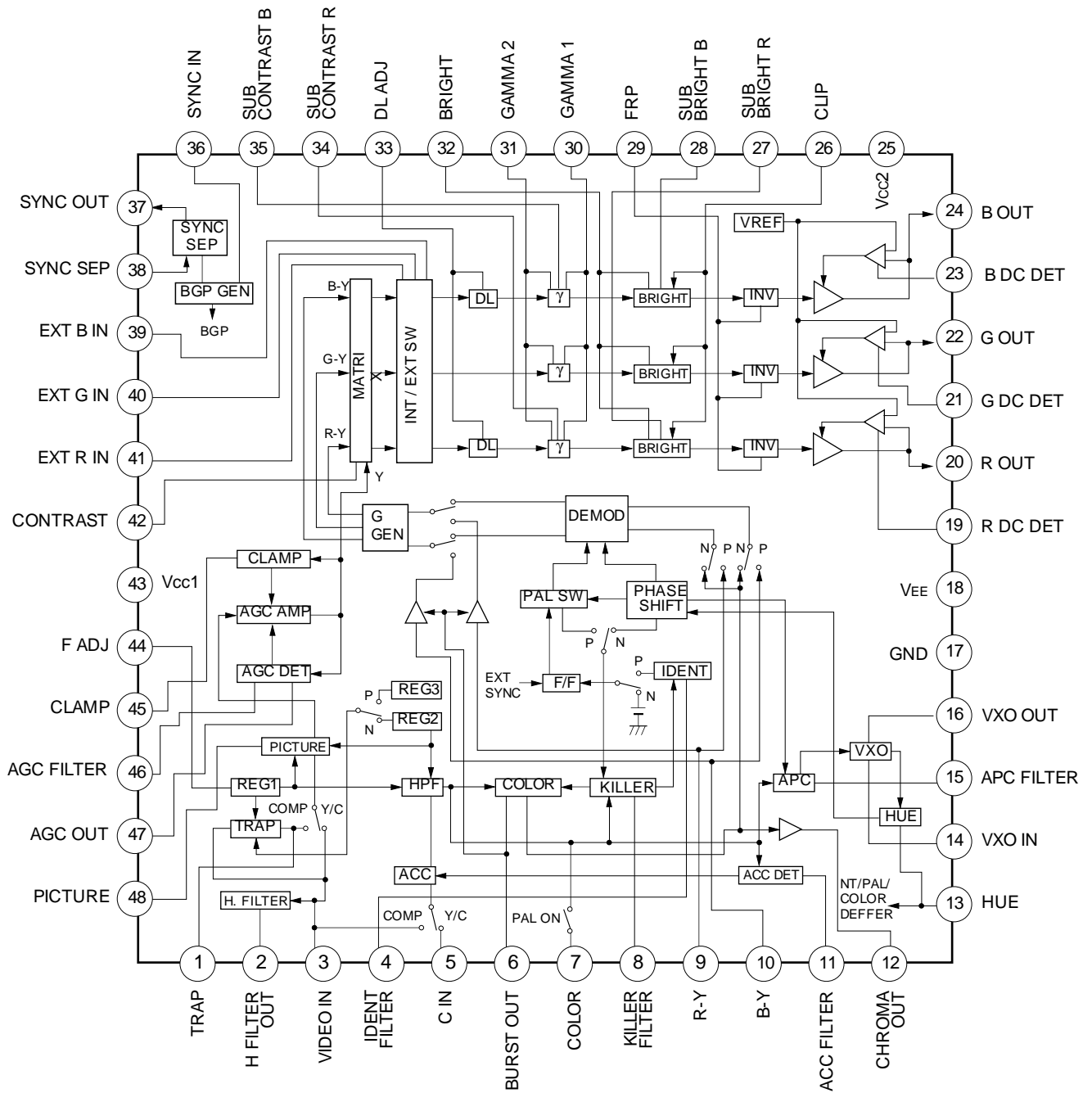

Pin Description

(The pin voltage is $V_{CC1} = 4.5\text{ V}$)

Pin No.	Symbol	Pin voltage	Equivalent circuit	Description
1	TRAP	2.0V		Trap connection. Leave this pin open other than when composite video input is selected.
2	H FILTER OUT			Outputs the video signal to be input to the sync separation circuit.
3	VIDEO IN	2.25V		Composite video signal input (Y signal when using Y/C input and Y/color difference input). The standard input level is 0.5 VP-P (from sync tip to 100 % white).
4	IDENT FILTER			IDENT detection filter connection. Leave this pin open other than when PAL mode is selected.
5	C IN	2.5V		Chroma signal input when using Y/C input. Composite video signal input is supported when this pin is connected to GND. Leave this pin open when Y/color difference input. The standard input level is 0.15 VP-P (burst).

Pin No.	Symbol	Pin voltage	Equivalent circuit	Description
6	COLOR			Color adjustment. The amplitude of color difference signal is adjusted when Y/color difference input.
7	BURST OUT	3.2V		Burst cleaning coil is connected for PAL. Leave this pin open other than when PAL mode is selected.
8	KILLER FILTER			Killer detection filter is connected. Leave this pin open other than when Y/color difference input is selected.
9	R-Y	1.9V		Color difference demodulation circuit inputs. Leave this pin open for NTSC. Color difference signal is input when Y/color difference input. In this case, input is pedestal clamped by using external coupling capacitor.
10	B-Y	1.9V		
11	ACC FILTER			ACC detection filter is connected. Leave this pin open for Y/color difference input.

Pin No.	Symbol	Pin voltage	Equivalent circuit	Description
12	CHROMA OUT	2.3V		Color adjusted and burst taken out chroma signal is output.
13	HUE			Color phase adjustment pin. Also doubles as the NTSC, PAL or Y/color difference switch. PAL is selected when this pin is connected to GND; Y/color difference is selected when this pin is connected to Vcc1.
14	VXO IN	3.9V		VXO input. Leave this pin open for Y/color difference input.
15	APC FILTER			APC detection filter connection. Leave this pin open for Y/color difference input.
16	VXO OUT	2.7V		VXO output. Leave this pin open for Y/color difference input.
17	GND			Ground.
18	VEE			Minimum electric potential connection.

Pin No.	Symbol	Pin voltage	Equivalent circuit	Description
19	R DC DET			Smoothing capacitor connection for the feedback circuit of RGB output DC level control. Use a low-leakage capacitor because this pin has high impedance.
21	G DC DET			
23	B DC DET			
20	R OUT	$\frac{V_{cc2}+V_{EE}}{2}$		RGB primary color signal output.
22	G OUT			
24	B OUT			
25	Vcc2			Power supply connection for RGB output.
26	CLIP	2.3V		Sets the RGB output amplitude (black-black) clip level. This pin is preset internally.
27	SUB BRIGHT R	2.2V		Fine adjustment for R and B signal brightness. Functions with the γ compensation curve. This pin is preset internally.
28	SUB BRIGHT B	2.2V		
29	FRP			Polarity reverse timing pulse input for RGB output. Reversed when low; non-reversed when high.

Pin No.	Symbol	Pin voltage	Equivalent circuit	Description
30	GAMMA1			<p>Adjusts voltage gain change point γ_1.</p>
31	GAMMA2	2.25V		<p>Adjusts voltage gain change point γ_2 and the peak limiter that operates by $V_w \gamma_2$ above γ_2. This pin is preset internally.</p>
32	BRIGHT			<p>RGB output brightness adjustment. Does not function with the gamma compensation curve.</p>
33	DL ADJ	1.2V		<p>Adjusts delay time of R and B output for G output. The delay time is adjusted by changing the resistance value between this pin and GND. The B output delay time is twice the R output delay time. Connecting this pin to Vcc turns off the R output and B output delay circuits.</p>
34	SUB CONTRAST R	2.25V		<p>Fine adjustment for R and B signal contrast. This pin is preset internally.</p>
35	SUB CONTRAST B	2.25V		

Pin No.	Symbol	Pin voltage	Equivalent circuit	Description
36	SYNC IN			High level input when synchronized; low level at all other times. The rising edge of the input pulse must precede the falling edge of the SYNC OUT pulse. For PAL, the internal flip flop switches at the rising edge of the input pulse.
37	SYNC OUT			Outputs the sync signal separated by the sync separation circuit. High level when synchronized and at low level in all other cases. This pin is of an open collector output. The high level for the output should be VEE + 15 V or less.
38	SYNC SEP	1.8V		Sync separation circuit input. Input the H FILTER output signal.
39	EXT B IN			External digital signal input. There are two threshold values: VTH1 (approximately 1.2 V) and VTH2 (approximately 2.2 V). When one of the RGB signals exceeds VTH1, all of the RGB outputs go to black level; when an input exceeds VTH2, only the corresponding output goes to white level.
40	EXT G IN			
41	EXT R IN			
42	CONTRAST			Adjusts RGB output contrast.

Pin No.	Symbol	Pin voltage	Equivalent circuit	Description
43	Vcc1			Power supply connection.
44	F ADJ	1.2V		<p>Connect a resistance between this pin and GND; the outflow current value adjusts the internal filters. Connect 18 kΩ for both NTSC and PAL.</p> <p>The following conditions apply to the resistance connected:</p> <p>Allowable difference in resistance: ±2 %</p> <p>Temperature characteristics: ±200 ppm</p>
45	CLAMP			<p>Clamps the luminance signal pedestal level.</p> <p>Use a low-leakage capacitor because this pin has high impedance.</p>
46	AGC FILTER			Connects AGC detection filter of luminance signal.
47	AGC OUT			<p>Outputs the voltage detected by the AGC detection circuit of luminance signal.</p> <p>When the AGC amplifier gain is high, the output voltage is high.</p>
48	PICTURE			Adjusts frequency response of luminance signal. Decreasing the voltage emphasizes contours.

Electrical Characteristics

AC Characteristics

Unless otherwise specified, VCC1 = 4.5 V, VCC2 = 12 V, VEE = GND, Ta = 25°C, SW5→a, SW8→a, SW9→b, SW10→b, SW12A→a, SW12B→ON, SW13→b, SW20→OFF, SW22→OFF, SW24→OFF SW26→OFF, SW27→OFF, SW28→OFF, SW31→OFF, SW33→b, SW34→OFF, SW35→OFF, SW38→a, SW46→OFF. V5 = 0 V, V6 = 2.6 V, V13 = 2.7 V, V30 = 3.5 V, V32 = 2.1 V, V42 = 2.25 V, V46 = 1.5 V, V48 = 2.5 V, and VR1=6.8 kΩ (C): input SG11, (D): input SG7b (4.5 VP-P)

Note) Adjust the burst cleaning coil so that the amplitude of the color difference signal is the same at each 1H of TP20 when SG5 (4.43 MHz, burst/chroma phase = ±135°) is input to (B) with a standard sample.

Item	Symbol	Conditions	Min.	Typ.	Max.	Unit
Video Block						
Video maximum gain	Gmax	V42 = 1.2 V, input SG8 (-15 dB) to (A). Measure the ratio between the output amplitude (white-black) and input amplitude at TP22.	33	36	39	dB
Amount of contrast adjustment gain variation (1)	Gct1	Input SG8 (-14 dB) to (A). V1, V0, and V2 are the output amplitude (white-black) at TP22 when V42 is changed to 1.2 V, 2.25 V and 3.3 V. Gct1 = 20log (V1/V0) Gct2 = 20log (V2/V0)	3.0	5.5		
Amount of contrast adjustment gain variation (2)	Gct2		- 15	- 11		
AGC amplitude characteristics	Va1	Input SG1 (0 dB) to (A) and adjust V42 so that TP22 output amplitude (white-black) is 4 V when APL = 50 % Va1 and Va2 are the amplitude at TP22 when APL = 10 % and 90 %.	4.6	5.6	6.6	VP-P
	Va2		2.0	2.5	3.0	
AGC detection output	Vad1	Input SG1 (0 dB) to (A). Vad1, Vad2, and Vad3 are the voltage at TP47 when APL = 10 %, 50 %, and 90 %.	2.7	3.0	3.4	V
	Vad2		1.1	1.7	2.3	
	Vad3		0.1	0.5	0.9	
Amount of image quality adjustment variation (composite video input, NTSC)	Gp1	SW5→b, SW46→ON Input SG2 (100 kHz) to (A) and adjust V42 so that the amplitude of the sine wave at TP22 is 0.5 VP-P. Gp1 and Gp2 are the amount of change in the output amplitude at TP22 when SG2 is 2.1 MHz and V48 = 2 V and 3 V.	6.0	9.0		dB
	Gp2			- 4.0	- 1.0	
Amount of image quality adjustment variation (composite video input, PAL)	Gp3	SW5→b, SW13→a, SW46→ON Input SG2 (100 kHz) to (A) and adjust V42 so that the amplitude of the sine wave at TP22 is 0.5 VP-P. Gp3 and Gp4 are the amount of change in the output amplitude at TP22 when SG2 is 2.4 MHz and V48 = 2 V and 3 V.	6.0	9.0		
	Gp4			- 4.0	- 1.0	

Item	Symbol	Conditions	Min.	Typ.	Max.	Unit
Amount of image quality adjustment variation (Y/C input, Y/color difference input)	Gp5	SW5→a, SW46→ON Input SG2 (100 kHz) to (A) and adjust V42	14.0	17.0		dB
	Gp6	so that the amplitude of the sine wave at TP22 is 0.5 V _{P-P} . With SG2 at 1.8 MHz, Gp5 and Gp6 are the amount of change in the output amplitude at TP22 when V48 = 2 V and 3 V.		1.0	3.0	
Trap attenuation (NTSC)	Gtf (NT)	Input SG3 (100 kHz/3.58 MHz, 0 dB) to (A) and measure the output level at TP1 for 3.58 MHz to 100 kHz.		- 45	- 30	
Trap attenuation (PAL)	Gtf (PAL)	SW13→a Input SG3 (100 kHz/4.43 MHz, 0 dB) to (A) and measure the output level at TP1 for 4.43 MHz to 100 kHz.		- 45	- 30	
DC regeneration ratio	K	Input SG1 (APL = 10%, 0 dB) to (A). V1 is the output amplitude (black-black) at TP22. Next, input SG1 (APL = 90%, 0 dB). V2 is the output amplitude (black-black) at TP22. $K = (V1 - V1 - V2) \times 100/V1$	95			%
Chroma Block						
Maximum chroma output (composite video input PAL)	Vcmax1	SW5→b, SW13→a, V6=3.5 V Input SG5 (4.43 MHz, burst/chroma phase = ±135°) to (A) and measure the amplitude of the chroma signal at TP12.	0.7	0.85	1.2	V _{P-P}
Maximum chroma output (Y/C input PAL)	Vcmax2	SW13→a, V6=3.5 V Input SG5 (4.43 MHz, burst/chroma phase = ±135°) to (B) and measure the amplitude of the chroma signal at TP12.	0.7	0.85	1.2	
ACC characteristics (composite video input NTSC)	GA1	SW5→b Input SG5 (0 dB, +6 dB, -25 dB), (burst/chroma phase = 180°) to (A). Measure the output amplitude at TP12, labeling the output corresponding to 0 dB, +6 dB and -25 dB as V0, V1 and V2, respectively. $GA1 = 20\log(V1/V0)$ $GA2 = 20\log(V2/V0)$		0	2.0	dB
	GA2		- 10.0	- 5.0		
ACC characteristics (Y/C input NTSC)	GA3	SW5→a Input SG5 (0 dB, +6 dB, -25 dB), (burst/chroma phase = 180°) to (B). Measure the output amplitude at TP12, labeling the output corresponding to 0 dB, +6 dB and -25 dB as V0, V1 and V2, respectively. $GA3 = 20\log(V1/V0)$ $GA4 = 20\log(V2/V0)$		0	2.0	dB
	GA4		- 9.0	- 4.0		

Item	Symbol	Conditions	Min.	Typ.	Max.	Unit
ACC characteristics (composite video input PAL)	GA5	SW5→b, SW13→a Input SG5 (0 dB, +6 dB, -25 dB), (burst/ chroma phase = ±135°) to (A). Measure the output amplitude at TP12, labeling the output corresponding to 0 dB, +6 dB and -25 dB as V0, V1 and V2, respectively. GA5 = 20log(V1/V0) GA6 = 20log(V2/V0)		0	2.0	
	GA6		- 10.0	- 5.0		
ACC characteristics (Y/C input PAL)	GA7	SW13→a Input SG5 (0 dB, +6 dB, -25 dB), (burst/ chroma phase = ±135°) to (B). Measure the output amplitude at TP12, labeling the output corresponding to 0 dB, +6 dB and -25 dB as V0, V1 and V2, respectively. GA7 = 20log(V1/V0) GA8 = 20log(V2/V0)		0	2.0	
	GA8		- 9.0	- 4.0		
Amount of color adjust- ment gain variation	GC1	Input SG5 (0 dB, burst/chroma phase = 180°) to (B). Measure the chroma signal amplitude at TP12 when V6 = 1.6 V, 2.6 V and 3.5 V, labeling the corresponding output as V0, V1 and V2, respectively. GC1 = 20log(V1/V0) GC2 = 20log(V2/V0)		- 30	- 20	dB
	GC2		4.0	6.0		
HPF characteristics (composite video input)	GHP1	SW5→b Input SG6 (4.43 MHz, 2.5 MHz, 3.58 MHz) to (A), labeling the output amplitude at TP12 corresponding to each frequency as V0, V1 and V2, respectively. GHP1 = 20log(V1/V0) GHP2 = 20log(V2/V0)		- 30	- 10	
	GHP2		- 6.0	- 2.0	1.0	
HPF characteristics (Y/C input)	GHP3	SW5→a Input SG6 (4.43 MHz, 2.5 MHz, 3.58 MHz) to (B), labeling the output amplitude at TP12 corresponding to each frequency as V0, V1 and V2, respectively. GHP3 = 20log(V1/V0) GHP4 = 20log(V2/V0)		- 30	- 10	
	GHP4		- 6.0	- 2.0	1.0	
APC pull-in range (NTSC)	fa1	Input SG5 (0 dB) to (B). Measure the difference between 3.579545 MHz and the input frequency at which the voltage at TP8 is 2 V or less by changing the burst frequency.	±500	+2000 -1000		Hz
APC pull-in range (PAL)	fa2	SW13→a Input SG5 (0 dB) to (B). Measure the difference between 4.433619 MHz and the input frequency at which the voltage at TP8 is 2 V or less by changing the burst frequency.	±500	±1200		

Item	Symbol	Conditions	Min.	Typ.	Max.	Unit
Killer operation input level (NTSC)	Vbk1	Input SG5 (burst/chroma phase = 180°) to (B) and monitor the output at TP12. Gradually reduce the input amplitude and measure the input level at which the killer operation is activated.		- 42	- 37	dB
Killer operation input level (PAL)	Vbk2	SW13→a Input SG5 (burst/chroma phase = ±135°) to (B) and monitor the output at TP12. Gradually reduce the input amplitude and measure the input level at which the killer operation is activated.		- 37	- 32	
Killer color residue (NTSC)	Vbs1	SW8→b, V42=2.6V Input SG5 (burst/chroma phase = 180°) to (B). Measure the amplitude of the color difference output at TP24.		50	100	mVP-P
Killer color residue (PAL)	Vbs2	SW8→b, SW13→a, SW12A→b, V42=2.6V Input SG5 (burst/chroma phase = ± 135°) to (B). Measure the amplitude of the color difference output at TP24.		90	180	
Demodulation output amplitude ratio (NTSC)	R-Y/ B-Y	Input SG5 (0 dB) to (B) and change the chroma phase.	0.56	0.66	0.76	
	G-Y/ B-Y	VR: Maximum output amplitude at TP20 VG: Maximum output amplitude at TP22 VB: Maximum output amplitude at TP24 (R-Y)/(B-Y) = VR/VB (G-Y)/(B-Y) = VG/VB	0.29	0.36	0.44	
Demodulation output amplitude ratio (PAL)	R-Y/ B-Y	SW12A→b, SW13→a, V6 = 2 V Input SG5 (0 dB) to (B) and change the chroma phase.	0.60	0.70	0.84	
	G-Y/ B-Y	VR: Maximum output amplitude at TP20 VG: Maximum output amplitude at TP22 VB: Maximum output amplitude at TP24 (R-Y)/(B-Y) = VR/VB (G-Y)/(B-Y) = VG/VB	0.30	0.38	0.46	
Demodulation relative phase (NTSC)	θRB	Input SG5 (0 dB) to (B) and change the chroma phase.	80	90	100	deg
	θGB	θR: Phase in which output amplitude at TP20 reaches a maximum θG: Phase in which output amplitude at TP22 reaches a maximum θB: Phase in which output amplitude at TP24 reaches a maximum θRB = θR - θB θGB = θG - θB	230	240	250	

Item	Symbol	Conditions	Min.	Typ.	Max.	Unit
Demodulation relative phase (PAL)	θ_{RB}	SW12A→b, SW13→a Input SG5 (0 dB) to (B) and change the chroma phase.	80	90	100	deg
	θ_{GB}	θ_R : Phase in which output amplitude at TP20 reaches a maximum θ_G : Phase in which output amplitude at TP22 reaches a maximum θ_B : Phase in which output amplitude at TP24 reaches a maximum $\theta_{RB} = \theta_R - \theta_B$ $\theta_{GB} = \theta_G - \theta_B$	230	240	254	
Demodulation output residual carrier (NTSC)	VCAR (N)	(C) = OPEN Input SG5 (0 dB) to (B). With V42 = 3.0 V, adjust the chroma phase so that the amplitude at TP24 is at a maximum. Using a spectrum analyzer, measure the 7.15909 MHz component versus the 15.734 kHz component of the output at TP24.		- 40	- 30	dB
Demodulation output residual carrier (PAL)	VCAR (P)	SW12A = b, SW13→a, (C) = OPEN Input SG5 (0 dB) to (B). With V42 = 3.0 V, adjust the chroma phase so that the amplitude at TP24 is at a maximum. Using a spectrum analyzer, measure the 8.867238 MHz component versus the 15.625 kHz component of the output at TP24.		- 50	- 40	
HUE variable range	θ_+	Input SG5 (0 dB) to (B). Label the phase at which the output amplitude at TP24 reaches a maximum when V13 = 1.8 V as θ_1 , when V13 = 2.7 V as θ_2 , and when V13 = 3.6 V as θ_3 .	30	40		deg
	θ_-	$\theta_+ = \theta_1 - \theta_2$, $\theta_- = \theta_3 - \theta_2$	- 30	- 40		
Composite→YC input switching voltage	VthCY	SW5→b Input SG5 (0 dB) to (A) and gradually increase the voltage V5. Measure the voltage at which the output at TP12 disappears.	1.2	1.4	1.6	V
YC→Composite input switching voltage	VthYC	SW5→b Input SG5 (0 dB) to (A) and gradually lower the voltage V5. Measure the voltage at which the output at TP12 appears.	0.7	0.9	1.1	
NTSC↔PAL switching voltage	VthNP	Input SG5 (0 dB, 3.579545 MHz, burst/ chroma phase = 180°) to (B) and gradually lower the voltage V13. Measure the voltage of V13 at which the output at TP24 ceases.	0.4	0.7	1.0	

Item	Symbol	Conditions	Min.	Typ.	Max.	Unit
Color difference input - output maximum gain	Gmax (CD)	SW13→c, SW9→a, SW10→a, V6=3.5V, V42=1.2V, (A)(B) no input. Input SG12 (40 mV amplitude) to (I) and (J). Measure the amplitude at TP20 and TP24.	44	47	50	dB
Color difference input - output gain variation	ΔG(CD)	SW13→c, SW9→a, SW10→a, (A)(B) no input. Input SG12 (40 mV amplitude) to (I) and (J). Measure the output amplitude variation at TP20 and TP24 during V6 = 1.6 V versus V6 = 3.5 V.		- 45	- 30	
NTSC↔Y/color difference switching voltage	VthNCD	SW13→b, SW9→a, SW10→a, V6 = 2.6 V, (A)(B) no input. Input SG12 (0.1 V amplitude) to (I) and (J) and gradually increase the voltage V13. Measure the voltage V13 at which the output at TP20 and TP24 starts.	3.7	4.0	4.3	V
Sync Block						
Sync separation input sensitivity current	Iis	Using the current from (E), measure the input current at which the signal at TP37 changes from low to high.		21	30	μA
Sync separation output ON voltage	VON	Measure the output voltage at TP37.		0.2	0.5	V
External sync input threshold	Veth	Increase the amplitude at SG7b from 0 V and measure the voltage at which the clamp circuit begins to operate.	1.2	1.5	1.8	
H filter output gain	Ghf	Input SG7a to (A) and measure TP2.	8	10	14	dB
H filter output delay time	tpLH (HF)	Input SG7a to (A) and measure TP2. Rising edge tpLH (HF)	300	500	700	ns
	tpHL (HF)	Falling edge tpHL (HF)	300	500	700	
Sync separation output delay time	tpLH (sy)	SW38→b Input SG7 (amplitude: 0.15 Vp-p) to (A) and measure the output at TP37. Rising edge tpLH (sy)	0.8	1.1	1.8	μs
	tpHL (sy)	Falling edge tpHL (sy)	0.3	0.5	0.9	
Interface Block						
Amount of change in brightness	Vb1	No input for (A) and (B). V32 = 1.8 V Measure the output (black-black) at TP20, TP22, and TP24.	9.0			VP-P
	Vb2	No input for (A) and (B). V32 = 2.8 V Measure the output (black-black) at TP20, TP22, and TP24. (When the phase is different from the case of V32 = 2.1 V, make the value negative.)			1.0	

Item	Symbol	Conditions	Min.	Typ.	Max.	Unit
Amount of change in sub-brightness	Vsb	No input for (A) and (B). V32 = 2.3 V Measure the difference in amplitudes (black-black) at TP20 and TP24 when SW27 and SW28 are off, and when SW27 and SW28 are on, and V27 and V28 are at 1.0 V and 3.0 V.	±1.0	±2.5		V
Amount of change in sub-contrast gain	ΔGsc1	Input SG8 (-14 dB) to (A). Measure the difference in output amplitudes (white-black) at TP20 and TP24 when SW34 and SW35 are off, and when SW34 and SW35 are on, and V34 and V35 are at 1.0 V and 3.0 V. Define them as ΔGsc1 and ΔGsc2, respectively.		- 5.0	- 4.0	dB
	ΔGsc2		2.5	3.5		
RGB output DC voltage	VRGB	No input for (A) and (B). Adjust V32 and measure the DC voltage at TP20, TP22, and TP24 with the amplitude (black-black) at TP22 is 0 V and 9 V _{P-P} .	5.8	6.0	6.2	V
Difference in electric po-tential for inter-RGB output black levels	ΔVBL	No input for (A) and (B). Measure the difference between the maximum and minimum black levels when TP20, TP22, and TP24 are reversed and not reversed, respectively.			300	mV
Difference in reversed/ non-reversed voltage gain	ΔGINV	Input SG8 (-11 dB) to (A). Measure the difference between the non-reversed output amplitude (white-black) and the reversed output amplitude at TP20, TP22 and TP24.		±0.3	±0.6	dB
Difference in inter-RGB gain (with DL OFF)	ΔGRBG	Input SG8 (-11 dB) to (A). Measure the level difference of the maximum and minimum in non-reversed output amplitude (white-black) at TP20, TP22 and TP24.		0.3	0.6	
Difference in inter-RGB gain (with DL ON)	ΔGRBG	SW33→a Input SG8 (-11 dB) to (A). Measure the level difference of the maximum and minimum in non-reversed output amplitude (white-black) at TP20, TP22 and TP24.		0.4	0.7	
FRP input threshold	VthFRP	Input SG8 (-11 dB) to (A). While increasing the voltage at (C), measure the voltage at which the output reverses at TP20, TP22, and TP24.	1.2	1.5	1.8	V

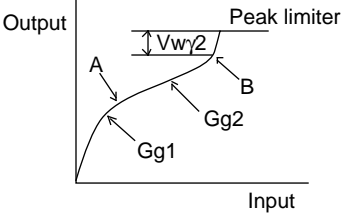
Item	Symbol	Conditions	Min.	Typ.	Max.	Unit
External digital RGB input threshold	VthEXT1	Input SG8 (-11 dB) to (A). Input SG10 to (F), (G), and (H) and increase	1.0	1.2	1.4	V
	VthEXT2	the amplitude starting from 0 V; VthEXT1 is the voltage at which the output goes to black level for the input at TP20, TP22, and TP24 Increase the voltage further; VthEXT2 is the voltage at which the output for that input goes to white level.	2.0	2.2	2.4	
γ compensation characteristics	G γ 1	SW31→ON, SW46→ON, V30 = 2.1 V, V31 = 2.1 V, V42 = 1.2 V (contrast Max.)	33	36	39	dB
	G γ 2	Input SG9 to (A), and measure the gain at TP20, TP22, and TP24.	19	22	25	
	VW γ 2	 <p>VWγ 2 is the difference in electric potential between point B, where the compensation cuts out, and the peak limit point.</p>	0.5	0.7	0.9	V
Delay line R delay time	tDR1	SW33→a, VR1 = 9.1 k Ω , V42 = 2.7 V. Input SG4 to (A). Measure the delay time at TP20 output to TP22 output.	105			ns
	tDR2	SW33→a, VR1 = 4.7 k Ω , V42 = 2.7 V. Input SG4 to (A). Measure the delay time at TP20 output to TP22 output.			45	
Delay line B delay time	tDB1	SW33→a, VR1 = 9.1 k Ω , V42 = 2.7 V. Input SG4 to (A). Measure the delay time at TP24 output to TP22 output.	210			ns
	tDB2	SW33→a, VR1 = 4.7 k Ω , V42 = 2.7 V. Input SG4 to (A). Measure the delay time at TP24 output to TP22 output.			90	
Delay line RB delay ratio	tD(RAT)1	tpHL1tD (RAT)1 = tDR1 / tDB1	0.4	0.5	0.6	
	tD(RAT)2	tD (RAT)2 = tDR2 / tDB2	0.4	0.5	0.6	
Propagation delay time between input and output (composite input)	tpLH1	SW5→b, SW20, SW22, SW24→ON Input SG4 to (A). Adjust V42 and set the amplitude (white - black) at TP20, TP22, and TP24 to 4 V, and measure the rise time tpLH1 and fall time tpHL1.	400	520	700	ns
	tpHL1		400	520	700	
Propagation delay time between input and output (Y/C input)	tpLH2	SW5→a, SW20, SW22, SW24→ON Input SG4 to (A). Adjust V42 and set the amplitude (white - black) at TP20, TP22, and TP24 to 4 V, and measure the rise time tpLH2 and fall time tpHL2.	400	520	700	ns
	tpHL2		400	520	700	

Item	Symbol	Conditions	Min.	Typ.	Max.	Unit
Propagation delay time between input and output (Y/color difference input)	tpLH3	SW13→c, SW20, SW22, SW24→ON SW12B→OFF Input SG4 to (A). Adjust V42 and set the amplitude (white-black) at TP20, TP22, and TP24 to 4V, and measure the rise time tpLH3 and fall time tpHL3.	200	300	400	ns
	tpHL3		200	300	400	
Propagation delay time between EXT and output	tpLH4	SW20, SW22, SW24→ON Input SG10 to (F), (G), and (H). Use V30 to adjust the output amplitude at TP20, TP22, and TP24 to 4.5 V, and measure the rise time tpLH4 and fall time tpHL4.	60	120	180	ns
	tpHL4		140	200	260	
Output rise and fall times for EXT input	tTLH	SW20, SW22, SW24→ON Input SG10 to (F), (G), and (H). Use V30 to adjust the output amplitude at TP20, TP22, and TP24 to 4.5 V, and measure the rise time tTLH and fall time tTHL.	20	50	100	ns
	tTHL		60	100	160	
Frequency response	f1DON	SW5→a, SW20, SW22, SW24→ON, V42=2.6V, V48=1.7V Input SG2 (100kHz) to (A). Increase the frequency of input signal and measure the frequency at SW33 ON/OFF, respectively. The frequency must be measured at 3dB lowered in comparison with when sine wave amplitude is 100kHz.	5.0	6.0		MHz
	f1DOFF		5.0	6.0		
	f2DON	SW5→a, SW20, SW22, SW24→ON, V42=2.6V, V48=3.0V Input SG2 (100kHz) to (A). Increase the frequency of input signal and measure the frequency at SW33 ON/OFF, respectively. The frequency must be measured at 3dB lowered in comparison with when sine wave amplitude is 100kHz.	3.0	4.0		
	f2DOFF		3.0	4.0		
CLIP control range	VCLIP	No input for (A) and (B). V32 = 2.3 V Measure the difference in the output amplitude (black - black) at TP20, TP22, and TP24 when SW26→OFF and when SW26→with V26 = 3.0 V.	3.0	4.0		V

Electrical Characteristics

DC Characteristics

Unless otherwise specified, $V_{CC1} = 4.5\text{ V}$, $V_{CC2} = 12\text{ V}$, $V_{EE} = \text{GND}$, $T_a = 25^\circ\text{C}$, SW5→a, SW8→a, SW9→b, SW10→b, SW12A→a, SW12B→ON (SW12B→OFF for Y/color difference input), SW13→b (SW13→c for Y/color difference input), SW20→OFF, SW22→OFF, SW24→OFF, SW26→OFF, SW27→OFF, SW28→OFF, SW31→OFF, SW33→a, SW34→OFF, SW35→OFF, SW38→a, and SW46→OFF.

$V_6 = 2.6\text{ V}$, $V_{13} = 2.7\text{ V}$, $V_{30} = 3.5\text{ V}$, $V_{32} = 2.1\text{ V}$, $V_{42} = 2.25\text{ V}$, $V_{48} = 2.5\text{ V}$, and $VR1 = 6.8\text{ k}\Omega$

(C): input SG11, (D): input SG7b (4.5 V_{P-P})

No.	Item	Symbol	Conditions	Min.	Typ.	Max.	Unit
1	Current consumption	I _{CC1A}	Measure the inflow current to Pin 43		27.0	35.0	mA
2	Current consumption (for Y/color difference input)	I _{CC1B}	Measure the inflow current to Pin 43		24.0	32.0	
3	Current consumption	I _{CC2}	Measure the inflow current to Pin 25		3.0	4.3	
4	TRAP output impedance	Z ₁			1.0		kΩ
5	VIDEO IN input impedance	Z ₃			12.0		
6	C IN input impedance	Z ₅			3.6		
7	BURST OUT output impedance	Z ₇			2.5		
8	R-Y input impedance	Z ₉	Hi-Z when Y/color difference input		21		
9	B-Y input impedance	Z ₁₀	Hi-Z when Y/color difference input		21		
10	CLIP input impedance	Z ₂₆			53		
11	SUB BRIGHT R input impedance	Z ₂₇			53		
12	SUB BRIGHT B input impedance	Z ₂₈			53		
13	GAMMA2 input impedance	Z ₃₁			53		
14	SUB CONTRAST R input impedance	Z ₃₄			53		
15	SUB CONTRAST B input impedance	Z ₃₅			53		
16	EXT B IN input impedance	Z ₃₉			100		
17	EXT G IN input impedance	Z ₄₀			100		
18	EXT R IN input impedance	Z ₄₁			100		
19	C IN pin current	I ₅	V ₅ =GND		4.0	6.0	μA
20	COLOR pin current	I ₆	V ₆ =3.5V		0.3	1.0	
21	HUE pin current	I ₁₃	V ₁₃ =4.0V		0.2	1.0	
22	HUE pin current	I ₁₃	V ₁₃ =GND	- 1.0	- 0.2		
23	FRP pin current	I ₂₉	V ₂₉ =GND	- 1.0	- 0.2		
24	GAMMA1 pin current	I ₃₀	V ₃₀ =GND	- 6.0	- 2.0		
25	BRIGHT pin current	I ₃₂	V ₃₂ =2.5V		0.2	1.0	
26	SYNC IN pin current	I ₃₆	V ₃₆ =GND	- 1.0	- 0.2		
27	CONTRAST pin current	I ₄₂	V ₄₂ =3.0V		0.2	1.0	
28	PICTURE pin current	I ₄₈	V ₄₈ =3.0V		0.2	1.0	

Input Waveforms

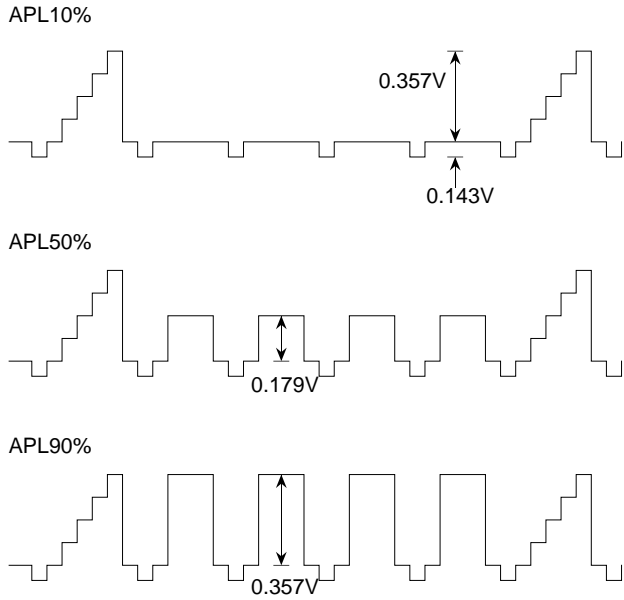
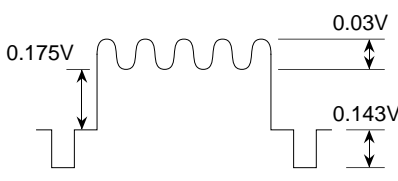
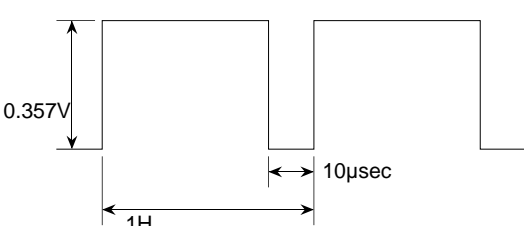
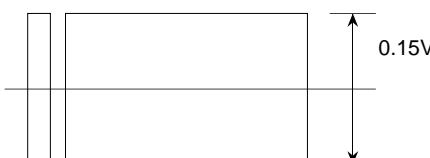
SG NO.	Waveform
SG1	<p>APL variable, 5-step wave</p>  <p>APL10% 0.357V 0.143V</p> <p>APL50% 0.179V</p> <p>APL90% 0.357V</p>
SG2	<p>The sine wave video signal is shown below. Amplitude and frequency are variable.</p>  <p>0.175V 0.03V 0.143V</p>
SG3	<p>Sine wave; amplitude 150 mV_{P-P}, frequency variable</p>
SG4	 <p>0.357V 10µsec 1H</p>
SG5	<p>Chroma signal Burst amplitude 150 mV_{P-P}, chroma amplitude 150 mV_{P-P} Burst, chroma frequency (3.579545 MHz, 4.433619 MHz) Chroma phase variable</p>  <p>0.15V</p>

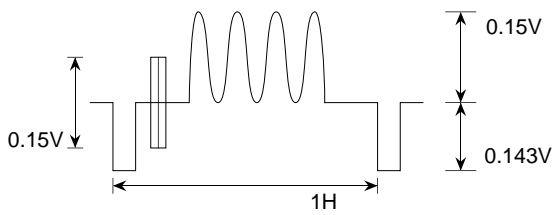
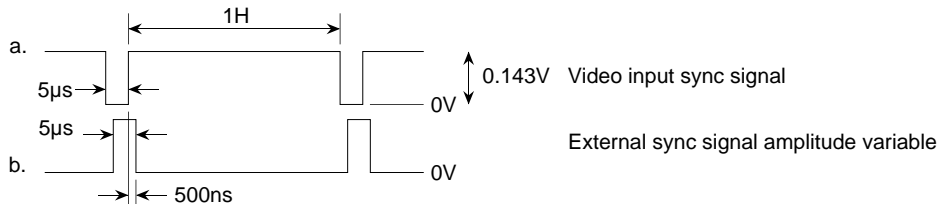
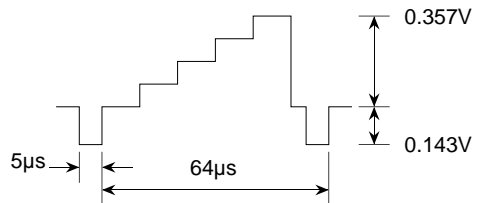
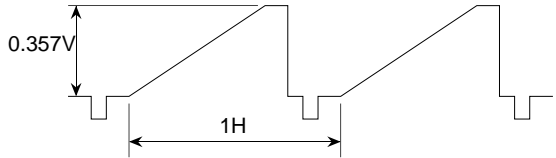
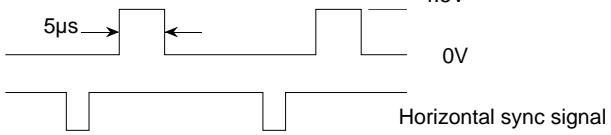
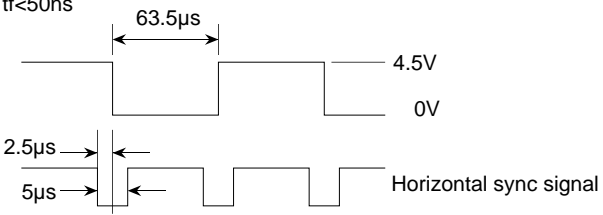
SG NO.	Waveform
SG6	<p>Sine wave video signal, frequency variable.</p> 
SG7	<p>Horizontal sync signal, amplitude variable.</p>  <p>0.143V Video input sync signal</p> <p>External sync signal amplitude variable</p>
SG8	<p>5-step wave. 0 dB is shown below.</p> 
SG9	
SG10	<p>tr, tf < 50ns</p>  <p>4.5V</p> <p>0V</p> <p>Horizontal sync signal</p> <p>Synchronization with the horizontal sync signal</p>
SG11	<p>FRP pulse</p> <p>tr, tf < 50ns</p>  <p>4.5V</p> <p>0V</p> <p>Horizontal sync signal</p>

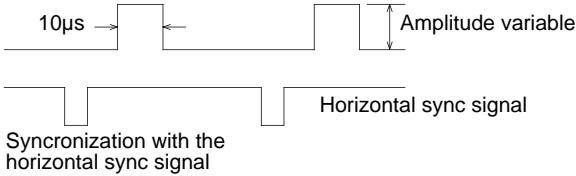
SG NO.	Waveform
SG12	 <p>10µs → ←</p> <p>Amplitude variable</p> <p>Horizontal sync signal</p> <p>Synchronization with the horizontal sync signal</p>

Switching Characteristics

Timing chart

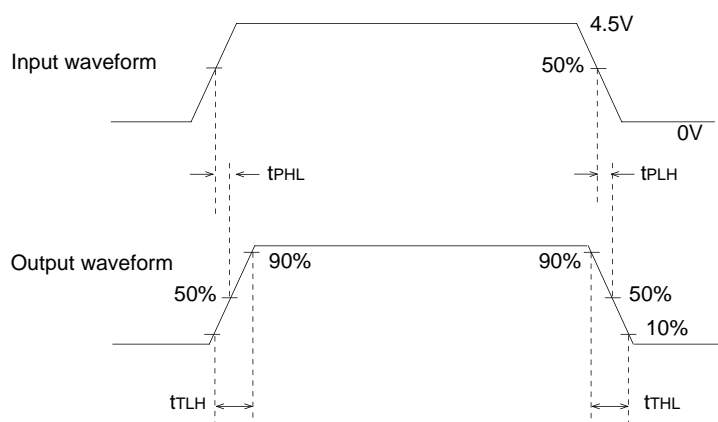

Electrical Characteristics Measurement Circuit

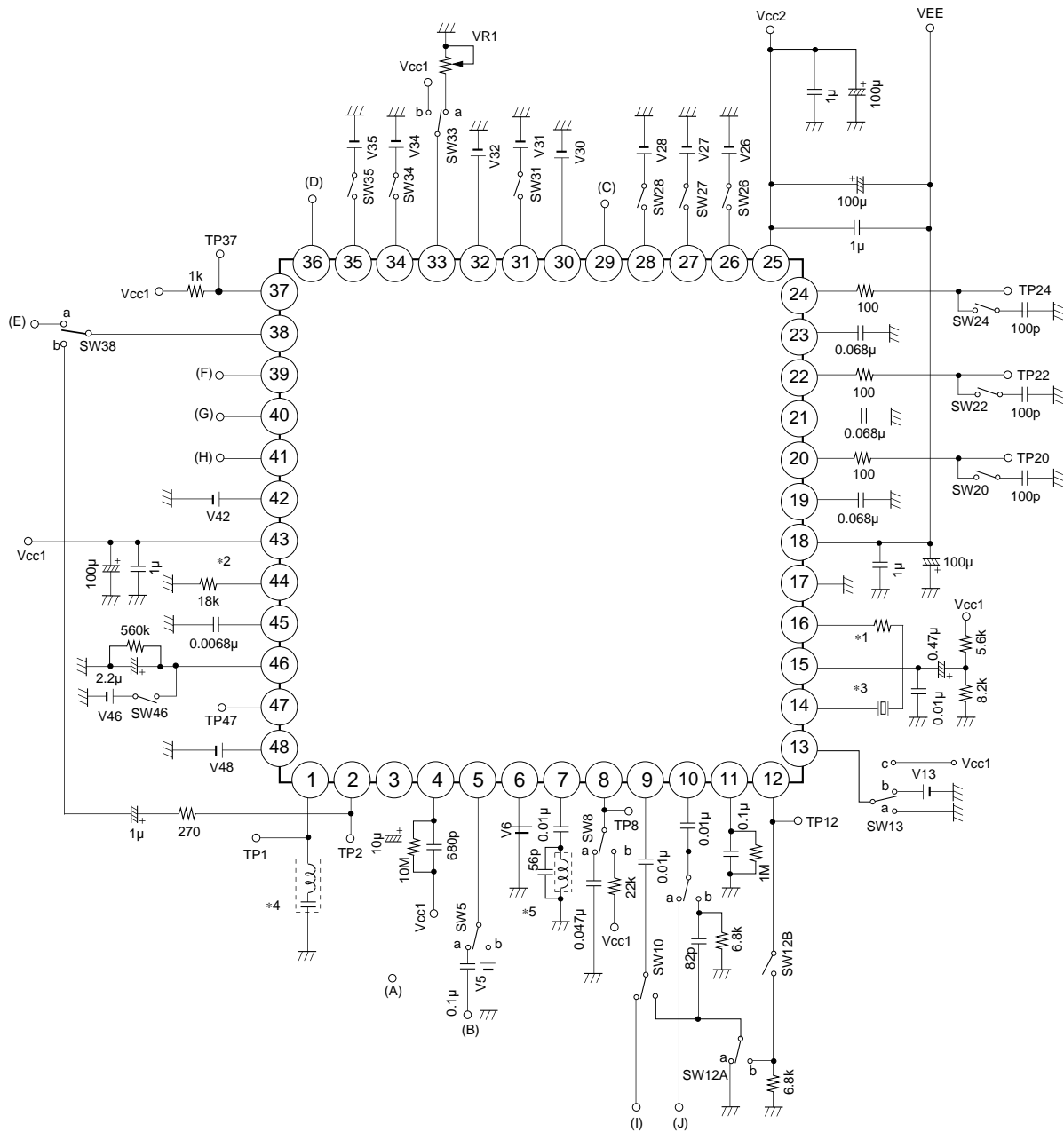

- *1 1 kΩ for NTSC, no resistance for PAL.
- *2 Allowable difference in resistance: ±2 %
Temperature characteristics: ±200 ppm
- *3 KINSEKI CX-5F
Frequency: 3.579545 MHz (NTSC mode)
4.433619 MHz (PAL mode)
Load capacity 16 pF, frequency deviation within ±30 ppm, frequency temperature characteristics within ±30 ppm
- *4 TDK NLT 4532-S3R6B (NTSC mode)
NLT 4532-S4R4 (PAL mode)
- *5 TOKO 332 PN-2636BS

Description of Operation

- Trap

The trap frequency switches between 3.58 MHz for NTSC and 4.43 MHz for PAL.

When using Y/C input and Y/color difference input, the signal does not pass through the trap.

- Video AGC circuit

Different AGC characteristics are obtained, depending on the APL level of the luminance signal.

The gain for the luminance signal is adjusted through peak detection.

- ACC detection, ACC amplifier

The peak amplitude of the ACC amplifier output burst signal is detected, and is used to control the ACC amplifier gain.

- VXO, APC detection

The VXO local oscillation circuit is a Pierce-type crystal oscillation circuit.

The phases of the input burst signal and the VXO oscillator output are compared in the APC detection block, and the detective output is used to form a PLL loop that controls the VXO oscillation frequency, which means that the need for adjustments is eliminated.

- External inputs

Digital input with two thresholds has a pull-down resistor of 100 k Ω . When one of the RGB inputs is higher than the lower threshold VTH1, all RGB outputs go to black level. When the higher threshold VTH2 is exceeded, the output for only the signal in question goes to white level, while the other outputs remain at black level.

- γ compensation

In order to support the characteristics of liquid crystal panels, the I/O characteristics are as shown in Fig. 1.

The characteristics can be changed to those shown in Fig. 2 by adjusting Pin 30, or to those shown in Fig. 3

by adjusting Pin 31. The peak limiter function is linked to point B.

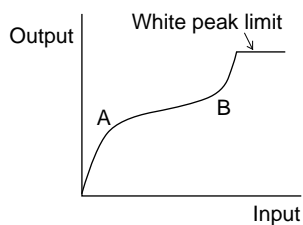

Fig. 1

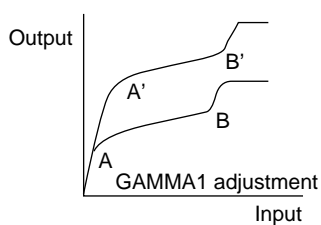

Fig. 2

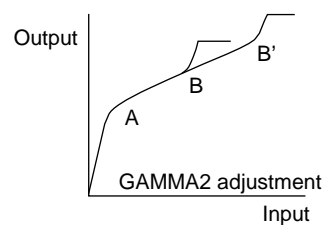
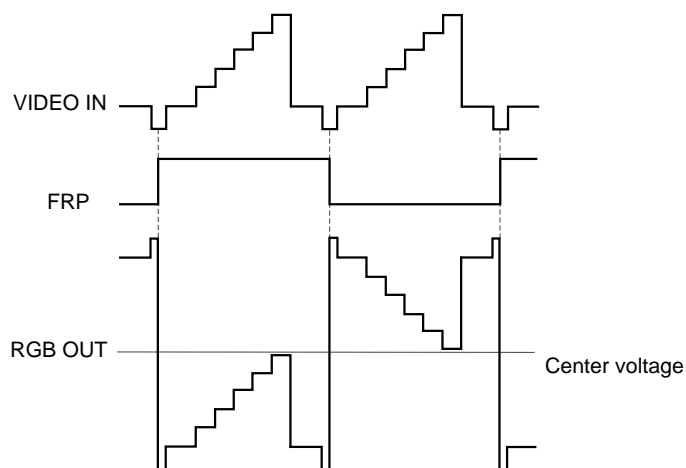

Fig. 3

- RGB output

The primary color signals from the RGB outputs (Pins 20, 22, and 24) are reversed by the FRP pulse input to Pin 29, as shown in Fig. 4. Feedback is applied so that the center voltage of the output signals matches the reference voltage $(V_{CC2} + V_{EE})/2$.



Notes on Operation

- Power supply pins

Always connect the minimum electric potential applied to the IC to Pin 18; do not leave Pin 18 open.

The voltages applied to the supply voltage pins must satisfy the following relationship:

$$V_{EE} \leq GND \leq V_{CC1} \leq V_{CC2}$$

- White balance adjustment

If the SUB BRIGHT (Pins 27 and 28) and the SUB CONTRAST (Pins 34 and 35) are left at their preset states and no white balance adjustment is made in the liquid crystal display system, the white balance may be lost due to slight variations in the electronic components in this system. Therefore, it is recommended that some type of white balance adjustment always be made.

Application Circuit (PAL)

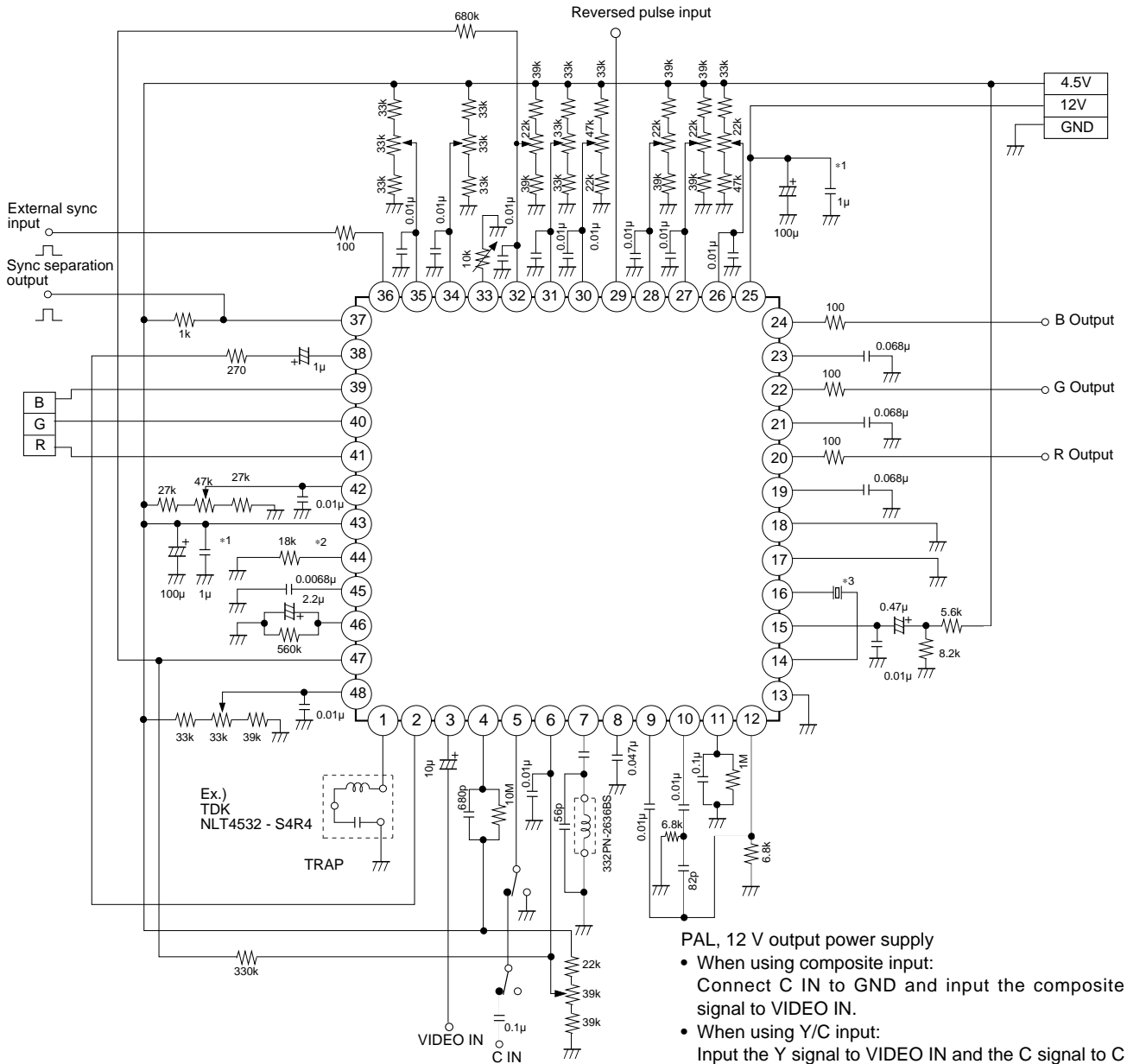

PAL, 12 V output power supply

- When using composite input: Connect C IN to GND and input the composite signal to VIDEO IN.
- When using Y/C input: Input the Y signal to VIDEO IN and the C signal to C IN. In this case, the TRAP for Pin 1 is not needed.

- *1 Use a ceramic capacitor for the decoupling capacitor 1µF for the power supply, and connect it close to the IC pin.
- *2 Allowable difference in resistance: ±2 %
Temperature characteristics: ±200 ppm
- *3 KINSEKI CX-5F
Frequency: 4.433619 MHz
Load capacity 16 pF, frequency deviation within ±30 ppm, frequency temperature characteristics within ±30 ppm

Application circuits shown are typical examples illustrating the operation of the devices. Sony cannot assume responsibility for any problems arising out of the use of these circuits or for any infringement of third party patent and other right due to same.

Application Circuit (Y/color difference input)

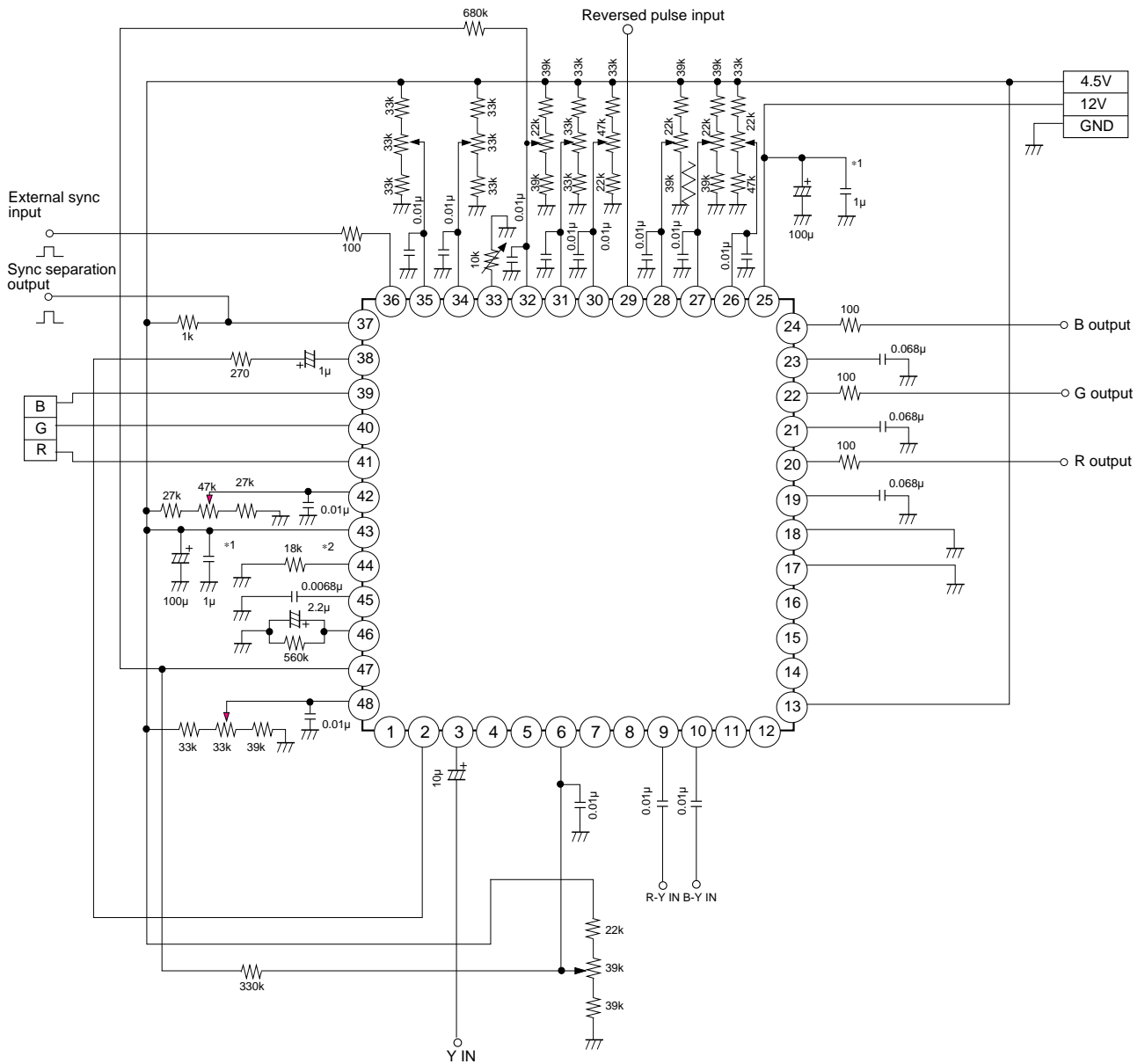

- *1 Use a ceramic capacitor for the decoupling capacitor 1µF for the power supply, and connect it close to the IC pin.
- *2 Allowable difference in resistance: ±2 %
Temperature characteristics: ±200 ppm

Application circuits shown are typical examples illustrating the operation of the devices. Sony cannot assume responsibility for any problems arising out of the use of these circuits or for any infringement of third party patent and other right due to same.

Package Outline Unit : mm

48PIN LQFP (PLASTIC)

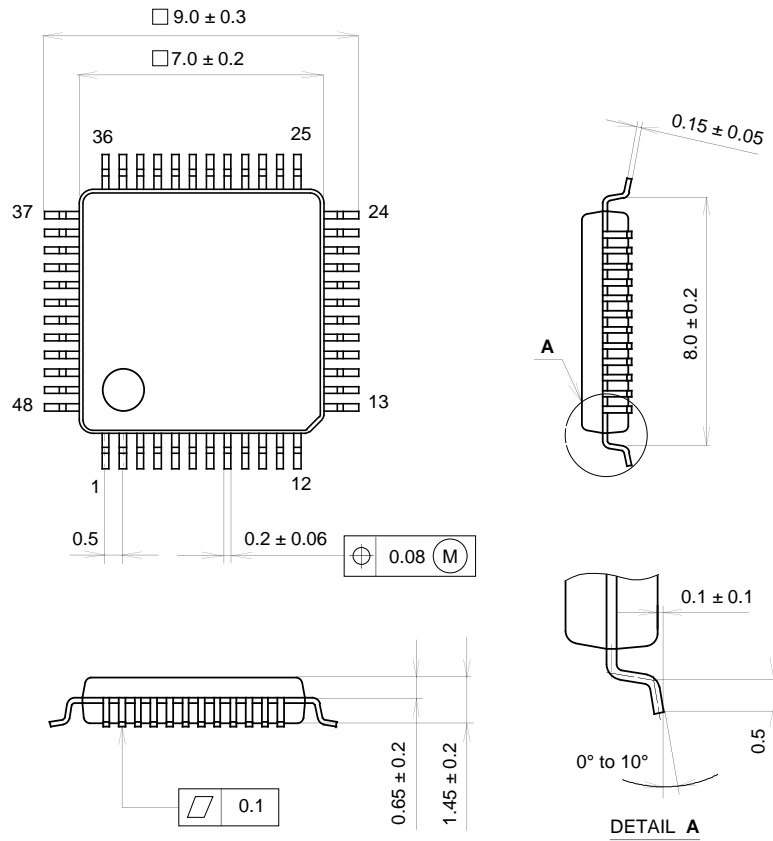

PACKAGE STRUCTURE

SONY CODE	LQFP-48P-L111
EIAJ CODE	LQFP048-P-0707-AP
JEDEC CODE	_____

PACKAGE MATERIAL	EPOXY RESIN
LEAD TREATMENT	SOLDER PLATING
LEAD MATERIAL	42 ALLOY
PACKAGE WEIGHT	0.2g



LittleDiode supplies new, hard to find or obsolete electronic components and semiconductors all over the world.

With over two million different components listed you are sure to find the part you need.

Feel free to visit us today at our online store:

LittleDiode.com

Looking forward to providing you with the best possible service.